

**Bilbao Re-Effect: Container + Contents + Context  
Architectural Strategies for the 21st Century Art Museum**

by

Christopher Paul Friel

Submitted in partial fulfilment of the requirements  
for the degree of Master of Architecture

at

Dalhousie University  
Halifax, Nova Scotia  
March 2016

© Copyright by Christopher Paul Friel, 2016

# CONTENTS

Abstract .....	iv
Acknowledgements .....	v
chapter 1: Introduction .....	1
Thesis Question.....	2
Museum + Art: A synchronous Morphology .....	2
Cabinets of Curiosities.....	4
Enlightenment.....	5
Paradigmatic Shift .....	5
The Boom .....	8
Bilbao Effect.....	10
Bilbao Defect .....	11
Helsinki Competition .....	12
Container + Contents .....	15
Icon.....	15
Container vs Contents .....	15
Research Scope .....	16
Layout Strategies.....	18
Strategic Positioning .....	19
Three Key Distinctions.....	21
Detrimental .....	21
Neutral .....	22
Productive.....	22
Productive Tension .....	23
Ways of Achieving Productive Tension .....	25
chapter 2: container + Contents + Context.....	28
Container + Contents .....	28
Test Case (Art Gallery of Nova Scotia).....	28
Context .....	30
Region .....	30
City.....	32

Locating Site .....	36
Design Investigation .....	34
City as Container .....	34
Waterfront Evolution .....	44
CHAPTER 3: Design .....	48
Site Strategies .....	48
Lighting Strategies .....	50
Design Sequence .....	52
Site context .....	52
Site Parameters .....	52
Contemporary Harbourfront Building Typology.....	53
Historical Connection to the Harbour.....	53
Re-establishing the Historical Harbourfront.....	54
Lifting the Building .....	54
Elevating the Art.....	55
Extending the Boardwalk .....	55
City Gallery .....	56
Merging the Boardwalk with Building Circulation.....	56
Introduction of the Service Core .....	57
Facade Elements.....	57
Situating the AGNS.....	58
Program.....	59
Achieving Productive Tension .....	61
CHAPTER 4: Conclusion.....	84
Appendix:.....	85
BIBLIOGRAPHY .....	94

## **ABSTRACT**

Throughout the history of art museums and galleries, the container, its contents, and the surrounding context, have retained a tuneful relationship; yet, in 20th century we witness a major shift, with the container taking centre stage, often to the detriment of the art and community. This thesis looks at this historical transformation, as a way to understand today's polarizing container vs contents debate and embarks on an in-depth analysis of case studies throughout the western hemisphere, culminating into an architectural strategy, in pursuance of a 'productive tension' between Container + Contents + Context. The architectural proposal for this thesis is a new building for the Art Gallery of Nova Scotia, situated on the Halifax waterfront—the precise site of first settlement, and centre of the downtown core.

## **ACKNOWLEDGEMENTS**

For your immeasurable enthusiasm, love and support:  
my family (John, Jeannette, Andrew, Caroline, Emma, Erica, Eric, Melissa, Claire, Emily,  
Leah, Sean, Patrick, Erin, JJ, Cheri, David, Tara, Caitlin and Fred).

For believing in my thesis, keeping me smart, and endowing me with your wisdom:  
Diogo and Susan.

For being the best companion, friend, and colleague I could ever dream of:  
D'Arcy.

For your friendship, insight, support, transparency, openness and investment:  
The Art gallery of Nova Scotia (Sarah and Ray).

For your extraordinary cooperation and passion for the arts:  
the museum staff throughout the United States.

For your conversation and interest:  
the visual arts community.

For inspiring me with your greatness:  
my wonderful friends.

For everything that you do:  
all of the secretarial staff.

Thank you.

## CHAPTER 1: INTRODUCTION

The Guggenheim Museum in Bilbao, Spain, designed by Frank Gehry, opened its doors on October 19, 1997. In its first year, the museum attracted 1.36 million visitors, 79% of whom came for the sole purpose of viewing the architecture.<sup>1</sup> As part of a larger economic development plan for a declining city, the museum earned unprecedented success, demonstrating what a single building can do for a city and its surrounding region. The Guggenheim Bilbao initiated a surge in museum construction in cities around the globe, all in pursuit of their own cultural and economic rebirth, spawning the 'Bilbao Effect'.

Now competing with other forms of entertainment, these new art museums enjoy record numbers of visitors earning their place as primary tourist destinations and elemental regional economic drivers. In a positive light, these new institutions have systematically dismantled the highbrow stigma historically associated with the museum, and are now positioned in the mainstream; on the other hand, these cities' overarching desire for an icon, in tandem with an architect's desire for their own art object, often produces a result in direct competition with the work that it contains, concluding in a container deemed more important than its contents.

A polarizing view maintained by many artists and curators places the cultural artifacts, collections and exhibits at the forefront of the museum agenda. From their perspective, in order to ensure the maximum amount of flexibility, the architecture should be complementary to the art, often culminating in the desire for 'neutral' spaces. In an effort to understand the complexities of the two conflicting arguments, prioritizing either the container or the contents, I travelled across the United States, The UK and France, visiting seminal art museums designed by notable architects. The thesis was initially guided by several questions: What is architecture for art? Is there potential for the container and the contents to be in constructive dialogue? How can an art museum work for the artist, curator and city?

---

1. "Bilbao One Year Anniversary: Unprecedented Success," Guggenheim, last modified November 2, 1998, <http://www.guggenheim.org/new-york/press-room/releases/press-release-archive/1998/722-november-2-bilbao-one-year-anniversary-unprecedented-success>.

## Thesis Question

How might an investigation into the relationship between the container, contents and context, help to cultivate a productive exchange between architecture, art and city?

## MUSEUM + ART: A SYNCHRONOUS MORPHOLOGY

Western Culture's desire to gather, collect and be surrounded with objects is innately human. Beyond the instinctive predilection for collecting, other reasons vary from the desire for knowledge, personal pleasure, competitiveness, altruism, and the desire to control. The museum as we know it today was born out of a blend of these tendencies. While art museum visitors seek varied experiences, what they ultimately take home, is often the unexpected. Churches, Cabinets of curiosities, picture galleries, modern boxes, minimal spaces, and expressive environments—these buildings contain a gamut of objects that have tremendous potential for discovery, often taking visitors on new unforeseen journeys. In its simplest definition, the art museum is defined as a cultural storage house, a home for the collection, preservation, and education of a culture's art objects; additionally, the definition of the art museum is constantly evolving, its shape, derived from its contemporary environment, it reveals a moment in history.



Photograph of The Queen Elizabeth II great Court, British Museum, London, England. Designed by Foster and Partners, the renovation transformed the Museum's inner courtyard.

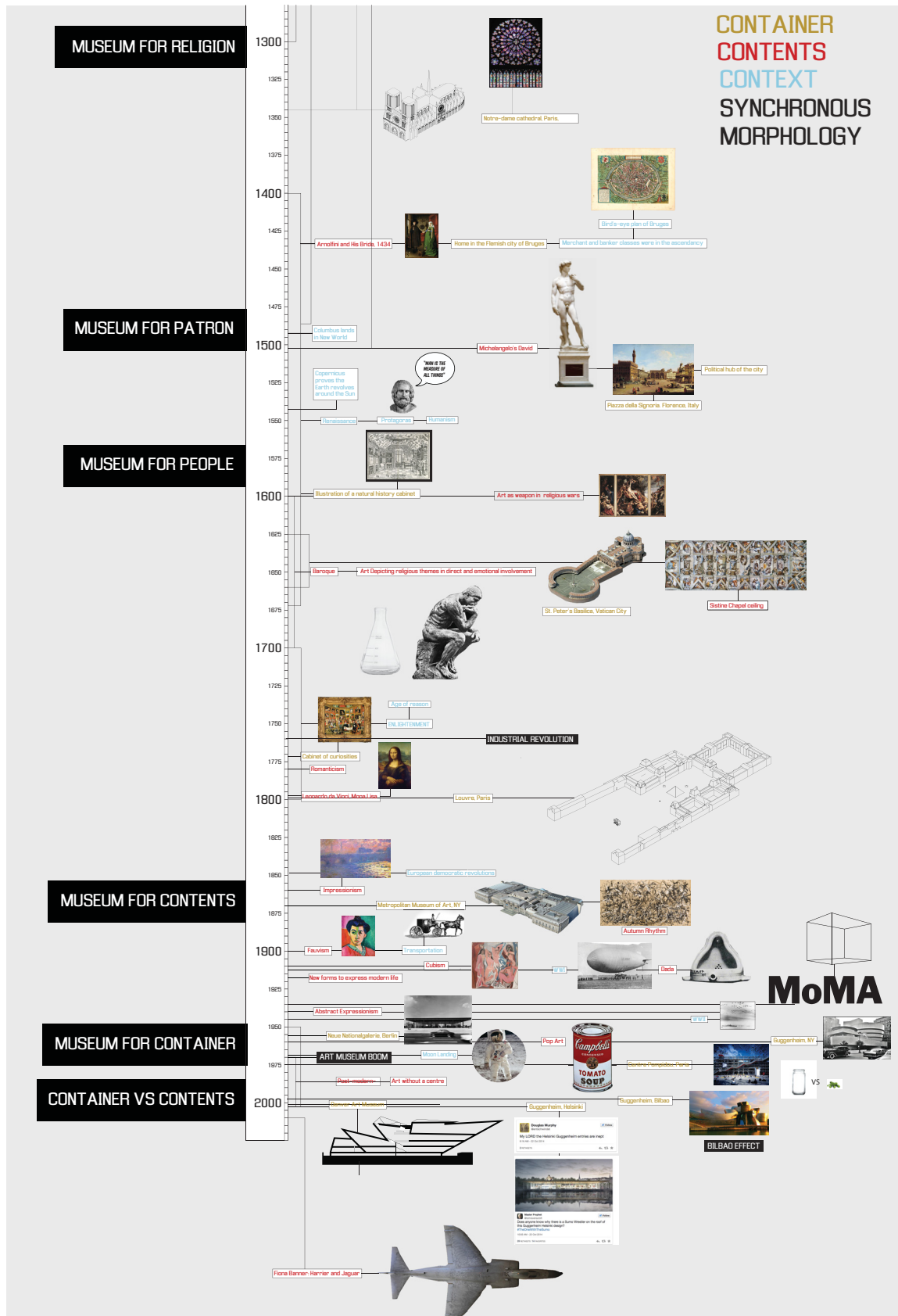

Collage outlining the relationship between container, contents and context, throughout history.



## Cabinets of Curiosities

First documented in the Renaissance, the word “museum” as it is known today, received its debut in fifteenth century Europe to describe the private collection of the well-known patron of the arts, Lorenzo de’ Medici in Florence.<sup>2</sup> For the next two centuries, museum production housed private collections known as ‘Cabinets of Curiosities’. Intended predominantly for the wealthy and aristocratic society, the contents varied from religious, political, mythological and domestic themes, with usual dimensions confined to the domestic scale. The container was typically a large room in private residences, filled top to bottom with extraordinary objects depicting the wonders and curiosities of the world. In spite of their small footprint often associated with these art museums, they are the backbone of many of today’s most prized art collections like the British Museum of Art and the Louvre.



Johan Zoffany, *The Tribuna of the Uffizi*, 1810; from the Royal Collection Trust.

2. “The Tribuna of the Uffizi,” The Royal Collection Trust, last modified 2016, <https://www.royalcollection.org.uk/collection/406983/the-tribuna-of-the-uffizi>.

## Enlightenment

The concept of the National museum only emerged in Europe during the Age of Enlightenment, when reason was at the forefront of establishing ideas on; aesthetics, ethics, government, and religion. It was a time where the new hegemony of the nation-state set out to foster national pride and civic identity among the populace. In 1753, a seventeenth-century mansion is converted into the British Museum of Art in London; in 1764, a palace is converted into the Hermitage in St. Petersburg; in 1793, a another palace is transformed into the Louvre in Paris. These three examples, containing collections—previously intended to cement royal power—were now a part of the public sphere. Similarly, buildings were constructed throughout Europe, South America, Asia, Africa, and the United States.

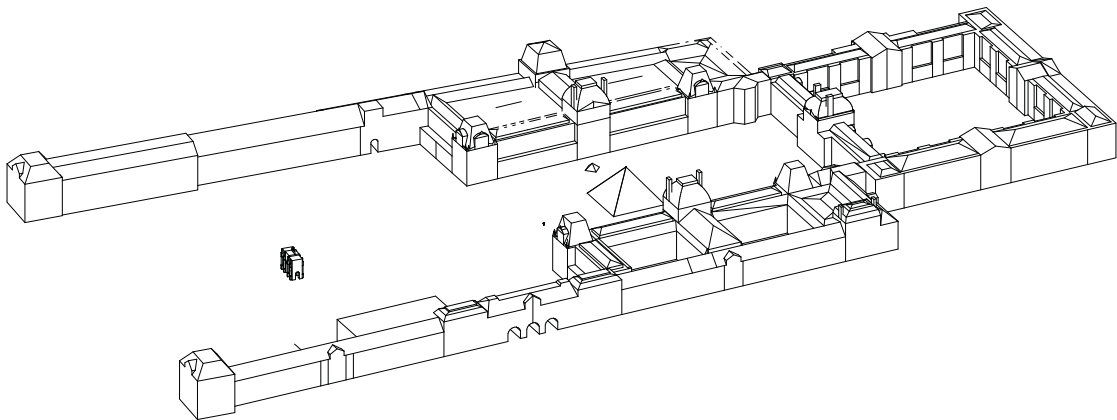

3D Axonometric of the Louvre, Paris

## Paradigmatic Shift

Although museum production virtually came to a halt for the first half of the twentieth century, after the two world wars and the great depression, the second half of the century experienced a surge in the construction of public cultural institutions. Characterized as a time of unparalleled progress in technology and scientific understanding, the century began with horses and trains and ended with commercial air and space travel. These advancements, along with many others, changed the way people lived in every way imaginable, including the direction of architecture and art.

In 1917, a time where a slew of avant-garde movements were attempting to define the potential face of modern art, a seminal moment in this art history occurred when the accomplished French painter, Marcel Duchamp, purchased an ordinary urinal, turned it upside down, titled it, called it *Fountain*, and displayed it as his original work of art. Spearheading the American Dada movement, he challenged the very definition of art, and with his refusal to follow the conventional artistic path and his introduction of the 'ready-made', he broke from the historical cannon and paved the way for others to do the same. This new philosophy brought an onslaught of varied media in all shapes and sizes throughout the art world; over the course of the twentieth century, performance, installation, video, and audio art began to emerge. During this time, practices shifted and were no longer relegated to sculpture and painting. This fast-paced change and new definition of art naturally had a deep influence on the shape of architecture for art. The most notable example is the Museum of Modern Art in New York.



Marcel Duchamp, *Fountain*, 1917;  
photograph by Alfred Stiegliz, from *Tootfuit*.

Despite the growing list of architects who have contributed to the MoMA buildings over the years, the institution insists on maintaining its classic 21-foot high white box galleries, each limited to one entrance. The white box—a viewing platform devoid of any other refer-

ence—is believed to ensure full attention is given to the art instead of visually competing with it; just like the Louvre and the cabinets of curiosities, the MoMA is routed in a specific ideology, which reflects the rules of art presentation related to the Modernist movement. For instance, paintings are to be hung at a specific eye level and separated at a distance to ensure only one image is in the viewer’s peripheral vision. Art critic and artist, Brian O’Doherty argues, this is a closed system of values, similar to other spaces of formality. He compares the white box to, “The sanctity of the church, the formality of the courtroom, the mystique of the experimental laboratory joins with chic design to produce a unique chamber of esthetics.”<sup>3</sup> An art museum following this strict set of rules is what Germain Bazin calls, “a clinic for masterpieces”.<sup>4</sup>



Photograph of a typical gallery space in the Museum of Modern Art (MoMA), NY

It can also be argued such foundational neutrality, where the space is void of significance and the viewer is free from any other concepts other than the work, cannot exist. The very act of art experience is to impose meanings, derived from non-neutral eyes acquired through experience; therefore, the ‘neutral’ museum is not neutral at all.

- 
3. Brian O’Doherty, *Inside the White Cube: The Ideology of the Gallery Space* (1st Book ed. Santa Monica: Lapis Press, 1986), 14.
  4. Germain Bazin, *The Museum Age*, trans. Jane van Nuis Cahill (New York: Universe Books, 1967), 265.

## The Boom

Since 1970 more than six hundred new art museums have opened in the United States, bringing the total to more than thirteen hundred galleries.<sup>5</sup> As previously mentioned, art museums have become more plebeian, now competing with other popular forms of entertainment, they include café's, restaurants, shops, theatres, and accommodate an array of large events. Art museum openings are met with much anticipation and tickets to popular travelling exhibitions are sought after as if they were the finals in a sporting event. This new wave is partly due to a change in mandate on behalf of the art museum, but often, the draw is the architecture.

In her influential book, *Towards a New Museum*, Victoria Newhouse praises the Guggenheim NY, designed in 1959 by Frank Lloyd Wright, for establishing a new kind of art museum architecture.<sup>6</sup> Rejecting the modern box, the Guggenheim's expressive sculptural presence is defined by a series of cylindrical stacked shapes which expand out towards the city while the interior is a single swoop of dramatic curves encasing a central atrium. Upon entering the building, the visitor is instantly rewarded with an extraordinary spatial experience. In designing the Guggenheim, Wright redefined the relationship between the museum and the city and challenged the modernist rules of art presentation.

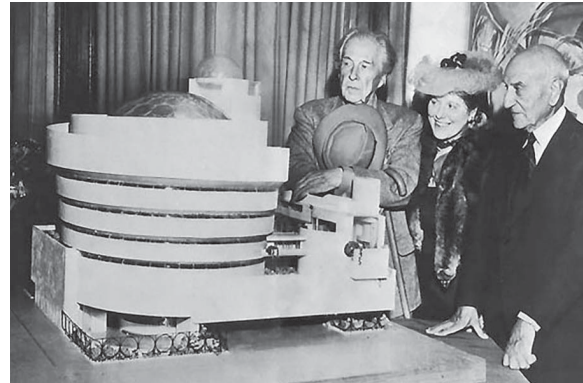
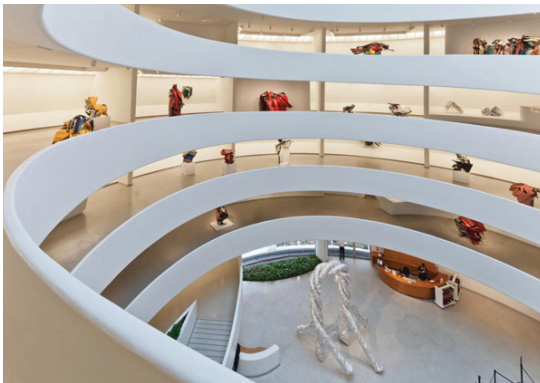

Two Photographs of the Guggenheim, NY; from the Guggenheim Archives.

Although the Guggenheim, NY is revered as a sculptural space, it has received much criticism on the grounds of function alone. The main critique is its lack of versatility: the curved walls only accommodate smaller rectilinear works and the continuous ramp discourages

5. Victoria Newhouse, *Towards a New Museum* (New York, N.Y.: Monacelli Press, 2006), Inside cover.

6. *Ibid.*, 10.

moments of pause, nudging the viewer along the promenade. The museum's then Director James Johnson Sweeney, described the building as the most spectacular museum interior architecturally in the country, but that his job was to show off a magnificent collection to its fullest.<sup>7</sup> The rotunda's inability to accommodate a large array of works forced the museum to build a rectilinear addition 33 years later.

Nevertheless, the Guggenheim encouraged the development of other exploratory ideas in art gallery design. Following the Guggenheim, NY, is the Centre Pompidou in Paris, designed by Richard Rogers and Renzo Piano in 1971-77. The museum's fruition was propelled by then president Georges Pompidou, who envisioned an iconic cultural centre that would become an integral monumental aspect of the city. Conceived as a fun house, a place where creativity and experimentation are encouraged; the large plaza is both a breeding ground for local activities and a place to watch the visitors move throughout the building. Its structure and systems turned inside out and glorified, the escalator on the exterior west façade carries the visitor to the top for a breathtaking view of the city. Like the Guggenheim in Bilbao, its success in engaging the public and revitalizing a derelict area was unprecedented. The art spaces are relatively traditional in their white box quality, with moments on the exterior where art and architecture meld together as one.



Photograph of the Centre Georges Pompidou. From the Conservapedia website.

7. "AD Classics: Solomon R. Guggenheim Museum / Frank Lloyd Wright," Adelyn Perez, ArchDaily, accessed 12 Jun 2015, <http://www.archdaily.com/?p=60392>.

## Bilbao Effect

Among the hundreds of art museums established throughout the Western world in the latter part of the 20th century and into the 21st century, perhaps the most notable example of the new kind of architecture Newhouse describes is Frank Gehry's sculptural masterpiece in Bilbao, Spain. Home to the country's main metal industries, the city suffered a tremendous blow during the economic crisis in the 1980's. Then an industrial wasteland, the city council was looking for an economic revival. As part of a greater master plan to develop the waterfront, the new Guggenheim transformed the former industrial powerhouse into an international cultural destination. Gehry explains his intent:

I wanted the Guggenheim Bilbao to have an iconic presence in the city. I wanted it to work for the arts. I wanted it to connect to the city, to the bridge, to the water, to the 19th century, so that it became a usable part of the city in the same spirit that Hans Hollein made the Stadtische Museum Abteiberg in Monchengladback in its relation to the church and to the small town....,that is the spirit of urbanism I tend to be interested in.<sup>8</sup>

Bilbao's success as an exhibitor of its contents has been repeatedly debated, but its impact on city, country and the world is indisputable. British Architect and writer, Michael Brawne, credits the 'Bilbao effect' for proving two things: "First, that a city, and possibly even a whole region, can profit from a new museum, and secondly, that architecture had finally become emancipated from the art exhibited inside it"<sup>9</sup> Since Bilbao, museums attempting to have a similar impact on other communities have sprung up throughout the globe, pining for a cultural catalyst of their own.



Guggenheim Museum, Bilbao, Spain, 1997; from Guggenheim Bilbao Museoa.

- 
8. Gerhard Mack and Harald Szeemann, *Art Museums into the 21st Century* (Basel: Boston: Birkhäuser, 1999), 27.
  9. Vittorio Magnago Lampugnani, and Angeli Sachs, *Museums for a New Millennium: Concepts, Projects, Buildings* (Munich: Prestel, 2001), 3.

## Bilbao Defect

In attending the opening of Bilbao, then director of the Denver art museum, Lewis Sharp, was inspired by its curvilinear form and excited by the energy expressed by the greater community, resulting in a campaign to do the same for his city.



Extension to the Denver Art Museum; from the Daniel Libeskind.



Two Interior photographs of the Denver Art museum , Denver, CO.

Since opening in 2006, the new Denver art museum's angular gallery spaces have been accused of upstaging its contents. As a centerpiece of Denver's cultural district, the jagged angular form, reminiscent of the nearby glaciers, commands all the attention. The building exudes an aggressive amount of energy. As the central staircase guides visitors through the building, cuts of daylight enter slotted windows, and intersecting geometries converge and collide sporadically. The building is a jungle, a place where gallery-goers loose themselves in the chaos of the surroundings, and it has been repeatedly criticized



by the architectural community as detrimental to its contents. In his article *A Razor-Sharp Profile Cuts Into a Mile-High Cityscape*, the New York Times Architecture Critic Nicolai Ouroussoff expresses his disappointment in Libeskind's work.

The new addition to the Denver Art Museum captures all of the contradictions within Mr. Libeskind's oeuvre. Its bold, often mesmerizing forms reaffirm the originality of his talent, yet its tortured geometries make it a daunting place to install or view art — hardly a minor drawback. And for all its emotional power, the building seems eerily out of date, and its flaws readily apparent.<sup>10</sup>

Similar to Bilbao, The Denver Art Museum is an icon-driven project, yet contrary to its precursor, it fails in achieving its ambitious intentions for art, architecture, and city.

### Helsinki Competition

A Contemporary example demonstrating the power of the 'Bilbao Effect' is the 2014 release of more than 1700 entries for the Guggenheim's new Helsinki satellite art museum. With predominant themes in competition entries having little to do with art presentation, and everything to do with producing an international icon. The majority of submissions were met with immediate ridicule from all types of stakeholders. Rory Hyde, curator of Contemporary Architecture & Urbanism and author of *Future Practice: Conversations from the Edge of Architecture*, impulsively went to twitter to express his opinion:



Twitter Status update; from Rory Hyde.

Many of Helsinki's very own inhabitants, also expressed their dissatisfaction by launching a counter international competition called Next Helsinki. Seeking proposals aimed at the improvement of the cultural and public essence of the city, the organization (spearheaded by a group of artists and designers) could not understand why the city would, "surrender

10. Nicolai Ouroussoff, "A Razor-Sharp Profile Cuts Into a Mile-High Cityscape." The New York Times, October 11, 2006, accessed October 31, 2014.

such a fabulous site to some starchitect supermarket...for a gaudy global repository.”<sup>11</sup>



Two Guggenheim Helsinki Design Competition entries; from the Guggenheim Helsinki.

Now that the competition is over, the jury has sifted through the pile of submissions and found their diamond in the rough. The winners, Moreau Kusunoki Architectes, appear to have succeed in implementing a sensitive, thoughtful, and productive response to the relationship between the architecture, the art, and the city; yet, when describing the winning entry, the Guggenheim foundation eloquently paints a picture of a dynamic relationship between the architecture and the city, and fails at sufficiently addressing the art it holds.



Guggenheim Helsinki Design Competition winner, 2015; from the Guggenheim Helsinki.

11. "The Next Helsinki" The Next Helsinki, accessed February 20, 2015, <http://www.nexthelsinki.org/>.

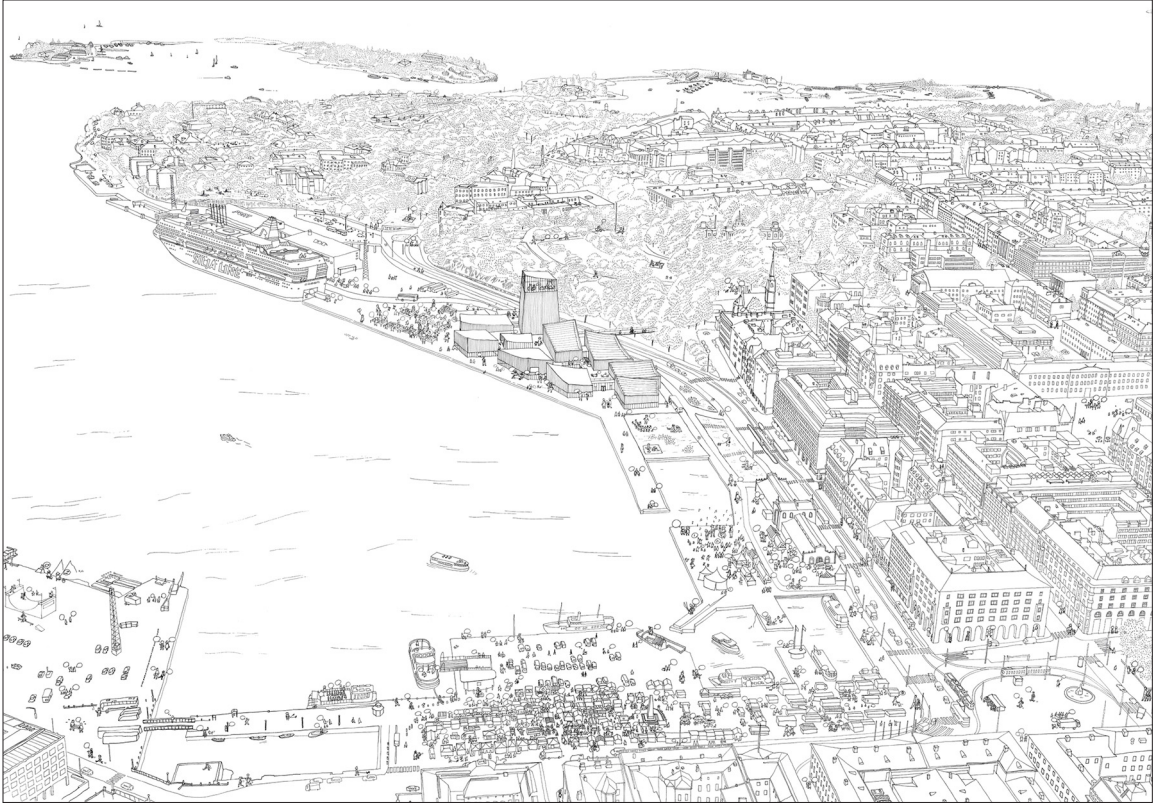

Guggenheim Helsinki Design Competition winner, 2015; from the Guggenheim Helsinki.

Throughout the centuries, the role of art museums and galleries have evolved from their nascent beginnings as the Renaissance's cabinet of curiosities, into the late eighteenth-century national museum, and to the early twentieth century neutral white cube; now, the high-paced competition between cities on the international stage is substantial, and since Bilbao, iconic buildings have become an integral contributor in establishing the identity of a city. After countless failed projects, we are beginning to see the after effects of these buildings, spawning the question, is this the right approach? Organizations such as, "Next Helsinki" are demanding a more inclusive and local philosophy to the design of their city; they imagine, "a richer future for the whole city," and are interested in developing cultural strategies that come from the local fabric. In a sense, they are looking for a true Icon, an image derived from a place.

## CONTAINER + CONTENTS

### Icon

Iconic architecture in the traditional sense is usually associated with buildings such as the Sydney Opera House, the Guggenheim in Bilbao, and the Gherkin in London. The Greek word *eikon*, which means “picture, image, or other representation.” It can also mean, “a person or thing regarded as a symbol of a belief, nation, community, or cultural movement.”<sup>12</sup>

In a contemporary Western context, iconic status is gained by recognition via a distinct silhouette or technological breakthroughs such as The Statue of Liberty, or the Eiffel Tower; yet, when architects and communities actively seek this level of iconic status, the resulting building often lacks meaning and timelessness. Busquets and Correa outline the danger in pursuing the icon, and propose a shift in perspective:

It is evident that the most successful iconic projects are those that can deliver a highly innovative product while they maintain an intellectual and discursive rigor that goes beyond effective branding techniques. Iconic projects that transcend the effects of fashion and operate at more than one level in the city are ones that establish a successful presence, cast an operative net that goes far beyond their physical boundaries, and harvest positive results for many decades.

An iconic building celebrates with its salient form a particular place, time, and/or location. When a number of uninspired applications of iconic buildings are erected within a city, the result is often a meaningless collage of disparate icons. A key building, by contrast, goes beyond salient form to deliver a challenging program that can accommodate a broad range of actions within a particular location. A key building, thereby, operates as an elegant and unifying catalyst for a comprehensive and physically influential set of actions for a city.<sup>13</sup>

Busquets and Correa establish a new dialogue in the pursuit of an icon and create an alternative set of criteria with which to design all public buildings.

### Container vs Contents

As previously explained, art museums represent a moment in history and are products of their time—their design is directly influenced by their context and their contents. The contestation between container and contents is only a recent debate, but it is now at the forefront of contemporary museum design projects. To shed light on this matter, in her

12. “Icon,” The Free dictionary, accessed January 20, 2014, <http://www.thefreedictionary.com/icon>

13. Joan Busquets, Felipe Correa, *Cities X Lines: A New Lens for the Urbanistic Project* (Cambridge, MA, Harvard University, Graduate School of Design, 2006), 41.

book *Towards a New Museum*, Victoria Newhouse writes:

I question the validity of growth that often strains the very concepts on which a museum was founded and address institutional attitudes toward art and architecture that clearly give priority to art, often to the detriment of both architecture and, more important, the relationship between the two.<sup>14</sup>

In contrast to this thesis, Newhouse concludes with an argument for the container:

The new museum's extraordinarily distinctive architecture—as site specific as art so designated promises to go a long way toward erasing the distinction. Whereas museums have always identified with their collections—the Louvre is the Mona Lisa, MoMA is Les Femmes d'Alger—Avignon—the new museum is identified with its architecture: the dominant image is the container rather than the contents.<sup>15</sup>

But what about the art? When does the architect's vision impede that of the artist? Does the iconic nature of the building detract from the importance of the work inside? At what point does the interior structure distract the viewer from the art? Can architecture and art enrich one another?

## Research Scope

Although the debate between container and contents, is a global phenomenon, the United States emerged as a particular area of interest. Since 1970, an unprecedented amount of art museums have been built throughout the country, and as mentioned earlier, the United States boasts more than thirteen hundred galleries and art museums, many designed by some of the most renowned architects of our time. By travelling between major city centres throughout the United States, I was able to visit a diverse selection of seminal architectural manifestations in distinctly different communities, with a range of mandates, architects, and levels of success. To supplement my research I traveled to France, the United Kingdom, and Italy, to visit some of Europe's most iconic art museums.

---

14. Victoria Newhouse, *Towards a New Museum* (New York, N.Y.: Monacelli Press, 2006), 10.

15. *Ibid.*, 260.

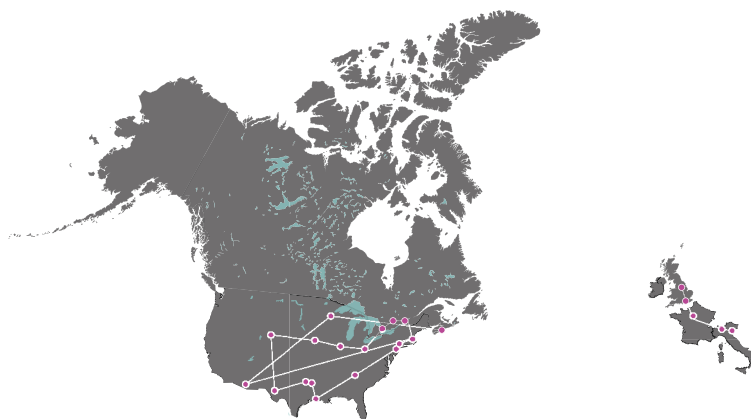

1. AGNS, Halifax, NS 2. ICA, Boston, MA, 2006 - **Diller Scofidio+Renfro** 3. Museum Of Fine Arts, Boston, MA, 2010 - **Foster and Partners** 4. Guggenheim, New York, NY, 1959 - **Frank Lloyd Wright** 5. The New Museum, New York, NY, 2007 - **Sanaa** 6. Dia Beacon, Dia, NY, 2003 7. PS1, New York, NY, 1997 - **Frederick Fisher Architects** 8. High Museum of Art, Atlanta, GA, 1984 - **Richard Meier**, 2002 - **Renzo Piano** 9. CAMH Houston, TX, 1972 - **Gunnar Birkerts** 10. Museum of Fine Arts Houston, TX, 1958 - **Ludwig Mies van der Rohe**, 2000 - **Rafiel Moneo** 11. Rothko Chapel, Houston, TX, 1971 - **Mark Rothko & Philip Johnson** 12. Menil Collection, Houston, TX, 1987 - **Renzo Piano** 13. Cy Twombly Gallery, 1995 - **Renzo Piano & Cy Twombly** 14., Dallas Museum of Art, Dallas, TX, 1984 - **Edward Larrabee Barnes** 15. Nasher Sculpture Centre, Dallas, TX, 2003 - **Renzo Piano** 16. Modern Art Museum, Fort Worth, TX, 2002 - **Tadao Ando** 16. Kimbell, Fort - **Louis L. Kahn**, 2013 - **Renzo Piano** 17. The Chinati Foundation, Marfa, TX, 1986 18. MOCA Tucson, Tucson, AZ, 1996 19. Denver Art Museum, Denver, CO, 2006 - **Daniel Libeskind** 20. Clyfford Still Museum, Denver, CO, 2011 - **Allied Works Architects** 21. Museum of Contemporary Art, Denver, CO, 2007 - **David Adjaye Associates** 22 Nelson Atkins Museum, Kansas City, MO, 2007 - **Steven Holl Architects** 23. Kemper Museum of Contemporary Art, Kansas City, MO, 1994 - **Gunnar Birkerts Architects** 24. Nerman Museum of Contemporary Art Kansas City, MO, 2007 - **Kyu Song Woo Architects** 25. Pulitzer Foundation for the Arts, St. Louis, MO, 2001 - **Tadao Ando** 26. Contemporary Art Museum, St. Louis, MO, 2003 - **Allied Works Architects** 27. Contemporary Art Centre, Cincinnati, OH, 2003 - **Zaha Hadid** 28. Walker Art Center for the Arts, Minneapolis, MI, 2005 - **Hertzog + de Meuron** 29. Weisman Art Museum, Minneapolis, MI, 1993 - **Frank Gehry** 30. Ryerson Image Centre, Toronto, ON, 2012 - **Diamond and Schmitt Architects** 31. Art Gallery of Ontario addition, Toronto, ON, 2012 - **Frank Gehry** 32 MOCA, Toronto, ON 33. National Gallery, Ottawa, ON, 1998 - **Moshe Safdie** 34. The Saatchi Gallery, London, England, UK, 1985 - refurbished by architects **Paul Davis + Partners** and Allford Hall Monaghan Morris. 35. The National Gallery, London, England, UK, 1824 - **William Wilkin** 36. Tate Modern, London, England, UK, 2000 - **Hertzog & de Meuron** 37. Serpentine Gallery, England, UK, Established 1970 - Former tea pavilion 1933-34 - **J. Grey West**. 38. Slacker Gallery Extension, London, England, UK, 2013 - **Zaha Hadid** 39. Tate Britain, London, England, UK, 1897 - Sidney R. J. Smith, John Russell Pope, James Stirling, 2013 - Caruso St John 40. British Museum, London, England, UK, 1823-52 - **Sir Robert Smirke**. 2000 - Elizabeth II Great Court - **Foster and Partners** 41. V&A, London, England, UK, 1852\ 42. Hepworth Wakefield Art Gallery, Wakefield, West Yorkshire, England, 2011 - **David Chipperfield Architects** 43. The Louvre, Paris, France, 1981-2002 - Pyramid renovation by **I. M. Pei** 44. Musee D'Orsay, Paris, France, 1986 - **Gae Aulenti** 45. Palais De Tokyo and Musee d'Art Moderne de la Ville de Paris, 1937 - For the International Exhibition, 1974 - Lacation & Vassal 45. Centre Georges Pompidou, Paris, France, 1971-1977 - **Richard Rogers and Renzo Piano** 46. Fondazione Prada, Milan, IT, 2015 - **Office of Metropolitan Architecture** 47. Venice Biennial, Venice, IT, Since 1895

Map of museums visited as part of research scope; base map from the Freepik website.

## Layout Strategies

In spite of an indeterminate amount of variety throughout the case studies, clear systems of order and similarity were simultaneously noted.

### TUNNEL

NASHER, DALLAS  
KIMBELL, FORT WORTH  
DIA BEACON

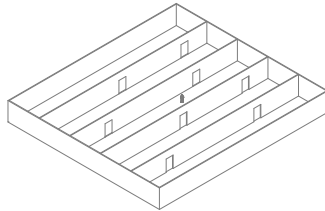

### STACK

NEW MUSEUM, NY  
SPERONE, NY

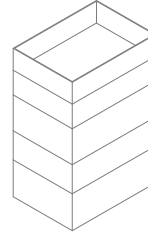

### NEUTRAL

ICA, BOSTON  
MOCA, TORONTO  
AGO, ADDITION, TORONTO

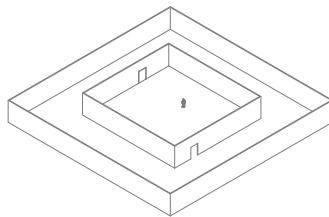

### DYNAMIC

PULITZER FOUNDATION, ST LOUIS  
CONTEMPORARY ART M., ST LOUIS  
CACC, CINCINNATI  
FONDAZIONE PRADA, MILAN

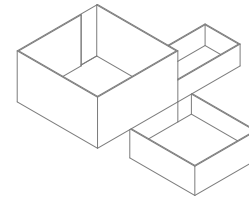

### ENFILADE

AGNS  
MUSEUM OF FINE ARTS, BOSTON  
MUSEUM OF FINE ARTS, HOUSTON  
ART GALLERY OF ONTARIO  
THE LOUVRE, PARIS

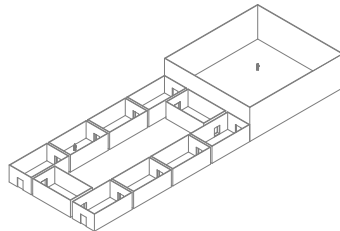

### CORRIDOR & SUITES

PS1, NY  
MENIL, HOUSTON  
NELSON ATKINS  
RYERSON IMGAE CENTRE  
TATE MODERN

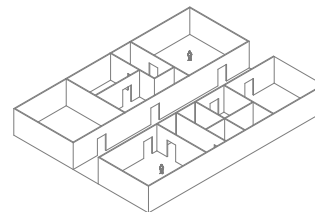

### SUITES

DIA BEACON, BEACON  
CY TWOMBLY, HOUSTON  
CLIFFORD STILL, DENVER

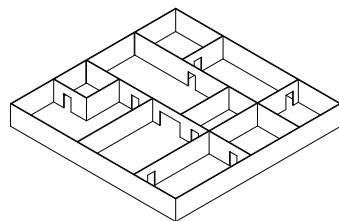

### SKIN & BONES

KEMPER, HOUSTON  
MUSEUM OF FINE ARTS, HOUSTON  
HIGH MUSEUM OF ART, ATLANTA  
CENTRE GEORGES POMPIDOU, PARIS

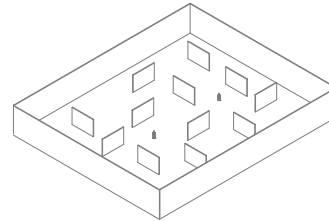

Diagrams establishing a classification system by layout strategy.

## Strategic Positioning

The following is a series of selected buildings from the research scope. Three key urban themes emerged: A museum by the water, a museum in a park and a museum at the centre.

**WALKER ART CENTER**  
MINNEAPOLIS, USA

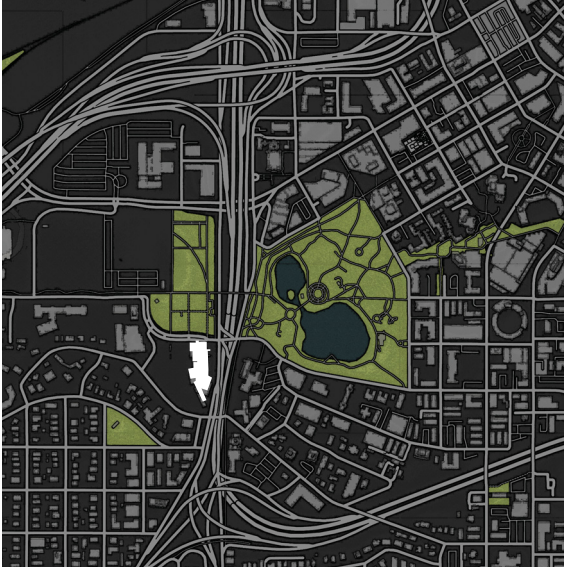

**THE LOUVRE**  
PARIS, FRANCE



**THE NELSON ATKINS MUSEUM**  
KANSAS CITY, USA



**NATIONAL GALLERY**  
OTTAWA, CANADA

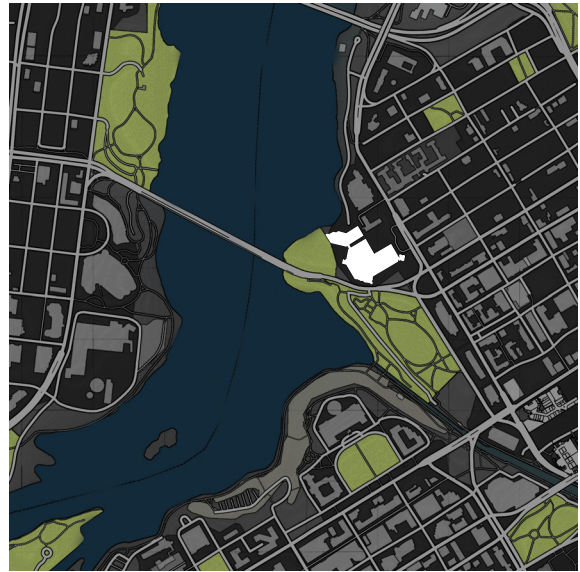

Scaled urban studies of major art museums throughout the western hemisphere;  
base maps from Google.



MUSEUM BY THE WATER  
IN A PARK  
AT THE CENTRE

THE MET  
NY, USA

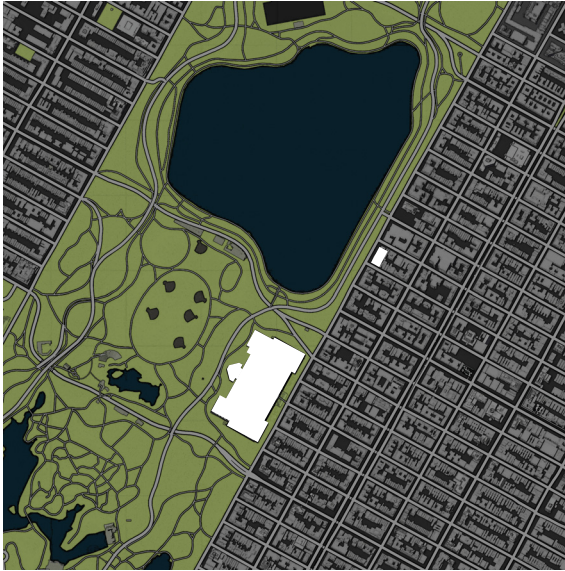

THE MODERN & THE KIMBLE  
FORT WORTH, TX

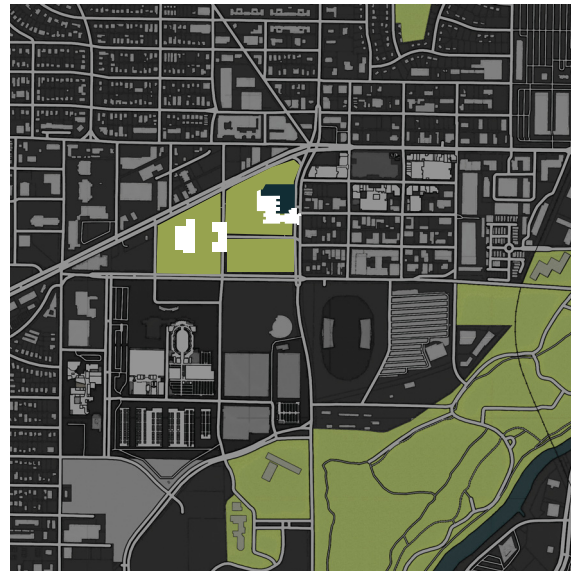

THE BRITISH MUSEUM  
LONDON, ENGLAND

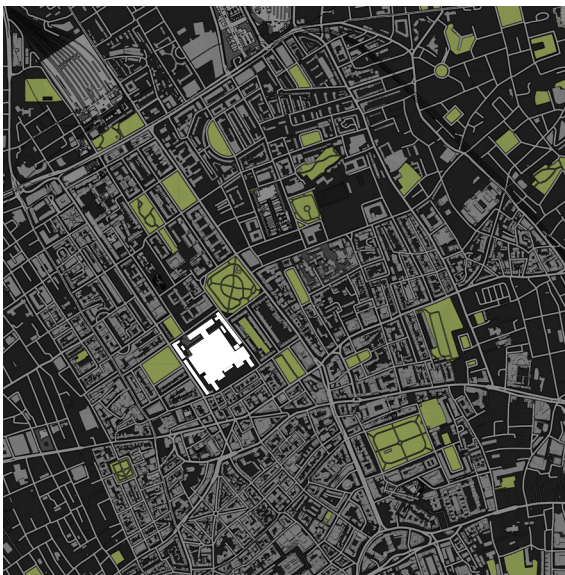

DENVER ART MUSEUM  
DENVER, USA

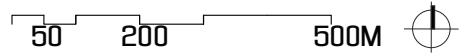
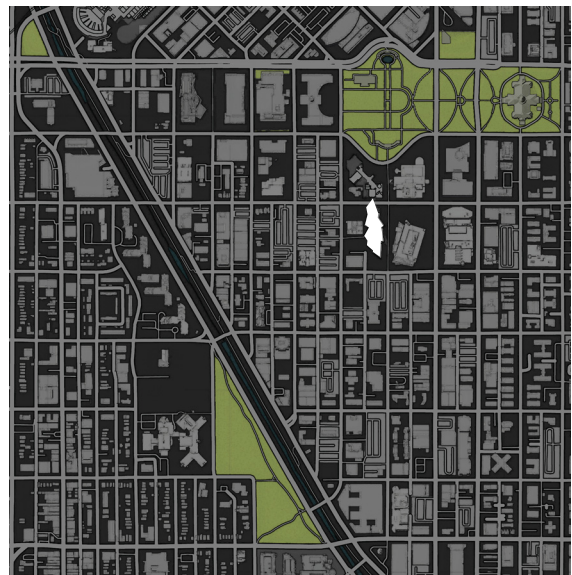

Scaled urban studies of major art museums throughout the western hemisphere base maps from Google.

## Three Key Distinctions

Throughout the research scope, a series of quantitative and qualitative data was analysed; year of completion, overall size, number of visitors per annum, program variation, exhibition space variation, lighting strategies, relationship to the city, audience participation, and overall viewer experience. From the galleries studied, three key qualitative distinctions emerged: Productive, Detrimental, and Neutral.

### Detrimental



Photograph of the Museum of Fine Arts, Boston, MA.



Altered photograph of the Museum of Fine Arts, Boston, MA.

Designed by Foster and Partners, the space is situated in the Modern art section of the Museum of Fine Arts, in Boston, MA. The skylights coupled with a 4' painted extension flanking the top for the partitioned walls, dominate the scene, causing the eye to wonder, with no place to rest. This is an instance where Author David Lauer explains in *Design Basics*, "Several focal points of equal emphasis can turn the design into a three-ring circus

in which the viewer does not know where to look first. Interest is replaced by confusion: when everything is emphasized, nothing is emphasized.”<sup>16</sup>

### Neutral



Photograph of the Aspen Art Museum, Aspen, CO.

Designed by Shigeru ban architects, the space is situated in the Aspen Art Gallery in Aspen CO. A typical white box gallery with ideal 16’ high ceilings. This type does nothing for the architecture, nor for the art.

### Productive

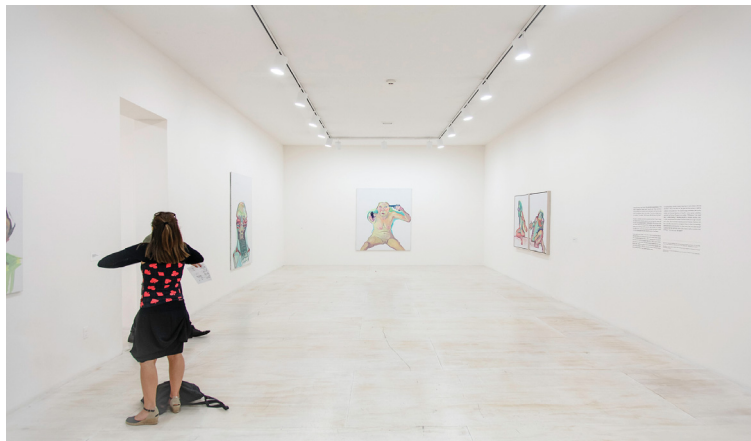

Photograph of the MoMA PS1, New York, NY.

Designed by Frederick Fisher, the space is situated in the MoMA PS1, in New York, NY. A typical white box gallery with 14’ ceilings; what’s more, the Addition of construction grade

---

16. David A. Lauer and Stephen Pentak, *Design basics, Fifth ed.* (Orlando, FL: Harcourt College Publishers, 2000), 56.

whitewashed plywood as a floor treatment, leads the viewer through an oscillating white field, engrossed by Maria Lassnig's paintings.

## Productive Tension

The photo depicting the MoMA PS1 and maria Lassnig's paintings is only one example from a rich library of samples where in my opinion, architecture and art join together and create a resonance far greater than each separate entity can achieve. To illustrate, I will turn to basic color theory. Complementary colors are on the opposite end of the color wheel, though, when joined together, the tension between the two intensify each other.

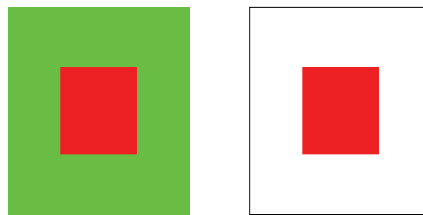

Diagram showing red and green complementary colors

The term “tension” is more often engrossed with negative overtones. Typically relating to strain, anxiety and excitement, often leading to unproductiveness and distress; alternatively, it can also be viewed in a positive light. Tension is intrinsically productive enabling a heightening one's sense of awareness and emotional state. Relating to the art museum, American philosopher Nelson Goodman writes:

The museum has to function as an institution for the prevention of blindness in order to make works work. And making works work is the museum's major mission. Works work where, by stimulating inquisitive looking, sharpening perception, raising visual intelligence, widening perspectives, bringing out new connections and contrasts, and marking off neglected significant kinds, they participate in the organization and reorganization of experience, in the making and remaking of our worlds.<sup>17</sup>

What Goodman describes is the very essence of great art museum architecture, and equally, great art. The moment where reverberation is maintained at a decibel between opposing forces and oscillate in collaboration, achieving a ‘productive tension’. To further elaborate, In her book *Architecture and the Sciences: Exchanging Metaphors*,” historian Antoine Picon's thoughts help to clarify:

---

17. Gaynor Kavanagh, *Museum Provision and Professionalism*, Leicester Readers in Museum Studies. London (New York: Routledge, 1994), 253.

Like other key dimensions of architecture, space was not a thing but an operator enabling a constant oscillation between the abstract and the tangible, the mobile and the motionless. Such an oscillation allowed the architect to design spaces that were both specific and imbued with universal meaning; in other words, it enabled architects to reconcile place and space.

Design, order and proportion, ornament, structure, and space—may help us understand the medium's strong virtual content. Architecture is not something stable. It appears through a series of productive tensions or potentials. Design, order and proportion, ornament, structure, and space are among these tensions or potentials that have made and still make works of architecture and, above all, architectural expression possible."<sup>18</sup>

What both Picon and Goodman describe is not an easy task, and I would argue, even more difficult when designing architecture for art. It's one thing to design for the known; but, with the explosion of art forms throughout the last century, and having to anticipate future artistic exploitations, designing space for art presents real challenges for architects. In describing an unsuccessful Rodin exhibit in the East Wing of the National Gallery in Washington, architecture critic and writer, Aida Louise Huxtable writes:

When a museum and its contents come together as an integrated aesthetic whole, something special happens. The art is enlarged and exalted, and so is the experience of the viewer. Creating that synthesis of art and setting is the challenge that still faces architects and directors. It is also the secret of a great museum.<sup>19</sup>

In my opinion, what Huxtable speaks of is not the white box, nor is it the extravagant shape for the sake of icon. The joining of forces she describes is derived from tension, the same kind of tension that makes a poem, a painting, or any artistic work exceptional. Similarly, by embedding a 'productive tension' between the container, contents, and context (the three C's), the result feeds the audience's hunger for an experience, through an undulation of entertainment, emotion, reflection, introspection and intellectual rigor.

The following pages show a series of diagrams outlining some of the strategies I used to achieve productive tension in designing the new Art Gallery of Nova Scotia.

---

18. Picon, Picon, Antoine, and Ponte, Alessandra, *Architecture and the Sciences: Exchanging Metaphors*, 1st ed. Princeton Papers on Architecture, New York (Princeton Architectural Press, 2003), 300.

19. Huxtable, Ada Louise, *On Architecture: Collected Reflections on a Century of Change*, 1st U.S. ed. (New York: Walker, 2008), 106.

# Ways of Achieving Productive Tension

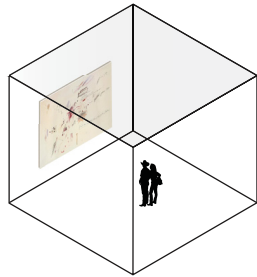

LIGHT FROM ABOVE

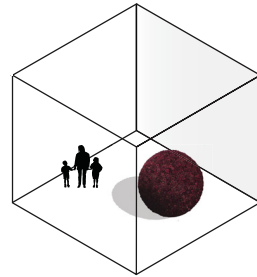

LIGHT WALL



HIGH MUSEUM OF ART, ATLANTA

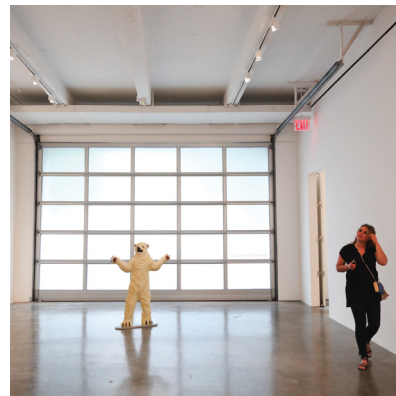

NY

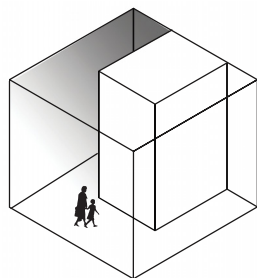

INDIRECT LIGHT

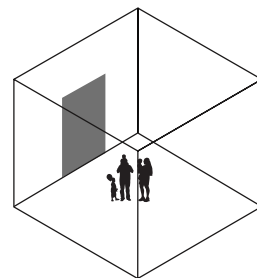

MAJOR ELEMENTS

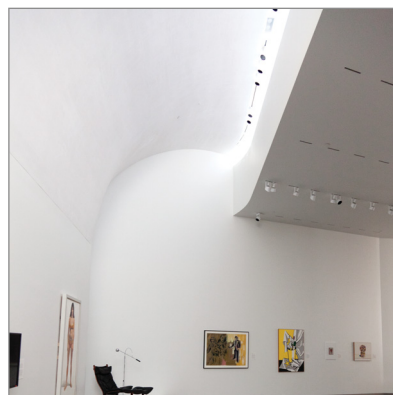

## Design Strategies

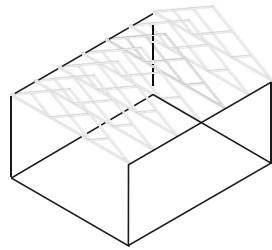

**STRUCTURAL ELEMENTS**



**CLYFFORD STILL MUSEUM, DENVER**

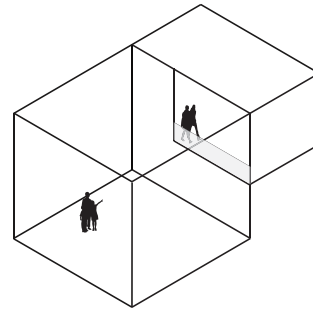

**VANTAGE POINT**



**THE MODERN, FORT WORTH**

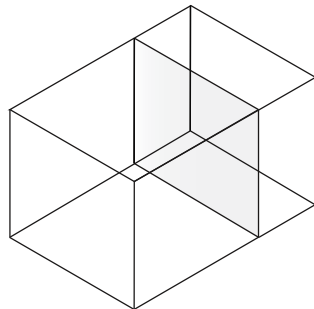

**CROSS-POLLINATION**

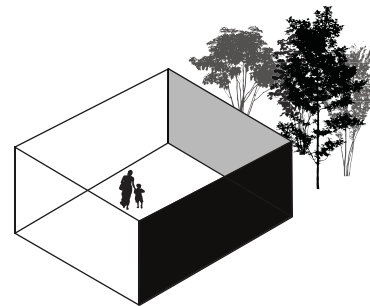

**LANDSCAPE**



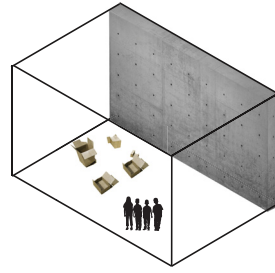

**SURFACE TEXTURE**



**THE MODERN, FORT WORTH**

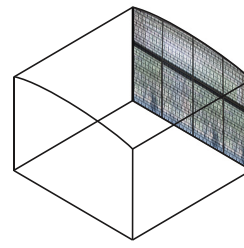

**STRUCTURAL LANGUAGE**

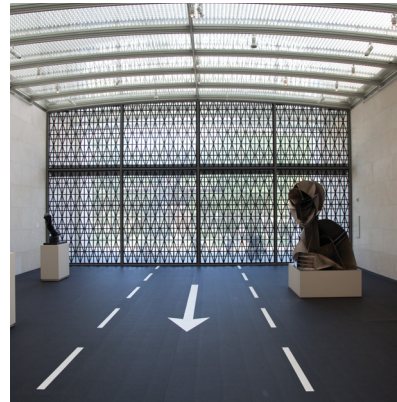

**THE NASHER MUSEUM OF ART, DALLAS**

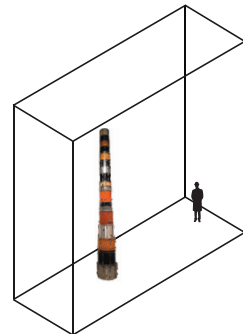

**PROPORTIONS**

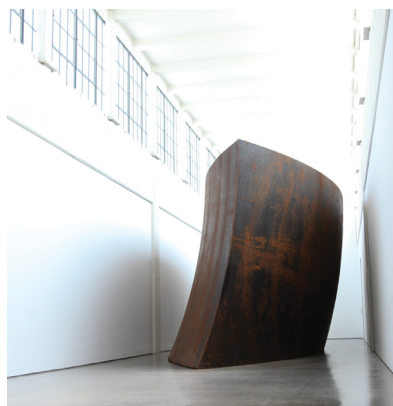

**DIA BEACON, BEACON**

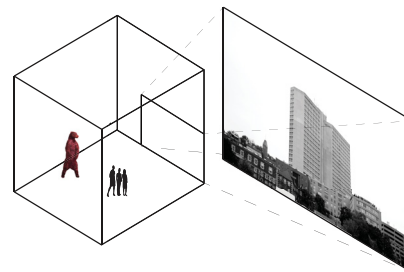

**CONNECTION TO THE CITY**

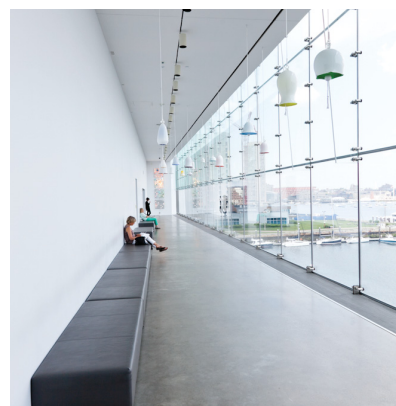

**ICA, BOSTON**



## CHAPTER 2: CONTAINER + CONTENTS + CONTEXT

### CONTAINER + CONTENTS

#### Test Case (Art Gallery of Nova Scotia)

Since its inception in 1908, the AGNS has expanded from its original mandate (to maintain the Crown's art collection of 200 works) to a primary institution for preservation, collection and presentation of visual art. Its permanent collection, now reaching over 15,000 objects, boasts a strong exhibition history showing contemporary and historic art from the province, region, country, and international community. It is also the creator of the annual Sobey Art Award—highlighting the most promising young Canadian artists—placing the institution at the forefront of contemporary Canadian art. The present day AGNS is at a crossroads. The collection, housed in a building originally designed for office use, is equipped with poor room dimensions, low ceiling heights, deteriorated building systems, and convoluted circulation. The current home of the AGNS is a container that is detrimental to its contents. If the institution stays in its current location, the art institutions growth will inevitably be stunted, risk a decline in its current status as a cultural incubator.



Exterior photograph of the Art Gallery of Nova Scotia, Halifax, NS.



Canadian Art



Maud Lewis House



Folk Art

Interior photos of the Art Gallery Of Nova Scotia

## CONTEXT

### Region

The Canadian province of Nova Scotia, also known as Mi'Kma'ki, is positioned at the tip of the Maritimes. As traditional hunting and fishing grounds of the Mi'kmaq, the province gained its current status after a brutal series of wars lasting 150 years, where the Mi'kmaq, along with the French and the Acadians, resisted British settlement. In 1761, the colonial wars ended with the Burial of the Hatchet Ceremony between the British and the Mi'kmaq.

From its early Mi'kmaq history to European settlement, to the present day, Nova Scotia's main attraction has been its rich natural environment via its network of lakes and forest, and its proximity to the ocean. This geography has continued to cultivate and perpetuate its activities. Although the province was originally advertised to European settlers as a sportsman's haven, abundant in wild game and brimming with natural beauty; its main draw belongs to its strategic location within the international community. In particular, the city of Halifax is a principle point of entry to North America, and it has been a key contributor in opening up international markets to the entire continent.

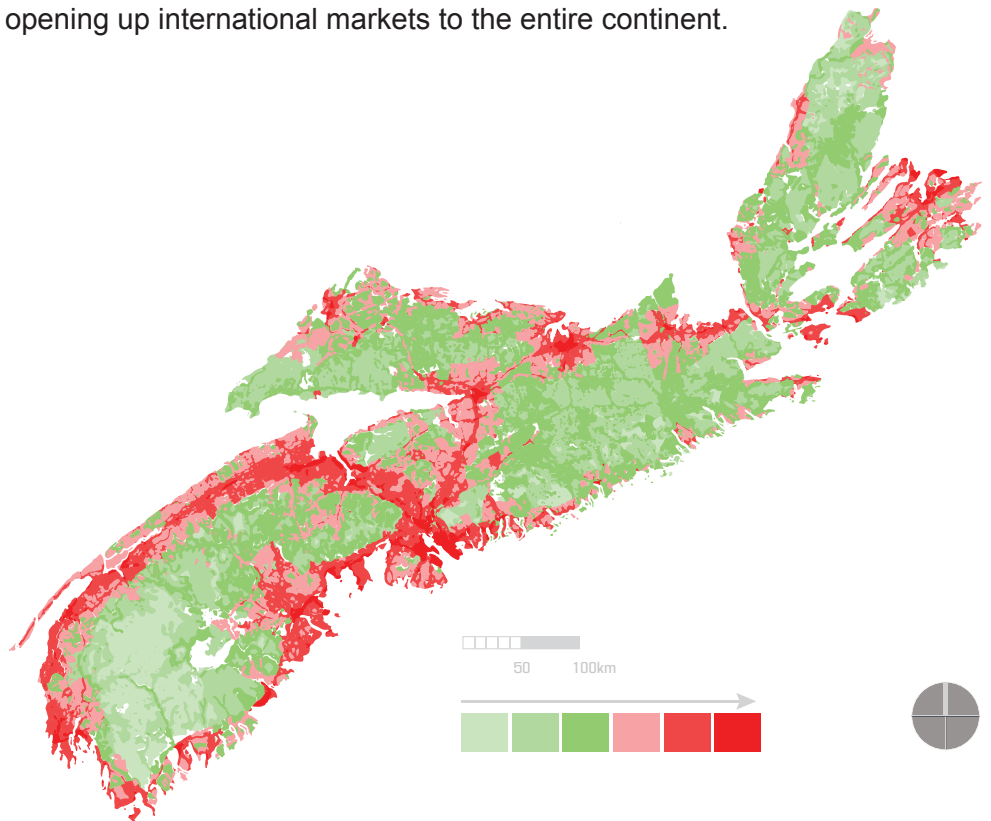

Detail: Map showing population and infrastructure density at its highest along the shoreline; base map from Two Countries and One Forest.

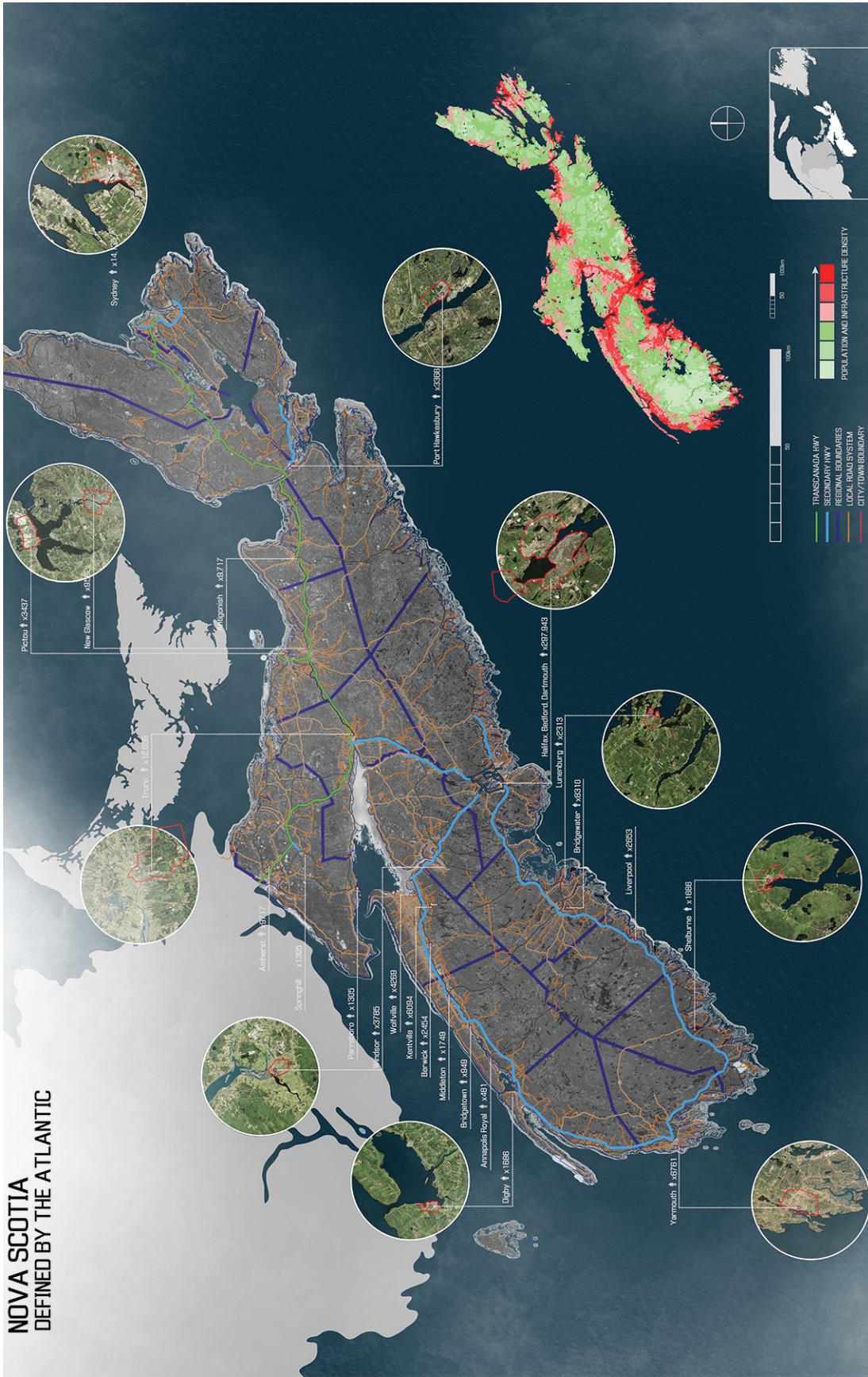

Map showing all major settlements situated in a series of bays and estuaries; map data from Google, Two Countries, One Forest, and the Nova Scotia Geomatics Centre.

## City

Originally a prime fishing spot for the Mi'kmaq and the Acadians in the summer months, in 1749, Halifax became Nova Scotia's capital for its protected Bedford basin and impressive harbour—the second largest natural harbour in the world. With settlements oriented to the waterfront and the main economic stimulus connected to the military and other shipping ventures, Halifax experienced 200 years of economic prosperity. In fact, the city can attribute the better part of its growth to times of war, playing an integral role in the Siege of Louisbourg, the American Revolution, the Napoleonic Wars, the War of 1812, the American Civil War, World War I, and World War II.

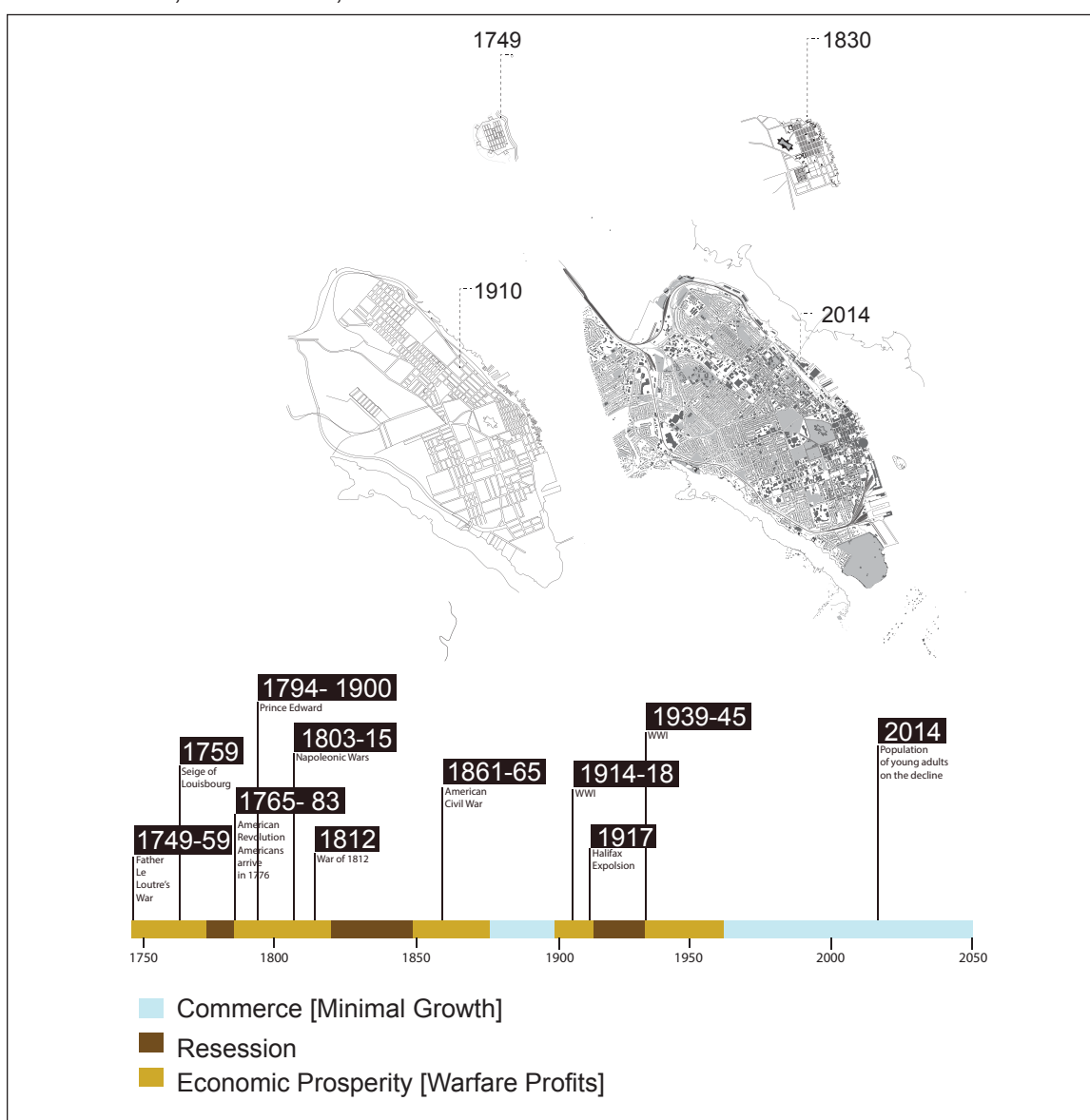

Timeline showing the direct relationship between war and prosperity; base maps from The Nova Scotia Archives

Interested in the physical realities of the city, I first approached the urban conglomerate of Halifax like a stranger—observing and wondering around, without considering the building laws and zoning plans. After careful analysis of the city, the area of concentration is characterized by a multitude of zones spread out through the central business district including; tourist destinations, art hubs, and undeveloped land.



HFX Harbour: View towards Dartmouth



Highway into the city



North end: Urban Residential



Citadel Hill



North end: Commercial district



Waterfront boardwalk

## City as Container



Collages exploring productive tension between art and city.



Collages exploring productive tension between art and city.



Rather than concentrating solely on the City of Halifax, the urban response considers beyond the city, extending to the entire province. The result is a specific expression of the entire region while providing a response that is consciously urban.

As previously determined, All of Nova Scotia has a deep-seated connection to the Atlantic, and Halifax is no different. The city's existing trade and commerce connectors such as; the railroad tracks along the water, the shipyards, the naval yards, the remnants of old finger piers, and road networks, all are clearly an expression of the city's relationship with nature. During the process of development, the city adapted and filled the natural space; yet, the history of the land bleeds through via the sporadic grid of the city.

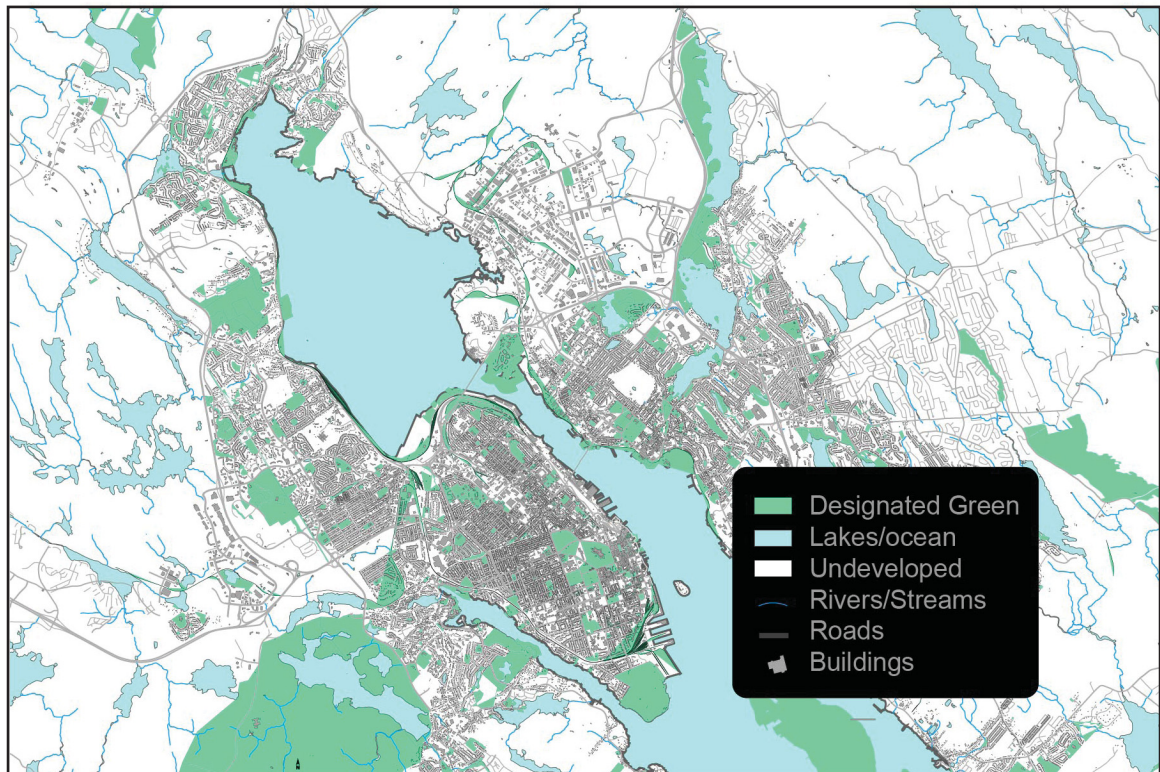

Map showing Halifax urban conglomerate and its close connection to nature; base map from GIS.

### Locating Site

At the city's edge lies the Halifax Harbor and the Bedford Basin; both natural phenomenon's, they provide protection for navy vessels and permit constant flow of goods to North America. The water is both a means of transport and an instrument for pleasure.

Mostly lined with industrial and military infrastructure, there are two banks on the harbor that are virtually impenetrable by pedestrian traffic; yet, things are changing. Technological advancements in shipping render much of the small-scale operations that occupied the inner city waterfront unnecessary and the border from land to ocean is becoming public via numerous initiatives by the city and province.



Photograph of the Wave, Waterfront Boardwalk, Halifax, NS.

The following Urban studies position the new AGNS at the precise centre of the Central Business District. In its new location, the art museum will be a highly visible landmark along the waterfront. Iconic, yet quiet and contemplative; taking up only a small section of the site, it secures the majority of the footprint for much needed public space. The site, currently an expansive parking lot, is a long-neglected area in the city's core.

Urban Studies



LAND USE

-  Boardwalk
-  Pedestrian
-  Public Parking
-  Buildings
-  Green Space



Land Use map showing the majority of surface parking to be situated on Halifax waterfront; base map from GIS and physical mapping.



## TOURIST MAP

1. Georges Island
2. Citadel Hill
3. King of Donair
4. Willie's Poutine
5. Historic Properties
6. Waterfront Boardwalk
7. Wave
8. Clock Tower
9. Graveyard
10. Public Gardens

11. Peier 21
12. Harbour Market
13. Commons
14. Art Gallery of Nova Scotia
15. Maratime Museum
16. Natural History Museum
18. St. mary's Basilica
19. province House
20. Discovery Centre
21. Casino Halifax
22. City Hall

- Heritage
- Buildings
- Museums
- Green Space
- Gov. / Schools
- Roads



Tourist Map showing the majority of tourist destinations to be within 20-minute walking distance; base map from GIS and physical mapping.



## ART HUBS

- Exterior Temp. Venue
- Artist Run Centre
- Interior Temporary
- Museum Temp Exhibits
- Commercial Gallery
- Pop Explosion
- Universtity Art Gallery



Art Hub map showing the majority of art hubs to be within 20-minute walking distance; base map from GIS and physical mapping.

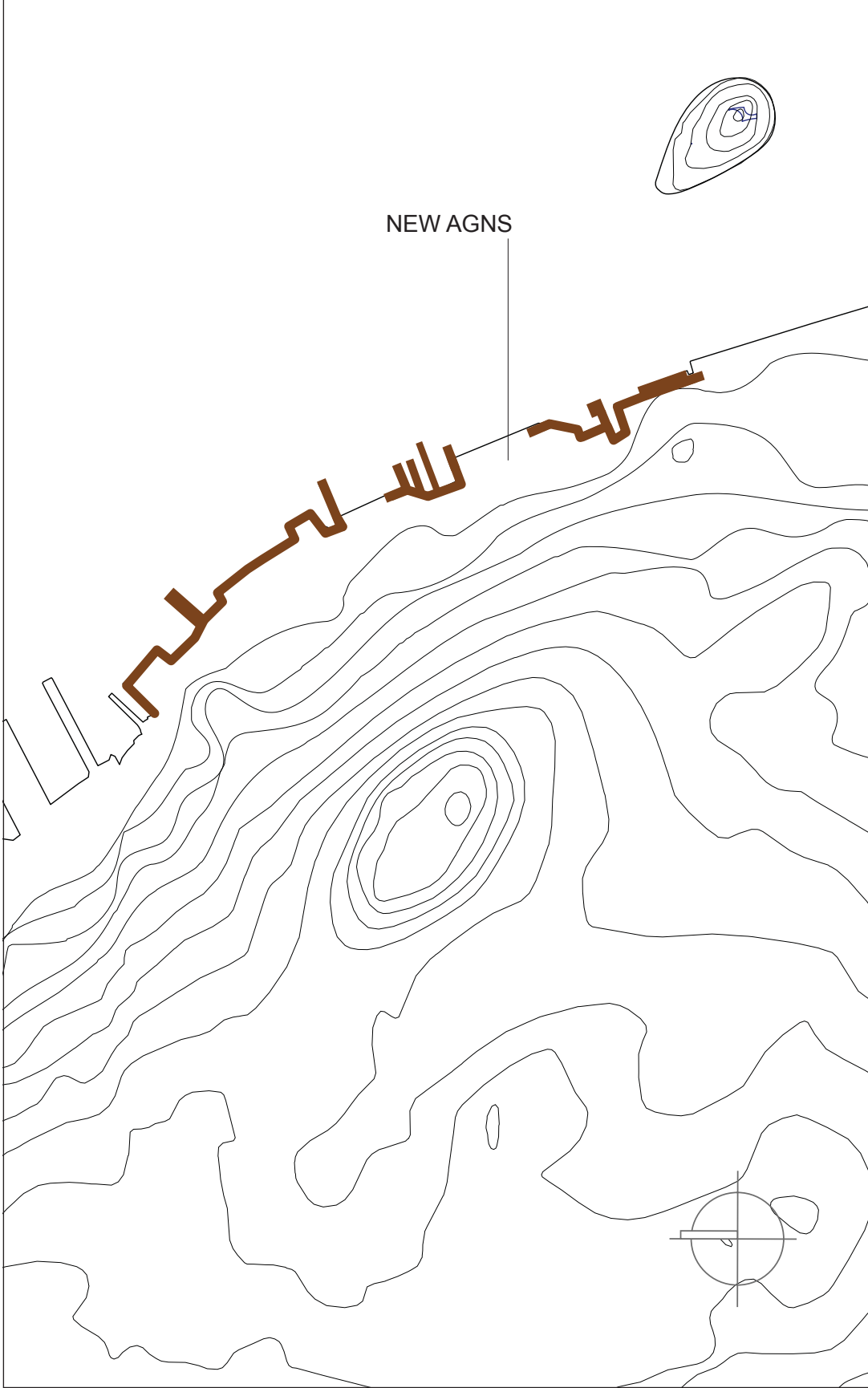
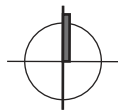
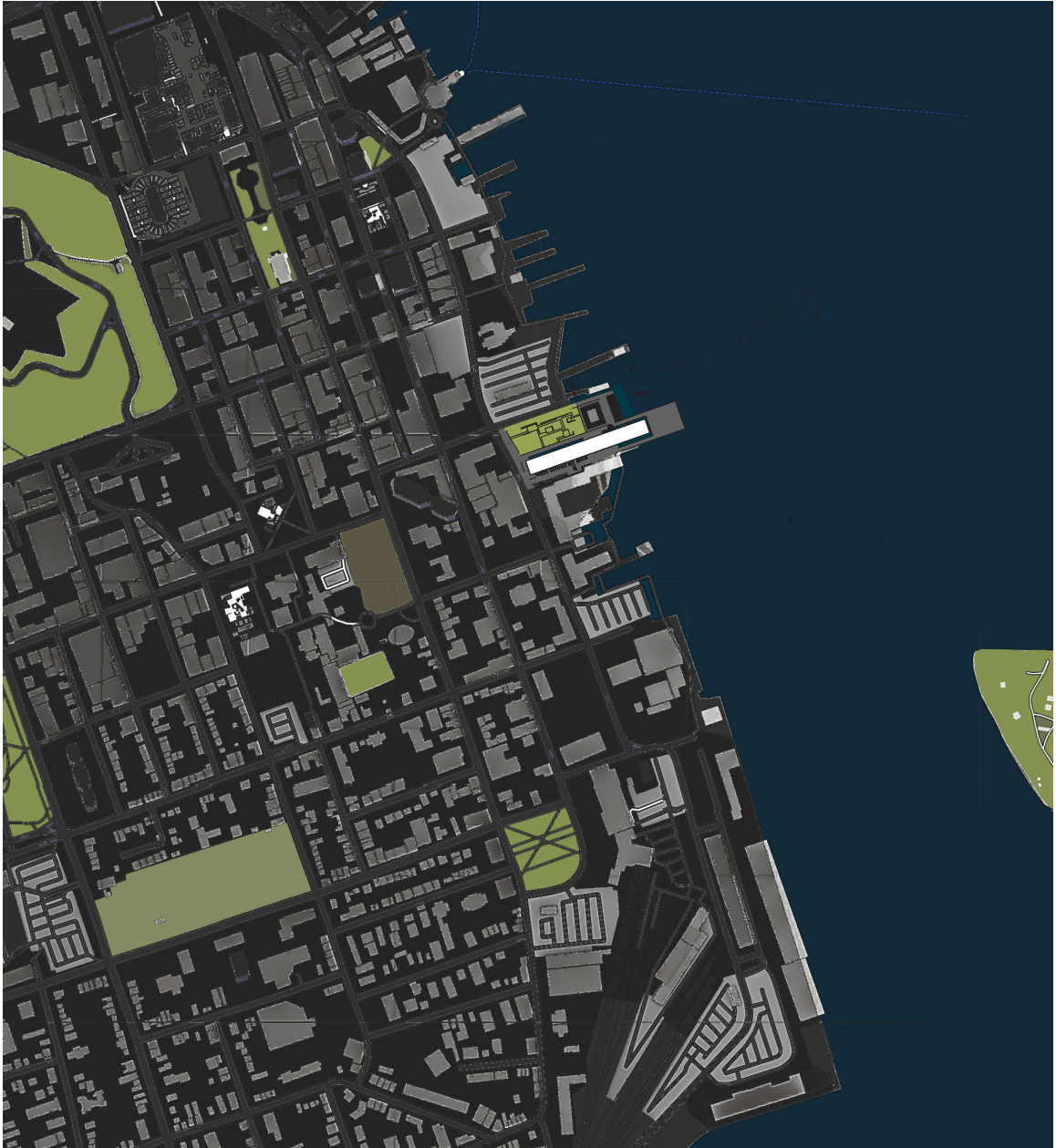

Diagram outlining current voids due to large expanses of surface parking on the harbourfront; base map from GIS



Map showing the new AGNS positioned at the location of first settlement, and nucleus of the city; base map from Google and GIS.



50

200

500M

Map showing the new AGNS, A Museum by the water, in a park, at the centre;  
base map from Google.



The Halifax harbourfront is an integral part of the culture, history, economy and social aspects of the city. As a central hub to Atlantic Canada and one of the busiest ports, Halifax draws as many as 10,000 tourists per day during peak season. In recent years, the Halifax waterfront has benefited from many mixed-use development projects; even so, the city still has a relatively barren waterfront, adorned with blocks of surface parking.

### Waterfront Evolution

During the age of sail, Halifax's waterfront was densely populated with a series of finger piers and adjoining warehouses, at one time, the shoreline boasted over 180 piers. Now, the shift from schooners to modern shipping containers streamlined port activities to two segregated ports at the southern and northern tip of the city.

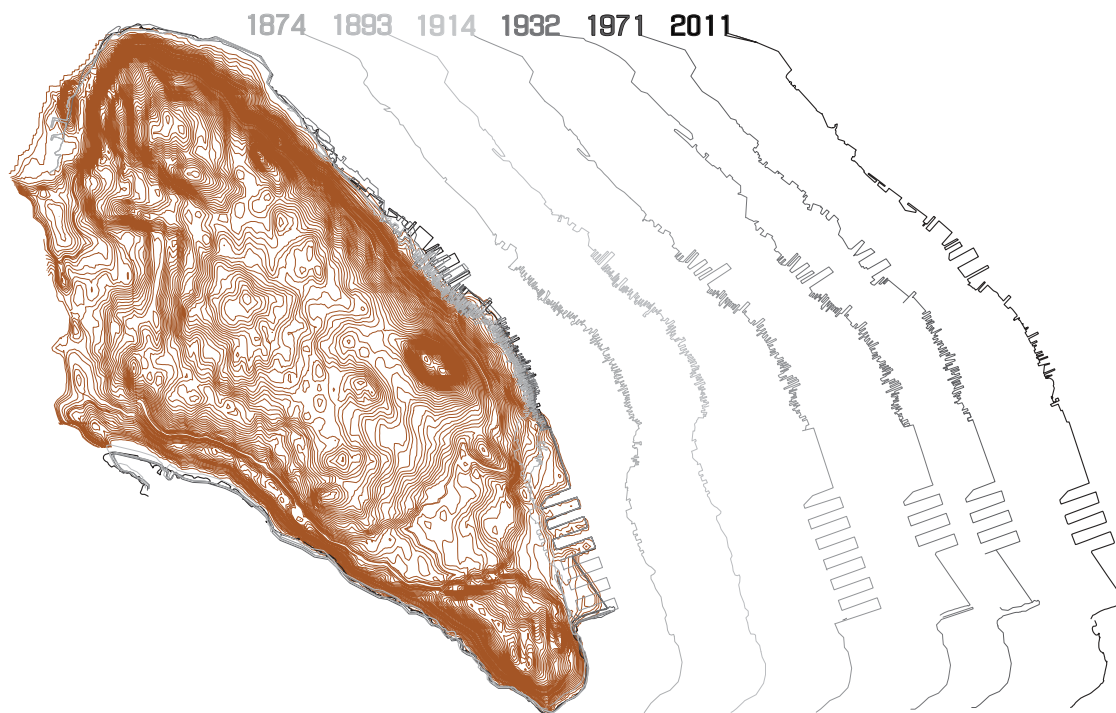

Diagram showing the waterfront evolution. Through time, the border oscillates, the waters edge morphs in tandem with the needs of the city; base map from The Nova Scotia Archives and GIS.

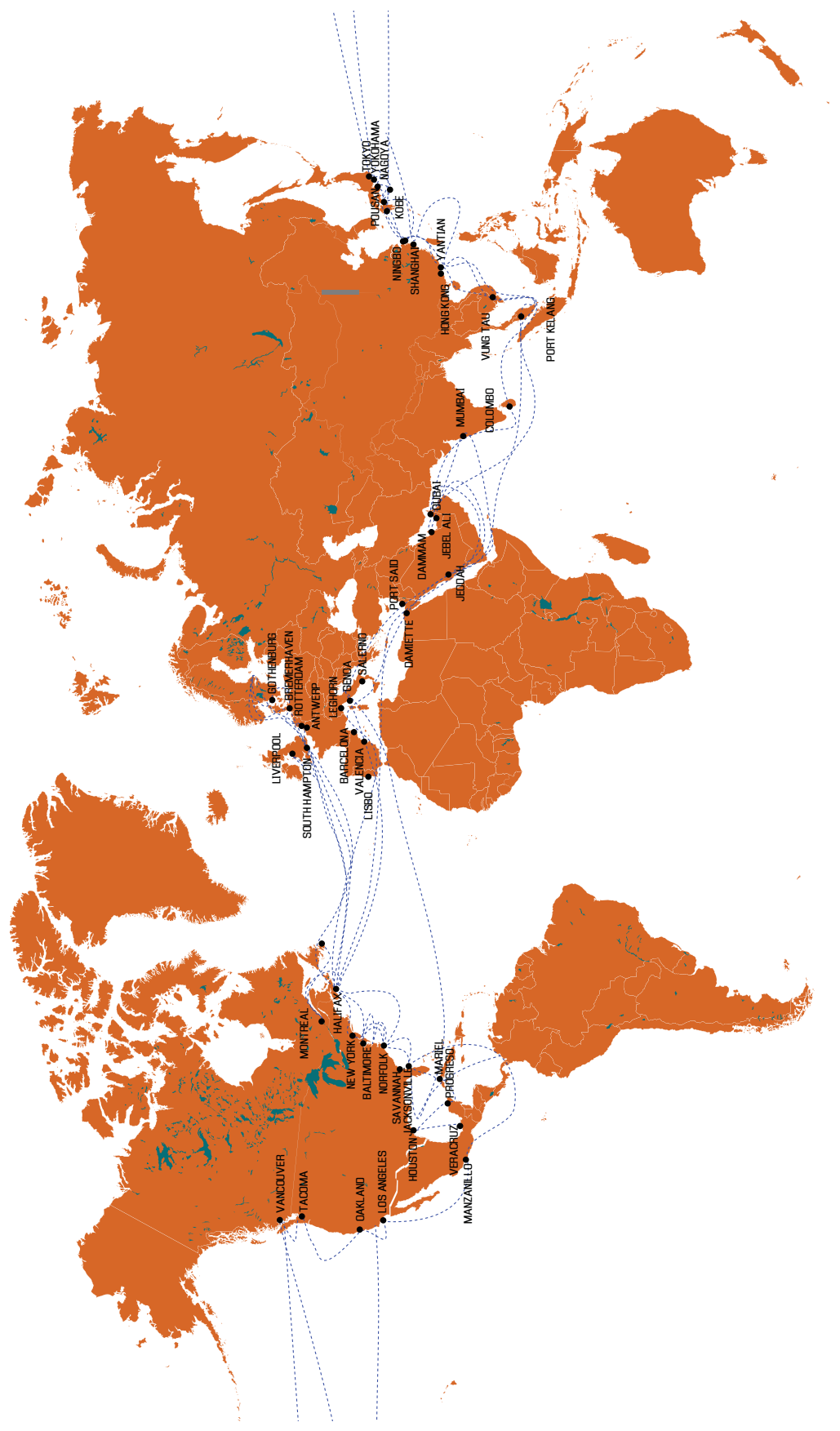

Diagram showing international connection to the Halifax harbour; base map from the Freepik and shipping data from the Port of Halifax.

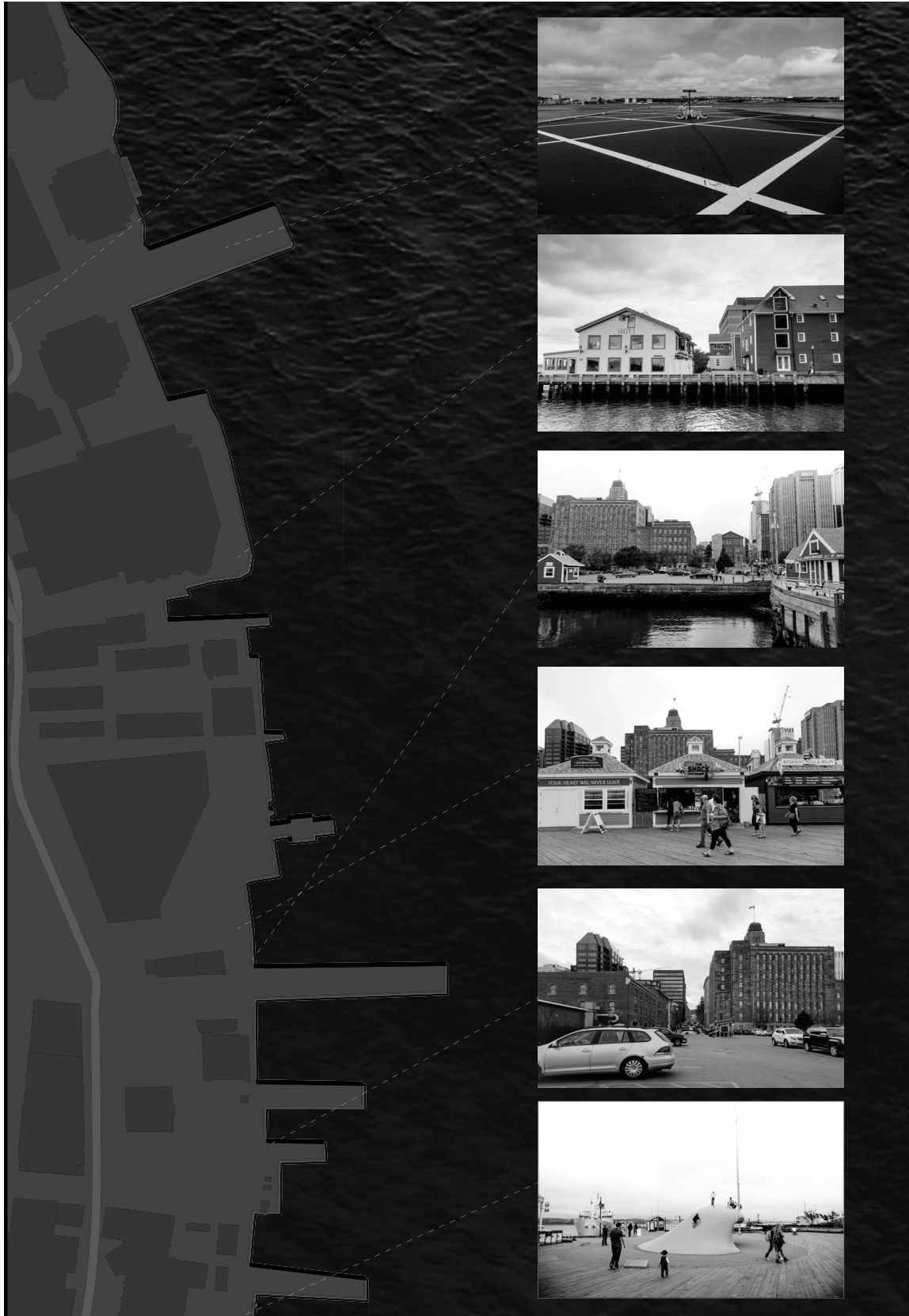

Photo assemblage of the harbourfront. Images are from the viewpoint of boardwalk to harbour, and boardwalk to city; base map from GIS.

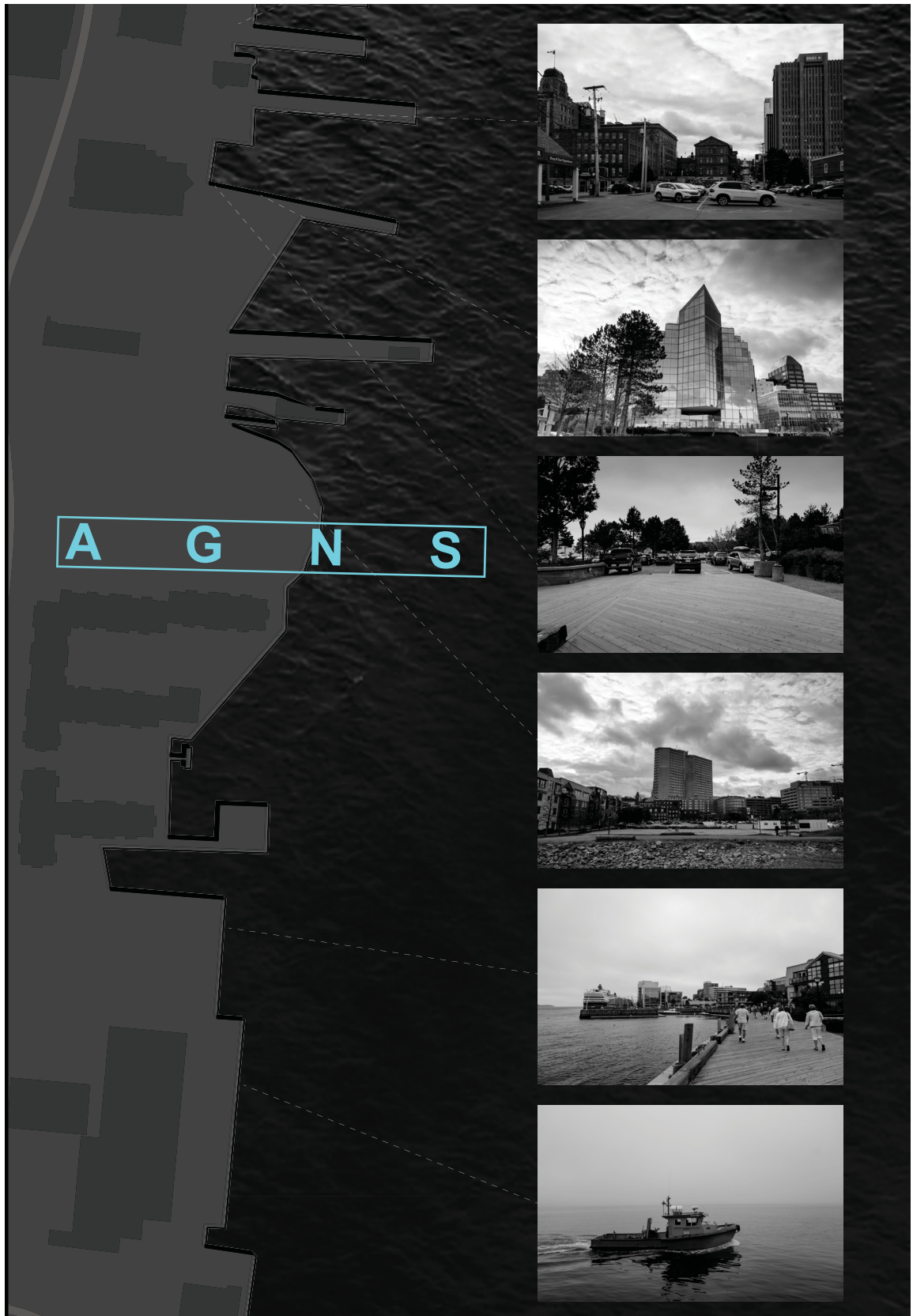

Photo assemblage of the harbourfront continued; base map from GIS.

## CHAPTER 3: DESIGN

### Site Strategies

**GUGGENHEIM**  
BILBAO, SPAIN



**THE MENIL**  
HOUSTON, USA

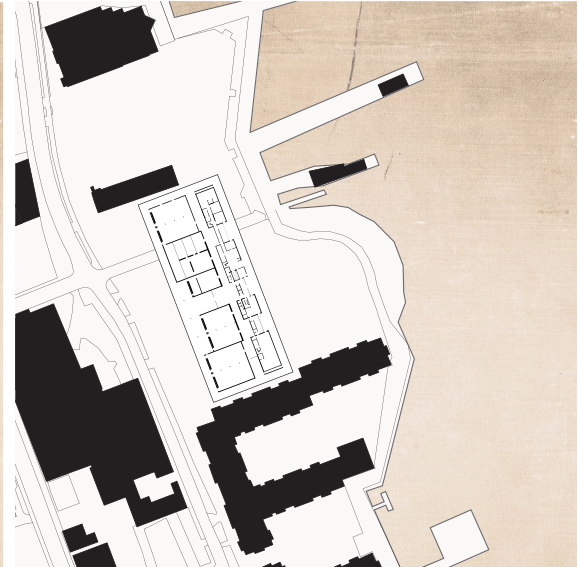

**THE NEW MUSEUM**  
NY, USA

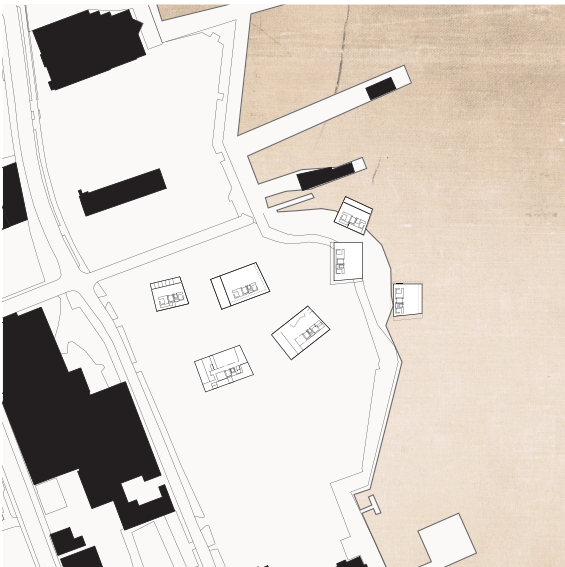

**DENVER ART MUSEUM**  
DENVER, USA

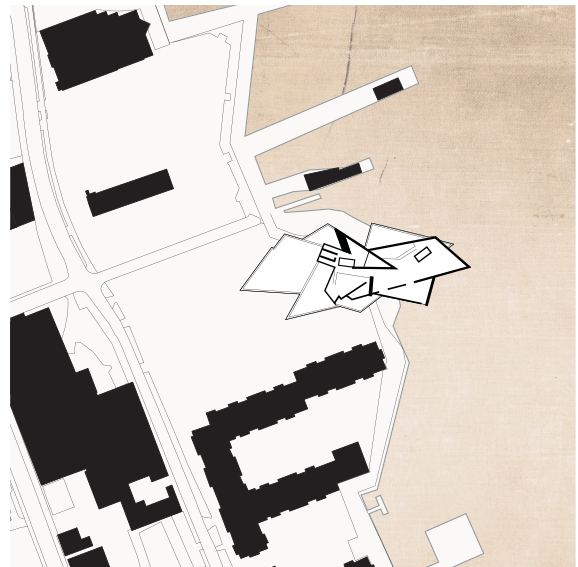

25 100 400M 

Series of diagrams exploring site strategies through the use of notable art museums and galleries; base map from GIS.

**ICA**  
BOSTON, USA

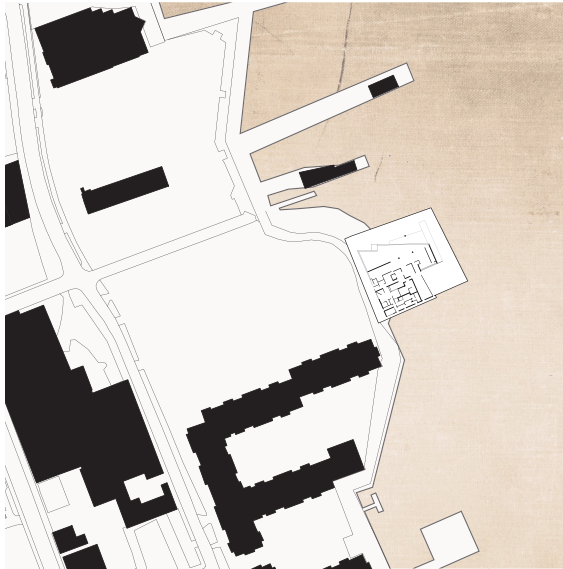

**THE MODERN**  
FORT WORTH, TX

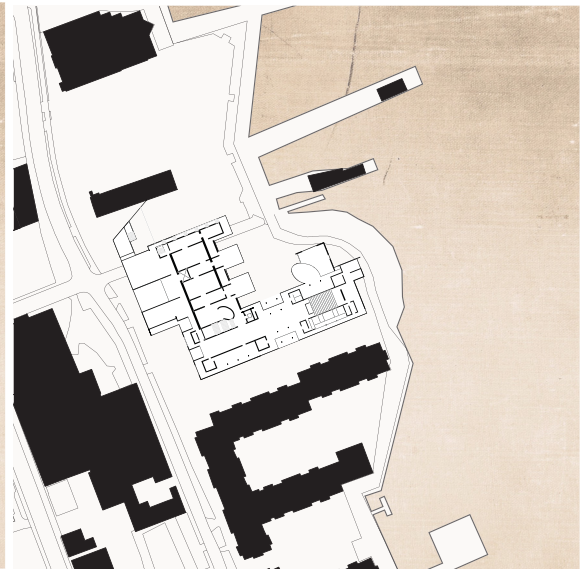

**CAM**  
CINCINNATI, USA

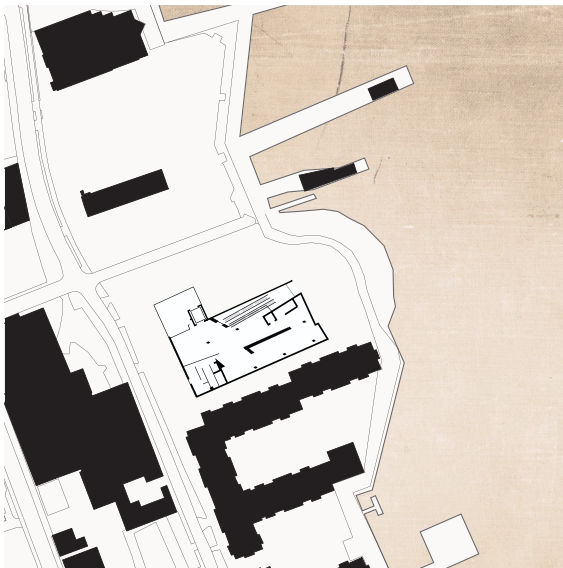

**THE NELSON ATKINS MUSEUM**  
KANSAS CITY, USA

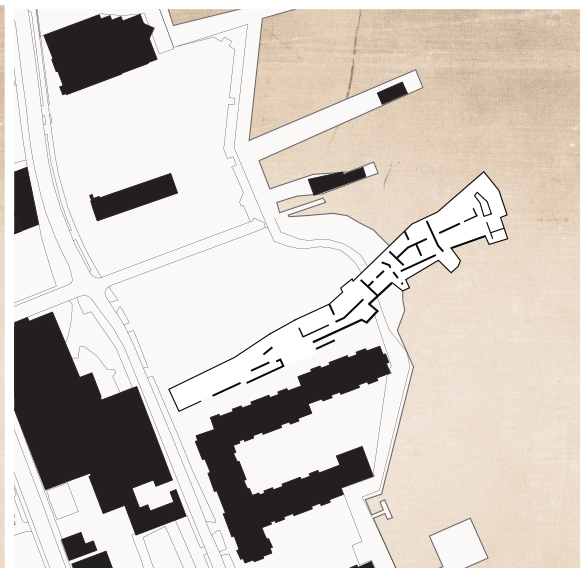

Site strategies continued; base map from GIS.

## Lighting Strategies

The use of daylight in an Art museum is often discouraged as a result of its destructive potential to the artwork. Throughout history, architects have made many attempts to eliminate those destructive qualities, while keeping the desirable affects it produces for the viewing environment. It is generally assumed that if natural light is used, it should be diffused and a reduction in ultraviolet rays is paramount. It is also important to note that the larger the light-emitting surface area relative to the viewing area, the softer the light will be.

In this image highlights an investigation into the potential for using canvas as a diffused lighting source for the Art Gallery of Nova Scotia's prized possession, the Maud Lewis house. The piece is currently tightly cramped in a dimly lit space binging light into the space sets it free from its current constrained position, and situates it into an environment similar to it's original location.

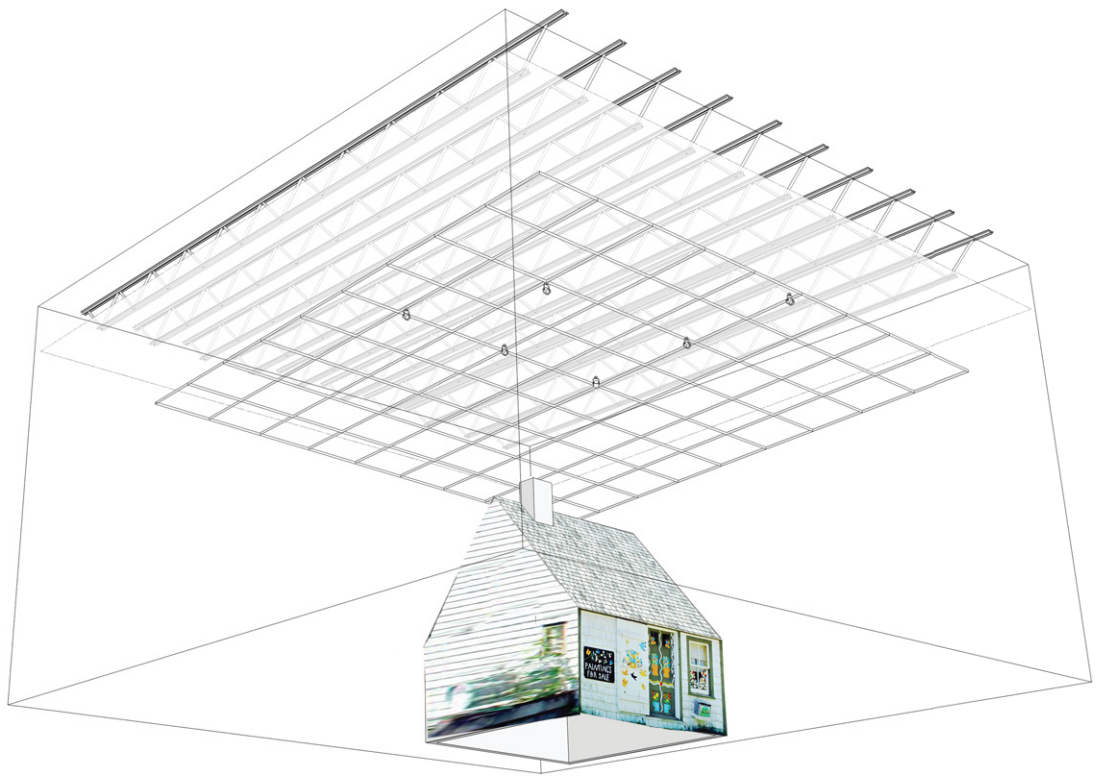

Diagram showing different layers of opacity above the Maud Lewis gallery.



Model study looking at light and opacity. Materials: Sail canvas and wood.



Early rendering looking at ways of illuminating the waterfront with light walls, providing both 24 hour security lighting and exterior exhibition space.



## Design Sequence

### Site context

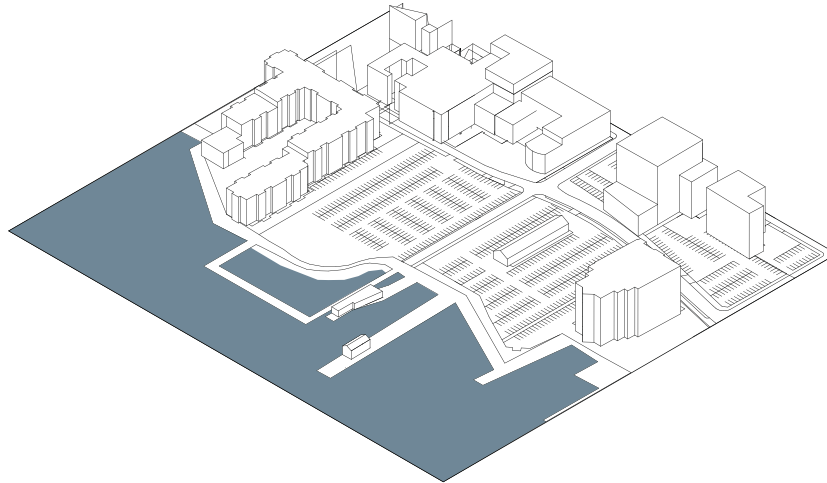

Diagram showing the expansive parking lot along the harbourfront.

### Site Parameters

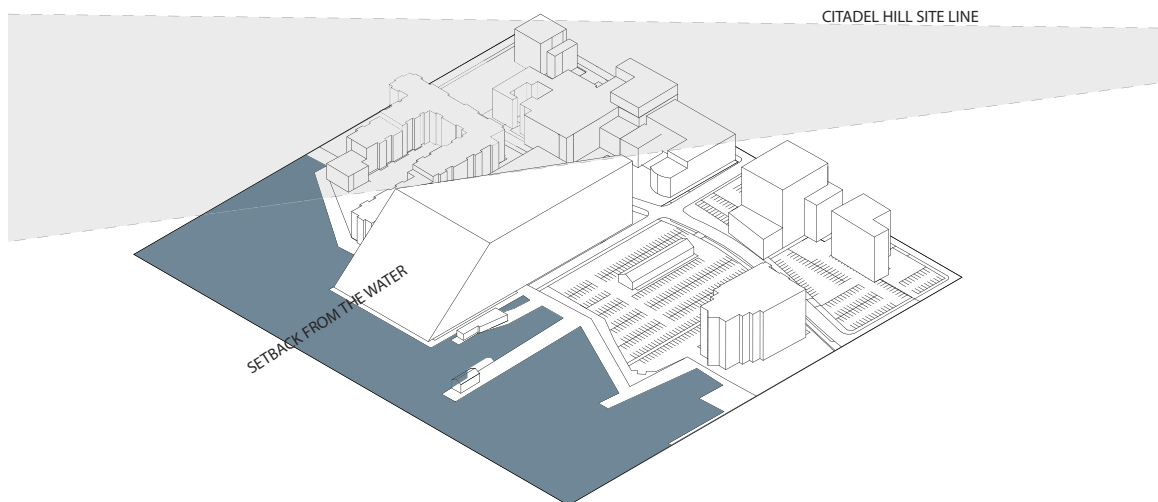

Diagram showing site restrictions

## Contemporary Harbourfront Building Typology

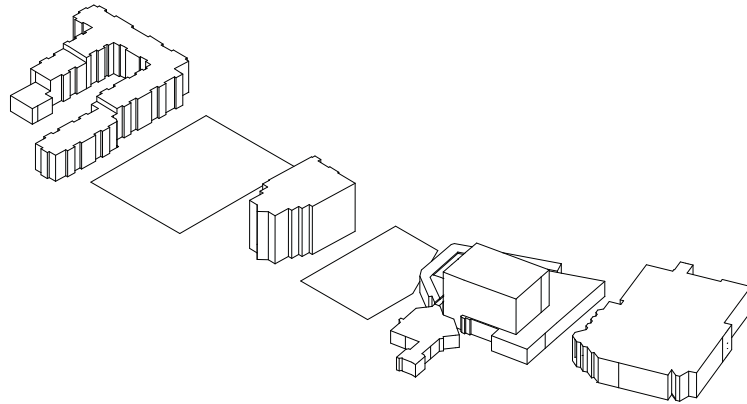

Diagram showing typical structures along the harbourfront.

## Historical Connection to the Harbour

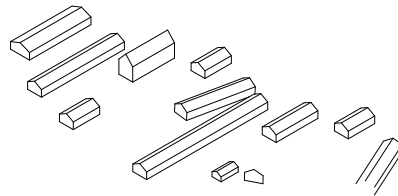

Diagram showing historical structures along the harbourfront.

## Re-establishing the Historical Harbourfront

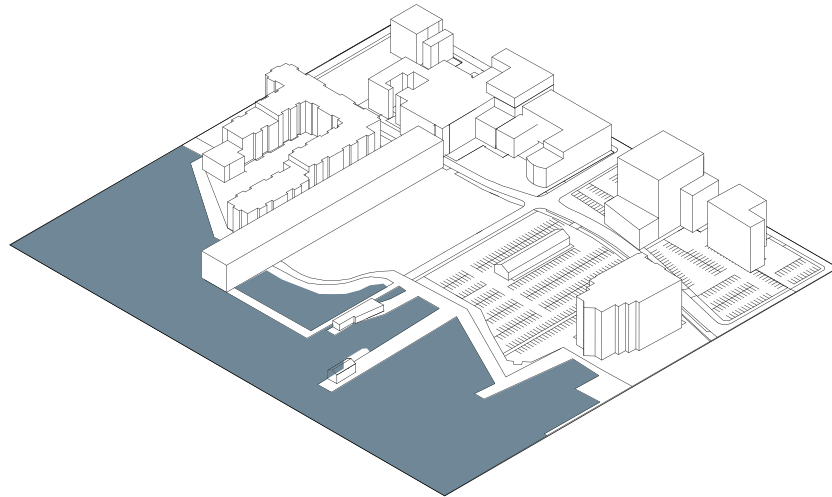

Diagram showing the new AGNS re-establishing the connection to the harbourfront.

## Lifting the Building

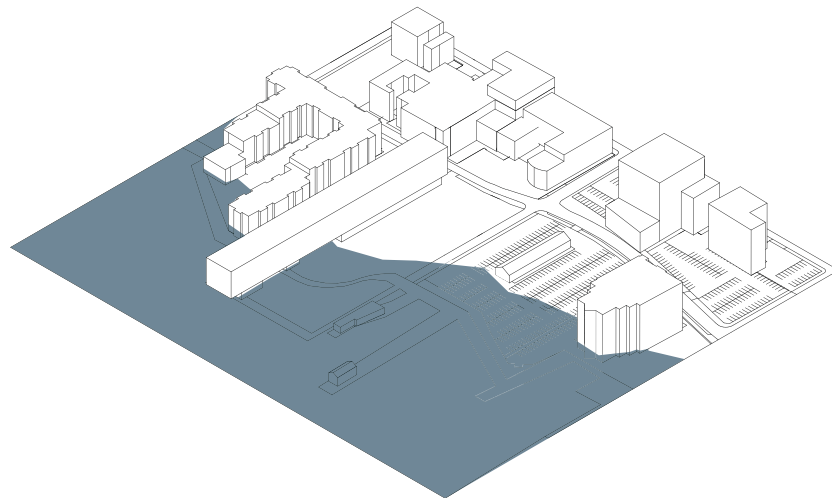

Diagram showing the AGNS lifted up to ensure protection from the 100 year high water mark and to provide uninhibited flow on the boardwalk.

## Elevating the Art

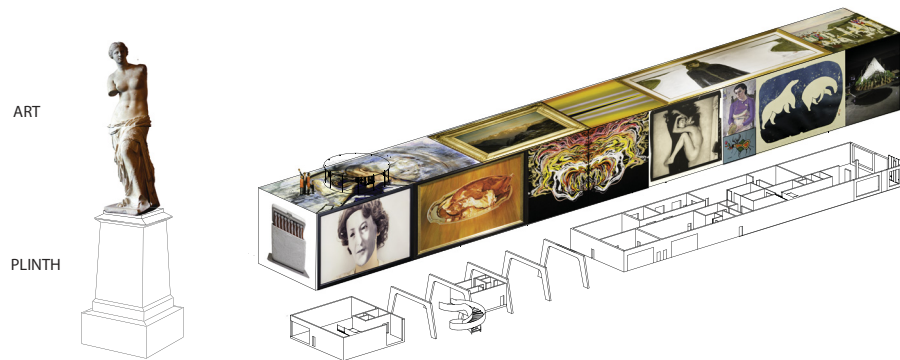

Diagram showing artwork elevated on a plinth

## Extending the Boardwalk

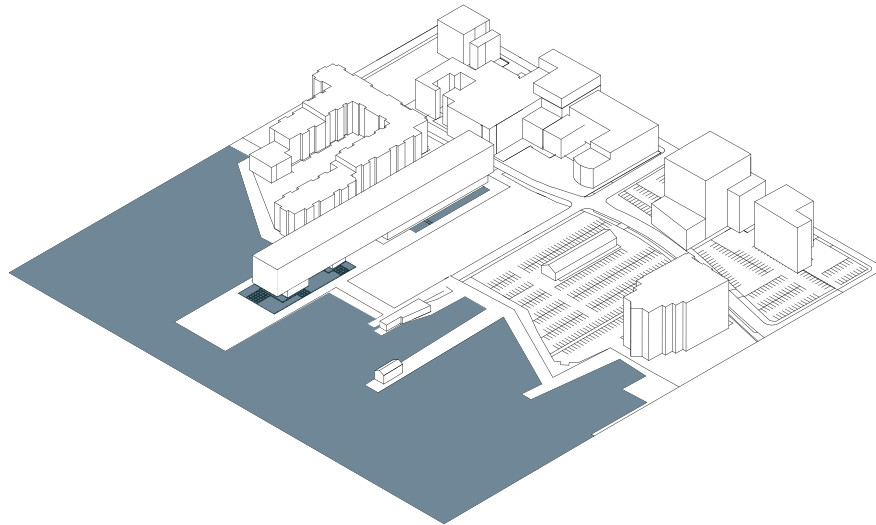

Diagram showing the boardwalk extended to the water.

## City Gallery

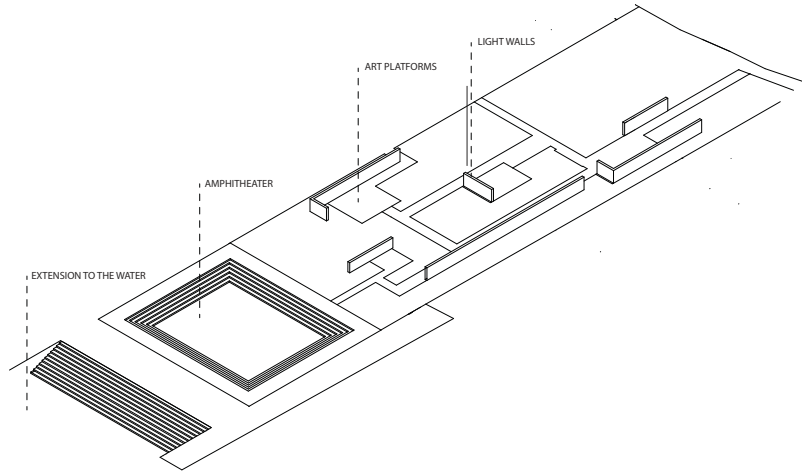

Diagram showing the extension of gallery spaces into the city.

## Merging the Boardwalk with Building Circulation

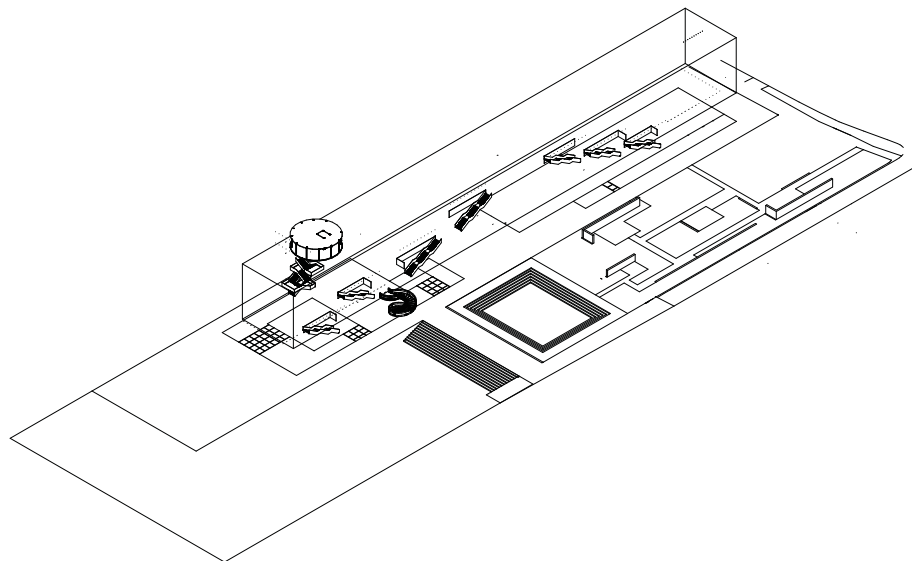

Diagram showing the extension of the boardwalk through the building on the north side.

## Introduction of the Service Core

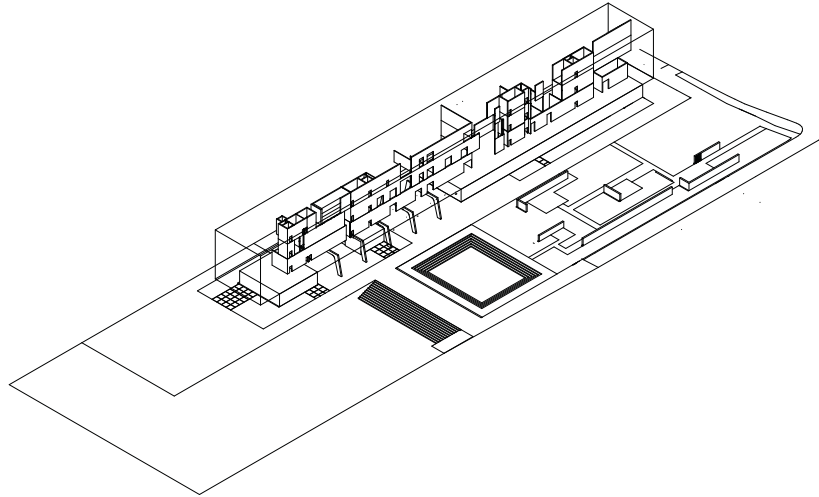

Diagram showing the main service core providing diffused northern light into the galleries.

## Facade Elements

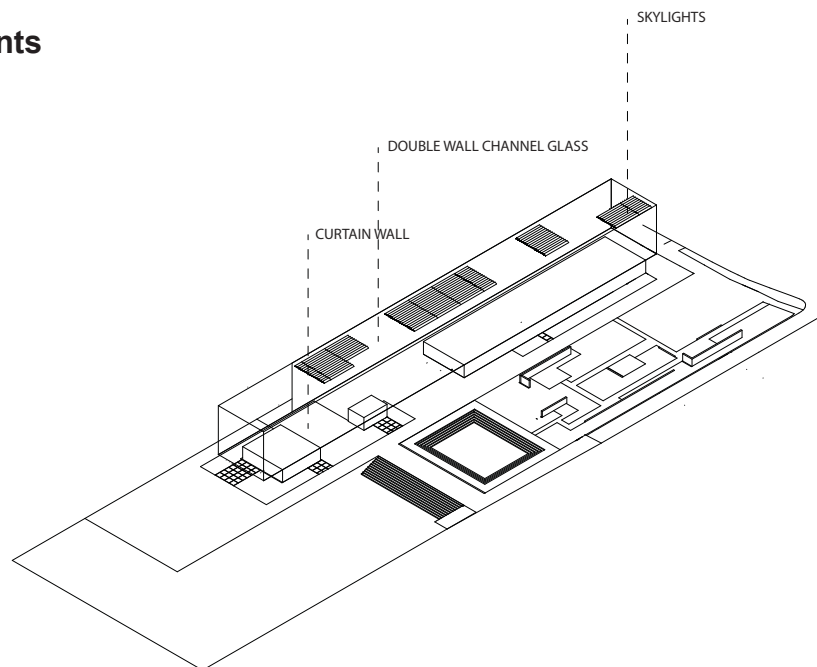

Diagram showing the facade elements

Situ:

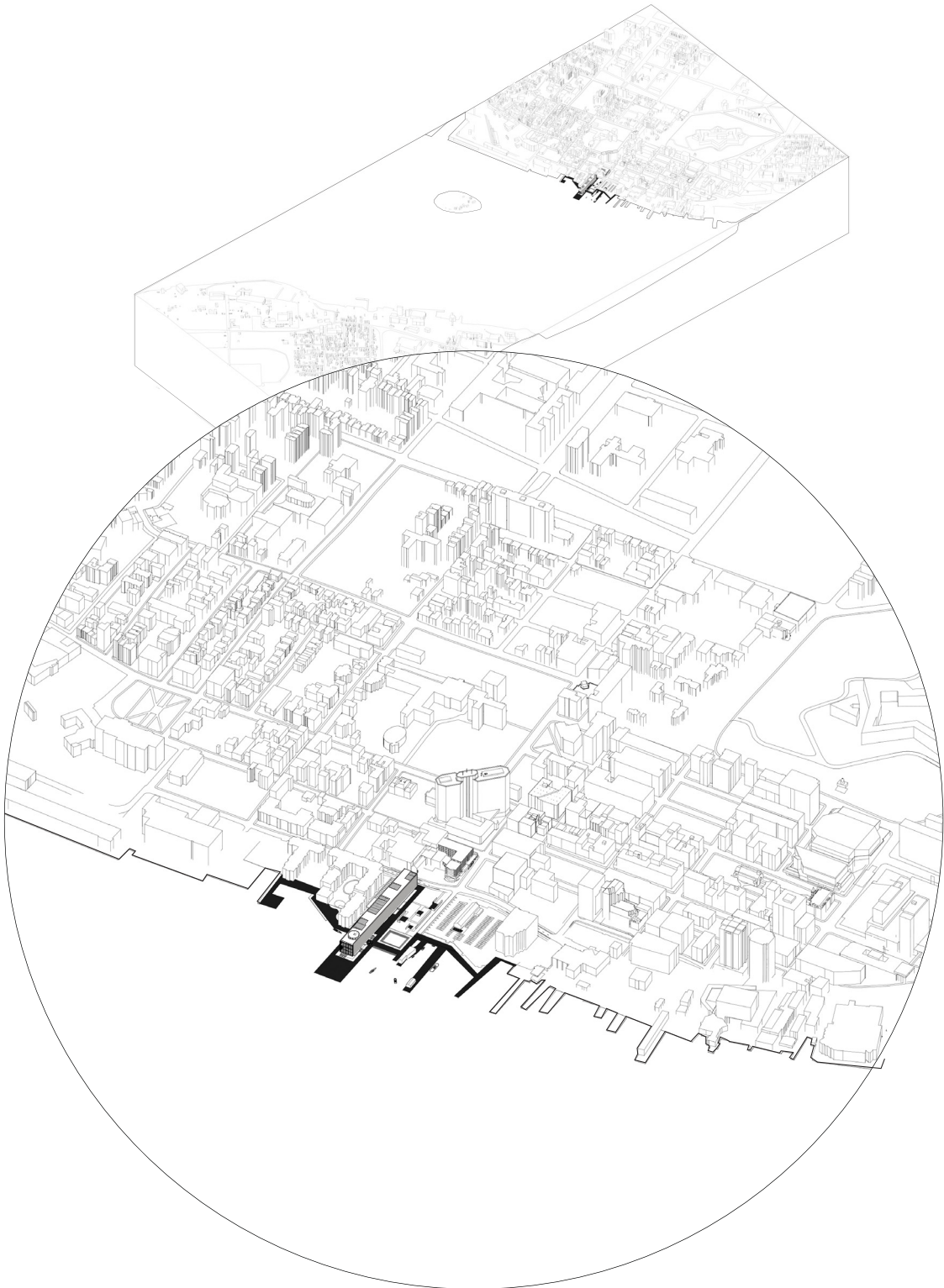

Diagram showing the AGNS at the centre of the boardwalk and the city; base map from GIS and Google.

## Program

	ART	SERVICES
ROOF	<p>Circulation Rooftop Gallery Void</p>	
LEVEL 3	<p>Circulation New Media Gallery Itinerent Gallery harbourfront Gallery Children's Gallery Visible Storage Library Void</p>	<p>Mechanical Rooms Art Storage Curitorial Offices Director's Office Finance + Admin Support Staff Office Lounge Locker Room Kitchen</p>
LEVEL 2	<p>Circulation Folk Art Galleries Maud Lewis Gallery Laboratories [Canadian Art] Laboratories [Contemporary] Conservation Auditorium Lobby Void</p>	<p>Art Storage Control Room Theatre</p>
LEVEL 1	<p>Circulation City-view Gallery First Nations Galleries Anchor Galleries [Canadian Art] Laboratories [Contemporary] Art Storage Great Hall Bistro Void</p>	<p>Backstage Stage Storage Kitchen Food Storage Furniture Storage</p>
LEVEL 0	<p>Circulation Boardwalk Galleries Artist In Residence Amphitheater Boardwalk Gallery Green Space Underbelly Entrance Lobby Gallery Shop Cafe Info/Tickets Coat Check Workshop Wet Lab Ticket Booth</p>	<p>Loading Docks Wherehouse Isolation Room Garbage Disposal Mechanical Units Security Photo Studio Storage Mechanical Units</p>

Spatial distribution for program diagram.



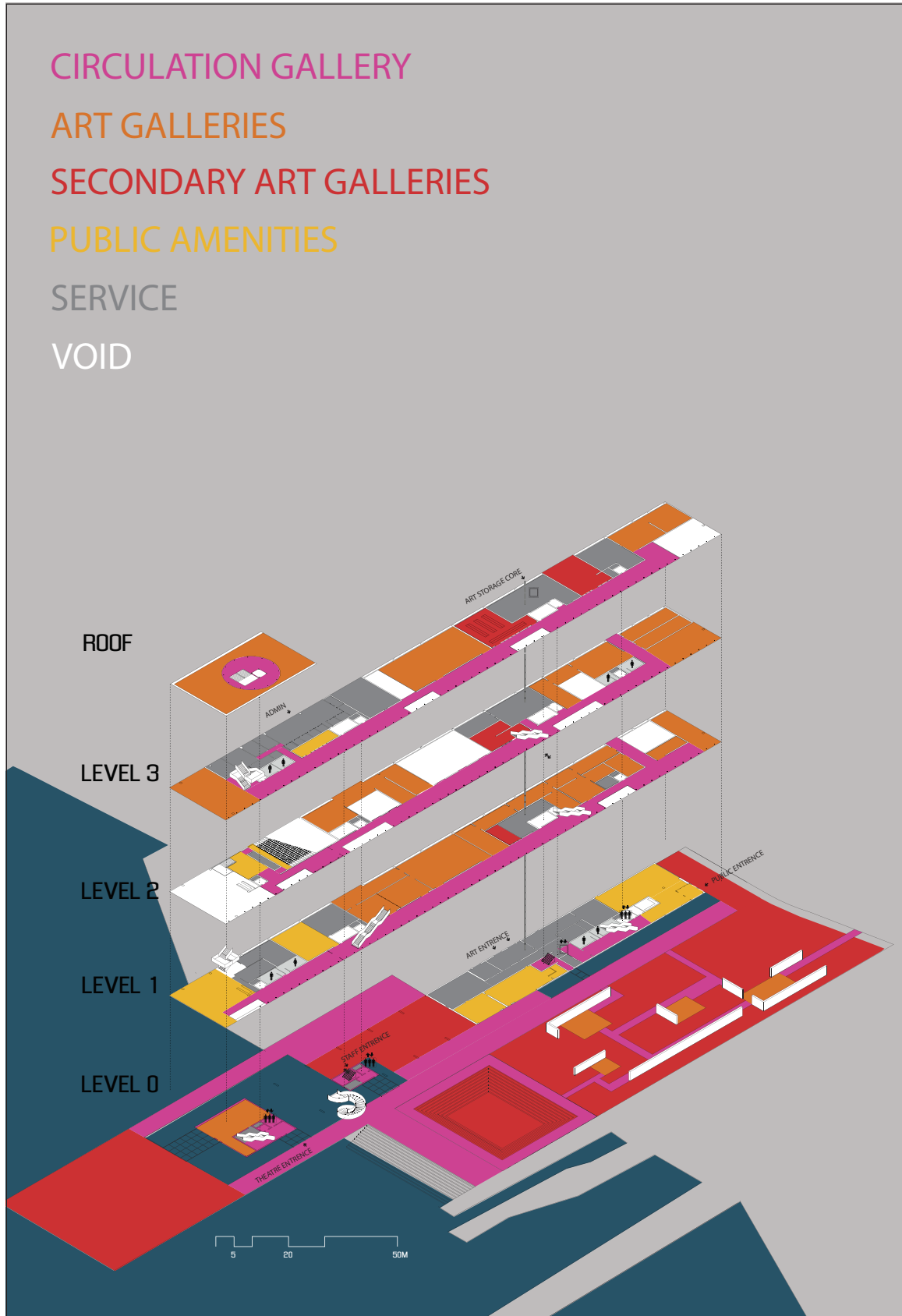

Program diagram showing spatial distribution, circulation, and access and egress

## Achieving Productive Tension

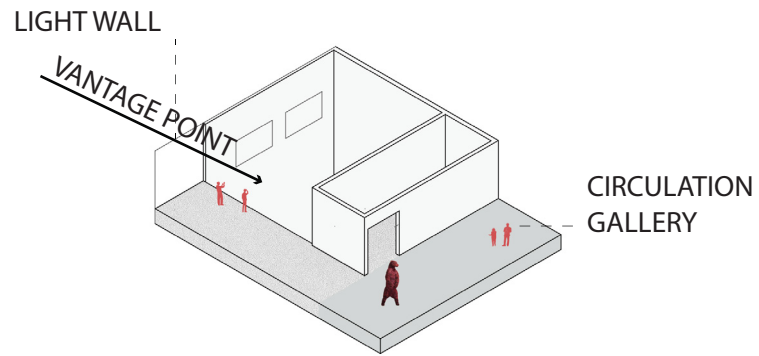

VIEW TO LOUNGE GALLERY BELLOW  
LEVELS 0 AND 1

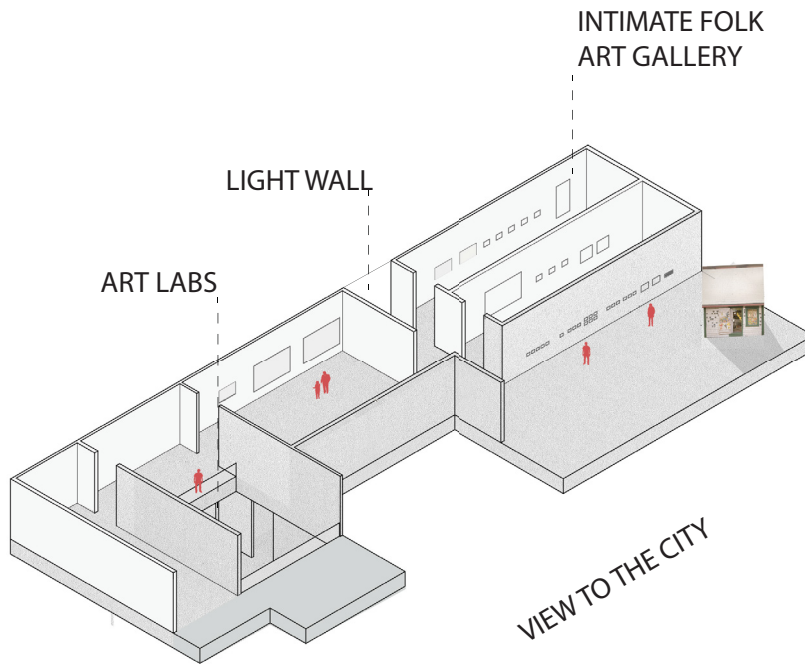

FOLK AND FIRST NATIONS ART  
LEVEL 2

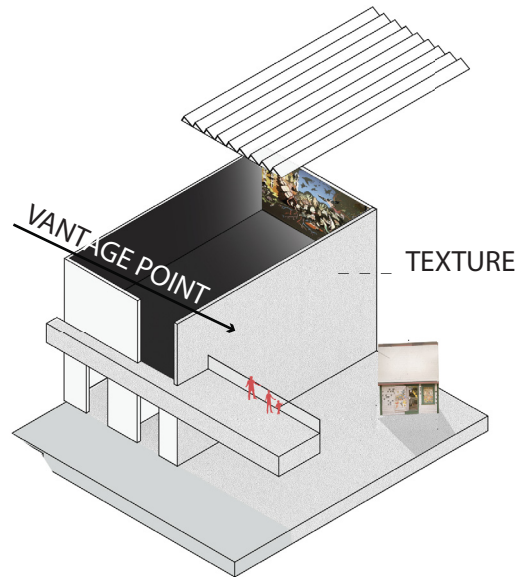

MOVING PICTURES  
VIEW TO MAUD LEWIS GALLERY BELOW  
LEVELS 2 AND 3

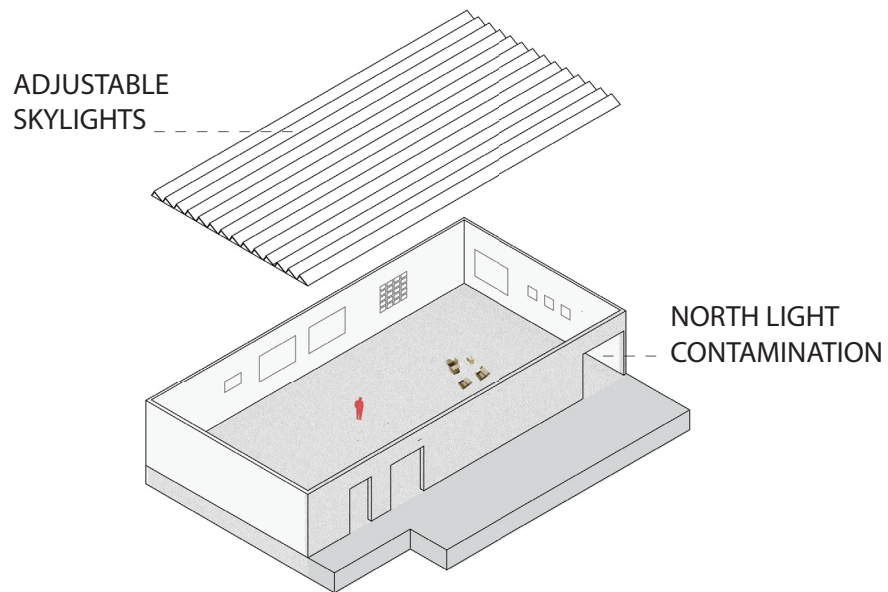

ITINERANT GALLERY  
LARGE EXPANSIVE SPACE FOR TRAVELING EXHIBITIONS

Achieving Productive Tension

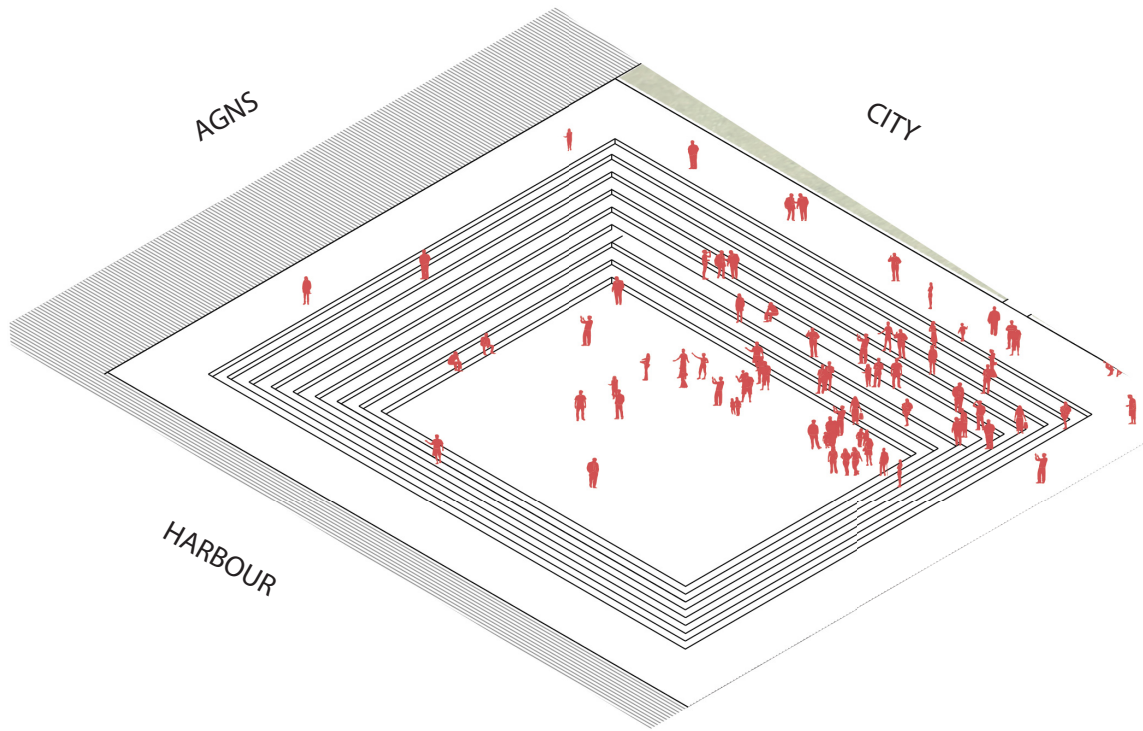

OUTDOOR AMPHITHEATER

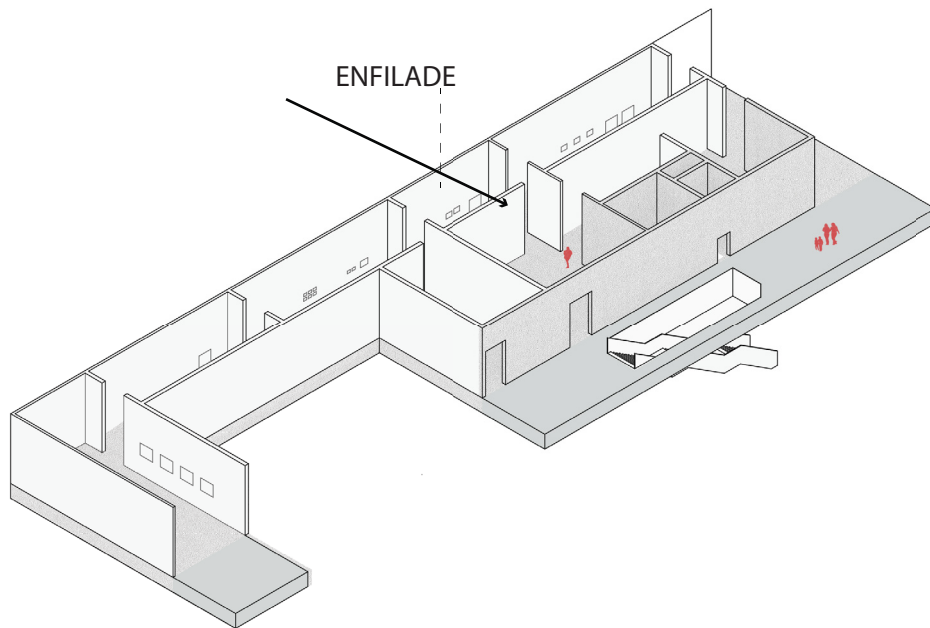

ENFILADE/ANCHOR GALLERIES  
INTIMATE CORRIDOR PROTECTING SENSITIVE WORKS  
FROM LIGHT CONTAMINATION  
LEVEL 2

Achieving Productive Tension

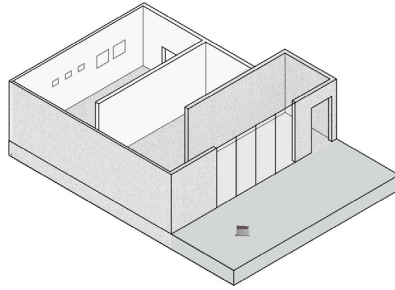

VISIBLE CONSERVATION  
LEVEL 2

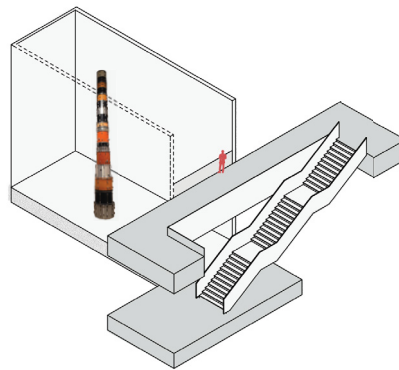

ART LAB - TALL AND LEAN  
LEVELS 2 AND 3

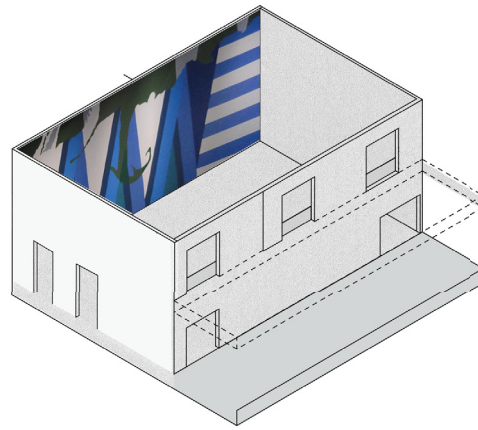

CARGO GALLERY  
LARGE DOUBLE HEIGHT SPACE  
LEVELS 1 AND 2

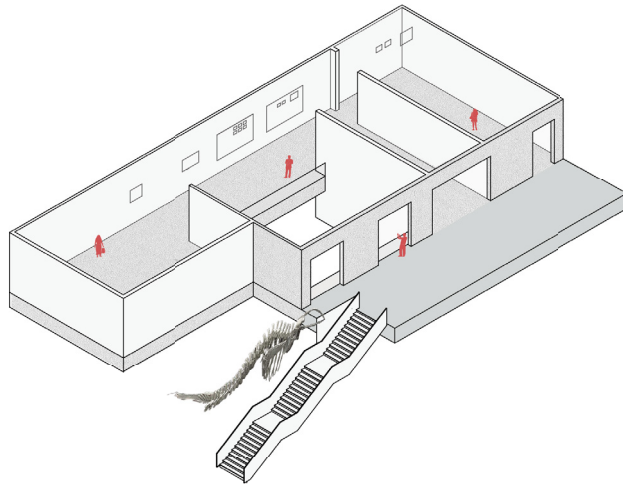

ART LAB 5 - CONTEMPORARY ART  
LEVELS 1 AND 2

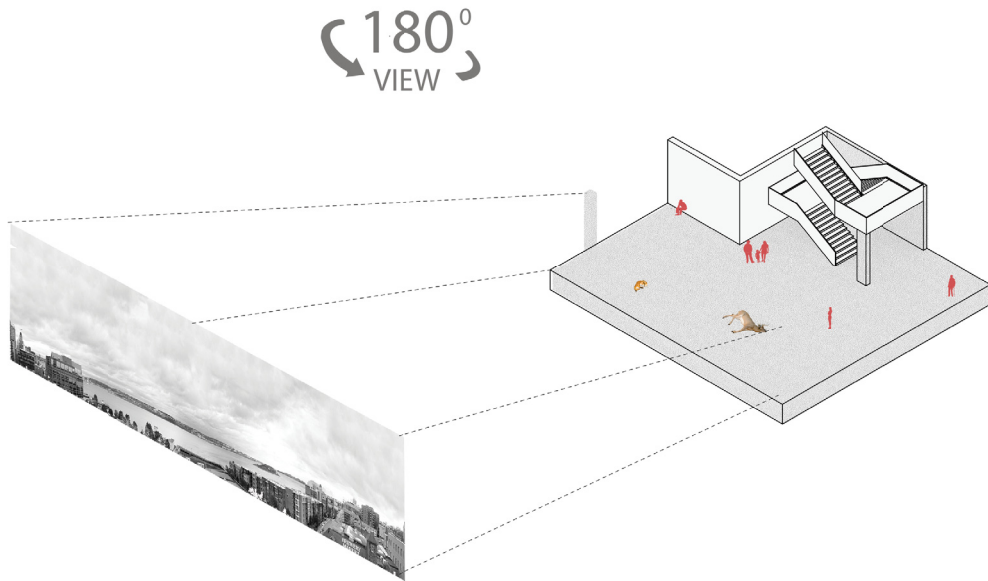

HARBOURFRONT GALLERY  
ACCESS TO THE ROOFTOP GALLERY  
LEVEL 3

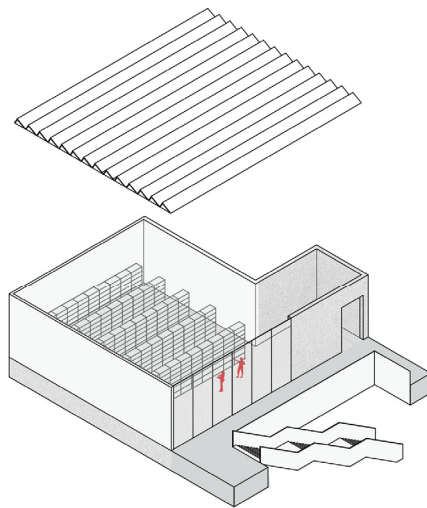

VISIBLE ART STORAGE  
LEVEL 3

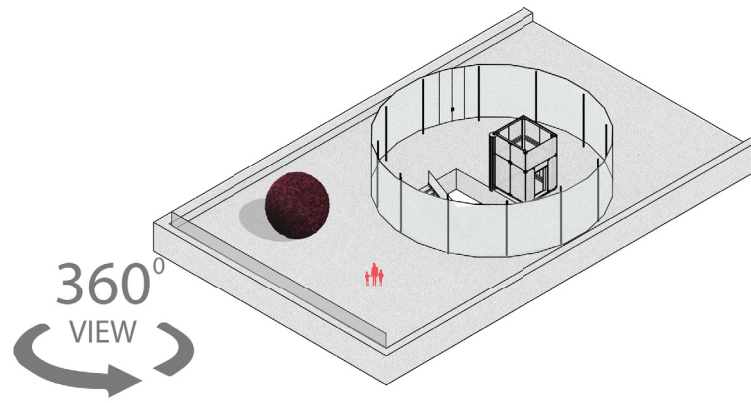

ROOFTOP GALLERY

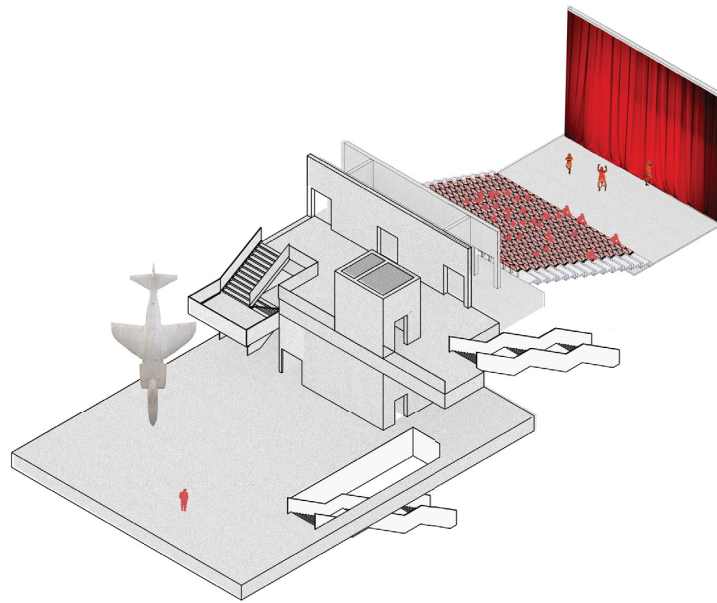

GREAT HALL AND THEATRE  
LEVELS 1 AND 2



CROSS-POLLINATION

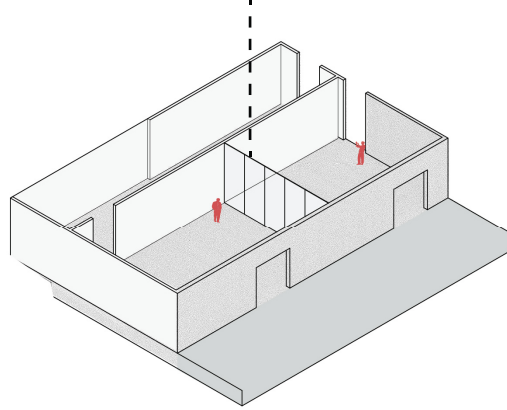

ART LABS

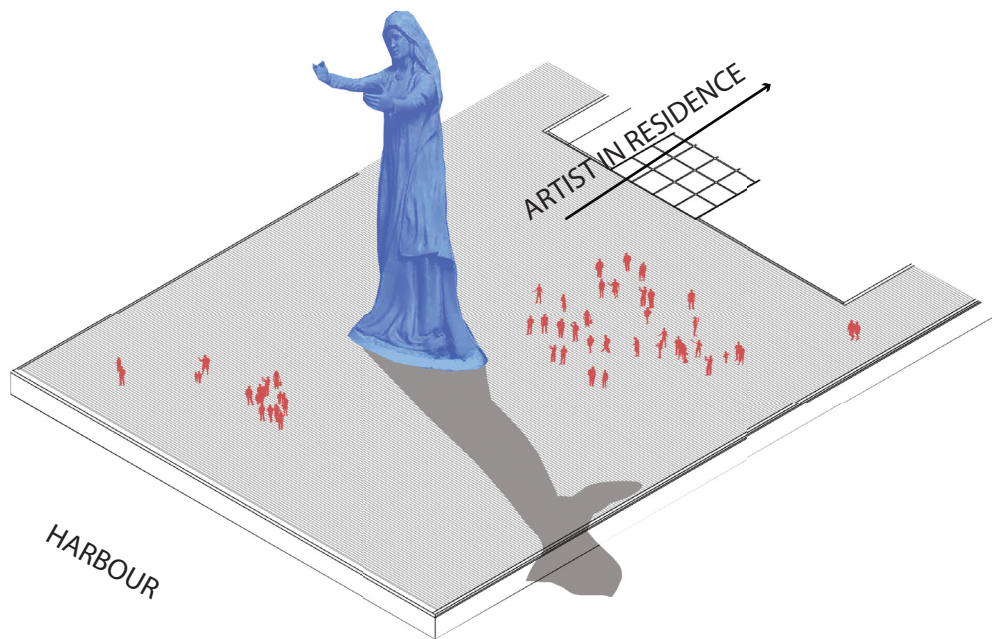

BOARDWALK GALLERY

Achieving Productive Tension

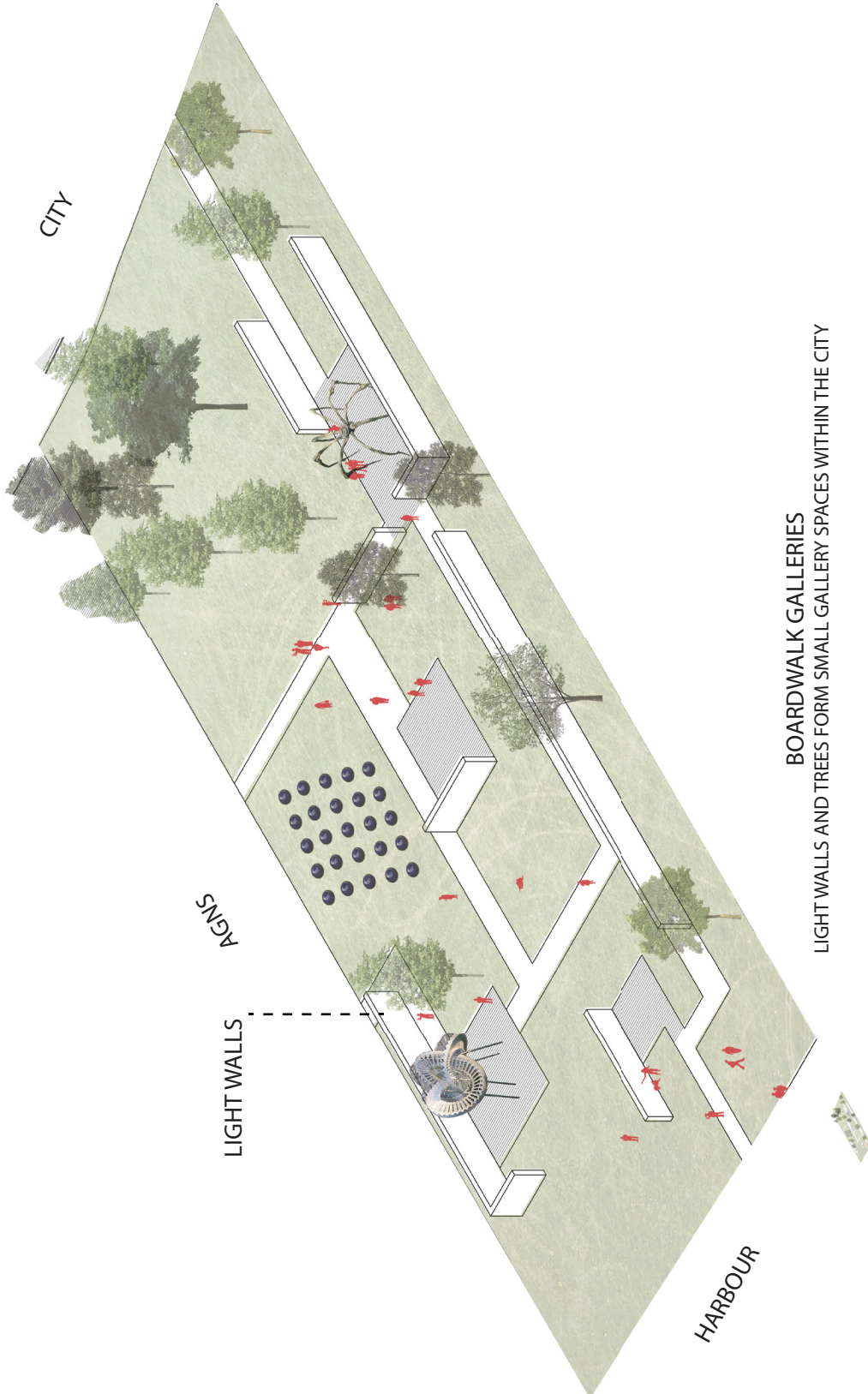

BOARDWALK GALLERIES  
LIGHT WALLS AND TREES FORM SMALL GALLERY SPACES WITHIN THE CITY

Achieving Productive Tension

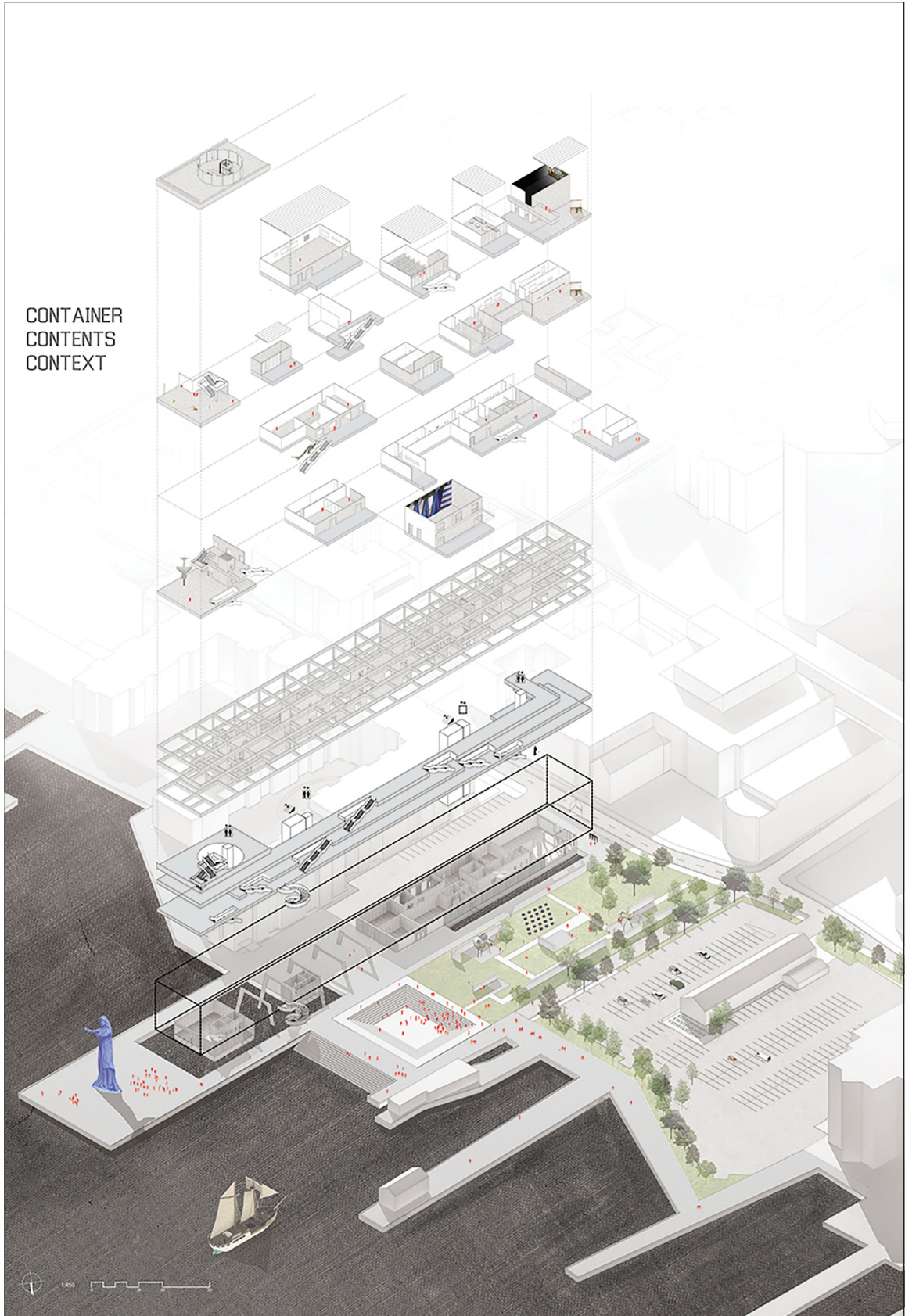

Axonometric showing the relationship between container, contents, and context.



Image looking down to the Maud Lewis House and out to the city.



Image of the 180 degree view from the Rooftop Gallery.



Image showing one of the Art Labs, where artists are encouraged to play with a variety of spatial consideration.

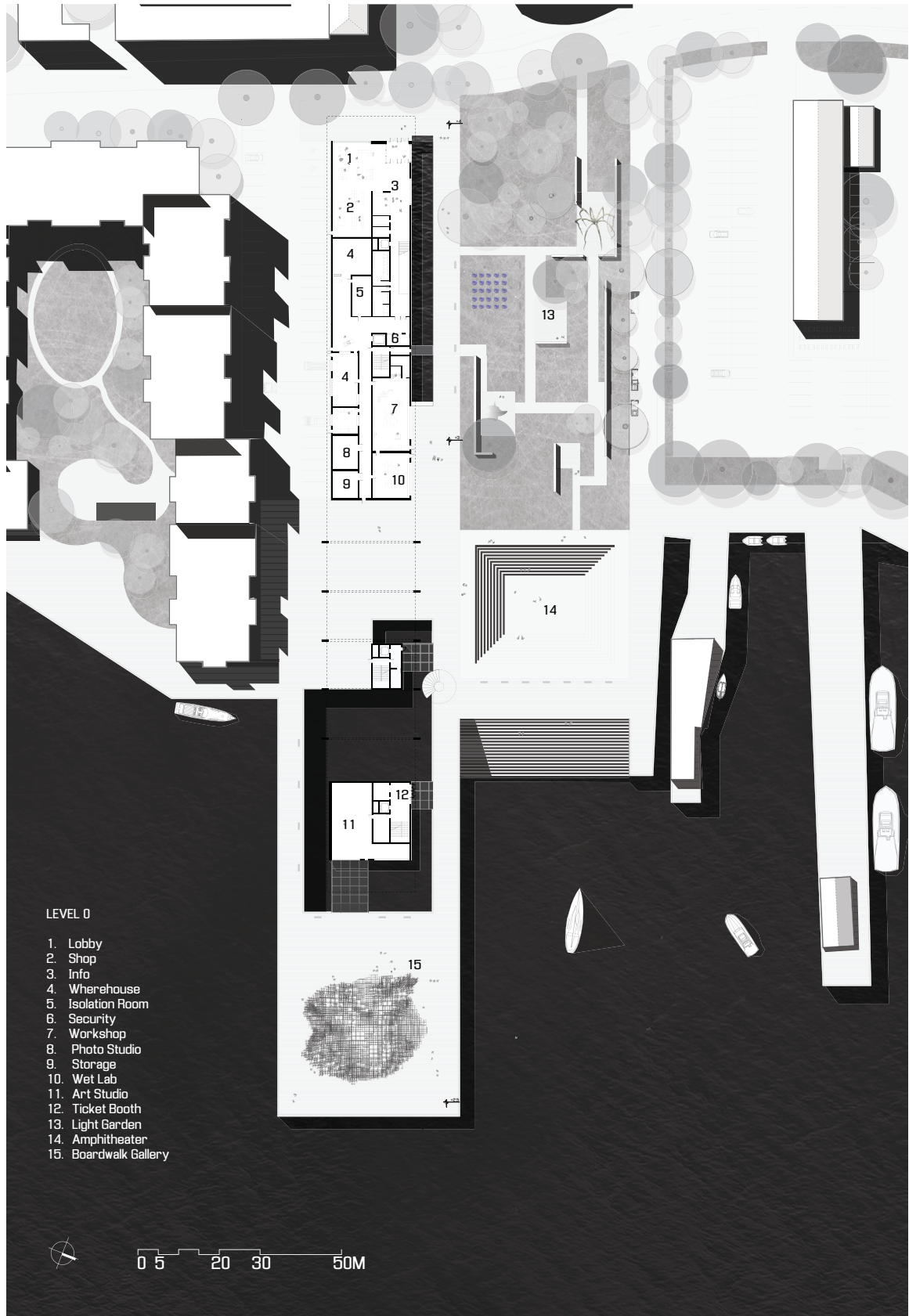

Level 0 Plan

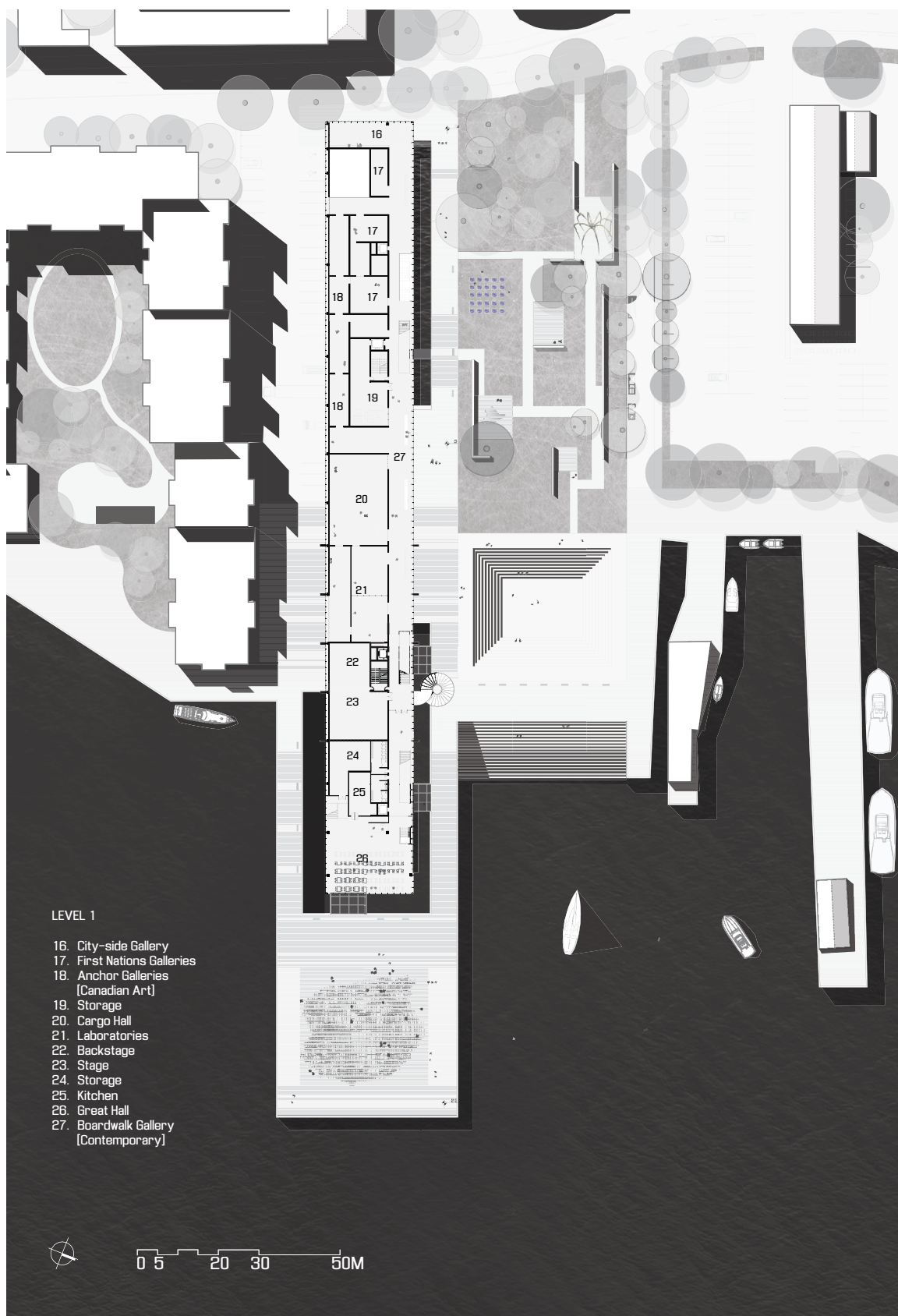

Level 1 plan



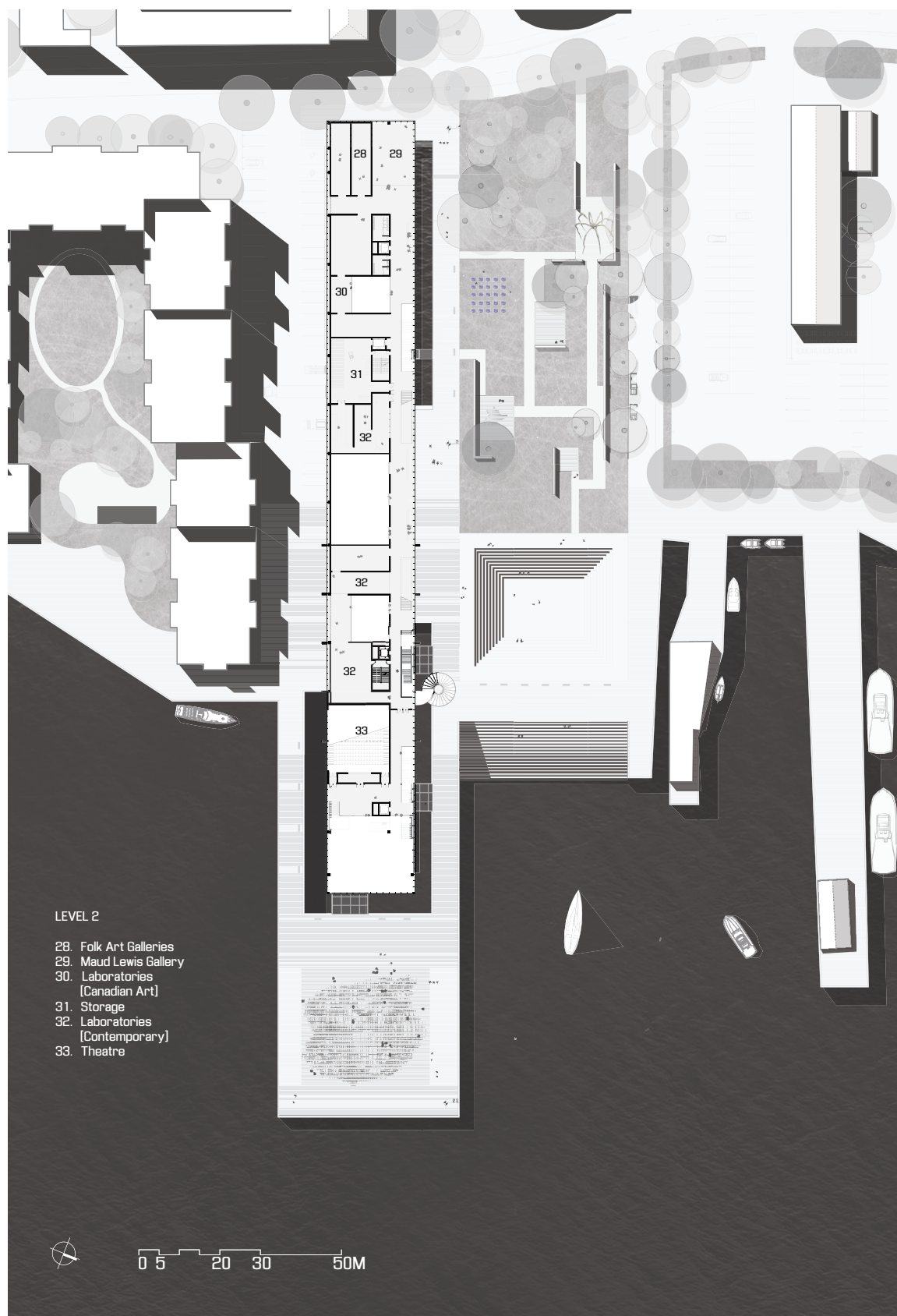

Level 2 plan

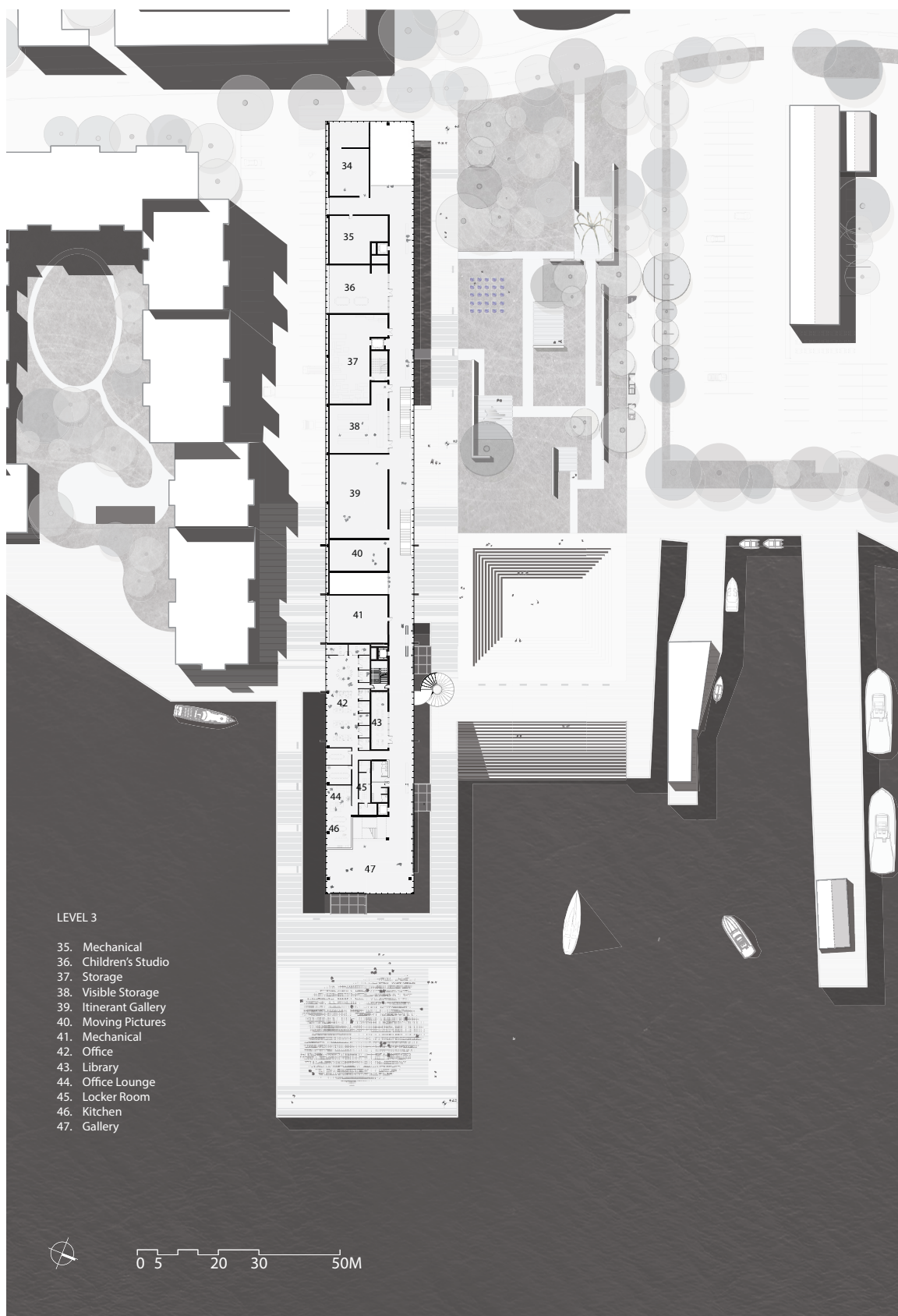

Level 3 Plan



North Elevation with city and harbour: Original drawing 100" X 30".



Detail: North Elevation



North Elevation

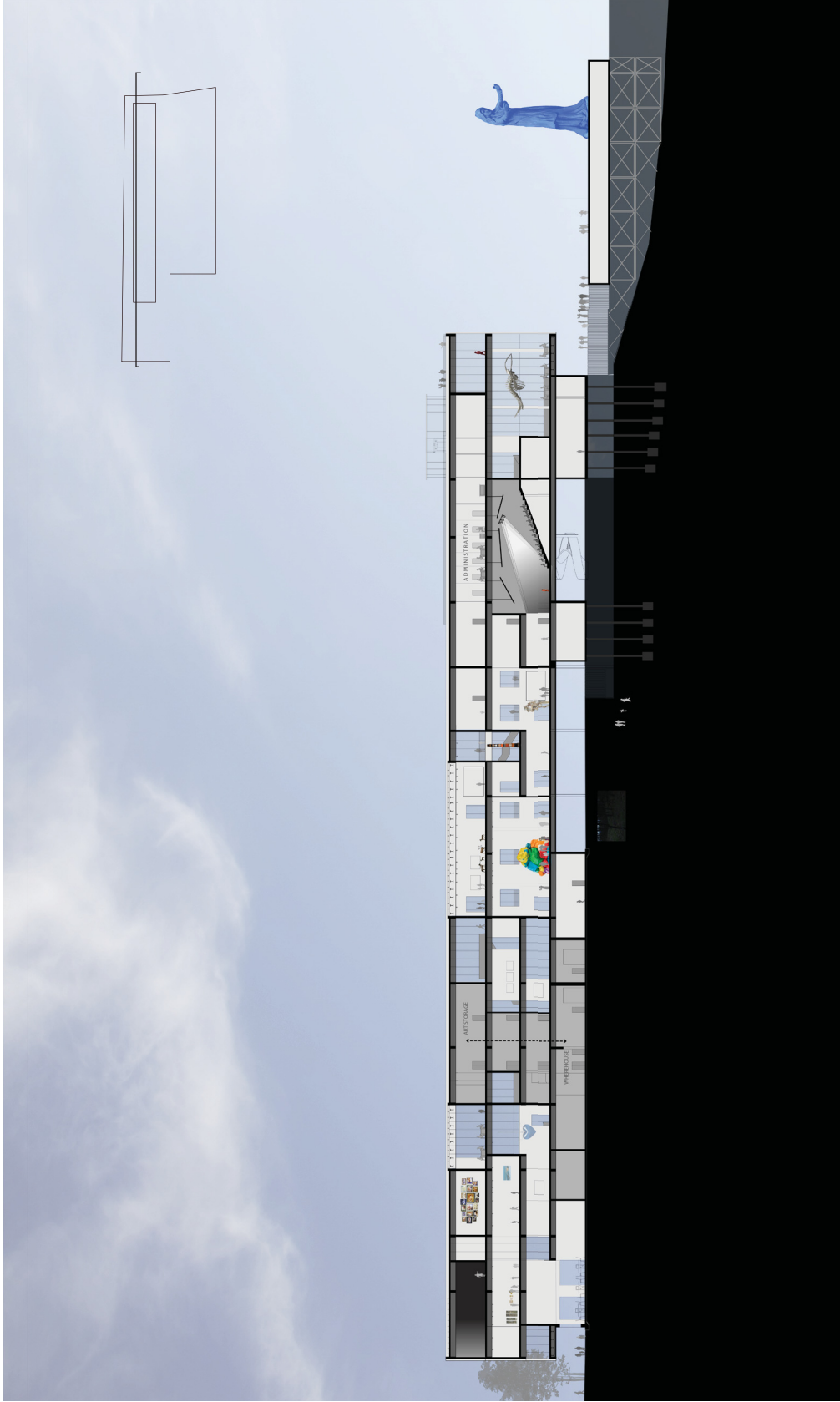

Section of the building from the perspective of the viewer looking out to the city at various moments throughout the building. As the viewer meanders throughout the gallery spaces, there is always a option of exiting to the circulation gallery. With uninterrupted views, the boardwalk gallery doubles as an enclosed vertical extension of the boardwalk, that takes you up to the top for 360 degree views of the city and harbour.



Section detail.



Cross section showing the building's face to the city. From Lower Water Street, the Art Gallery of Nova Scotia's lean profile, ensures minimal interruption to views of the water. At the human scale, the paths, light walls and trees, that make up the conglomerate of the boardwalk galleries, provides framing moments from the street.



The vertical circulation gallery extends from boardwalk and continues throughout the building. The variety of spatial configurations, designed with specific programmatic intent, are free to be used as curators and artists please. Depicted in the cross section, is the Maud Lewis gallery, a double height space with windows to the North and West, in conjunction with diffused light from above. On Level one, the cityside gallery takes up the entire face, acting as interchangeable billboard for the gallery. Just above are two enclosed spaces that make up the folk art galleries and on the third level, the moving pictures gallery.



## CHAPTER 4: CONCLUSION

The central premise of the thesis is that Art museum design is fluid. Historically, this fluidity had a deep rooted relationship between content and context; Now, if architects and museum boards continue to slave over the container vs contents debate, the inevitability is that one or the other suffers.

My travels throughout the United States and Europe played an integral part in achieving a set of design criteria. Previously trained in Visual Arts, This thesis has systematically disassembled my previous notion of what an art museum should be. My previous belief in the neutral white box, void of any other contamination, has been forever changed.

Presumably, the effects of this study can help to mend the wounds from either side of the battle field. As more and more cities are looking for the next icon, and as artist, curators, and architects delve into ever more challenging work, it is the joining of forces in the design process, with the intent in producing a productive tension between container, contents, and context, where all three will be illuminated.

**APPENDIX:**

Case Studies



**Cy Twombly Gallery**  
 Location: Houston, TX  
 Architect: Renzo Piano  
 Population: 2,100,000 Greater  
 Boston  
 Square Feet: 9,300  
 1995

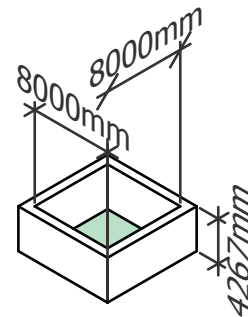

- Other Amenities
- Circulation
- Exhibition
- Services

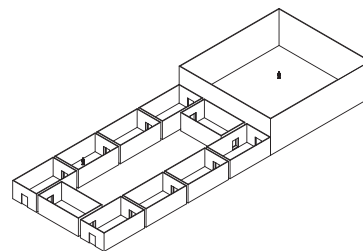

CONTAINER + CONTENTS = PRODUCTIVE  
 CONTAINER + CONTEXT = NEUTRAL

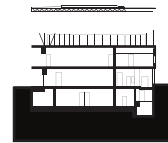
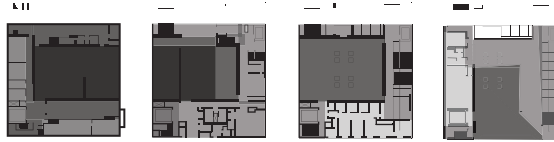

## Aspen Museum of Art

Location: Aspen, CO  
 Architect: Shigeru Ban  
 Population: 7,000  
 Square Feet: 30,000  
 2014

- Other Amenities
- Circulation
- Exhibition
- Services

 50' 100'

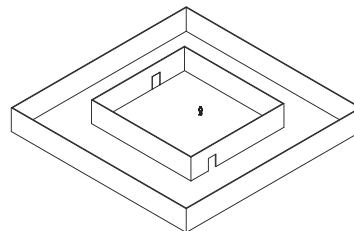

CONTAINER + CONTENTS = NEUTRAL  
 CONTAINER + CONTEXT = PRODUCTIVE

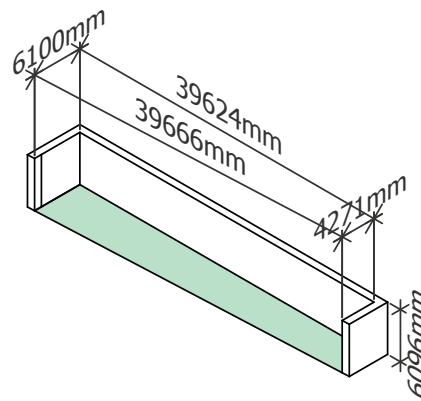
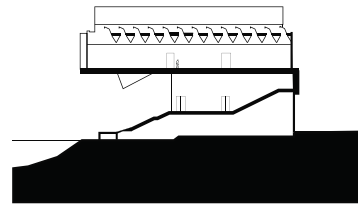
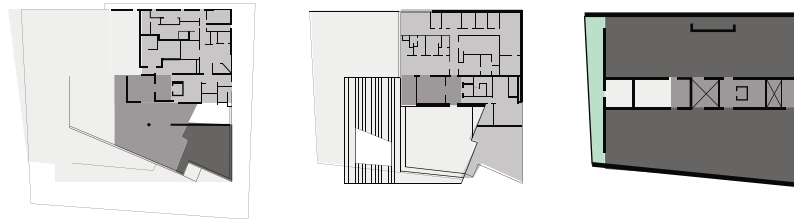

ICA  
 Location: Boston, MA  
 Architect: Diller Scofidio + Renfro  
 Structure: Steel  
 Population: 4,000,000 Greater Boston  
 Square Feet: 65,000  
 2006

- Other Amenities
- Circulation
- Exhibition
- Services

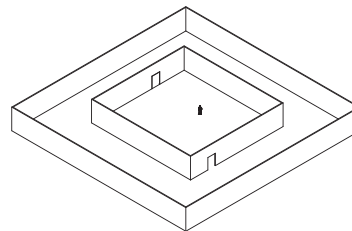
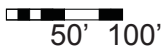

CONTAINER + CONTENTS = PRODUCTIVE  
 CONTAINER + CONTEXT = PRODUCTIVE  
 CONTENTS + CONTEXT = N/A

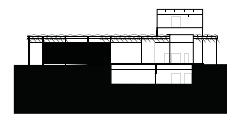
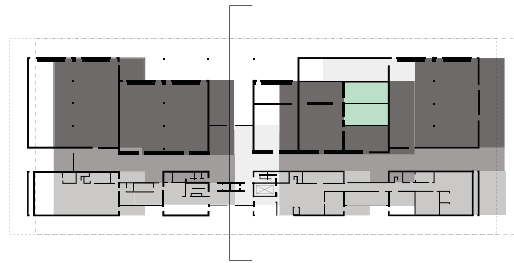

**Menil Collection**  
 Location: Houston, TX  
 Architect: Renzo Piano  
 Population: 2,100,000 Greater Houston  
 Square Feet: 30,000  
 1987

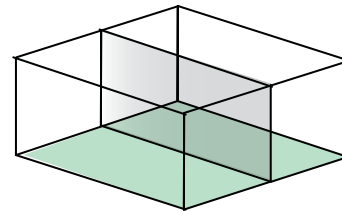

- Other Amenities
- Circulation
- Exhibition
- Services

 50' 100'

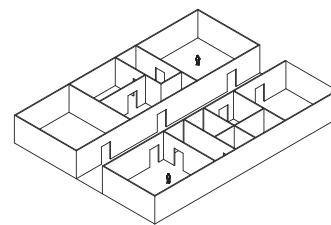

CONTAINER + CONTENTS = PRODUCTIVE  
 CONTAINER + CONTEXT = PRODUCTIVE  
 CONTENTS + CONTEXT = N/A



Contemporary  
Arts Center

Location: Cincinnati, MO  
 Architect: Zaha Hadid  
 Population: 2,200,000  
 Total Square Feet: 91,000  
 2003

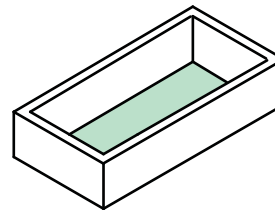

- Other Amenities
- Circulation
- Exhibition
- Services

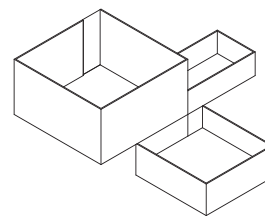

CONTAINER + CONTENTS = PRODUCTIVE  
 CONTAINER + CONTEXT = PRODUCTIVE  
 CONTENTS + CONTEXT = PRODUCTIVE

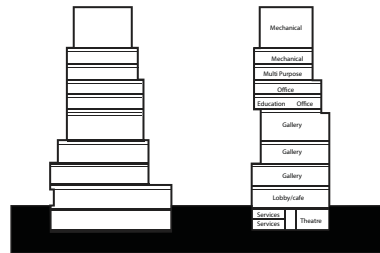
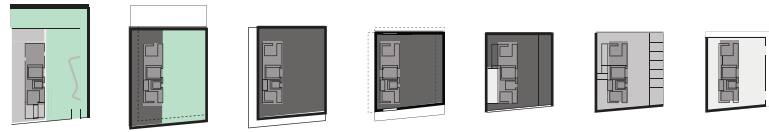

**New Museum**  
 Location: New York, NY  
 Architect: Sanaa  
 Population: 8,490,000 NY  
 Square Feet: 58,700  
 2007

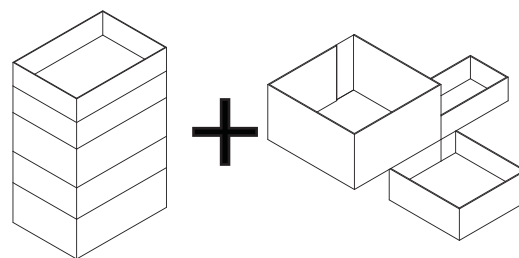
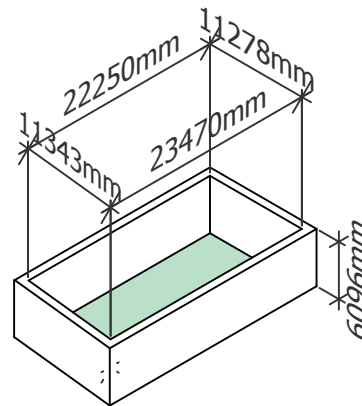

CONTAINER + CONTENTS = PRODUCTIVE  
 CONTAINER + CONTEXT = PRODUCTIVE  
 CONTENTS + CONTEXT = N/A

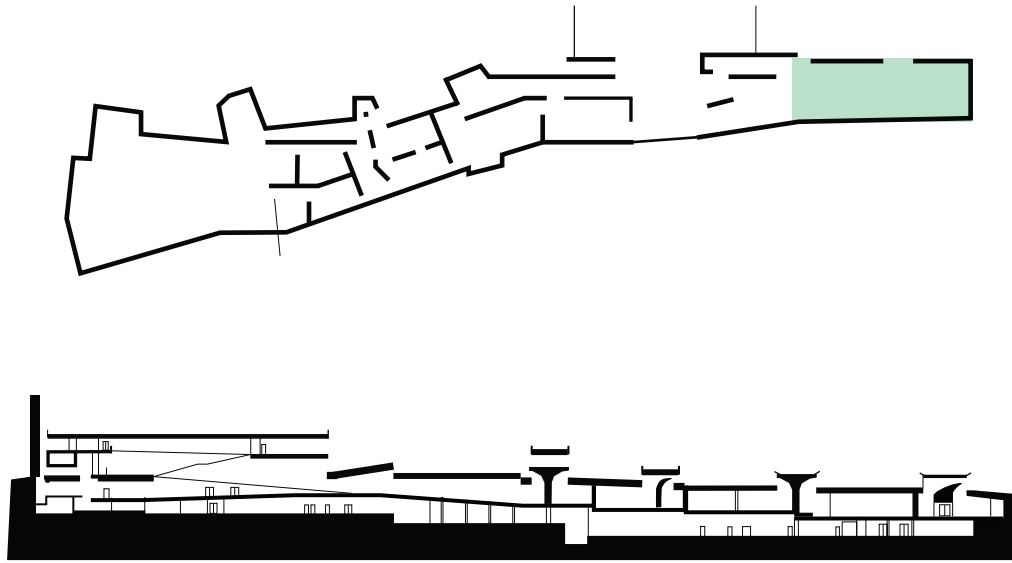

## Nelson Atkins

### Museum

Location: Kansas City, MO  
 Architect: Steven Holl Architects  
 Population: 2,393,623 Greater KC  
 Square Feet: 165,000  
 2007

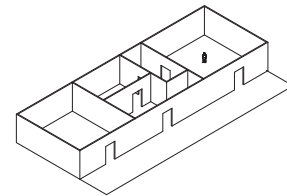
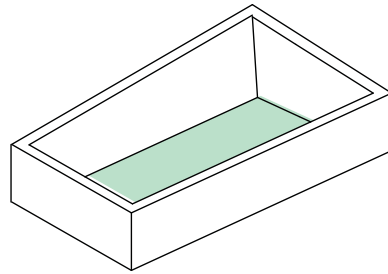

CONTAINER + CONTENTS = NEUTRAL  
 CONTAINER + CONTEXT = PRODUCTIVE



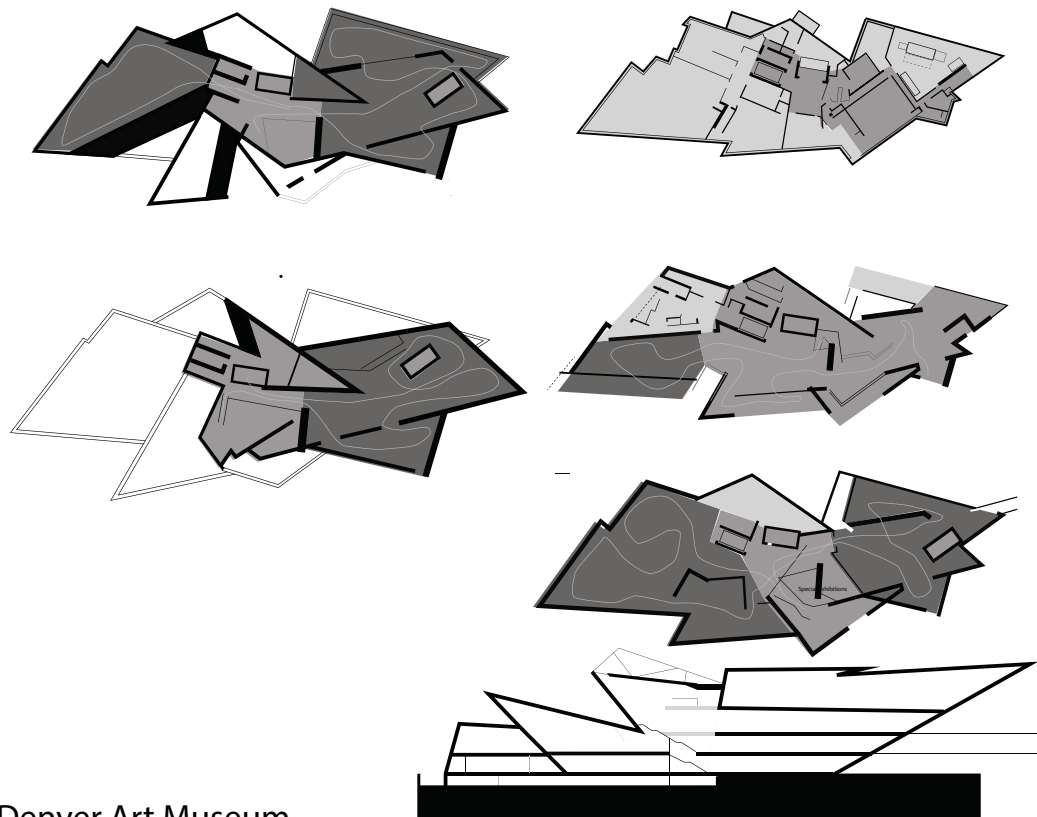

### Denver Art Museum

Hamilton Building, Denver, Colorado

Studio Daniel Libeskind

Facade: 230,000 Square feet of titanium

Structure: 2,740-ton steel structure

Population: 2,599,544 The Denver Metropolitan

Square Feet: 146,000

2006

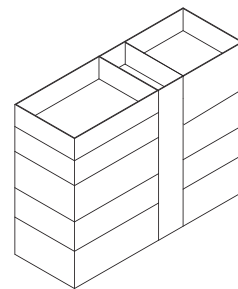

CONTAINER + CONTENTS = UNPRODUCTIVE  
 CONTAINER + CONTEXT = UNPRODUCTIVE

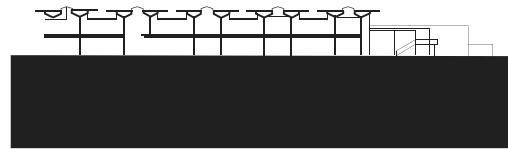
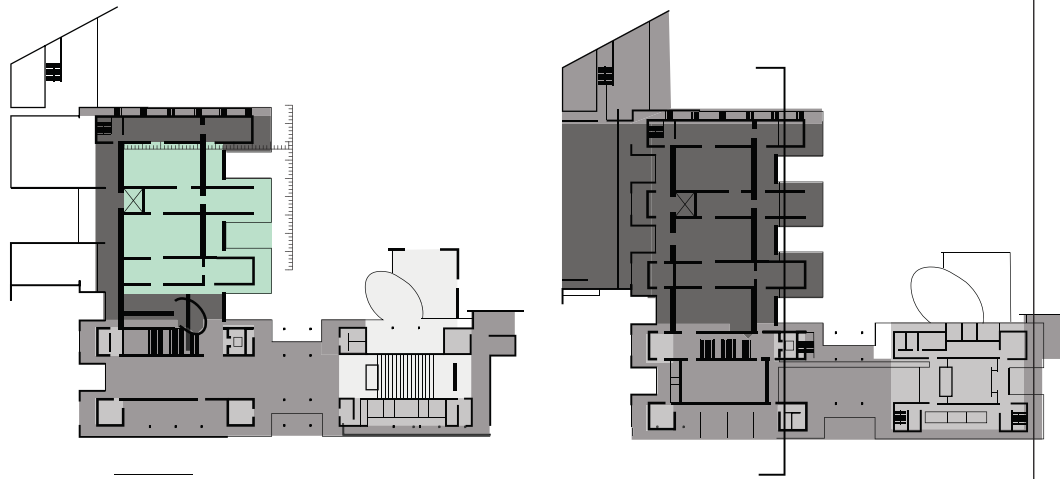

Museum of Modern Art

Location: Fort Worth, TX  
 Architect: Tadao Ando  
 Population: 792,727 Fort Worth  
 Square Feet: 153,000  
 2002

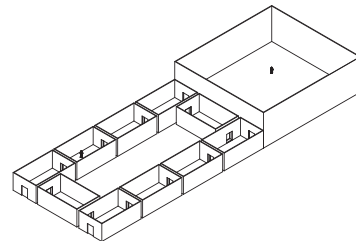
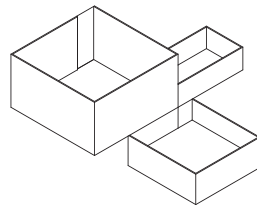
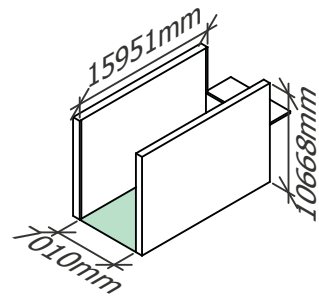

CONTAINER + CONTENTS = PRODUCTIVE  
 CONTAINER + CONTEXT = NEUTRAL  
 CONTENTS + CONTEXT = N/A

## BIBLIOGRAPHY

- “AD Classics: Solomon R. Guggenheim Museum / Frank Lloyd Wright,” Adelyn Perez, ArchDaily, accessed 12 Jun 2015, <http://www.archdaily.com/?p=60392>.
- Bazin, Germain, *The Museum Age*, trans. Jane van Nuis Cahill (New York: Universe Books, 1967)
- “Bilbao One Year Anniversary: Unprecedented Success,” Guggenheim, last modified November 2, 1998, <http://www.guggenheim.org/new-york/press-room/releases/press-release-archive/1998/722-november-2-bilbao-one-year-anniversary-unprecedented-success>.
- Busquets, Joan, Correa, Felipe, *Cities X Lines : A New Lens for the Urbanistic Project* (Cambridge, MA, Harvard University, Graduate School of Design, 2006)
- “Detailed vector map of Nova Scotia,” Nova Scotia Geomatics Centre, last modified 2009, [http://novascotia.ca/sns/pdf/maps/map\\_of\\_nova\\_scotia.pdf](http://novascotia.ca/sns/pdf/maps/map_of_nova_scotia.pdf).
- “Extension to the Denver Art Museum, Frederic C. Hamilton Building,” Libeskind, accessed last modified 2016, <http://libeskind.com/work/extension-to-the-denver-art-museum-frederic-c-hamilton-building/>.
- “Fountain, 1917,” The Marcel Duchamp Studies Online Journal, accessed January 12, 2015, [http://www.toutfait.com/unmaking\\_the\\_museum/fountain.html](http://www.toutfait.com/unmaking_the_museum/fountain.html).
- “The Frank Lloyd Wright Building,” Guggenheim Archives, accessed April 15, 2015, [http://www.guggenheim.org/index.php?option=com\\_content&view=article&id=43&Itemid=99](http://www.guggenheim.org/index.php?option=com_content&view=article&id=43&Itemid=99)
- “Guggenheim Bilbao.” FMGB Guggenheim Bilbao Museoa, last modified 2016, <http://www.guggenheim-bilbao.es/en/the-building/>.
- “Guggenheim Helsinki Design Competition,” Design Guggenheim Helsinki, Last updated 2016, <http://designguggenheimhelsinki.org/stageonegallery/view/>.
- “Halifax Gets it Here,” Port of Halifax, accessed November 22, 2015, <http://www.halifax-getsitthere.com/en/shipping-tools/route-maps.html>.
- “I have seen the future of architecture and it is in poor health,” Rory Hyde, Twitter, <https://twitter.com/roryhyde/status/524989369044963328>.
- “Icon,” The Free dictionary, accessed January 20, 2014, <http://www.thefreedictionary.com/icon>
- Lampugnani Magnago, Vittorio and Sach, Angeli, *Museums for a new millennium: concepts, projects, buildings*. (Munich: Prestel, 2001)

- Mack, Gerhard and Szeemann, Harald, *Art Museums into the 21st Century* (Basel: Boston: Birkhäuser, 1999)
- Newhouse, Victoria, *Towards a New Museum* (New York, N.Y.: Monacelli Press, 2006)
- "The Next Helsinki." *The Next Helsinki*. accessed February 20, 2015, <http://www.nexthelsinki.org/>.
- "The Northern Appalachian/Acadian ecoregion," *Two Contries, One Forest*, last modified 2008, [http://www.2c1forest.org/en/resources\\_docs/special\\_Report\\_1.pdf](http://www.2c1forest.org/en/resources_docs/special_Report_1.pdf).
- O'Doherty, Brian, *Inside the White Cube: The Ideology of the Gallery Space* (1st Book ed. Santa Monica: Lapis Press, 1986)
- "Picture Dictionary of Modern Architecture: High-tech," *About.com*, accessed March 6, 2016, <http://architecture.about.com/od/20thcenturytrends/ig/Modern-Architecture/High-Tech.htm>.
- "Razor-Sharp Profile Cuts Into a Mile-High Cityscape." Nicolai Ouroussoff, *The New York Times*, October 11, 2006, accessed October 31, 2014, [http://www.nytimes.com/2006/10/12/arts/design/12libe.html?\\_r=2&](http://www.nytimes.com/2006/10/12/arts/design/12libe.html?_r=2&).
- "The Tribuna of the Uffizi," *The Royal Collection Trust*, last modified 2016, <https://www.royalcollection.org.uk/collection/406983/the-tribuna-of-the-uffizi>.
- "World Map Vector," *Freepik*, accessed October 20, 2015, [http://freepik.com/free-vector/world-map-vector\\_71267.htm](http://freepik.com/free-vector/world-map-vector_71267.htm).