

DEVISING A MODIFIED FLANKER TASK TO OBTAIN EVENT RELATED BRAIN
POTENTIALS FOR THE ASSESSMENT OF ATTENTION

by

Ishika Sharma

Submitted in partial fulfilment of the requirements
for the degree of Master of Science

at

Dalhousie University
Halifax, Nova Scotia
August 2014

© Copyright by Ishika Sharma, 2014

Table Of Contents

List Of Tables	v
List Of Figures.....	vii
Abstract	ix
List Of Abbreviations Used.....	x
Acknowledgements	xi
Chapter 1 Introduction	1
1.1 Executive Summary.....	1
Chapter 2 Background And Rationale.....	6
2.1 Cognition.....	6
2.2 Cognitive Control And Executive Functions.....	7
2.3 Attention: An Executive Function.....	10
2.4 Electroencephalography (EEG) And Event Related Potentials (ERP).....	15
2.4.1 P300.....	17
2.4.1a Discovery Of The P300 And Its Correlation With Updating Of The Mental Schema.....	17
2.4.1b P300 Amplitude And Latency: Its Relation To Attention.....	18
2.4.1c Components Of P300: P3a And P3b.....	25
2.4.1d Assessment Of P3a And P3b: Eeg And Three-Stimulus Oddball Paradigm.....	26
2.4.1e Changing Face Of The Oddball Task In The Study Of P3a And P3b.....	29
2.5 Flanker Task: Exploring Attention And Inhibition.....	30
Chapter 3 Objectives And Hypotheses.....	36
3.1 Objectives.....	36
3.2 Hypotheses.....	36
Chapter 4 Methods	38

4.1 Participants.....	38
4.1.1 Inclusion And Exclusion Of Participants.....	38
4.1.2 Participant Recruitment.....	41
4.2 Measures For Collecting Baseline Participant Characteristics.....	41
4.2.1 Screening Form.....	41
4.2.2 Edinburgh Handedness Questionnaire.....	41
4.3 Experimental Design.....	41
4.3.1 Tasks.....	42
4.3.2 Experimental Set Up.....	45
4.4 Procedure.....	46
4.4.1 Randomization Of Order.....	46
4.4.2 Orientation Sessions.....	47
4.4.3 EEG Preparation.....	47
4.4.4 Experiment.....	48
4.5 Analysis.....	49
4.5.1 Behavioural Analysis.....	49
4.5.2 Electrophysiological Analysis.....	50
4.5.2a Pre-Processing.....	50
4.5.2b Event Related Epochs And Individual Averages.....	50
4.5.2c Group Averages.....	51
Chapter 5 Results.....	52
5.1 Reaction Time And Error.....	52
5.2 ERP Analysis For Mixed Modality Flanker Task.....	60
5.3 ERP Analysis For Single Modality Flanker Task.....	65
5.4 ERP Analysis For Oddball Task.....	69
5.5 ERP Comparisons For Target And Distractor Trials.....	72
Chapter 6 Discussion.....	76
6.1 Main Findings.....	76
6.2 The Modified Flanker Tasks.....	78

6.2.1 Late Positive Complex	78
6.2.1a Late Positive Complex Obtained For Distractor Trials.....	79
6.2.1b Late Positive Complex Obtained For Distractor Trials....	81
6.2.2 N200.....	85
6.2.3 N100 And P200.....	88
6.3 The Oddball Task.....	93
6.3.1 The N350.....	93
6.4 Reaction Time Analysis.....	98
6.5 Limitations And Future Directions.....	99
Chapter 7 Conclusion.....	103
References	105
Appendix 1 Screening Form.....	121
Appendix 2 Edinburgh Handedness Inventory (by Oldfield, R.C., 1971).....	122
Appendix 3 Consent Form.....	123
Appendix 4 Participant Background Information.....	134

List Of Tables

Table 1. Task Conditions For The Flanker. Reproduced From Eriksen And Eriksen(1974).....	31
Table 2. Groups For Participant Randomization.....	46
Table 3. Average Reaction Time (Rt; Seconds) For All Forty Participants On The Target Trials	53
Table 4. Anova Results For Reaction Times On The Congruent Trials Of Both The Modified.....	56
Table 5. Anova Results For Reaction Times On The Incongruent Trials Of Both The Modified.....	57
Table 6. Percent Error* For Target Trials (Mixed And Single Modality Flanker Tasks).....	60
Table 7a. Peak Amplitudes And Latencies Of The ERPs For Congruent Trials Of The Single.....	62
Table 7b. Peak Amplitudes And Latencies Of The ERPs For Incongruent Trials Of The Single	62
Table 7c. Peak Amplitudes And Latencies Of The ERPs For The Distractor Trials Of The Single.....	63
Table 8a. Peak Amplitudes And Latencies Of The ERPs For Congruent Trials Of The Mixed.....	66
Table 8b. Peak Amplitudes And Latencies Of The ERPs For Incongruent Trials Of The Mixed.....	66
Table 8c. Peak Amplitudes And Latencies Of The ERPs For Distractor Trials Of The Mixed.....	67

Table 9a. Peak Amplitudes And Latencies Of The ERPs For The Target Trials
Of The Oddball ,, ,, ,, ,, ,, ,, ,,69

Table 9b. Peak Amplitudes And Latencies Of The ERPs For The Distractor
Trials Of The70

List Of Figures

Figure 1. Obtaining Event-Related Potentials: A. Set-Up Used For Recording EEG Signals	16
Figure 2. Graphs Depicting Statistical Correlation ($R=0.66$ For Accurate-RT And	20
Figure 3. Illustration Of Tasks Used For P300 Analysis By Strayer And Kramer (1990) A.	22
Figure 4. Different Tasks Performed To Obtain Different Components Of P300: The Topmost	28
Figure 5. P300 Analysis In Single Task (Flanker Task) And Dual Task (Flanker + Sternberg).....	33
Figure 6. The Panel On The Left Clearly Shows The Larger P300 Amplitude For The 20-29	39
Figure 7. Effect Size Analysis Of P300 Amplitude (Left Panel) And, P300 Latency (Right)	40
Figure 8. Effect Size Analysis Of P300 Amplitude (Left) And P300 Latency (Right) With.....	40
Figure 9. Modified Flanker Tasks Used For Assessment Of Attention Included The Mixed	44
Figure 10. Three-Stimulus Auditory Oddball Task Used For Assessment Of Attention. A.	45
Figure 11. Mean Reaction Times (RT) And Standard Deviation Plotted For The Congruent.....	58
Figure 12. Mean Reaction Times(S) And 95% Confidence Intervals Plotted For The.....	59

Figure 13. Grand Averaged ERPs (N=40) Obtained For The Congruent (Red, 2800 Trials),.....	64
Figure 14. Grand Averaged ERPs (N=40) Obtained For The Congruent (Red, 2800 Trials),.....	68
Figure 15. Grand Averaged ERPs (N=39) Obtained For The Target (Orange, 780 Trials),.....	71
Figure 16. Grand Averaged ERPs Obtained For Target Stimuli On Channels Fz (A), Pz(B).....	73
Figure 17. Grand Averaged ERPs Obtained For Novel Stimuli On Channels Fz (A), Pz (B).....	75
Figure 18. Experimental Setup For Presenting The Novel And Familiar Toys In A 3D Display.....	80
Figure 19. ERPs Obtained On Two Choice (2CR) And Four Choice (4CR) Reaction Tasks.....	84
Figure 20. ERPs Obtained On The Go (Solid Line) /No-Go (Dotted Line) Task In The	90
Figure 21. ERPs For A. Go Trials And B. No-Go Trials For Children With ADHD (Solid Line).....	92
Figure 22. ERPs Obtained During Task Performance In Attend Condition As Participants	95

ABSTRACT

Electrophysiological indices of attention provide insight into the neural processes underlying attention. These indices include the P300 and its sub-components, the P3a and P3b, which are event related potentials (ERPs) reflecting stimulus evaluation and response execution. Paradigms used to elicit these ERPs have limitations, and thus alternative paradigms are needed. **Purpose:** To test the ability of an alternative paradigm, the Flanker task, for eliciting the P300 and its sub-components. **Methods:** Mixed and single modality Flanker tasks were used to elicit ERPs from 40 non-disabled adult participants. Results were compared to ERPs obtained from a standard paradigm, the oddball task. **Results:** Neither the P300 or its sub-components were observed for the three tasks. Alternate ERPs indicative of selective attention and novelty were observed for the Flanker tasks. **Conclusion:** The modified Flanker tasks elicited ERPs indicative of the neural processes underlying attention, however the ERPs obtained did not correspond to those anticipated.

LIST OF ABBREVIATIONS USED

EEG	ELECTROENCEPHALOGRAPHY
ERP	EVENT RELATED POTENTIAL
SM-I	SINGLE MODALITY (FLANKER TASK)- INCONGRUENT TRIAL
SM-C	SINGLE MODALITY (FLANKER TASK)- CONGRUENT TRIAL
MM-I	MIXED MODALITY (FLANKER TASK)- INCONGRUENT TRIAL
MM-C	MIXED MODALITY (FLANKER TASK)- CONGRUENT TRIAL
OB	ODDBALL TASK
PET	POSITRON EMISSION TOMOGRAPHY
EOG	ELECTROOCULOGRAM
RT	REACTION TIME
MRI	MAGNETIC RESONANCE IMAGING
3D	THREE-DIMENSIONAL
2D	TWO-DIMENSIONAL
<i>d</i>	EFFECT SIZE

ACKNOWLEDGEMENTS

The work done towards the completion of this thesis does not solely represent my work but also the collaboration of many individuals that have been my support structure throughout this project. Two years ago when I first stepped in Halifax, miles away from my home in India, my supervisors Dr. Shaun Gregory Boe and Dr. Marilyn MacKay-Lyons became my new family. I would like to extend my gratitude towards them for providing me with a multitude of opportunities to grow as a student, a physiotherapist, a researcher and an individual. It was a challenge to work on a topic that is beyond the scope of my background in physiotherapy and rehabilitation, but they made it an easy transition for me, allowing me to continue to work in the clinical realm as I worked on this project and learned newer concepts. I thank them for helping me find a balance.

I would like to extend my gratitude to Dr. Olav Krigolson, who has played an important role in making me understand the concept of event related potentials. His support, from the day I had laid a proposal for this project until the interpretation of the results, has been very important for the successful completion of this project. Additionally, I thank Dr. Steve Aiken for taking the time to teach me the basic concepts of audiology that were relevant for choosing and applying the sound clips for our experiment.

I would like to especially thank Ross Story, for bearing through the process of designing the paradigms for this task. With my lack of experience in computer languages, Ross not only wrote the code for the program but was patient in teaching me the basics so that eventually I could handle the software by myself. I thank him for his availability and for his input towards the completion of the task paradigms. Additionally, I am grateful for the support of all the members of the Laboratory of Brain Recovery and Function. They have been great friends, amazing colleagues and good critics. Their guidance has always yielded favourable outcomes for this project.

Beyond the school and the lab, my strongest foundation has been built upon the care, faith and pride of my family, apartment-mates and best friends. I thank Asraa Maryam and Priya Anand, who have supported me from miles away and boosted my confidence at every step since the day I left my hometown to come to Canada. Our friendship since the last seven years has been a motivator at each phase of my life. I thank Ajitpal Sian, Rohit Gupta, Aishwarya Kamat and Anuj Duggal for helping me divide responsibilities at home while I spent hours working in the lab. I thank them for making life in Halifax easy, fun-filled and fruitful. I especially thank Rahul Singh for being there in times of the biggest conflicts I have faced. He has helped me break free from them so I can bring my focus back to what was important. Graduate school has been a beautiful experience with him. His love has only furthered my progress on both professional and personal fronts.

But most of all, there have been two people who have endured most challenges as I have tried to work towards my ambitions. My parents are all the reason why I am in

Dalhousie University. It has been two years since we met ever since the day I left for graduate school but that has not deterred them from constantly playing a part in my life. They have consistently motivated me to work on my goals and be focused towards achieving them. We have been through hard times in these last two years but they have been bolsters to my confidence and faith. Everything I am and everything I have is because of my parents. I am grateful to God for providing our family with such strength and patience.

So thank you everyone for making graduate school and research an astounding experience for me!

CHAPTER 1: INTRODUCTION

1.1 Executive Summary

Cognition is an umbrella term for a group of mental processes that are a part of our day-to-day living. Attention, memory, decision-making, language learning and problem solving are all a part of an individual's cognitive processes. These mental processes can be a conscious effort or they can be a part of our subconscious. Cognitive functions that help regulate and manage other mental processes are considered to be executive functions. These processes guide our actions and determine task performance. Control of these cognitive processes is what makes us flexible to novelty in the environment and how we respond to it. Hence, there is an ongoing interest in studying the potential source of these processes and how these mental processes can be quantified for further analysis of cognitive abilities and the brain activity associated with them.

Loss of brain function due to aging, a neurological insult like stroke or an inherent psychological disorder such as attention deficit hyperactivity disorder, may affect attention. In light of the increased prevalence of these conditions in society and growing interest in improving attention by means of cognitive training, it is essential to have an assessment tool that helps us understand the effects of these conditions as well as those of cognitive training. For the most part, researchers have been using behavioural measures for assessing attention by reporting how well a person focuses during a task in terms of reduced error rate and decreased reaction time in performing an attention-based task.

However, there is a lack of data related to the objective analysis of the underlying neural mechanisms that are associated with attention. Thus, we need a good tool to assess and quantify brain activity associated with attention.

The brain is a functional entity that is active during any type of physiological activity and during our thought processes. For every task planned and every movement performed, pertinent regions of the brain are activated via changes in the electrical potential of the neurons comprising that region. These changes in electrical potentials can be recorded as electrical activity on the electroencephalogram (EEG). Voltage fluctuations over time resulting from sensory, cognitive and motor events can be obtained from the continuous EEG recording. The voltage fluctuations time-locked to a given event are referred to as event-related potentials, or ERPs. ERPs are similar in their causality, i.e., occurrence of an event, but they differ based on the time period when they occur and the nature of stimuli that evokes them.

My research was aimed at studying the P300. The P300, or P3 as it is often referred, is a positive waveform that occurs in the 250-500 ms window (approximately 300 ms) after a stimulus on an attention related task. The P300 has two sub-components, referred to as the P3a and P3b respectively. The P3b appears later than the P3a on the EEG. The P3b is synchronous with controlled attentive processing (motor e.g., key pressing or non-motor e.g., mental counting) whereas the P3a is related to the time-point when information processing is initiated in the brain upon presentation of a novel stimulus. Thus the P3a component of the P300 quantifies primarily the brain activity

associated with attention and information processing while P3b represents the brain activity that is a combination of stimulus evaluation and response.

It is difficult to pull the two components apart as information processing and task execution for a given stimulus occurs within a very small and overlapping time frame. Thus, to study the P3a and P3b separately researchers most often use an auditory three-stimulus oddball task. The oddball task requires the participant to press a key when they hear a target tone and not respond when they hear a standard tone (the participant is first familiarized with the sound of both tones). A third tone that the participant is not anticipating is also played. A novel stimulus such as this third tone requires no response from the participant, and thus only results in orienting the attention of the participant. If the oddball task is performed in conjunction with EEG, the novel stimuli result in a P3a waveform on the EEG recording.

Researchers have used the auditory three-stimulus oddball task in conjunction with EEG to study brain activity related to attention since 1970s. Since by their nature ERPs are event related, the type of the stimulus can affect the ERPs obtained. Thus, researchers have tested variations to the oddball task to find out the most suitable parameters of stimuli that can help elicit the ERPs associated with attentional processes. For instance, the effect of varying the stimulus modality in this task and using two-versus three-stimulus oddball has been tested. However, the results from these experiments have not been able to suggest a particular variation that can be best used to quantify attention. Besides the oddball task, the Flanker task has also been used to assess measures of

attention. The Eriksen Flanker or simply the Flanker task was designed to study the ability to suppress responses that were not required within a context. Thus, it is primarily used to behaviourally assess attention as an individual inhibits other irrelevant stimuli in the environment. The Flanker is one of the most used paradigms to test an individual's behaviour associated with attention demanding tasks. However, rarely has anyone used this task to study the electrophysiological activity associated with attention. Even though researchers have been able to obtain the P300 using a Flanker task, they have not explored whether this task can generate more distinct P300 sub-components, i.e., the P3a and P3b, compared to the oddball paradigm. To explore the effect of stimulus type and task variation on the electrophysiological variables of attention, we attempted to obtain the P3a and P3b components of attention using two modified versions of the Flanker task.

We tested our modified versions of the Flanker task (mixed and single modality stimulus, explained in following sections) as well as the three-stimulus auditory oddball task in 40 non-disabled participants in an attempt to compare and contrast the behavioural and electrophysiological measures of attention obtained. Upon analysis, we noticed a large, late positive ERP complex for both the mixed and single modality Flanker tasks but not for the oddball task. Additionally we observed larger early ERP components (N100, P200) for the modified Flanker tasks but not for the oddball task. These ERP components play an important role in inhibition and selective attention. Another negative ERP, the N200, was obtained for the mixed, but not the single modality, Flanker tasks. The N200 is an important indicator of novelty. Interestingly, we were not able to obtain a P300 waveform, or its sub-components, from any of the tasks. Additionally, the oddball

task generated an N350 ERP, which is indicative of a state of drowsiness. This finding suggests that the oddball task was monotonous and not engaging for our participants, and as a result no indicators of attention or inhibition were observed. Collectively, these results suggest that although none of the tasks were able to provide for analysis of the P300 and its components, the modified Flanker tasks were able to elicit ERPs with which we can quantify attention to novelty and inhibition processes.

CHAPTER 2: BACKGROUND AND RATIONALE

2.1 Cognition

Cognition is a word of Latin origins (con: with; gnosco: know) that defines the complex processes whereby an individual, owing to their experiences in the world, attends to the ongoing challenges, compiles the information, applies knowledge to make a decision and solves problems. Almost 20 centuries ago, Aristotle started research in the fields of memory and perception. Owens (1976) describes in his article how Aristotle attempted to explain the concept of cognition, and cognition in itself, as a being and an objective entity. Thought processes and philosophy were studied extensively for at least a twenty-year period around the 1950's and 1960's. This period was termed the 'cognitive revolution' and cognitivism eventually became a dominant field of psychology.

The human brain has distinct mental and behavioural abilities (Gagneux, P. and Varki, A., 2001). Aging (Kray, I., 2006) and clinical conditions like schizophrenia (McGhie, A, & Chapman, J., 1961), stroke, brain tumor (Bruhn, P. & Parsons, O. 1971, Van Zomeren, 1985), attention deficit hyperactivity disorder (Barkley, R.A., 1997) etc. can affect these mental abilities. As a result, researchers and rehabilitation professionals have been trying to find treatment and rehabilitation regimens to optimize brain re-training (via brain recovery) to enhance function in these mental domains. With the growing interest in re-training the brain, curiosity about finding mechanisms underlying brain activity associated with different domains of cognition has risen. As much as

researchers are trying to study the brain structure through imaging techniques, they are also focussing strongly on assessing the brain function by studying the neuroscience of cognition. Thus, the term ‘cognitive neuroscience’ was coined, indicating the predilection of researchers towards analysis of how brain function affects our cognitive processes that guide us through our daily life.

Many researchers have tried to explain the need of understanding mental processes and the roles they play in our lives. Sperry (1988) describes how people have long focussed on our behaviours and actions affecting our brain in a bottom-up manner, and how it is still important to study the causal effect of the ‘non-existent’ concepts like mental functions that ascribe the brain a role of top-down control of our behaviours and functions. Such questions eventually led to the understanding of the term cognition as a representation of various mental processes like memory, attention, problem solving, judgement and relevant searching, which, in turn, can be affected by experiences, development, social influences, pathology and injury. The overarching role of cognition in our daily function provides rationale for why it is important to study these processes.

2.2 Cognitive control and Executive functions

High-order cognitive processes like mindfulness, inhibition of behaviour and working memory together comprise the executive functions (Black, D.S. et al, 2011). Executive functions are those mental processes that regulate, control and manage other cognitive processes and help an individual during non-routine situations that are novel,

complex or conflicting in nature (Elliott, 2003; Goldberg, 2001; Denckla, M.B. 1996; Godefroy, O. 2003). These processes include planning, memory, attention and problem solving. Lezak defined executive functions as “those capacities that enable a person to engage successfully in independent, purposive, self-serving behaviour” (Lezak, 1995).

Studies to examine the importance of executive function have mostly involved research conducted on participants with frontal lobe lesions, since the frontal lobe is associated with maintenance of executive functions (Duncan, R. et al., 1997). Information regulation, which is often used synonymously with executive functions (Towse, J. et al, 2007), is incomplete if an individual is unable to establish properly represented and functionally available behavioural goals. Such an individual, despite having basic cognition, is unable to execute his or her more complex thought processes towards regulating and accomplishing their goals (Zelazo, et al, 1997). This is called goal neglect. Executive functions have been shown to be accessible to consciousness and they help deal with novel tasks, which include goal setting and setting sequences of behaviours to achieve that goal as well (Rabbitt, P. 1997). When individuals have frontal lobe lesions, Duncan (1986) postulated that these individuals eventually end up with goal neglect associated with loss of their executive functioning capacity. Duncan further suggested that individuals with such lesions are incapable of assembling fragmented sequences of action to set a goal and end up omitting relevant actions resulting in goal neglect. This finding led to the notion that loss of frontal lobe activity can significantly affect executive functions in an individual.

Executive functions have also been known to prevent inappropriate responses as well as with helping an individual to cope with new task demands by detecting and correcting errors (Rabbitt, P. 1997). Executive functions allow a person to cope with task demands by maintaining attention continuously, which helps an individual predict outcomes of long sequences of events. The impact of altered executive functioning on voluntary attention was demonstrated in a research study conducted by Wilkins et al (1987), who were able to show that patients with right frontal lobe lesions, when presented with a task of counting a succession of 2-11 stimuli, were less able than others to sustain attention voluntarily. The stimuli were either binaural (relating to two ears) clicks or pulses on the right or left index finger presented at different frequencies. Impairment in the ability to sustain attention was observed for stimuli with a frequency of 1 compared to 7 Hz. This finding suggested that the ability to sustain attention during monotonous and slower tasks (i.e., the 1 Hz frequency used in the study) was reduced in the patients. Similarly, Janowsky et al (1989) successfully demonstrated that with frontal lobe dysfunction, irrespective of age, the errors in describing the source of memory (i.e., where and when facts about a given memory were learned) increased significantly. On a memory task, the participants with frontal lobe lesions were able to remember recently learned facts but frequently made mistakes in identifying the source associated with those facts. This study clearly described the role of executive functions in errorless learning and fact retrieval. Many researchers have used errorless learning and fact retrieval related paradigms to train the executive function in an individual with brain disease or trauma, and have noted subsequent improvement in their instrumental activities of daily living (Sitzer et al 2006, Grandmaison and Simard (2003), Bier et al 2006, Thivierge, S. et al,

2008). Thus, it is sufficient to say that executive functions are key to the many activities that are associated with our daily living.

There are a variety of views among researchers about whether the term ‘executive function’ refers to a single function or a variety of frontal lobe functions (Duncan, R. et al., 1997; Miyake, A. et al, 2001; Carlson, S.M. 2005; Salthouse, T.A. et al, 2003). However, most neuropsychologists and experimental psychologists have agreed upon the concept that executive attention or inhibition and working memory are key mental processes that are a part of executive functioning of the human brain (Blair, C. et al, 2005; Fletcher, J.M., et al 1996; Pennington, B.F., et al, 1996; Pennington & Ozonoff, 1996; Shallice, T. et al., 1996).

2.3 Attention: An executive function

Attention is the ability of an individual to focus upon a specific task or event by ignoring all the irrelevant stimuli or the distracters in their surroundings. Norman and Shallice (1980) have proposed a two-system model of attention whereby the first system is the supervisory attentional system that is associated with executive control of attention, and the second is the contentional scheduling system that controls more automatic aspects of attention. There are schemas or scripts that are basically the responses that are initiated as part of our mental processes every time there is a stimulus. Norman and Shallice suggest as part of their attentional model that routine activities that demand a certain response or a schema initiate the choice of an appropriate schema by turning on the

contentional scheduling system, which is a more automatic process. For instance, reading the words on a page is an automatic process in which the contentional scheduling system recalls schema associated with memory of letters of the alphabet and general rules of how they are strung together to make words. However, if suddenly a spider fell on the page, the situation would be different. In such an occurrence, the supervisory attention system takes action, helping to identify the change perceived from the spider falling on the page. At this point, the automatic tendency to read the words would be inhibited and shifted towards reacting to the presence of a spider on the page. This situation demands greater attention of mental resources. Thus, in such a situation, the supervisory attention system inhibits the contentional scheduling system and prevents exhibition of any of the previously learned schemas in novel situations. The supervisory attentional system builds upon the contentional system and makes use of previously known schemas to guide a response towards novel situations. In addition to describing models of attention, the supervisory attention system has also been used to describe a model of working memory. Working memory is a part of short-term memory that is associated with immediate perceptual processing. How new information is gathered, processed and applied to execution of an action, is often associated with use of working memory to update the mental schemas (as described in the Norman and Shallice model). It was Baddeley and Hitch's model of working memory (1974) that described this concept. According to this model, working memory is comprised of a system including the central executive that acts as a controlling and regulation center for the input of information from the environment and two temporary stores of memory (phonological and visuo-spatial stores). As new information is gained from the environment during an event, it is adjusted

within the central executive, which coordinates between focussing and switching attention (like the supervisory attention system). Useful information is temporarily stored in the phonological or visuo-spatial stores, which also trace older memory associated with a similar event. All of this information is again processed within the central executive before any new memory traces are stored in the long-term memory. Thus, attention is an executive function that monitors and controls our responses to a particular novel and demanding task and also assists in retrieving and storing new and useful memory about an event.

As outlined above, attention is an important executive attribute of the human brain that allows us to function in novel and learned situations by focussing our efforts towards relevant stimuli in our environment. Mirsky (1987) suggested that attention results from coordination of various elements that work in the same system, which makes it an important cognitive process that regulates many of our behaviours. Posner and Petersen (1989) describe in detail how the study of attention is important for us primarily because of the way it connects the central processing functions of cognitive science to the anatomy studied in neuroscience. Posner and Petersen describe how attention is the one executive function that holds a key top-down, and thus causal effect, over various activities we perform in our daily living. Their idea of how attention is regulated by a network of anatomical areas in the brain and how attention regulates not one but a multitude of cognitive competencies (Posner et al, 1988) was further analysed by Compton et al (1991). Compton and his colleagues conducted an experiment where participants performed attention demanding neuropsychological tasks that involved

spatial detection of letters, thickness and case search tasks, and lexical decision making tasks bringing attention to a word-level where discrimination was to be made between words and strings of consonants. For example, participants had to identify a thickening in one letter in a string of 4 or six letter words or strings of consonants. Additionally, the participants identified one lower case letter in a series of multiple upper case letters. Lastly, to test the lexical decision making, participants had to determine if a given string of letters in front of them was a meaningful word or not. These tasks were performed while EEG was recorded. The electrophysiological data obtained by the researchers was compared with positron emission tomography (PET) data associated with the areas of interest examined during their electrophysiological analysis. They were able to show that multiple brain areas were activated, as shown by EEG and PET, when an individual was involved in performing an attention-demanding task. When different components of each task were analysed, the authors noticed that a difference in task and task instructions resulted in use of different representations in the brain to make the judgement about that task. This suggested that many other mental processes function along with attention in order to make judgement about a given task. Not one, but a network of multiple areas is what results in attentional responses.

Attention can be assessed in many ways. Researchers have, for the most part, studied the behavioural aspects of attention. These include accuracy measures and ‘mental chronometry’, which is the time dependent analysis of cognitive processes that makes use of response or reaction time analyses that, in turn, help infer the duration and sequence of events associated with a cognitive process. Many neuropsychological tasks

can be used to assess the behavioural measures of attention. One commonly used neuropsychological test for assessing behavioural aspects of attention is the spatial cuing paradigm (Eriksen and Hoffman, 1972; Posner, 1978; Posner et al, 1980). An example of this paradigm was used in a study conducted by Friedrich et al (1998) that compared spatial attention in participants with superior parietal or temporo-parietal junction (TPJ) lesions. The spatial cuing paradigm involved having each group detect a previously cued target and respond appropriately (Posner, 1980). The authors noticed depleted or slowed response times for the group with TPJ lesion compared to the group with superior parietal area lesion, suggesting slower attention shifts in the TPJ lesion group. Besides the spatial cuing paradigm, two other more commonly used neuropsychological tests of attention include the oddball and the Flanker task, both of which are discussed in detail in following sections.

Despite the wide range of data available from previous studies regarding behavioural analyses of attention, it is important to delve deeper and understand the physiological basis of attention and underlying mechanisms in the human brain that guide this executive function. It is important to understand how brain activity and function result in an interplay of mental processes that guide our behaviours. For a more physiological understanding of attention, researchers have tried to quantify brain function with data from electrophysiological analyses using EEG.

2.4 Electroencephalography (EEG) and Event-Related Potentials (ERP)

Electroencephalography (electro- related to electricity; enkephalon: brain; graphie: to record) is a signal recording technique which was first performed on humans in 1924 by Hans Berger after Richard Caton discovered electrical activity in exposed cerebral hemispheres of the rabbit and monkey brains in 1875 (Haas, L.F. 2003). Referred to as EEG, it is the most commonly used technique for recording brain electrical potentials via measurement of the voltage fluctuations due to ionic current flow in the neurons of the brain (Niedermeyer, E. and da Silva, F.L. 2005). Given that the electrical activity of single neurons is too small to be recorded by EEG electrodes overlying the scalp (Nunez, P.L. 1981), the recording obtained is a summation of the activity of neurons firing in a synchronous manner.

By averaging the EEG data for an event of interest it is possible to ‘average-out’ the activity that is not related to the event or specific stimulus from the analyses. This event-related averaging increases the signal-to-noise ratio and allows us to study voltage fluctuations related to a specific stimulus or event across a wide range of amplitudes. These ERPs reflect the brain’s response to sensory, cognitive and motor events (Luck 2005). An example of event-related potentials is shown in Figure 1. The figure basically shows how a continuous EEG, obtained using a neuropsychological task (participant had to press specific keys each time they saw an X or an O on the monitor), can be averaged to obtain event-related potentials (Luck, S.J. 2014). Event-related potentials have different components (Luck & Kappenman 2011) such as negative (N100, N200,

contingent negative variation, error-related negativity) or positive (P200, P300) waveforms. The letters ‘N’ and ‘P’ describe whether the waveform is negative or positive and the numbers (e.g., 100, 200, 300) depict the onset (in milliseconds) of the waveform in relation to the stimulus. Each component signifies a different nature of event. For example, the P300 has been associated with attention and working memory (Polich 2007) while the N100 is elicited during initial sensory processing and early selective attention (Simons, C.J. et al, 2011). The earliest recorded ERP was the contingent negative variation, which is a negative polarity ERP that occurs 260-470 ms prior to a stimulus and that reflects brain activity associated with prediction of a stimulus after a cue or warning signal (Walter, W.G. et al, 1967).

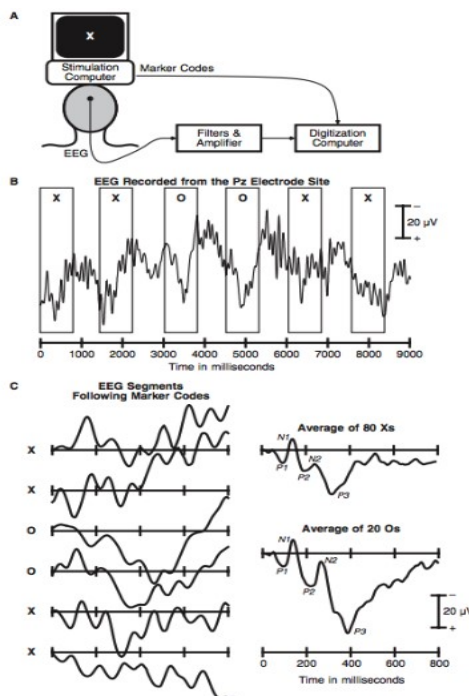

Figure 1: Obtaining event-related potentials: A. Set-up used for recording EEG signals while the participant performs neuropsychological tasks on the monitor, B. Continuous EEG data obtained from the experiment, C. Result of averaging the continuous data for specific events (80% X’s and 20% O’s). Obtained from Luck, S.J., 2014.

An event-related analysis is one of the ways to quantify or characterize the mental process that is known to guide a response or behaviour. Many studies in the past have used ERP variables (including amplitude and latency) to quantify various mental processes. For instance, the P300 has been shown to have a role in indexing attentional resources during an undemanding task (Polich 2007), and thus is widely used to obtain details regarding brain activity associated with attention.

2.4.1 P300

The P300 is one of the most studied ERPs, often associated with attention processes, that occurs within a time range of 250-350 ms. The peak latency of the P300 has been reported to occur as late as 400 ms.

2.4.1 a. The discovery of P300 and its correlation with updating of the mental 'schema'

The P300 waveform was discovered in 1965 by researchers studying ERPs corresponding to brain activity associated with a task that involved multiple stimuli with varying degree of familiarity and certainty about occurrence in a given amount of time (Sutton, S. et al., 1965). The experimental set up involved light and sound stimuli being presented to the participant at different time points. Sutton et al. observed major changes in a positive waveform appearing around 300 ms, which had a positive correlation with the uncertainty in anticipation of whether a light or sound stimulus would be presented and the correctness in anticipation of the same. Based on Sokolov's Orienting Response

model (Sokolov, E.N., 1990), it was deduced that the P300 waveform was associated with an individual's working memory when updating the mental model of the context or the individual's environment (Donchin, E. et al, 1986). This conclusion was inferred via experiments that showed that unless there was a change in stimulus presentation there was no change in the mental 'schema,' resulting in only sensory ERPs (Rushby et al, 2005).

2.4.1 b. P300 amplitude and latency: Its relation to attention

Event related potentials, such as the P300, are most often quantified or measured using two variables: 1) peak amplitude, i.e., the voltage displacement at the peak relative to the amplitude at onset; and 2) latency, i.e., the time point at which a waveform initially deviates from the baseline (termed onset latency); latency may also be measured relative to the peak amplitude (termed peak latency). These two features of the P300 waveform (amplitude and latency) have often been studied in conjunction with attention demanding tasks to study how behavioural attention affects the P300 waveform. Polich (1986) conducted a series of experiments to deduce factors that affect the latency of the P300. These investigations showed that changing the presentation probability of the target tone changed P300 amplitude but had little effect on P300 latency. The status of the participant (i.e., eyes open or eyes closed) did not have any significant effect on the P300 waveform variables. However, when the participant passively ignored the stimulus, a decreased P300 amplitude and increased latency (i.e., a delayed response) was observed. This study demonstrated how the P300 waveform and its characteristic features, like

amplitude and latency, are affected by behavioural experiments conducted in order to manipulate attention.

Many more experiments have been conducted to study the relationship of behavioural correlates of attention with the electrophysiological activity of the brain. An experiment by Kutas et al (1977) involved augmentation of mental chronometry by use of P300 as a measure of choice to study stimulus evaluation time. Five participants viewed a series of words. In the fixed name (FN) series, the name Nancy appeared on 20% trials and the name David on the remaining trials. In the variable name (VN) series, a random female name appeared on 20% of trials and the remaining trials constituted a random male name. In the third series, the synonym (SYN) series, synonyms of the word 'prod' appeared on 20% trials and other words on remaining trials. Each series was used for three different experimental conditions. Participants were required to either count the number of times the infrequent word from each series came up or they had to press one of two buttons depending on their stimulus category. Two choice reaction time conditions were employed, either speed reaction times (speed RT) or accurate reaction times (accurate RT). Upon ERP analysis, a large P300 ($>25\mu\text{V}$) was observed for the infrequent events. For the accurate RT condition, P300 latencies were higher for SYN followed by VN and then FN. However, for count-speed RT condition, VN and SYN had similar latencies but were both longer than FN. It was found that P300 latencies had higher correlation with reaction times on the accurate-RT tasks compared to their correlation with the reaction times on the speed-RT tasks and the correlation increased further when erred trials were removed from analysis (Figure 2). This finding supports the idea that

P300 latency is a sensitive measure of RT of both types. Results also suggested that accurate-RT was longer than the observed P300 latency because response selection and stimulus evaluation in this scenario were tightly coupled whereas speed-RT was more loosely related to P300 latency because there was a tendency to respond before stimulus evaluation.

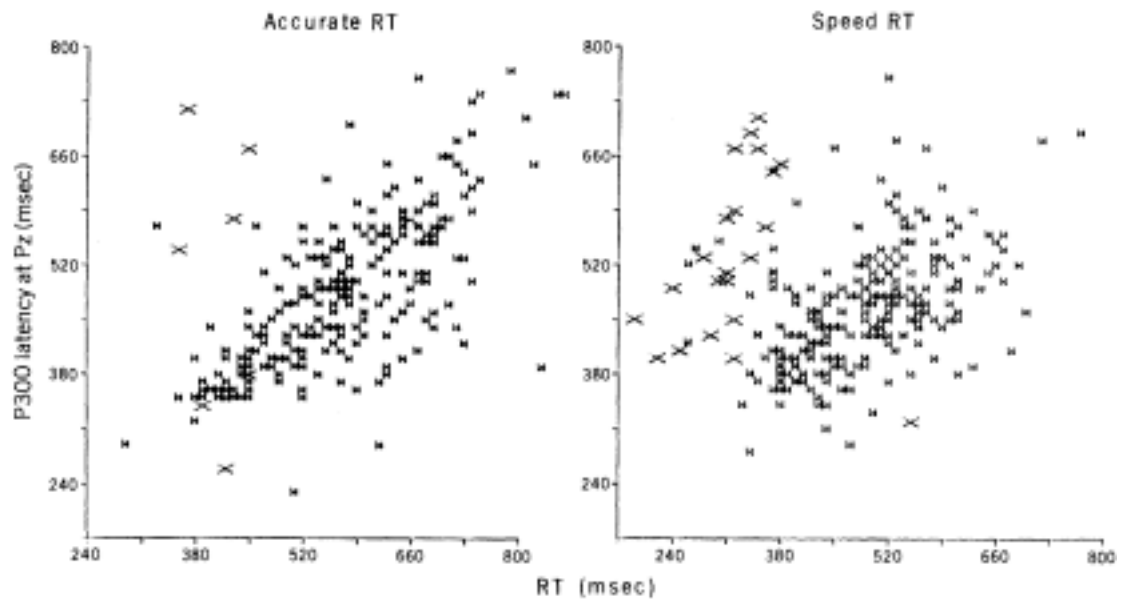

Figure 2: Graphs depicting statistical correlation ($r=0.66$ for accurate-RT and $r=0.48$ for speed-RT) between P300 latency and response time for the two choice reactions tasks (accurate and speed maximizing RT). Obtained from Kutas et al, 1977.

In another attempt to study how scores obtained by individuals on a task used for quantifying attention affect the latency of the P300 waveform, Braverman, E. et al (2006) collected data from 656 individuals (≥ 40 years of age) with clustered medical diagnoses and variable psychiatric diagnoses. The researchers tested the relationship of the participants' scores on the Test of Variables of Attention (TOVA) to the latencies of their individual P300 waveforms. TOVA is a neuropsychological assessment tool that tests the

behavioural aspect of attention by means of calculating response times and scoring individuals for severity of attention deficit and hyperactivity disorder. The results from the experiment showed that individuals (both males and females) identified as having significantly deviant or borderline attention failure on the TOVA (score < -1) had longer P300 latencies compared to the individuals with a normal TOVA score (score ≥ 0). These findings suggest that P300 is closely related to the behavioural changes in attention.

Similarly, a study by Strayer and Kramer (1990), revealed that the P300 amplitude reflected distribution/allocation of attention to task relevant procedures. Their participants performed a variant of the Sternberg memory search task which involves identifying the target letters (from a memory set of 1-4 letters) in 30 probe trials including trials with both non-target or at least one target letter. The participants also performed the recognition-running memory task in which the participants were presented with a series of digits and their task was to identify whether the digit on a given trial 'N' matched the digit on the trial 'N-2' (match trial) or not (mismatch trial). The tasks were presented either as a single task or together as a dual task (Figure 3). The investigators collected response times, a measure of sensitivity and P300 amplitudes. Participants were instructed to maximize their performance on either the Sternberg or running memory tasks or to emphasize the tasks equally. They noticed that larger P300 amplitudes were associated with target probes on the Sternberg task and the match trials on the Running memory task. The researchers also found that resource demands associated with the tasks depended upon the trade-offs in the amplitude of the P300 for each task. They inferred that P300 amplitudes reflected attention paid to a given task and the trade-offs reflected

differences in the distribution of attention between the tasks. The occurrence of P300s in conjunction with the task suggested the obligatory allocation of attention to task-relevant events during automatic processing, the nature of which was reflected by P300 amplitudes.

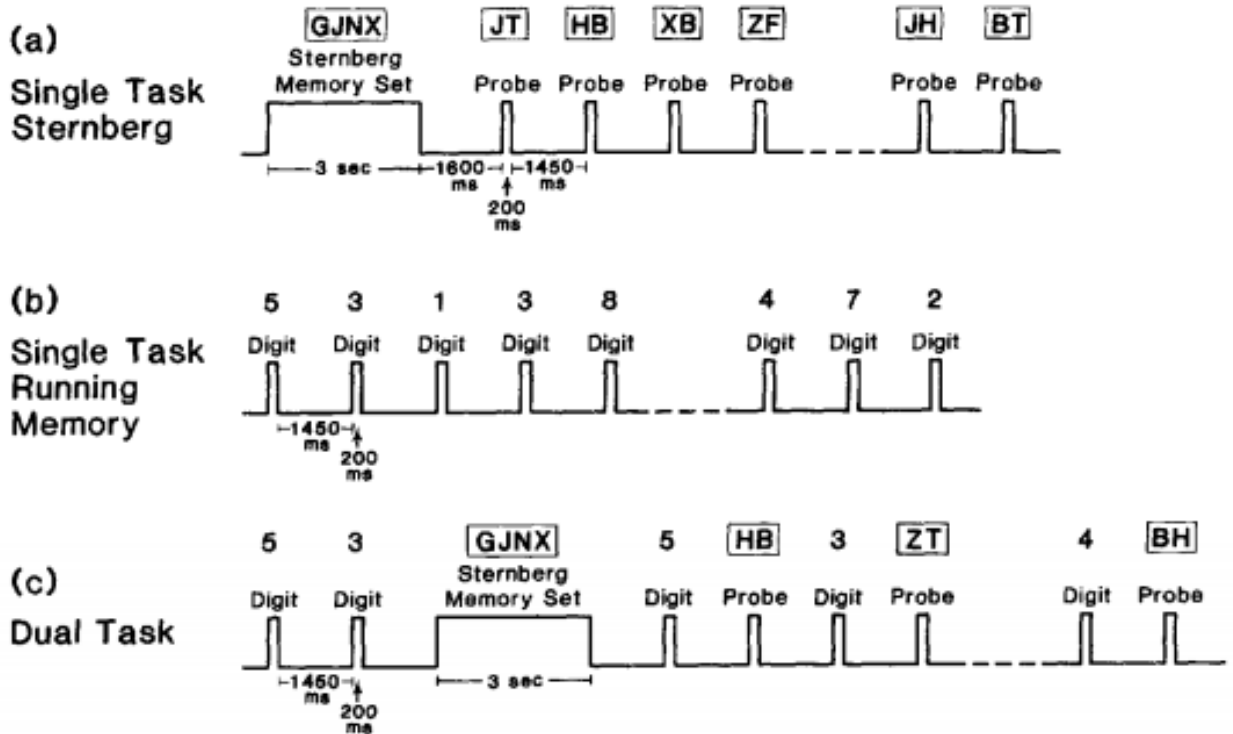

Figure 3: Illustration of tasks used for P300 analysis by Strayer and Kramer (1990) A.

represents the timeline of the Sternberg task when performed individually by the participant, B. represents the timeline of the running memory task when performed individually by the participant and C. represents the dual task condition where the participant performed a mix of trials of the Sternberg and running memory tasks.

Besides representing the allocation of attention towards a relevant task, Wickens et al (1983) were able to show that P300 amplitude also represented the amount of

attentional resources used by an individual to complete a given task. The researchers conducted a study through which they were able to infer that the P300 amplitude decreased with reduced need of resources for a task. Their participants performed a pursuit step-tracking task that involved pursuing a target with a cursor as it made random changes in its horizontal displacement every 3 s. The difficulty of the task was related to the change in direction of the displacement of the target and change in the action of the response key (joystick) i.e., at times moving the joystick moved the cursor at constant pace and other times it accelerated the cursor. Concurrently, the participants in the experimental group performed one of the three secondary tasks while a control group did not perform any secondary tasks. The secondary tasks included one of the following:

1. Auditory Probe: Participants heard a Bernoulli series of high and low pitched tones and were required to count all the low-pitched tones.
2. Visual Probe- Flash: A target flashed on a horizontal bar after every 100ms interval, with different intensities and the participants had to count the dimmer flashes.
3. Visual Probe- Step: This secondary task was embedded within the pursuit step-tracking task where an individual had to also count the number of displacements in a given direction during the pursuit step-tracking task.

Results showed that potentials associated with task relevant events increased in amplitude with an increase in demand of resources, whereas those elicited by secondary

tasks decreased. Since most resources were allocated for completion of the primary task, these results suggested that there was a reduction in the need to deploy resources for the secondary task. This reduction in need for resources was found to be associated with a reduction in the amplitude of the P300 elicited by the secondary tasks as well.

Another study was conducted to demonstrate the effect of aging on P300 and the attention of an individual. Emmerson et al (1989) studied 172 participants within an age range of 20-79 years to examine correlations between P300 latency, age and the Symbol Digit Modalities Test (SDMT). Age was found to correlate with increases in P300 latency, especially for participants with lower fitness levels, suggesting a slower information processing and execution of response to the SDMT. This result showed that P300 latency and SDMT performance were significantly correlated for older participants with low fitness levels. Such a relationship provided evidence that P300 latency is a measure of brain activity related to processing speed and performance associated with a behavioural task such as the SDMT. Thus, P300 latency provides a sensitive measure of age-related processes affecting the cognitive performance. Also, longer P300 latencies signify poorer mental function with longer cognitive processing speeds (Emmerson, R.Y. et al, 1989; Pelosi, L., et al, 1992a).

Polich and Herbst (2000) suggested that P300 is a very sensitive measure of attention allocation and immediate memory in temporal realms. Given how closely attention and working memory are related to P300, it is safe to assume that P300 can help quantify certain aspects of executive functions. P300, which was once considered to be a

unitary phenomenon, is now known to reflect several aspects of attention and working memory (Polich, 2007), which are key executive functions.

2.4.1 c. Components of P300: P3a and P3b

The P300 is comprised of two inter-related components. Since the P300 is associated with both attention allocation towards a stimulus and responding to it appropriately, it can be separated into the more “automatic processes (P3a) and the controlled processes (P3b)” (Stige, S. et al, 2007), suggesting that P3a is associated with allocation of attention and P3b with execution of the task or the process of responding. The automatic tendency to allocate attention or orient oneself to a change in context is a phenomenon defined purely by central processing of the change in context. The maintenance of context and relevant responding to the stimulus is a more voluntary processing of task relevant events, which is correlated to P3b during ERP analyses.

Although both are components of the P300, the P3a and P3b differ in their neural origins. Studies suggest that different areas of the brain are activated in response to events that specifically result in a P3a or a P3b waveform. While P3a has been observed in areas like cingulate gyrus, frontal and right parietal areas, P3b has mostly been observed in bilateral frontal, parietal, limbic, cingulate and temporo-occipital areas (Volpe, U. et al, 2007). Most of the analyses done to study the neural basis of P3a and P3b have been done by deductive reasoning from analyses of individuals with frontal lobe syndrome and dysexecutive syndrome. While the P3a shows a more frontal representation (i.e., the

amplitude is the highest in the frontal areas compared to parietal and occipital areas), P3b has larger amplitudes in parietal areas (Polich, J., 2007). Many ERP studies have shown that frontal lobe lesions have been found to affect the P3a the most (Daffner, K. et al, 2000a and 2000b,). Participants without frontal lobe lesions have been shown to spend potentially longer time attending to a novel stimulus (that elicits a P3a) than individuals with frontal lobe lesions who do not attend to novel stimulus (Daffner, K. et al 2000b). Similarly, functional magnetic resonance imaging (fMRI) studies have replicated the above noted findings. Kirino, E., et al (2000) performed an experiment where they had their participants perform a visual detection task while brain activity was recorded using fMRI. They observed greater activation in the prefrontal cortex during novel events suggesting that the frontal areas primarily help in attending to novelty. Many ERP and fMRI studies have been reviewed (Knight, R.T. et al, 1995, 1996, Opitz, B., 2003) together and they all point to the same results: fronto-central areas represent processing of novel events (i.e., would generate the P3a waveform), and parietal areas primarily represent target event processing (i.e., would generate the P3b waveform). It can also be inferred from these studies that a fronto-temporo-parietal circuitry guides the nature of P300 and its components (Polich, J. 2003).

2.4.1 d. Assessment of P3a and P3b: EEG and three-stimulus oddball paradigm.

The most commonly used paradigm for obtaining the P3a and P3b ERPs is the auditory oddball paradigm. The auditory oddball paradigm was first used by Squires et al (1975) to study different components of P3a and P3b. The study consisted of two different

experimental designs. In the first one, participants were presented with high and low intensity binaural tones and asked to either count high intensity tones or low intensity tones or ignore both and just read a book. In the second experiment, they heard high or low frequency tones and were supposed to count either the high or low frequency tones or ignore them entirely. Squires and colleagues noted two distinct late positive components on EEG analyses of which the earlier one (P3a) occurred at instances when there was an infrequent unpredictable shift in either intensity or frequency of tones occurring during the 'ignore' phase and the later component (P3b) occurring when the participant was actively attending to the stimuli. Subsequently, Polich and colleagues performed experiments involving the oddball task to study the P300 and its components. In a review regarding the nature of the P300 and its application, Polich (2007) described the tasks and their associated ERPs (Figure 4). Briefly, attention is basically a process involving stimulus evaluation and execution of response. Thus, an individual first attends to the event, evaluates it and then responds or ignores appropriately. The P300 reflects this process. This combined waveform is generated when individuals perform the single stimulus task where every time they see a target, they are supposed to respond using a button press or counting. If a second stimulus (two stimulus oddball task) is added to this task and the individuals are instructed to ignore the second stimulus, then a larger P300 waveform is obtained due to greater allocation of attention-inhibition processes. However, if a third stimulus that is infrequent and new (i.e., the individuals are not expecting this stimulus), the combined waveform (P300) is split giving an earlier P3a that represents evaluation of the novel stimulus, and the later P3b that represents evaluation of the target stimulus. This latter task is referred to as the three stimulus oddball.

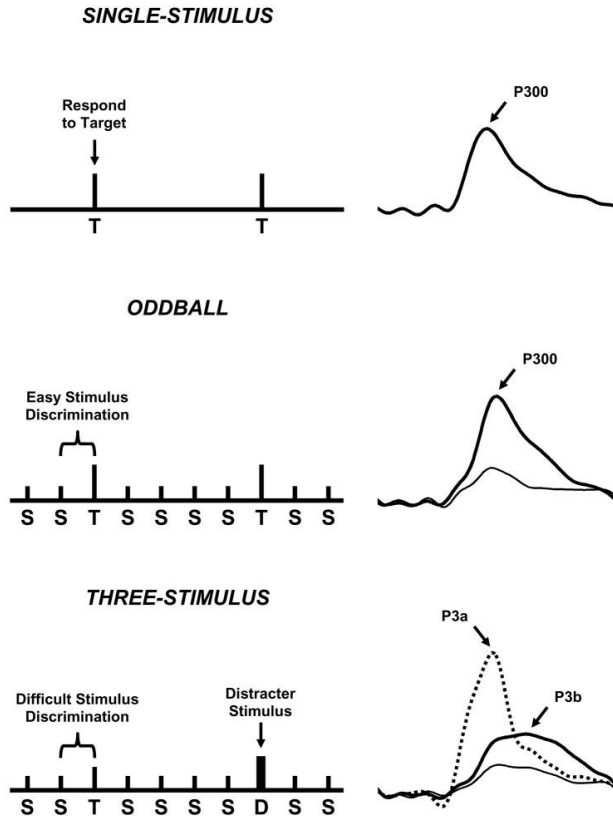

Figure 4. Different tasks performed to obtain different components of P300: The topmost panel shows the occurrence of a P300 waveform with every response to a target stimulus (T). The middle panel shows a two-stimulus oddball task where a P300 waveform occurs at the time point when the participants respond to the infrequent target stimulus (T). The bottom panel shows the three-stimulus oddball task where a disintegration of the components of P300 waveform (P3a and P3b) is shown to be associated with an infrequent distractor stimulus that the participants did not anticipate. Obtained from Polich (2007)

2.4.1 e. The Changing face of the oddball task in the study of P3a and P3b

Since the mid 1970's, many researchers have assessed the P3a and P3b components separately to analyse the neural and behavioural differences between them. For this purpose many variations of the classic auditory oddball paradigm have been designed and utilized. More recently, researchers have tried assessing the auditory paradigm against a visual paradigm, or manipulated task features like strength of the stimulus discrimination and the novelty of the distractor stimuli. Such a variety of combinations has led to development of many forms of oddball paradigms, each evoking a different neural response. One common feature, however, has been the pattern of the paradigm. It consists of standard frequent stimuli, target infrequent stimuli to which the participant responds, and the third distractor stimulus that is infrequent and unexpected. A block of mixed trials of this nature is used to test an individual's attention. Simultaneous EEG recordings permit ERPs to be obtained (i.e., the P3a and P3b).

It is known that P300 amplitude varies with improbability of the stimulus and that the latency of the response depends on strength of stimulus discrimination (Picton, T.W., 1992). A study by Comerchero and Polich (1998) demonstrated that non-target (i.e., trials for which there is no response) P3a amplitude was larger and earlier than the target (i.e., trials that are followed by a response) P300. Larger P3a was found to be associated with auditory stimuli, compared to the visual stimuli. Additionally, greater difficulty in discriminating between the target and non-target stimuli resulted in a larger P3a response.

Another study by İsoğlu-Alkaç, Ü. et al (2007) demonstrated how using a mixed modality of stimuli resulted in different and larger neural responses to the classical oddball paradigm. Due to such variations in the paradigms used to test attention allocation and task relevant responses there is little consistency among investigators of the cognitive domain. Despite studying various modifications of the oddball task, there are still some discrepancies among researchers whether one modification is better or worse than the other. Additionally, researchers have mostly not deviated from the type of task (i.e., oddball task) they have used to study attention and hence, there has been little exploration of the same. Thus, as much as it is important to design one task that fulfills all requirements of providing the most appropriate results which includes a larger and measurable change in electrical activity obtained via the EEG that corresponds to the attentional processes, it is also important to explore new paradigms to obtain the same.

2.5 Flanker task- Exploring attention and inhibition

The Flanker task, designed by Eriksen and Eriksen (1974), is a neuropsychological test widely used to study behavioural aspects of attention and inhibition. This task involves visual searching and allocation of attention towards the central figure to respond correctly. The original test comprised a task in which one of six conditions (as shown in Table 1) was displayed on a screen after the presentation of a fixation cross. The participants were instructed to use a right and left lever key to respond, pressing either of the keys when H or K appeared as the letters in the center and the opposite key when S or C appeared in the center. The ‘noise’ (i.e., the stimuli that act

as distractors to the target stimulus) was provided by the letters flanking (situated adjacent to) the target letter in the center. Through this experiment Eriksen and Eriksen were able to demonstrate evidence of a preparatory set within the participants that helped them inhibit the noise while responding. This finding indicated that the participants demonstrated the presence of a system of preparatory allocation of attention as part of stimulus evaluation. This system is what enabled the participants to inhibit irrelevant noise and hence attend to the target stimulus. Eriksen and Eriksen were also able to show a significant decrease in reaction times of individuals when the noise or the flanking letters were of the opposite response set, also known as an incongruent trial. Moreover, response times were slower for closely spaced letters as the discrimination decreased between the target and noise which meant that participants spent greater time trying to figure out the difference between target and noise in order to respond accurately. This finding suggests that the participants' attentional process was delayed if the difficulty in discriminating between the two stimuli was increased. Since these initial studies, the Flanker task and many of its variants have been used to assess specifics of attention.

Table 1. Task conditions for the Flanker. Reproduced from Eriksen and Eriksen (1974)

<u>Condition</u>	<u>Example</u>
1. Noise same as Target	H H H <i>H</i> H H H
2. Noise Response Compatible	K K K <i>H</i> K K K
3. Noise Response Incompatible	S S S <i>H</i> S S S
4. Noise Heterogenous- Similar	N W Z <i>H</i> N W Z
5. Noise Heterogenous- Dissimilar	G J Q <i>H</i> G J Q
6. Target alone	<i>H</i>

In a study aimed at assessing the role of emotion and facial features in attention (Fenske and Eastwood, 2003), participants were given the task of identifying emotionally expressive target faces, a variant of the original Flanker task. It was found that participants were able to identify the targets better when flanked with a similar emotionally expressive face than with an incompatible face. A similar flanking compatibility was observed when the emotional expression was distorted but many facial features were retained in the flanked faces suggesting a constriction of attention based on facial expression and emotion. This finding suggested that familiarity (to facial features or emotion) acts as a variable in describing attentional processes. As long as the target and flanking faces had distorted expressions but similar facial features or different facial features but similar expressions, the participants were able to attend better to these situations than to situations with dissimilarity in these variables. Such variations of the Flanker task have often been employed to assess attention; however, attentional processes have primarily been assessed via behavioural measures (e.g., error rates and reaction times). Some studies have successfully used the Flanker task to obtain and assess the P300 waveform to quantify attention. For instance, in a study by Pratt, N. et al 2011, it was found that increasing the working memory load in a task resulted in a change in the P300 amplitude as well as the reaction times of the participants. In one setting, the participants performed a single task condition where they completed a Flanker task with target trials (right or left facing arrows). The participants were supposed to respond to each stimulus. There were trials where the target arrow was in the same direction as the flanking arrows (termed congruent trials), and trials where the target arrow was in the

opposite direction of the flanking arrows (termed incongruent trials). In another setting, participants performed a dual task condition where they completed the Flanker task along with a Sternberg memory task (as explained earlier in section 2.4.1b). The results showed that the Flanker task successfully generated a P300 waveform in response to the target trials. The amplitude of the P300 decreased with increasing load of task performance (i.e., greater set size, greater number of Flankers or incongruent trials, as well as in the dual task condition; Figure 5).

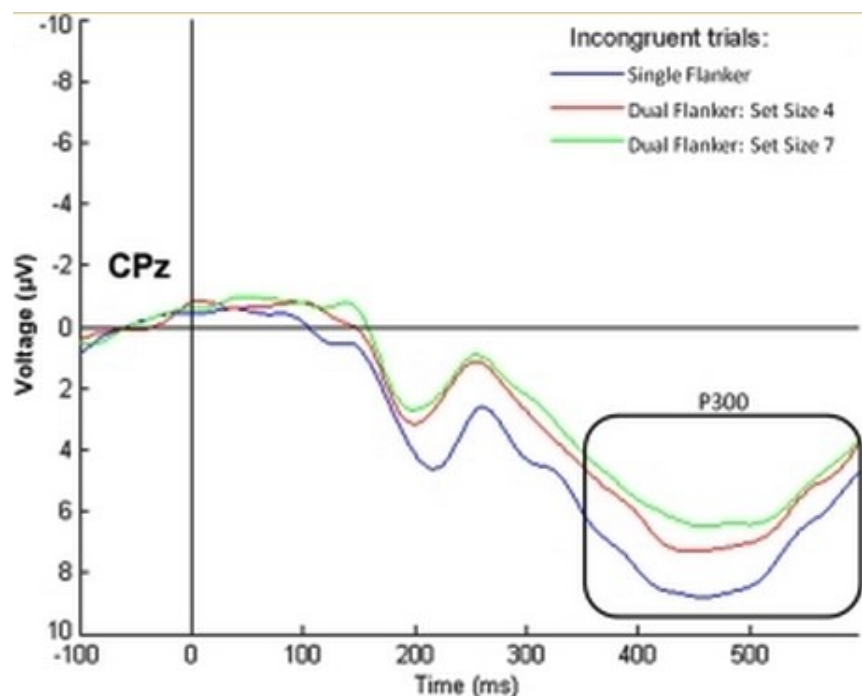

Figure 5. P300 analysis in single task (Flanker task) and dual task (Flanker+Sternberg task) conditions (obtained from Pratt, N. et al, 2011). The Flanker task and dual task condition provided a clearly distinguishable P300 waveforms. It is clear that P300 amplitude decreases with increasing task difficulty (inset box, green line representing dual Flanker task with a set size of 7, compared to the red line representing dual Flanker

task with a smaller set size of 4 and the blue line representing single Flanker task respectively).

In addition to the assessment of attentional process (both novel and task driven), the Flanker task assesses response inhibition i.e., the ability to suppress irrelevant responses to stimuli. According to MacLeod, C. (2007), cognitive inhibition is the ability of the human brain to tune out irrelevant stimuli from the environment. Mental processing for a given task involves an alternating sequence of states of distraction or attention. To improve focus and for greater attention, it is important to rule out distractions from the environment. This also promotes efficiency of mental processing by ruling out the need to spend mental resources in evaluating irrelevant stimuli. A situations such as this is where cognitive inhibition plays a role. The Flanker is a task that addresses both of these processes. While an individual attends to the target stimulus, he/she has to tune out distractions from the Flankers for accurate responses.

In summary, the Flanker task is useful for obtaining both behavioural and electrophysiological measures of attention, and that this task represents the mental processing involved with both attention and inhibition processes. To our knowledge, no studies have demonstrated whether a Flanker task can be used to obtain the P3a, or the measure of novel attention, separate from the P3b, which is a measure of attention and response execution. If it is possible to devise a modification to this task by adding an infrequent novel stimulus, it could be possible to assess the purely attentional component

of the stimulus evaluation (the P3a waveform) distinctly from the combination of stimulus evaluation and response (the P3b waveform).

This project was aimed towards devising a modified Flanker task that can be compared to the three-stimulus auditory oddball paradigm to assess whether it is similar to, better, or worse, than the oddball task as a means to quantify the P3a and P3b. To this end, we designed two modified paradigms with the intent to obtain better stimulus distinction than the auditory three-stimulus oddball paradigm. The new paradigms consisted of modifications to the Eriksen Flanker task. We modelled our modifications of the Flanker task design using the Flanker task that has been employed by Ridderinkhof, K.R. et al (1999). Instead of the original letters system, we added infrequent novel stimuli of auditory or visual nature in each of the Flanker task modifications and called these paradigms a mixed modality (visual and auditory) and single modality (visual only) Flanker tasks. We used two different stimulus modalities for our designs to study the effect of stimulus modality and its distinction from the target on the P3a and P3b. The complete procedure, task details and results are described in the following sections.

CHAPTER 3: OBJECTIVES AND HYPOTHESIS

3.1 Objectives

Towards the goal of devising a task to differentiate the P3a from the P3b, the objectives include:

1. To devise two modifications of the Flanker task for quantitative analysis of attention in young, non-disabled individuals.
2. To assess brain activity associated with novel attentional processes distinctively from attentional processes that are followed by execution of a response, i.e., analysis of the P3a and P3b waveforms, respectively.
3. To compare amplitudes of the P3a and P3b elicited by the modified Flanker task and the auditory three-stimulus oddball task.
4. To examine the relationship between reaction time and P3a and P3b latencies obtained from the modified tasks and the auditory three-stimulus oddball task.
5. To assess whether the use of single modality or mixed modality stimuli in the modified Flanker task results in more distinct P3a and P3b as assessed by its amplitude.

3.2 Hypotheses

1. The modified Flanker task will provide electrophysiological data relevant to the assessment of attention (P300 and P3a and P3b components) young, non-disabled individuals.

2. Electrophysiological data relating to performance on the modified Flanker task will clearly demarcate novel attentional processes from attentional processes associated with task relevant response by providing a basis for obtaining and analysing the P3a and P3b components of the P300.
3. The modified Flanker tasks will provide more distinct P3a and P3b compared to the P3a and P3b obtained from the three stimulus oddball task, as evidenced by increased amplitude of the P3a and P3b responses from the modified Flanker task.
4. Both the P3a and P3b latencies will have a high correlation with response times obtained within each task and the correlation will be greater for the modified Flanker tasks compared to the correlation obtained for the auditory three stimulus oddball task
5. The modified Flanker task with mixed modality stimuli will quantify attention better by providing larger and more distinct (in the time domain) P3a and P3b compared to the same modality stimuli task.

CHAPTER 4: METHODS

4.1 Participants

4.1.1 Inclusion and exclusion of participants

Participants consisted of non-disabled young adults. There is evidence of significant changes in orienting of attention with age and that adult-related attention behaviours start within the age range of 16-21 years (Waszak, F. et al, 2010). In a meta-analysis of normative aging and effects on the P300, Polich (1996) reported that changes in latency and amplitude of the P300 are related to age. Of the different groups studied, the group within the 20-29 year age range showed similar P300 characteristics and higher P300 amplitude, which were significantly different from other age bins (Figure 6.) Additionally, another study compared groups of individuals 18-33 years of age (young adults) with individuals 65-80 years of age (older adults). The study results suggested that there is a significant decline in attentional processes between the groups with poorer attention for older adults' group (Brent, G. et al, 1977). Owing to this evidence, non-disabled young adults were selected within the age range of 19-29 years. Another meta-analysis by Jeon and Polich (2003) showed that the selected age group demonstrated P300 amplitudes and latencies with excellent effect sizes as shown in Figure 7. Larger effect sizes suggest that the given age group represent more robust changes in electrophysiological variables of attention.

Jeon and Polich (2003) also showed a correlation between effect sizes for P300 amplitude and latency with different sample sizes (Figure 8.). The graphs show that a relatively good effect size can be seen for analysis of P300 amplitude and latency at a sample size of 40-50. Thus, for our study a total of 40 participants were recruited, owing to evidence of good effect size for that sample size balanced with feasibility of recruitment. Participants for this project were selected based on the criteria that they did not have any prior neurological injury, psychiatric illness, or self-reported and/or clinically diagnosed psychological problems based on a screening form (Appendix 1).

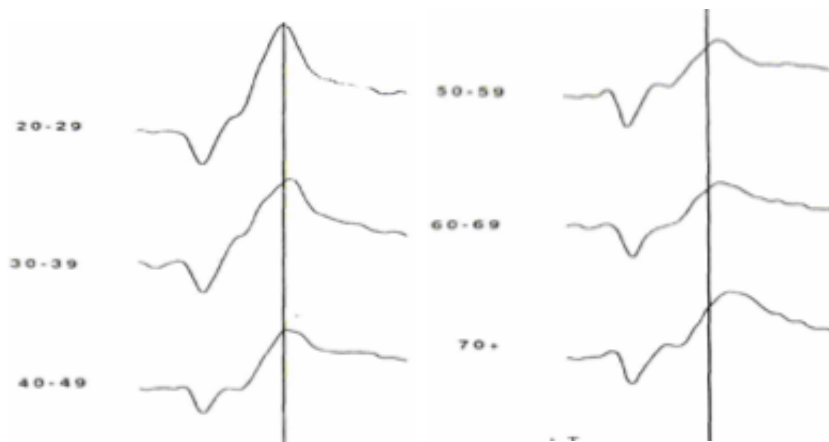

Figure 6. The panel on the left clearly shows the larger P300 amplitude for the 20-29 years age bin compared to others. Obtained from Polich (1996) (X-axis: Latency (ms); Y-axis: Age (years))

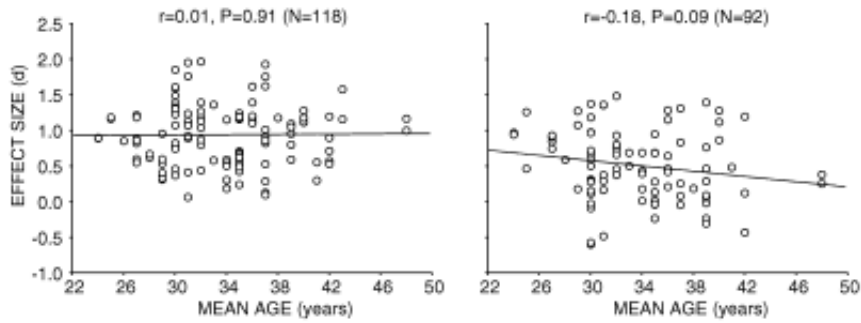

Figure 7. Effect size analysis of P300 amplitude (left panel) and, P300 latency (right) with respect to mean age. Larger effect size is shown (close to 1) for younger adults (left-most part of the graph) in case of P300 latency while no difference is observed for P300 amplitude when compared to older adults. Larger effect sizes suggest that the changes seen in the younger adult age group holds more strength and are more applicable than results that have smaller effect sizes. Obtained from Jeon and Polich (2003)

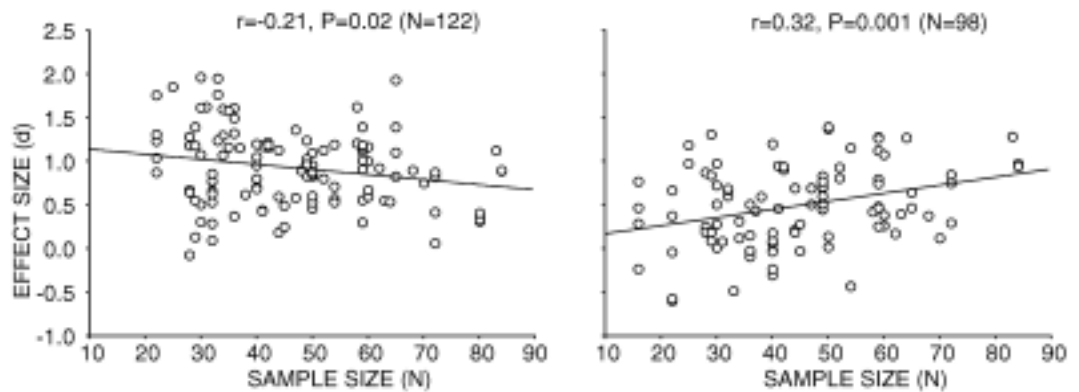

Figure 8. Effect size analysis of P300 amplitude (left) and P300 latency (right) with respect to sample size. Obtained from Jeon and Polich (2003)

4.1.2 Participant recruitment

Prior to recruitment, the research protocol was approved by the Research Ethics Board of the Capital District Health Authority. Participant recruitment was done via word of mouth.

4.2 Measures for Collecting Baseline Participant Characteristics

4.2.1 Screening Form

Information regarding age and sex was obtained verbally from the participants. Further details regarding inclusion in the study were clearly mentioned on a form (Appendix 1). A participant code was provided.

4.2.2 Edinburgh Handedness Questionnaire

Handedness of the participants was determined by the Edinburgh Handedness Questionnaire (Oldfield, R.C., 1971) (Appendix 2).

4.3 Experimental design

The study included a single experimental session where each participant performed three tasks: the oddball task, the mixed modality Flanker task, and the single

modality Flanker task. Each experimental session lasted a maximum of 2 hours, including rest periods for the participants.

4.3.1 Tasks

The tasks were designed using Python (v.2.6.6). A command within the code was used to obtain details about behavioural measures of attention, i.e., error rate and reaction times, along with details about participant ID and the task being performed. The software was also coded to relay numeric event triggers to the EEG system. These triggers denoted trial onset, type of stimuli, and type of response. The tasks performed were as follows:

A. Modified Flanker Task- Single modality stimuli (Figure 9)

This task included 5 blocks of 40 trials each with three types of stimuli for a total of 200 trials in one task. Twenty percent of the trials were the target stimulus trials that consisted of presentation of an array of five white arrows pointing to the left or right. The trials with all arrows pointing in the same direction were termed congruent trials and the trials with the central arrow pointing in the opposite direction to the flanking arrows were termed incongruent trials. The participant was told to respond by pressing the right or left cursor key on the keyboard based on what direction the central arrow was pointing (e.g., if the arrow pointed right, the participant would press the right cursor key). Seventy percent of the trials were the standard stimulus trials that consisted of presentation of an array of five arrows, three of which were white while the ones on either end were yellow.

The participant was aware of these trials and was told not to respond to them. The remaining trials (ten percent) were the distractor stimulus. Distractor stimuli were visual in nature, which included presentation of white and yellow arrows, as in case of standard stimulus. The only difference was that the central arrow was replaced by the image of an object. Participants were not made aware of these distractor trials. The images used as distractors were obtained from Google images and were filtered to include only images with a black background since the main screen of our experiment was black in colour and thus participants would focus only exclusively on the image.

B. Modified Flanker Task- Multiple modality stimuli (Figure 9)

This task included 5 blocks of 40 trials each with three types of stimuli amounting to a total of 200 trials in one task. Twenty percent of the trials were the target stimulus trials and seventy percent of the trials were the standard stimulus trials same as described above. The participant was aware of these trials and responded appropriately. The remaining trials (ten percent) were the distractor stimulus. The distractor stimuli were auditory in nature, which included presentation of white and yellow arrows, as in the case of standard stimulus. The only difference was that along with the visual presentation, a 1s sound clip of a recognizable sound like laughter, sneeze, dog bark etc. was played. Participants were not made aware of these trials. The sound clips used as distractors were obtained from www.soundbible.com and www.findsounds.com. These sound clips were restricted to 1s in length. Open source software (Audacity v2.0.5) was

used to ensure the sound clips had the same loudness and rise time (50ms). Additional software (MP3gain v1.2.5) was used to normalize the gain across sound clips.

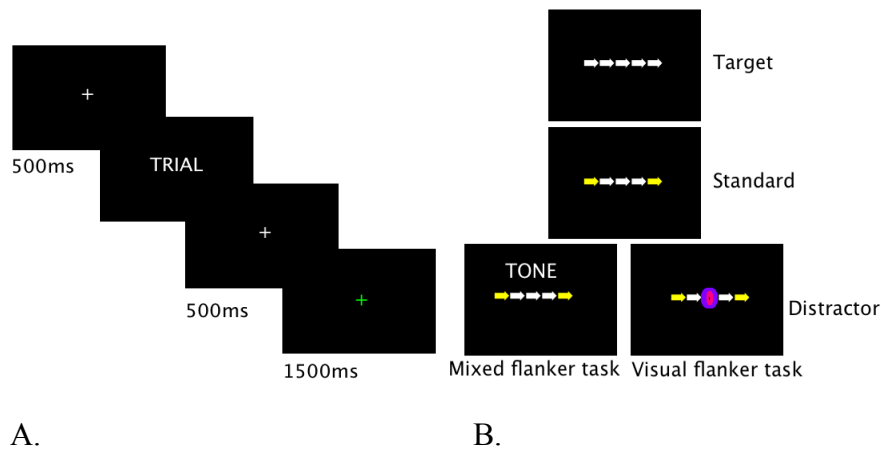

Figure 9. Modified Flanker tasks used for assessment of attention included the mixed Flanker task (visual and auditory stimuli) and the visual Flanker task. A. Single trial timeline B. Task specific stimuli

C. Three-stimulus Auditory Oddball Task (Figure 10)

This task was adapted from Comerchero and Polich (1998, 1999). Ten percent of the trials included target stimuli that were 2000 Hz tones. The participant was told to respond to the target stimuli by pressing ‘Space bar’ on the keyboard. Eighty percent of the trials were standard stimuli trials comprised of 1000 Hz tones for which the participant was not required to respond. The remaining trials (ten percent) were distractor trials that were 500 Hz tones.

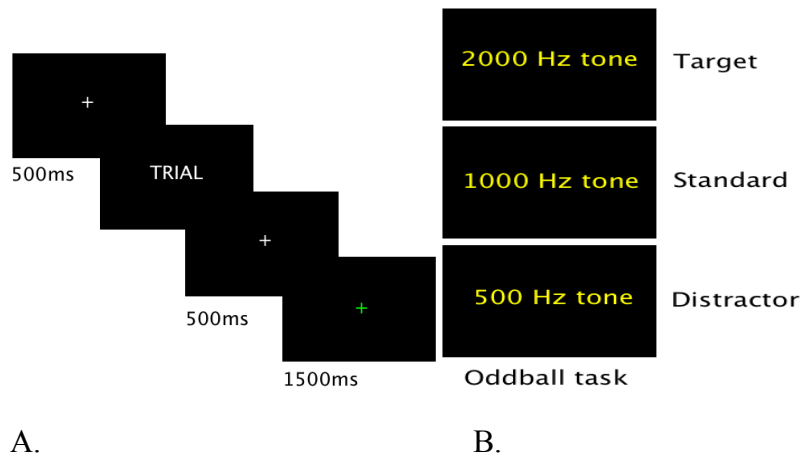

Figure 10. Three-stimulus auditory oddball task used for assessment of attention. A. Single trial timeline B. Task specific stimuli

4.3.2 Experimental set up

Participants were seated in front of a 42” LCD screen that was placed at a distance of 136 cm from the participant. The participants were then asked to perform the three tasks (as described above) presented on the screen for the assessment of attention. The tasks were run using a computer with Intel® Core™ i3-3720 CPU @3.30 GHz and the Microsoft Windows XP Professional (2002) system. The tasks were displayed on the 42” screen. Participants were also prepared for collecting EEG and the electrooculogram (EOG) data simultaneous to task performance. The EEG and EOG data were recorded using Curry 7 (Neuroscan, Compumedics USA, NC) on an Asus K55VD with Intel® Core™ i7 processor, 3610 CPU @2.3 GHz. Data was obtained using a QuickCap64 with 64 channels at a sampling rate of 1000 Hz and a bandpass of DC to 300 Hz. The EOG was collected using 4 electrodes placed around the eyes of the participant, to monitor any eye movements that may pose as a potential artefact during data analysis. Two free

electrodes placed on the mastoid process (left and right) were used as reference electrodes.

4.4 Procedure

4.4.1 Randomization of order

Each participant was tested on three different tasks in a single session. To minimize the effect of order, the participants were randomized into one of six groups with different order of task performance (Table 2). Participants were randomized to these groups sequentially in the order of recruitment.

Table 2. Groups for participant randomization

Group Number	Task Order
1	OB, MM, SM
2	MM, SM, OB
3	SM, OB, MM
4	OB, SM, MM
5	SM, MM, OB
6	MM, OB, SM

OB = auditory three stimulus oddball task; SM = single modality Flanker task; MM = mixed modality Flanker task

4.4.2 Orientation Sessions

The orientation of the participants selected for the study was carried out in a short 30-minute session on the day the participant was scheduled for data acquisition. The researcher explained the purpose and procedure of the study to the participant and obtained written consent (Appendix 3) from the participant. Required demographic information was obtained on a personal background information form (Appendix 4).

4.4.3 EEG Preparation

The process of EEG preparation was described to the participant and any queries and concerns were answered. After the instructions, the participant was prepared for EEG data collection. This involved using an exfoliating gel (NuPrep) and alcohol swabs to clean and abrade specific areas on the face (vertically above and below the left eye and lateral to both the eyes) and behind the ears on bilateral mastoid process to reduce skin impedance by removing skin oils, dirt and dead skin cells. Free electrodes were placed around the eyes (above and below the right eye and laterally to both the eyes) and on the mastoid processes on both sides using adhesive ring electrodes.

Measurements of the distance from the nasion to inion, and between each tragus was taken. Intersection of these distances at their midpoints gave us the position of the Cz electrode on the EEG cap. A 64 channel Quick cap (Neuroscan, Compumedics USA, NC)

with a 10-20 system of electrode position (Towle, Vernon L. et al 1993) was used. After putting on the cap, it was connected to a SynampsRT/model 9302 amplifier (Neuroscan, Compumedics USA, NCNeuroscan, Compumedics USA, NC). A syringe with a blunt tip was used to insert conductive gel in the electrodes to achieve scalp impedances \leq 5kOhms.

4.4.4 Experiment

Once the participants were prepared for EEG data collection, the participants were described the first task, the types of target and standard stimuli to expect and appropriate response keys, using a standard script. They were allowed to practice 1 block of the task with 10 trials prior to beginning the experiment.

After the practice, the participant was asked to start the experiment and call the investigator at the conclusion of the task. The same process was repeated for the second and third tasks. Participants were provided 30 seconds break between blocks of the experiment. At the conclusion of the third task, the experiment ended.

4.5 Analysis

4.5.1 Behavioural analyses

Behavioural analysis included calculation of the error rate by counting the number of incorrectly answered congruent or incongruent target trials plus the number of responses made to standard stimulus. Mean reaction times (i.e., response times to target stimuli) were calculated as the interval between stimulus presentation and the response made by the participant for the target trials in all three tasks.

Mean reaction times were compared for individual participants between the three task conditions. An analysis of variance (ANOVA) was used to analyze the differences in the mean reaction times obtained for the 40 participants in all three task conditions. Paired *t*-tests were used to compare reaction times for congruent and incongruent trials of the mixed Flanker tasks. Statistical analyses were conducted using the 'Data Analysis Add-In toolpak' in Microsoft Excel 2013, and Minitab v16.0, with an a priori alpha value of $p < 0.05$ denoting significance.

Percentage error was calculated for congruent and incongruent target trials in the mixed and single modality Flanker tasks and compared. Percentage error was represented as the percentage of number of incorrect responses out of total responses.

4.5.2 Electrophysiological analyses

4.5.2 a Pre-processing

Analysis of EEG data was done using Curry 7 software (Neuroscan Imaging Suite, Compumedics USA, NC). Using the event triggers denoting the beginning of each trial, the continuous EEG waveform was reduced into 550 ms epochs (100 ms pre- and 450 ms post-stimulus). Epochs were baseline corrected using a 100 ms interval before the stimulus. The data were then bandpass filtered (0.1-30 Hz) (Bougrain, L. et al, 2012, Polich, 2003). Individual epochs were visually inspected for associated EOG and blink artefacts, and if present removed using the proprietary software available within Curry 7. Trials with other artifacts (e.g., jaw clenching, yawning etc.) and blink artefacts that could not be reduced using the software were removed from analysis.

4.5.2b Event-related epochs and individual averages

Events of interest were averaged within participants using the event triggers to derive the ERPs of interest. For the mixed Flanker tasks we combined the EEG data obtained for correctly answered incongruent and congruent target trials for further analysis of the P3b waveform. Similarly, for the three-stimulus oddball task, epochs were obtained for target trials with no error in response for further analysis of P3b waveform. We also obtained epochs for standard trials on all the three tasks. Additionally, to analyse

novel attention, EEG data corresponding to distractor trials were obtained separately for all the three tasks in order to obtain the P3a waveform.

The individual averaged data was used to mark maximum and minimum peaks, as well as onset latencies for each subject. These values were then exported to Microsoft Excel 2013 to obtain peak amplitude and latency values for the waveforms of interest.

4.5.2c Group averaging

Group averaging was done by averaging the individual data averages obtained for the event codes of interest as described in section 4.2.2b. The values of the group averages were imported into Microsoft Excel 2013. Data of interest from Fz, Cz and Pz electrodes were selected and graphs were plotted using Graphpad Prism v4.0 for qualitative analysis of the ERPs obtained for the three tasks at the different electrode sites.

CHAPTER 5: RESULTS

Forty non-disabled adult participants (23.6 [range 19-28] years; 13 females) participated in the study. Of the forty participants, thirty-five were right-handed, two were left-handed and three were ambidextrous. All participants completed each of the three tasks. Data from one participant for the three-stimulus oddball task were omitted from analysis due to a mismatch in the number of active electrodes used during data acquisition. Thus the ERP data analysed for the oddball task included 39 participants.

5.1 Reaction time and error

For the modified Flanker tasks, average reaction times were obtained for the congruent and incongruent trials separately. For the oddball task, the average was calculated using the reaction time data for the target trials. Only trials that were attended to accurately were selected for this analysis. The average reaction times for each participant can be seen in Table 3. The overall average reaction time for the participants was 1.030 ± 0.156 s for the oddball task, 0.608 ± 0.077 and 0.608 ± 0.076 s for the congruent and incongruent trials of the single modality Flanker task, respectively, and 0.603 ± 0.071 s and 0.603 ± 0.073 s for the congruent and incongruent trials of the mixed modality Flanker task, respectively.

Table3. Average reaction time (RT; seconds) for all forty participants on the target trials of the single modality Flanker, mixed modality Flanker and the oddball task.

Participant number	Mixed modality Flanker task- Congruent	Mixed modality Flanker task- Incongruent	Single modality Flanker task- Congruent	Single modality Flanker task- Incongruent	Oddball
1	0.644	0.643	0.544	0.542	0.908
2	0.655	0.656	0.545	0.546	1.034
3	0.593	0.595	0.59	0.59	1.014
4	0.562	0.563	0.533	0.533	1.083
5	0.543	0.541	0.664	0.664	0.959
6	0.59	0.589	0.603	0.604	0.906
7	0.644	0.647	0.723	0.722	1.213
8	0.694	0.695	0.576	0.578	1.371
9	0.596	0.599	0.665	0.667	0.988
10	0.625	0.624	0.527	0.528	0.910
11	0.625	0.624	0.704	0.703	0.878
12	0.492	0.491	0.535	0.537	0.825
13	0.672	0.671	0.684	0.683	1.189

Participant number	Mixed modality Flanker task-Congruent	Mixed modality Flanker task-Incongruent	Single modality Flanker task-Congruent	Single modality Flanker task-Incongruent	Oddball
14	0.664	0.665	0.571	0.572	1.134
15	0.772	0.773	0.499	0.501	1.392
16	0.475	0.474	0.869	0.867	0.895
17	0.589	0.59	0.561	0.563	0.869
18	0.563	0.562	0.593	0.594	0.959
19	0.633	0.634	0.731	0.725	1.197
20	0.535	0.533	0.609	0.609	0.920
21	0.607	0.609	0.581	0.581	0.805
22	0.675	0.68	0.556	0.556	1.033
23	0.595	0.595	0.579	0.579	0.958
24	0.58	0.57	0.61	0.61	1.410
25	0.54	0.55	0.61	0.61	1.130
26	0.54	0.54	0.57	0.57	1.100
27	0.61	0.61	0.51	0.51	0.890
28	0.51	0.51	0.52	0.53	1.050

Participant number	Mixed modality Flanker task-Congruent	Mixed modality Flanker task-Incongruent	Single modality Flanker task-Congruent	Single modality Flanker task-Incongruent	Oddball
29	0.699	0.701	0.651	0.652	1.298
30	0.477	0.477	0.557	0.556	0.919
31	0.587	0.586	0.625	0.622	1.060
32	0.502	0.501	0.547	0.548	0.934
33	0.612	0.616	0.595	0.597	1.011
34	0.507	0.505	0.556	0.559	0.958
35	0.572	0.573	0.574	0.575	0.882
36	0.624	0.626	0.66	0.662	1.005
37	0.772	0.772	0.764	0.766	0.942
38	0.594	0.593	0.584	0.585	0.989
39	0.703	0.705	0.672	0.673	0.952
40	0.629	0.627	0.676	0.647	1.242
Mean RT (s)	0.603	0.603	0.608	0.608	1.030
Standard Deviation(s)	0.071	0.073	0.077	0.076	0.156
95% Confidence Interval(s)	0.581-0.625	0.580-0.626	0.584-0.632	0.584-0.632	0.908-1.204

Statistical analysis of reaction times showed that there was no significant difference in the reaction times between congruent and incongruent trials for the mixed modality Flanker task ($t = -0.7863$, $p = 0.22$, $\alpha = 0.05$) or the single modality Flanker task ($t = 0.2135$, $p = 0.42$). Also, reaction times for congruent trials of the mixed and single modality Flanker tasks ($t = -0.3529$, $p = 0.22$) and incongruent trials of the mixed and single modality Flanker tasks ($t = -0.3206$, $p = 0.22$) were not significantly different.

Single factor ANOVA was conducted to compare reaction times on congruent trials of the modified Flanker tasks and the target trials of the oddball task. It was found that there is a significant effect of participant ($F = 1.6326$, $p = 0.0335$) and task condition ($F = 247.6306$, $p = 1.64414E-34$) on the reaction time. Similarly, single factor ANOVA was conducted to compare reaction times on incongruent trials of the modified Flanker tasks and the oddball targets. As with congruent trials, there was a significant effect of participant ($F = 1.6070$, $p = 0.0382$) and task condition ($F = 246.6682$, $p = 1.87457E-34$) on the reaction time.

Table 4: ANOVA results for reaction times on the congruent trials of both the modified Flanker tasks and the oddball task

Source of Variation	SS	df	MS	F	P-value	F critical
Participant	0.619334533	39	0.015880373	1.632649159	0.033548203	1.553238571
Task condition	4.817282717	2	2.408641358	247.6306051	1.64414E-34	3.11379226
Error	0.758686617	78	0.009726751			
Total	6.195303867	119				

Table 5: ANOVA results for reaction times on the incongruent trials of both the modified Flanker tasks and the oddball task

Source of Variation	SS	df	MS	F	P-value	F crit
Participant	0.611754925	39	0.015686024	1.607099725	0.0381908	1.553238571
Task condition	4.81518855	2	2.407594275	246.6682549	1.87457E-34	3.11379226
Error	0.76131545	78	0.009760454			
Total	6.188258925	119				

The effect size (Cohen's d) for the difference between mean reaction times of forty participants on congruent and incongruent trials of the mixed modality flanker task was found to be 0.000. d was also found to be 0.000 for mean reaction times of forty participants on congruent and incongruent trials of single modality flanker tasks. However, a very small (Cohen, 1988) effect size of 0.068 was observed for mean reaction times on congruent trials of the mixed and single modality flanker tasks. The effect size was also found to be 0.067, again quite small, for mean reaction times of forty participants on the incongruent trials of the mixed and single modality flanker tasks. Thus, the differences in mean reaction times observed between similar trials on the mixed and single modality flanker tasks had small effect sizes. On the other hand, the effect sizes obtained for difference in mean reaction times between oddball task and congruent and incongruent trials of mixed modality flanker task were quite large ($d= 3.762$ and 3.729 , respectively). Also, the effect sizes were quite large between the mean reaction times of forty participants obtained for the oddball task and the congruent and incongruent trials of the single modality flanker task ($d= 3.622$ and 3.638 respectively).

This suggests a greater strength of differences in reaction times observed for the oddball task compared to the congruent or incongruent trials of the two modified flanker tasks.

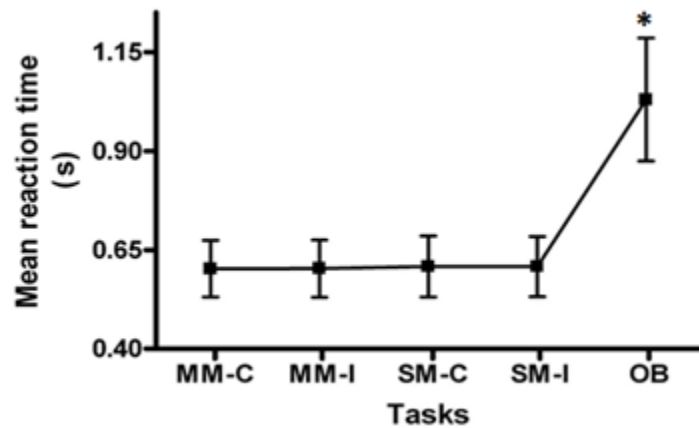

Figure 11. Mean reaction times (s) and standard deviation plotted for the congruent trials of mixed modality Flanker task (MM-C), incongruent trials of mixed modality Flanker task (MM-I), congruent trials of single modality Flanker task (SM-C), incongruent trials of single modality Flanker task (SM-I) and the target trials of oddball task (OB).

* denotes a significant difference ($p < 0.05$).

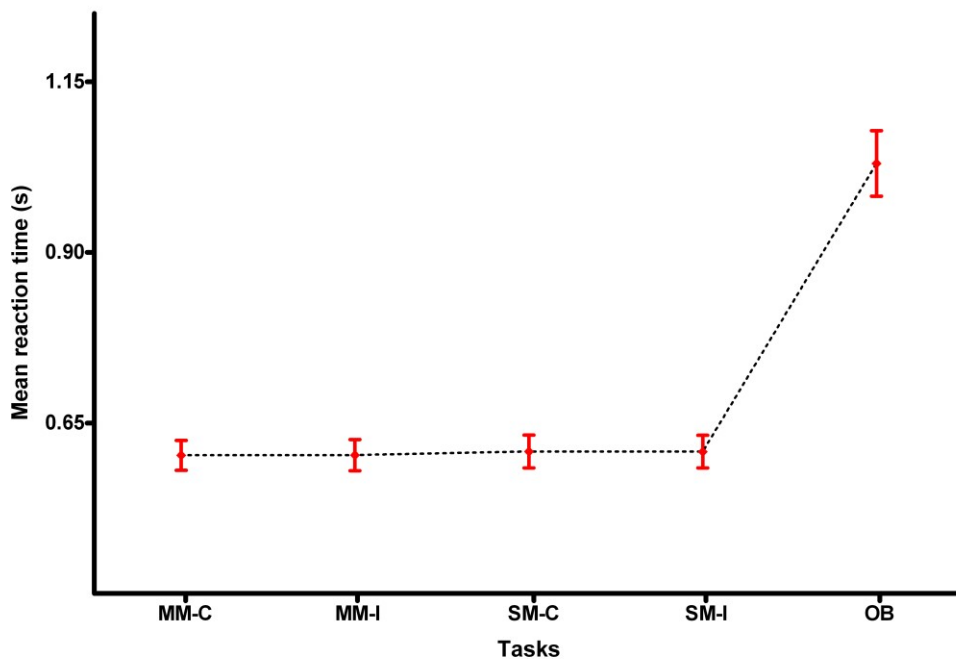

Figure 12. Mean reaction times(s) and 95% confidence intervals plotted for the congruent trials of mixed modality Flanker task (MM-C), incongruent trials of mixed modality Flanker task (MM-I), congruent trials of single modality Flanker task (SM-C), incongruent trials of single modality Flanker task (SM-I) and the target trials of oddball task (OB). The data suggests that 95% of reaction time values as observed for the forty participants lie between 0.581-0.625s for MM-C, between 0.580-0.626s for MM-I, between 0.584-0.632 for SM-C and SM-I and between 0.908-1.204 for OB.

Error was calculated for the congruent and incongruent trials of the modified Flanker tasks. Of the 2800 total responses on either congruent or incongruent trials (number of participants X Number of responses per participant per trial type) for the single modality Flanker task, there were 14 errors on congruent and 69 errors on

incongruent trials. Of the 2800 total responses on either congruent or incongruent trials (number of participants X number of responses per participant per trial type) for the mixed modality Flanker task, there were 5 errors on congruent and 32 errors on incongruent trials.

Table 6. Percent error* for target trials (mixed and single modality Flanker tasks)

	Congruent Trials		Incongruent Trials	
	Error	Error (%)	Error	Error (%)
Mixed modality Flanker task	5	0.18	32	1.14
Single modality Flanker task	14	0.5	69	2.46

*percent error calculated as error/total number of trials (2800)*100

5.2 ERP analysis for single modality Flanker task

The grand averaged waveforms for the single modality Flanker task were obtained using the EEG data for forty participants. The averaged waveform for congruent trials includes data from seventy trials per participant (2800 total). The averaged waveform for the incongruent trials includes data corresponding to seventy trials per participant (2800 total). The averaged waveform for distractor trials includes data

corresponding to twenty trials per participant (800 trials). The averaged waveform for standard trials includes data from forty trials per participant (1600).

The averaged waveform for congruent and incongruent trials showed a negative deflection with a peak at approximately 90 ms followed by a large positive peak around 170 ms and a bimodal positive deflection around 420 ms. These were identified as N100, P200 and the late positive complex respectively. The standard trials also showed similar peaks; however, these were slightly larger than those observed for the target trials. The distractor trials showed the N100, P200 and the late positive complex, all of which had the lowest amplitudes for the distractor trials. However, we additionally observed a large negative deflection peaking at approximately 300 ms. This negative deflection was identified as the N200. The N100, P200, and N200 for the distractor trials all showed larger amplitudes over more frontal areas, with decreased amplitude observed posteriorly (i.e., over parietal electrodes). Amplitude for the late positive complex, on the other hand, was largest over the parietal area and smallest over the frontal area. Figure 13 shows the averaged ERP data for forty participants on the congruent, incongruent, standard and distractor trials of the single modality Flanker task. Peak latencies and amplitudes for the congruent trials can be observed in Table 7A, for incongruent trials in Table 7B, and for the distractor trials in Table 7C.

Table 7A. Peak amplitudes and latencies of the ERPs for congruent trials of the single modality Flanker task

ERP	Latency (ms)			Amplitude (μ V)		
	Fz	Cz	Pz	Fz	Cz	Pz
N100	94	84	80	-2.7	-3.3	-3.2
P200	170	170	207	6.6	4.8	2.2
Late positive complex	417	384/417	384/416	3.4	7.9/7.9	9.7/9.5

Table 7B. Peak amplitudes and latencies of the ERPs for incongruent trials of the single modality Flanker task

ERP	Latency (ms)			Amplitude (μ V)		
	Fz	Cz	Pz	Fz	Cz	Pz
N100	102	79	79	-2.4	-3	-3
P200	166	166	162	6.1	4.6	1.6
Late positive complex	386	390/417	390/417	3.8	7.9/7.6	9.1/9.1

Table 7C. Peak amplitudes and latencies of the ERPs for the distractor trials of the single modality Flanker task

ERP	Latency (ms)			Amplitude (μ V)		
	Fz	Cz	Pz	Fz	Cz	Pz
N100	90	89	80	-2.5	-2.5	-2.3
P200	173	169	164	6.4	4.8	1.8
N200	308	280	269	-2.2	-0.3	-1.7
Late positive complex	418	418	418	3.6	8.4	10.1

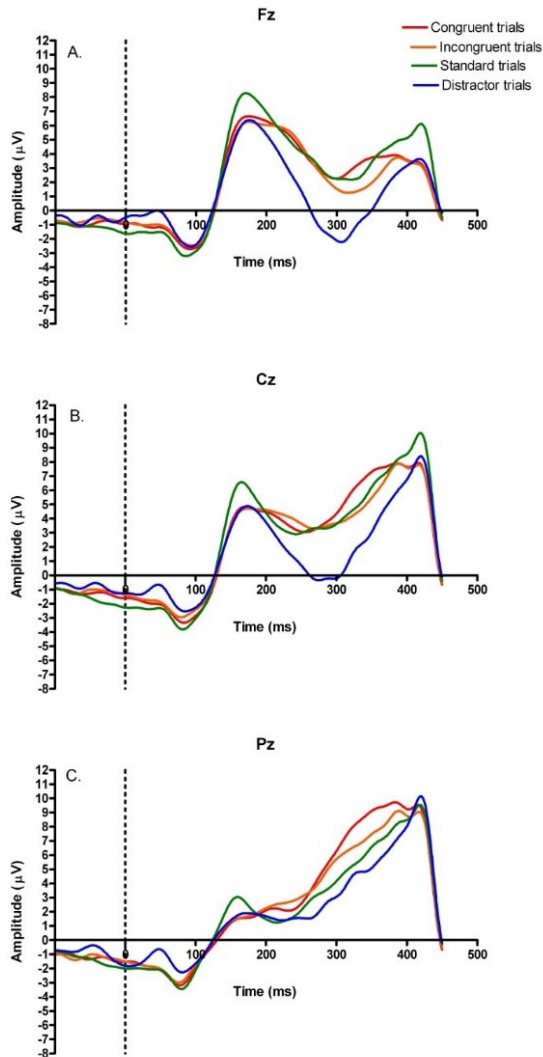

Figure 13: Grand averaged ERPs (N=40) obtained for the congruent (red, 2800 trials), incongruent (orange, 2800 trials), standard (green, 1600 trials) and distractor (blue, 800 trials) trials of single modality Flanker task on channels Fz, Pz and Cz. Note the negative deflection around 90 ms, followed by a positive peak around 170 ms, and a second positive deflection around 420 ms, identified as N100, P200 and late positive complex respectively. Note the frontal pattern for N100 and P200 and the parietal pattern for the late positive complex. An additional negative deflection (~300 ms), maximal over frontal electrodes, was observed for distractor trials. This was identified as the N200.

5.3 ERP analysis for mixed modality Flanker task

The grand averaged waveforms for the mixed modality Flanker task were obtained using the EEG data for forty participants. The averaged waveform for congruent trials includes data from seventy trials per participant (2800 total). The averaged waveform for the incongruent trials includes data corresponding to seventy trials per participant (2800 total). The averaged waveform for distractor trials includes data corresponding to twenty trials per participant (800 trials). The averaged waveform for standard trials includes data from forty trials per participant (1600).

The averaged waveform for congruent and incongruent trials showed a negative deflection with a peak at approximately 100 ms followed by a large positive peak around 180 ms and a positive deflection around 400 ms. These were identified as the N100, P200 and the late positive complex respectively. The standard trials also showed similar peaks, however these were slightly larger than those observed for the target trials. The distractor trials showed the N100, P200 and the late positive complex, all of which had the lowest amplitudes for the distractor trials. The N100 and P200 all showed larger amplitudes over more frontal areas, with decreased amplitude over parietal electrodes. The late positive complex, on the other hand, had maximal amplitude over the parietal area, which decreased over frontal electrodes. Figure 14 shows the averaged ERP data for forty participants on the congruent, incongruent, standard and distractor trials of the mixed

modality Flanker task. Peak latencies and amplitudes are reported in Table 8A for congruent trials, Table 8B for incongruent trials and Table 8C for distractor trials.

Table 8A. Peak amplitudes and latencies of the ERPs for congruent trials of the mixed modality Flanker task

ERP	Latency (ms)			Amplitude (μV)		
	Fz	Cz	Pz	Fz	Cz	Pz
N100	101	139	129	-2.8	-3.3	-3
P200	193	199	202	6.2	4.8	2.5
Late positive complex	358/414	384/415	383/416	4/3.4	8/8.1	9.3/8.9

Table 8B. Peak amplitudes and latencies of the ERPs for incongruent trials of the mixed modality Flanker task

ERP	Latency (ms)			Amplitude (μV)		
	Fz	Cz	Pz	Fz	Cz	Pz
N100	94	84	80	-2.8	-3.2	-2.9
P200	212	208	202	6.3	4.8	2.7
Late positive complex	414	386/417	385/417	3.9	7.0/7.6	8.1/8.5

Table 8C. Peak amplitudes and latencies of the ERPs for distractor trials of the mixed modality Flanker task

ERP	Latency (ms)			Amplitude (μV)		
	Fz	Cz	Pz	Fz	Cz	Pz
N100	94	89	180	-3.4	-3.2	-2.6
P200	164	153	154	7.6	6	2.8
N200	286	231	231	1	2.4	1.1
Late positive complex	416	417	416	5.3	8.6	8.6

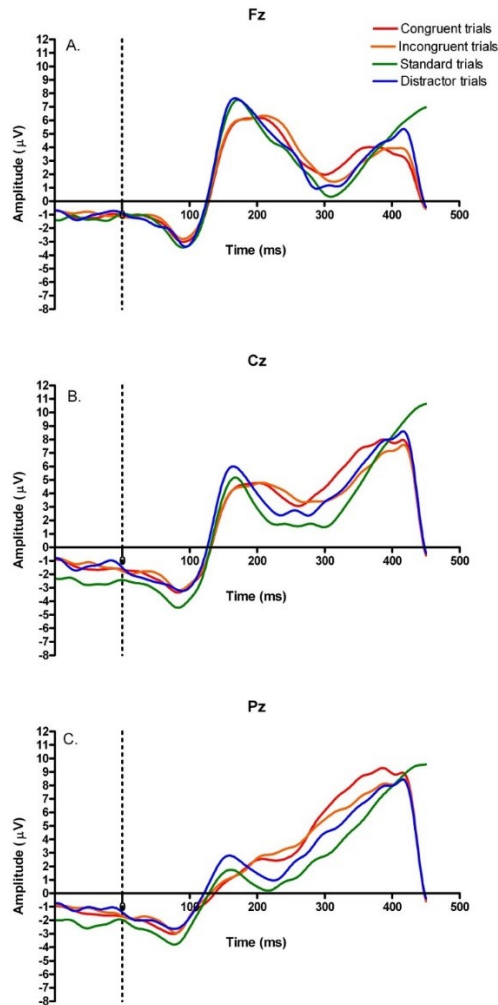

Figure 14: Grand averaged ERPs (N=40) obtained for the congruent (red, 2800 trials), incongruent (orange, 2800 trials), standard (green, 1600 trials) and distractor (blue, 800 trials) trials of mixed modality Flanker task on channels Fz, Pz and Cz. Note a large negative deflection around 100 ms, followed by a large positive peak around 180 ms, and a second positive deflection around 400 ms, identified as N100, P200 and late positive complex respectively. Note the frontal pattern for N100 and P200 and the parietal pattern for the late positive complex.

5.4 ERP analysis for oddball task

The grand averaged waveforms for the oddball task were obtained using the EEG data for thirty-nine participants. The averaged waveform for target trials includes data corresponding to 20 trials per participant (780 total). The averaged waveform for distractor trials includes data corresponding to twenty trials per participant (780 trials). The averaged waveform for standard trials includes data from 160 trials per participant (6240 total).

The averaged waveforms did not show any early potentials; however, a late negative potential around 400 ms was observed. This negative deflection was the largest for the target trials with maximal amplitude over fronto-central electrodes. We identified this waveform as the N350. Figure 15 shows the averaged ERP data for 39 participants on the target, standard and distractor trials of the oddball task. Peak latencies and peak amplitudes are reported in Table 9A for target trials, and Table 9B for distractor trials.

Table 9A. Peak amplitudes and latencies of the ERPs for the target trials of the oddball task

ERP	Latency (ms)			Amplitude (μ V)		
	Fz	Cz	Pz	Fz	Cz	Pz
N350	407	407	392	-4.1	-4.4	-4.1

Table 9B. Peak amplitudes and latencies of the ERPs for the distractor trials of the oddball task

ERP	Latency (ms)			Amplitude (μ V)		
	Fz	Cz	Pz	Fz	Cz	Pz
N100	385	385	389	-2.8	-3.6	-3

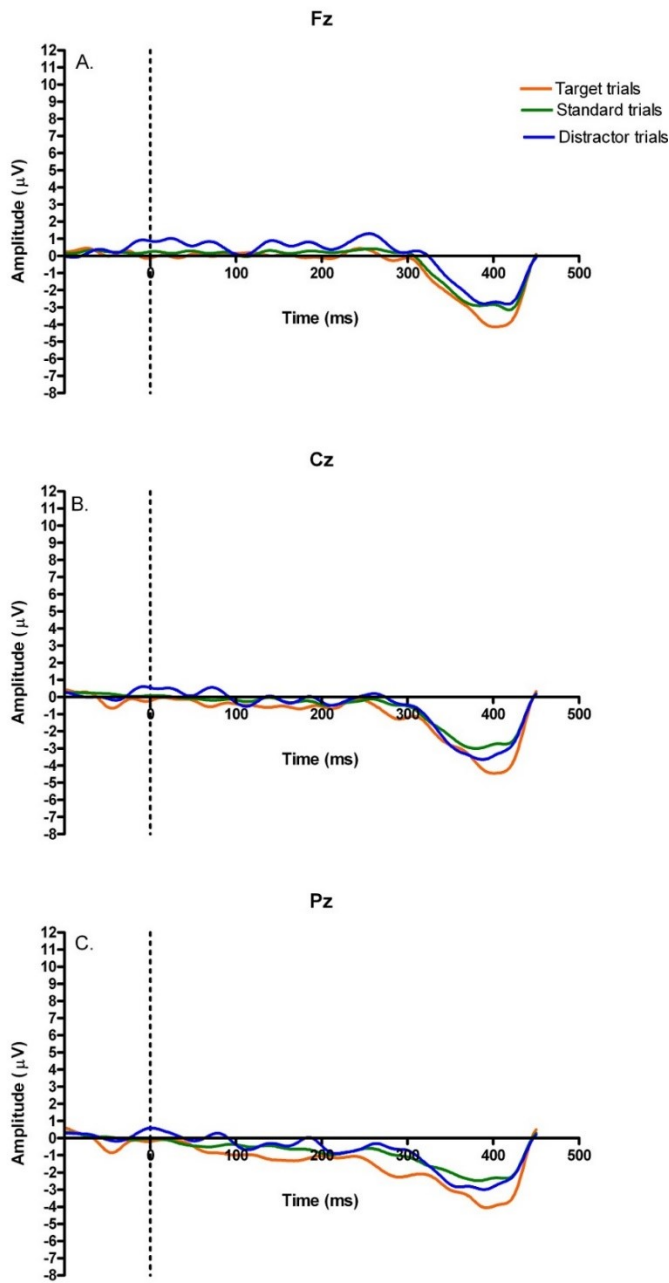

Figure 15: Grand averaged ERPs (N=39) obtained for the target (orange, 780 trials), standard (green, 6240 trials) and distractor (blue, 780 trials) trials of the Oddball task on channels Fz, Pz and Cz. Note a large negative deflection around 380 ms, identified as the N350.

5.5 ERP comparisons for target and distractor trials

A qualitative comparison of averaged waveforms obtained for target trials for the three tasks was done by overlaying the waveforms for the three tasks. The comparison was done for congruent and incongruent trials of the modified Flanker tasks and the target trials of the oddball task. We observed similar waveforms for the congruent and incongruent trials of the single and mixed modality Flanker tasks. A distinct N100, P200 and the late positive complex could be observed for the mixed Flanker tasks. The only ERP on the oddball task was the N350. The late positive complex showed a decrease in amplitude from parietal to frontal channels while the N100 and P200 were larger in more frontal channels. Figure 16 shows the averaged ERP data for forty participants (thirty-nine for oddball) on the target trials of the three tasks.

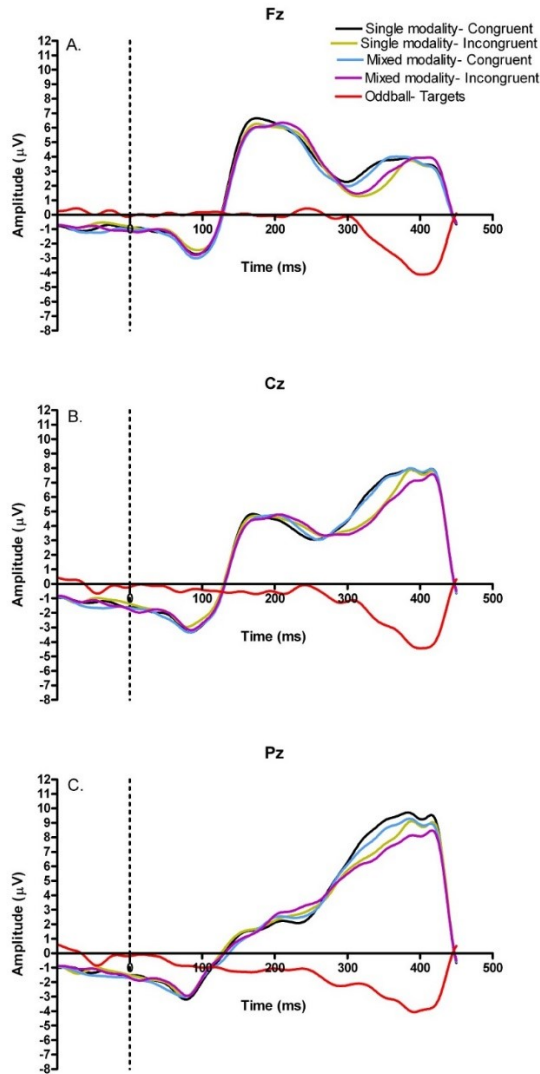

Figure 16: Grand averaged ERPs obtained for target stimuli on channels Fz (A), Cz (B) and Pz (C). The data were from the congruent (black line) and incongruent (green line) trials of single modality Flanker task (2800 trials each), congruent (blue) and incongruent (purple) trials of mixed modality Flanker task (800 trials each) and the target trials (red line) of oddball task (780 trials, blue line). The data reflect averaged ERPs for 40

participants for the single and mixed modality Flanker task and 39 participants for the oddball task.

A qualitative comparison of averaged waveforms obtained for distractor trials for the three tasks was done by overlaying the waveforms obtained from the three tasks. We observed similar waveforms for the distractor trials of the single and mixed modality Flanker tasks. A distinct N100, P200 and the late positive complex could be observed for the mixed Flanker tasks. Additionally, the N200 could be observed for the single modality and mixed modality Flanker tasks, with a larger amplitude N200 observed for the single modality task. The N200 showed a more frontal pattern in both versions of the Flanker task. As indicated above, the only ERP elicited by the oddball task was the N350. The late positive complex observed for the Flanker tasks showed a decrease in amplitude from parietal to frontal channels while the N100 and P200 were larger in more frontal channels. Figure 17 shows the averaged ERP data for forty participants (thirty-nine for oddball) on the target trials of the three tasks.

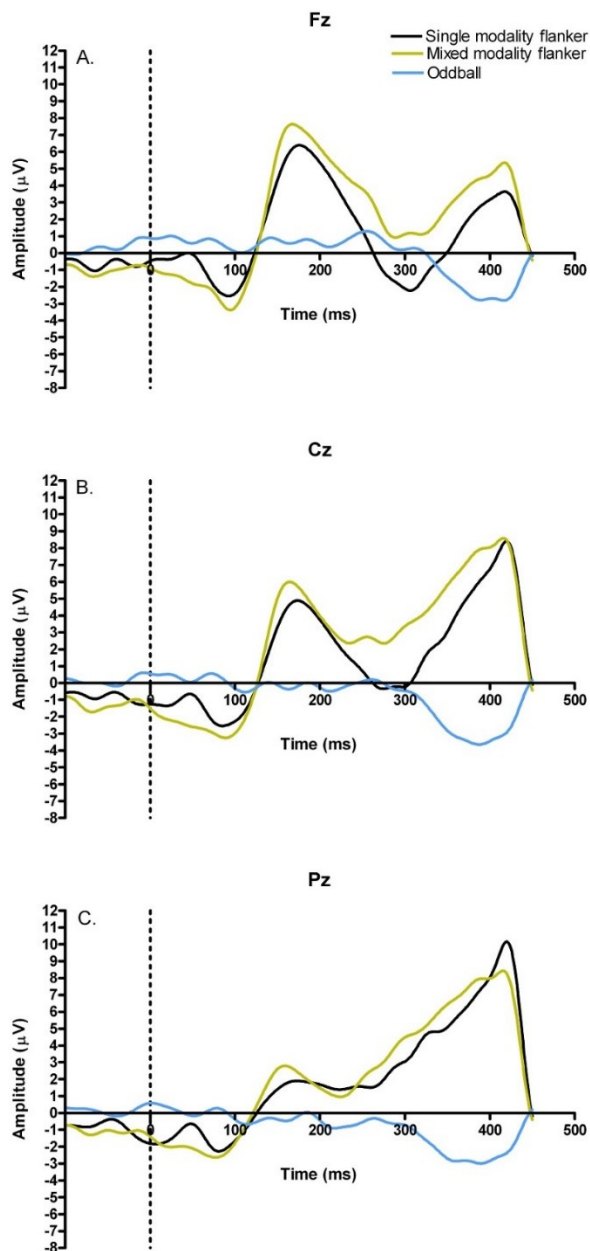

Figure 17: Grand averaged ERPs obtained for novel stimuli on channels Fz (A), Cz (B) and Cz (C). The data were from the distractor trials of single modality Flanker task (800 trials, black line), mixed modality Flanker task (800 trials, green line) and the oddball task (780 trials, blue line). The data reflect averaged ERPs for 40 participants for the single and mixed modality Flanker task and 39 participants for the oddball task.

CHAPTER 6: DISCUSSION

The primary objective of this study was to design and test modified versions of the Flanker task for obtaining ERPs for the assessment of attention. We aimed to compare the ERPs obtained from these modified Flanker tasks to the more traditionally used three-stimulus auditory oddball task. We expected to obtain behavioural measures related to attention (reaction time) and electrophysiological measures (the P300 and its sub-components, the P3a and P3b). In brief, we had hypothesized that the modified Flanker tasks would elicit the P3a and P3b, and that these potentials would be more distinct than those elicited via the three stimulus oddball.

Interestingly, we did not observe the P300 and its sub-components the P3a and P3b for any of the three tasks studied. Alternatively, the modified Flanker tasks provided other robust measures of studying inhibition of attention. The following sections provide more details about our main findings, interpretation of the results, and limitations of the study with future directions.

6.1 Main Findings

The key findings from the analyses of the EEG data were as follows:

1. Both modifications of the Flanker task were useful in obtaining electrophysiological data relevant for the assessment of attention in young, non-

disabled individuals through identification of early ERP components N100 and P200.

2. The modified Flanker tasks were able to indicate novel attentional processing different from the target trial analysis by means of the N200 but not the P3a or P3b analysis.
3. The distractor trials of modified Flanker tasks did not provide a more distinct P3a and P3b. Rather the P300 was perhaps superimposed by a larger P400, which is known to be associated with familiarity to a stimulus. For the target trials, this late positive ERP component was probably the positive ERPs associated with single or choice reaction tasks (described below).
4. A correlation between reaction times and P300 component latencies could not be established since neither P3a nor P3b was observed for any of the tasks.
5. The mixed Flanker tasks provided a better means of quantifying attention compared to the oddball task by means of providing larger and distinct ERPs. However, this was deduced only through the qualitative analysis of early ERP components.
6. The oddball task, despite being designed on lines of Comerchero and Polich (1998, 1999), did not yield any ERPs except the N350. Assessment of attention, which is quite widely done using the oddball paradigm, could not be established in our experiment.

6.2 The modified Flanker tasks

6.2.1 The late positive complex

In Flanker tasks it has normally been shown that analysis of target trials (frequently presented) results in a large late positive complex on the EEG, known as the P300. The P300 is often associated with attention process as outlined in a previous section. As discussed, the P300 is not a unitary waveform but rather it has two components. The component of the P300 associated with stimulus evaluation is called the P3a. The P3a typically has a peak latency between 250-300 ms. The second component of the P300 that is associated with response to a stimulus is known as the P3b. The P3b typically has a peak latency between 300-350 ms after stimulus onset. We hypothesized that similar to this notion, our modified Flanker tasks would reveal a large P3b on target trials and a P3a waveform on the novel or distractor trials. However, as outlined in the results section we obtained a single large positive component that peaked around 450 ms for the distractor trials. As for the target trials, we obtained a large positive complex with an earlier and a later peak in the 375-425 ms time range (see Figures 13 and 14). Both of these positive complexes showed a similar topographic representation with greater amplitudes over parietal electrodes relative to those over fronto-central regions.

Considering past research related to the P300 and its sub-components P3a and P3b, we do not believe that the components noted above are the P3a or P3b waveforms. The late positive components we obtained from our study resemble other late positive

components of the ERP reported in previous work, including the P400 and P-SR and P-CR components as described further.

6.2.1a Late positive complex obtained for distractor trials:

The P400 is known to be associated with processing of familiar and unambiguous stimuli, which was demonstrated in an experiment conducted by Carver, L. et al (2006) where the investigators studied the brain potentials in infants associated with presentation of a familiar or an unfamiliar object. Sixty-one 18-month old infants were included in this study. They were presented with either one of two matched toys at a time, one of which was their favourite toy that was brought in by the parents. The toys were presented to the infants as 3-dimensional (3D) objects in a display box (Figure 18) or the infants were provided 2-dimensional (2D) images of the toys. EEG was recorded and ERP analysis performed on trials when the stimulus presentation involved the unfamiliar 3D or 2D object or the familiar 3D or 2D object. The results showed a large P400 waveform, with greater amplitude observed on parietal compared to fronto-central electrode sites. The P400 waveform was larger in amplitude for familiar than for unfamiliar objects. Since the familiarity with the nature of the object was greater when presented as a 3D object than as a 2D image, the P400 was larger in amplitude for the 3D object trials than for the 2D trials. This experiment showed that the P400 is related to the level of familiarity with the stimulus.

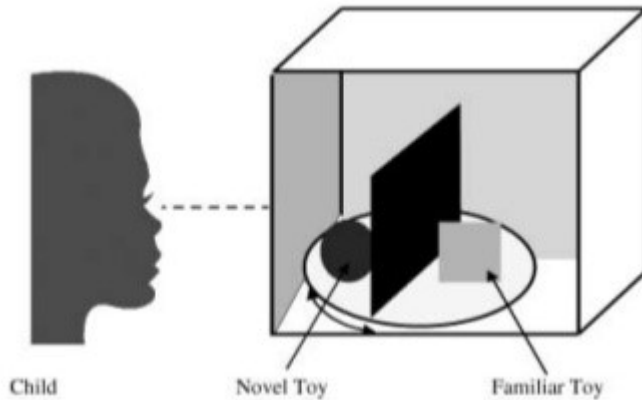

Figure 18: Experimental setup for presenting the novel and familiar toys in a 3D display box. Obtained from Carver, L et al (2006)

Another study conducted quite recently (Kornmeier, J. and Bach, M., 2014) presented young healthy adults with images of the Necker cube and Boring's Old/Young woman's face. These images are basically ambiguous images where the same image can be perceived as either two differently facing cubes or as an old or a young woman. The investigators used these stimuli mixed with unambiguous variants of a cube or a woman's face to study ERPs associated with ambiguity. The investigators noticed upon ERP analysis that for presentation of an unambiguous stimulus, a large, late positive ERP, the P400, was observed. The amplitude of the P400 reduced for ambiguous stimuli, indicative of the role of this waveform in depicting perception of an individual.

In light of this evidence, we believe that the presence of the late positive complex in our single modality modified Flanker task was the result of using familiar images for our distractor stimuli (e.g., chick, bear, acorn etc.). The inclusion of these familiar images must have initiated a processing of the familiarity with the image more so than the

processing of them as novel stimuli, hence resulting in perhaps the P400 ERP.

Examination of the P400 waveform does reveal a small positive peak on its upward slope that may be the P3a (see Figure 17). It may be possible that the P3a that was produced as a result of the novelty was superimposed by this late positive complex owing to the greater processing related to familiarity as opposed to novelty.

We observed a similar (possibly P400) late positive complex in the mixed modality Flanker task. The distractor trials in this task involved sound clips that were recognizable by the participant. Examples of these sound clips included laughter, sneezing, a crash and a dog barking. All of these sounds were likely more familiar to our participants than the standard or target stimuli on the Flanker tasks. Thus, we conclude that the familiar nature of distractor trials initiated different sensory processing than what we had hypothesized; hence our modified Flanker designs did not seem to generate a P3a waveform in response to novelty.

6.2.1 b Late positive complex obtained for target trials:

Much like the distractor trials, the modifications to our Flanker tasks produced a late positive waveform for the target trials as well. The difference from the distractor trials was that the waveform obtained for the target trials had a bimodal representation (i.e., it had two peaks). Since both of these positive complexes for distractor and target trials seemed to appear around the same time point, we may expect the positive waveform for the target trials to also possibly represent the P400. However, the stimuli

presented for target trials (arrows) were unfamiliar for the participants. All of the participants involved in the current study had never performed the Flanker task before and did not know about the task until the day of the experiment. Unfamiliar stimuli may well produce a P400, but one would anticipate its amplitude would be less than that produced for familiar stimuli (as discussed earlier). Thus, we believe that a different mechanism underlies the ERPs obtained during target trials.

Earlier studies have shown that the Flanker task, which resembles a go/no-go paradigm, can be used to study the choice reaction time in individuals (Jones, S.H. et al, 1991, Eriksen and Eriksen, 1974, Sanders, A.F., Lamers, J.M., 2002). This basically means that since multiple stimuli are involved within the Flanker task, the individual has to assess a decision on multiple levels and choose the appropriate response. This aspect of the Flanker task has been shown to exhibit another unique property of the P300 ERP that was explained in a series of experiments conducted by Falkenstein et al (1991, 1994a, 1994b, 1995). Earlier, many experiments with a go/no-go pattern were conducted that resulted in a large P300 with a single peak that had greater amplitude over parietal regions for the go trials and a more central pattern for the no-go trials (Karlin et al. 1970; Hillyard et al. 1976; Simson et al. 1977). This topographic shift for the no-go trials was explained to be due to an inhibition mechanism (Karlin et al. 1970) or due to the absence of a motor inhibitory potential (Kok et al, 1986). However, similar observations were also made for count/no-count paradigms suggesting that the motor inhibition is not a process involved in generation of a P300 (Pfefferbaum, et al 1985). Thus, the P300 can result from different processes or generators. Hohnsbein et al (1991)

and Falkenstein, et al (1993, 1994a, 1994b) showed that two components of the P300 exist - the P-SR, associated with simple reaction times and the P-CR, associated with choice reaction times. The P-SR is an early component of the P300 while the P-CR is a late component. Go/no-go paradigms can produce these two subcomponents separately. The P-SR, much like the P3a, indicates an early stimulus evaluation process, while the P-CR reflects the later choice evaluation and response process. In one of the experiments (Falkenstein et al, 1994a), the investigators had their participants perform a 2-choice and a 4-choice go/no-go task. The ERP analysis revealed that the participants exhibited a large positive complex with two peaks, one at 390 and another at 540 ms (Figure 19). With a greater number of choices, the temporal separation between the two peaks grew larger. The Flanker designs used in the present work were also a go/no-go paradigm with 2 choices, and hence the target trial ERP's presented much like the ERP's obtained for the Falkenstein experiment. Thus, in line with this, we believe that our Flanker tasks might have resulted in a P300 with P-SR and P-CR peaks. Since the target and standard trials in our Flanker designs were the same we did not expect much difference in their ERPs and we observed the same. Also, the Flanker task is considered to be a response competition paradigm (Eriksen, C. 1995), which can initiate multiple cognitive processes and hence might present differently from other paradigms like the oddball task.

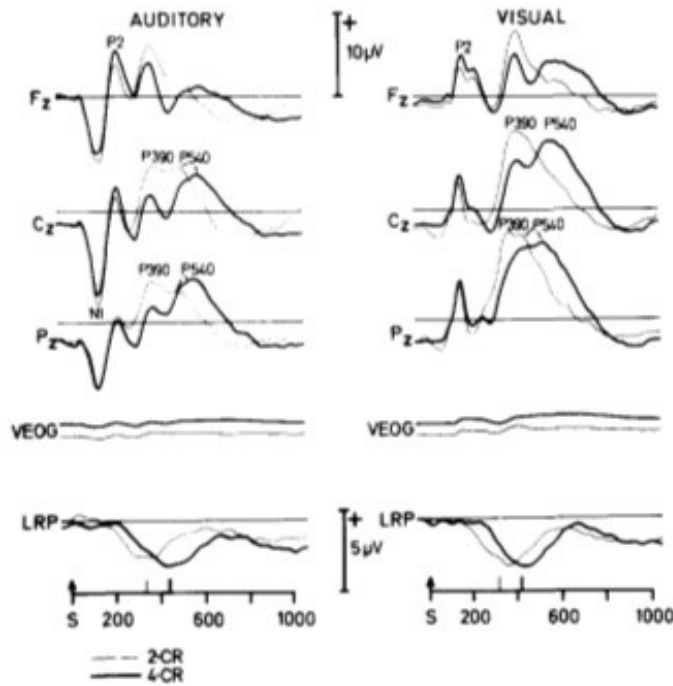

Figure 19: ERPs obtained on two choice (2CR) and four choice (4CR) reaction tasks. Note the increasing differentiation between P-SR (P390) and P-CR (P540) with increase in choices. Also note the more parietal pattern (third ERP waveform from top, in both right and left panes) since the amplitudes for P-SR and P-CR are larger on Pz channel than the Cz or Fz for both the auditory and visual modality stimulus. Obtained from Falkenstein, et al (1994a).

Although, we believe that the late positive complexes possibly depict the aforementioned ERPs, there seems to be a potential for signal processing error and the time lag in presentation of the auditory stimuli. These have been further discussed as limitations of the study in following sections.

6.2.2 The N200 effect and detection of novelty

The N200 or N2 effect is a fronto-central negativity with a latency of approximately 300ms. The N200 is found more on no-go than the go trials. We observed a negative deflection between 200-300 ms (see Figures 13 and 14) for our data on both the distractor and target trials for the mixed and single modality Flanker tasks. However, the N200 was most observable for the distractor trials of the single modality Flanker task. The N200 was larger fronto-centrally and had greater negativity for the distractor trials (no-go) than for the target trials (go). Additionally, the N200 for auditory distractors was smaller in amplitude compared to the N200 for visual distractors.

These results are in line with literature suggesting that the N200 effect is indicative of an inhibition process (Eimer, 1993). This theory is postulated on the basis of the fact that a larger N200 is observed for no-go trials than for the go trials. However, another experiment conducted by Donkers and Boxtel (2004) showed that the N200 is more associated with a conflict evaluation process than with an inhibition process. The same was observed for the Falkenstein study explained previously, where they did not obtain a similar N200 effect on auditory no-go trials which tended to have lesser need for an inhibition process due to lower number of false alarms compared to the visual condition. Similar arguments against the inhibition theory have been suggested by others as well (Karlin et al., 1970, Hillyard, et al, 1976). However, since we did obtain an N200 effect for the mixed modality Flanker task but it was lower in amplitude to the N200 effect observed for the single modality Flanker task, our results argue against the conflict

monitoring theory. We expect a greater conflict processing with our mixed modality Flanker task than with the single modality Flanker task due to greater discrimination between the stimuli types and hence a greater N200 effect for the former is expected. Also, if it is argued that the N200 effect should be associated with the target trials, we should not have noticed any differences in N200 effects for both the tasks since the target trials are essentially the same. Thus, our results support the inhibition theory of the N200 effect, which is true for both the modified Flanker tasks.

Besides the role of N200 in describing inhibition processes, it has also been known to be associated with novelty. The first study to report novelty with visual stimuli was done by Courchesne et al. (1975). They used stimuli that included 80% standard stimuli (the number “2”), 10% target stimuli (the number “4”), and 10% distractors or novel stimuli. The participants had to count each time the targets appeared. The participants were divided into two groups; one group received complex novel stimuli (random coloured patterns) and the second group received simple stimuli (black and white interpretable images). The results of this experiment showed that the novel stimuli elicited a large frontal N200 compared to the frequent standards or the rare targets. Also, the simple novel stimuli were much less effective in eliciting the frontal N200 compared to the complex stimuli. Additionally, the results showed that the response habituated if the stimuli were frequently repeated. Similar results were shown for the auditory stimuli in a study conducted by Strobel, A. et al (2008). The investigators for this study used auditory stimuli to study the novelty effect and observed that the N200 was larger in amplitude for novel stimuli than the non-novel rare targets.

In our modified Flanker tasks the distractor stimuli represented the novelty. Thus, an analysis of the distractor stimuli should also produce the N200 component associated with the detection of novelty. We found that the distractors elicited a large frontal N200 that decreased over parietal areas and was larger for these novel stimuli compared to the targets. However, the same was not seen for the oddball tasks. Thus, our tasks were successful in eliciting a waveform associated with novelty detection, if not via the P3a but rather via the N200 ERP. We also noted that the N200 was larger for the single modality Flanker task compared to the mixed modality Flanker task. We had expected that the mixed Flanker task would exhibit greater novelty and more discrimination of the distractors from the targets within the task. However, our results show that the visual stimuli elicited a more novel response compared to the auditory distractors used in the mixed modality Flanker task. This result is also in agreement with findings of Ümmühan İšoğlu-Alkaç et al (2007) who showed that in their mixed modality oddball paradigm (visual and auditory stimuli) the N200 was smaller in amplitude compared to the single modality oddball paradigm (auditory stimuli only). A possible explanation for our results is that our visual stimuli acted as complex stimuli (as in Courchesne's experiment) due to the small size of the images. Often the participants complained that their vision would get blurry during the experiment, which might have made it difficult for them to recognize the images coherently. But the auditory tones were clearly recognizable and must have acted as simple stimuli. This possibly resulted in a larger N200 for the single modality Flanker task with visual distractors than for the mixed modality Flanker task with the auditory distractors. The recognisability is also evident from the late positive complex in

the two tasks, which was larger for the auditory stimuli than for the visual distractor stimuli (as explained in the previous section).

6.2.3 N100 and P200

The N100 or N1 is a negative ERP with a peak latency occurring in the 80-120ms range with a more fronto-central pattern (Mangun, G.R. and Hillyard, S.A., 1991). The N100 is considered to be reflective of a pre-attentive process since its amplitude depends largely on the onset of the stimulus (Spreng, M., 1980). The N100 is also linked to an individual's selective attention process (Hillyard, S.A., et al, 1973, Luck, S.J. et al, 2000).

To study the effect of a go/no-go and a Flanker paradigm on N100 in individuals with attention deficit hyperactivity disorder (ADHD) and healthy controls, Johnstone, S. et al (2009) conducted an experiment where forty children between the ages of 8-14 years were allocated to one of two groups - ADHD or control. Both the groups performed the two tasks while their ERPs were recorded. The results showed that the ADHD group exhibited smaller N100 compared to the control group, suggesting the role of N100 in attentional processes.

Topographically, the amplitudes of the N100 were larger fronto-centrally than other areas. Additionally the N100 on no-go trials was larger than the N100 on go trials. These findings suggest that the N100 is reflective of an individual's attentional processes and the capacity of the same. In line with this evidence, the N100 was observed in the

current results for both of the modified Flanker tasks (but not for the oddball paradigm), with the N100 showing a fronto-central pattern (i.e., a greater amplitude N100 was observed over fronto-central electrodes). Our results also showed that the distractor stimuli in the mixed modality Flanker task exhibited slightly larger amplitude N100 compared to the target trials but the amplitudes were similar for the distractor and target stimuli on the single modality Flanker task. This is possibly due to greater pre-attentive processing of the sound clips compared to the visual stimuli. Similarly, Ümmühan Işoğlu-Alkaç et al (2007) also showed that their mixed modality oddball paradigm showed greater N100 amplitude compared to the single modality auditory oddball paradigm.

Besides the N100, researchers have often studied the P200 for assessing attentional processes. The P200, or P2, is an early positive ERP peaking within the range of 150-275 ms. In the experiment conducted by Johnstone, S et al (2009) described above, it was also demonstrated that P200 amplitude was greater for the control group compared to the ADHD group. This finding suggests the P200 may also be indicative of selective attention processes (Figure 20). In our experiment as well we obtained a large P200 for our modified Flanker tasks (but not on the oddball paradigm), which had greater amplitude on fronto-central electrodes. Unlike the N100, which was not distinguishable on the parietal electrodes, we were able to observe a small P200 on parietal electrode sites as well.

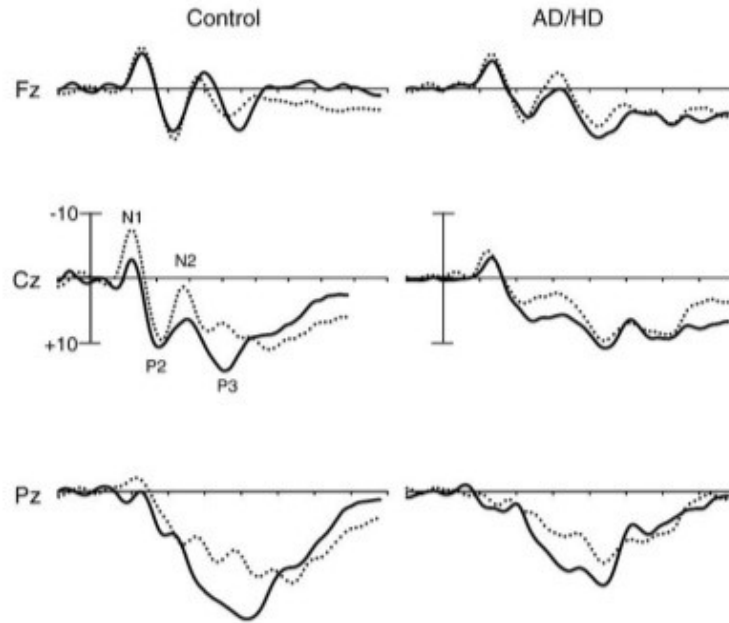

Figure 20: ERPs obtained on the go (solid line) /no-go (dotted line) task in the Johnstone, S. et al (2009) experiment. Note greater N100 and P200 amplitude for the control group (left pane) compared to the ADHD group (right pane).

Brown, C.R. et al (2006) conducted an experiment to study intermodal effects on the P200. Their participants performed a multimodality two stimulus oddball task (visual and auditory) and a single modality two stimulus oddball task (auditory). Their results showed that the P200 amplitude was larger for the multimodality oddball task compared to the single modality oddball task. Thus we can postulate that since the N200 was largest for our single modality Flanker task, attenuation of the P200 was greater for the single modality Flanker task compared to the mixed modality Flanker task.

We observed similar results to those outlined above where the mixed modality Flanker task showed a larger P200 for the distractor stimuli compared to the single

modality task. This increase in amplitude in the mixed modality task can be attributed to attenuation in the N200 following the P200. The N200 for the mixed modality Flanker task was found to be smaller than the single modality Flanker task, as noted earlier, and hence lesser attenuation of the P200 corresponds to the mixed modality Flanker task. Since the target trials were similar between both modifications, we obtained similar amplitudes for P200 for the target trial analysis of the mixed and the single modality Flanker tasks.

On the standard trials in our mixed Flanker tasks, we noticed a larger N100 and P200 component with greater amplitude over frontal relative to parietal electrodes when compared to the target trials. This result replicates the results from a study conducted on children with ADHD and healthy controls, conducted by Smith, J. et al (2004). The children were asked to perform a go/no-go task with warning trials to cue the nature of the next trial. The investigators noticed a slightly larger amplitude N100 and P200 on no-go versus go trials but a significantly smaller amplitude of both these waveforms for children with ADHD compared to the age-matched healthy controls (Figure 21). A larger N100 and P200 on no-go trials might suggest a role in pre-attentive processing through inhibition. Also, since the amplitudes of N100 and P200 were smaller in children with ADHD, it suggests a role of these components in driving behavioural inhibition. Also, since the latencies of these ERPs were longer for children with ADHD, it further explains that these children took longer to inhibit responses on the no-go trials compared to healthy controls.

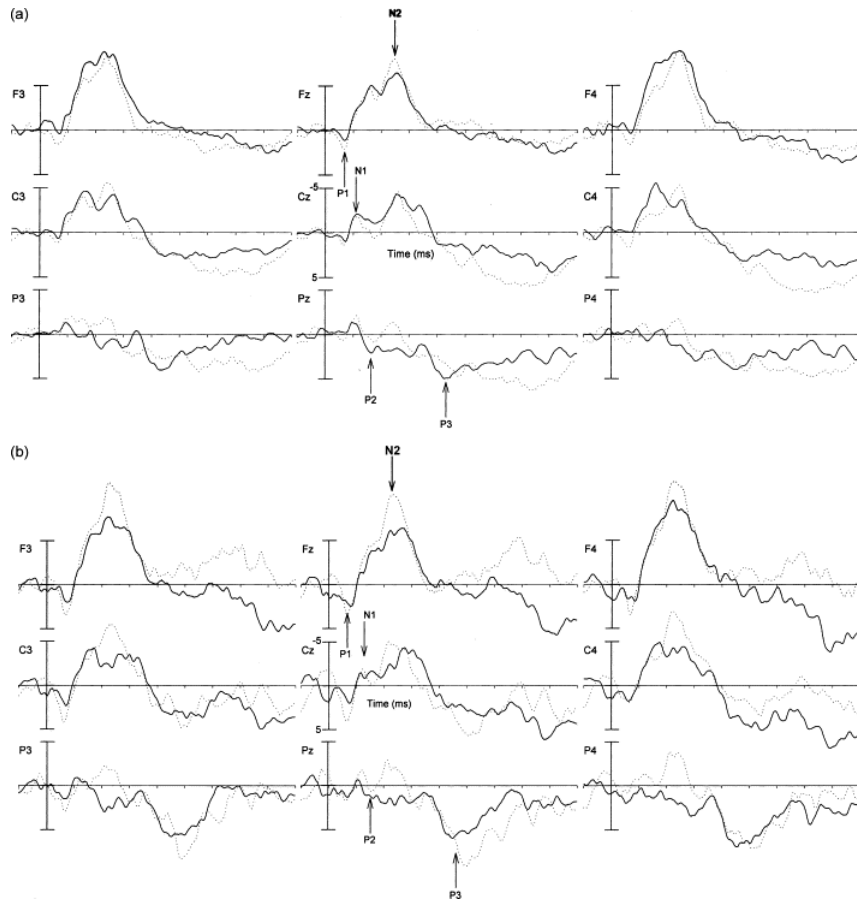

Figure 21: ERPs for a. Go trials and b. No-Go trials for children with ADHD (solid line) and their healthy counterparts (dotted line) in the experiment conducted by Smith, J. et al (2004).

Thus, we believe that a mechanism of inhibition of attention may explain the role of N100 and P200 in pre-attentive processing.

6.3 The oddball task

6.3.1 The N350

Our results showed that the oddball task did not generate any electrophysiological indicators of attention. This finding was true for analysis of both distractor and target trials. Instead of a P300 waveform (or its sub-components P3a and P3b) we obtained a negative deflection on the EEG recording. This negative deflection, which we believe represents the N350, had an onset latency in the 350-450 ms time range.

The N350 is an ERP that has often been associated with the phonotactic knowledge and lexical-semantic processing of the stimulus and the semantic matching of pictures (Friedrich, M. and Friedrici, A., 2005; Barrett, S., Rugg, M., 1990). Additionally, electrophysiological testing of psychopaths revealed a connection of the N350 with affective processing as well (Kiehl, K. et al, 1999, K. et al 2006). However, since the stimuli in the oddball task were all pure tones and non-linguistic in nature, we do not expect a semantic process to be involved in stimulus evaluation. However, an increase in the negativity of this ERP has also been shown to be associated with reduced arousal (Ogilvie, R. et al, 2001), drowsiness, sleep onset and stage II of sleep (Pratt, H. et al, 1999, Cote, K., 1999, Ibáñez, A. et al 2006).

A change in the state of arousal can significantly affect our cognition. Polich and Kok (1995) described in a review how arousal significantly effects information processing in an individual. They noted that besides the task related changes that can

affect an individual's cognitive performance, state-related changes of an individual's bodily functions can also impact the cognitive performance. Psychophysiological differences in the tonic and phasic changes in arousal can affect the cognition. Tonic changes in arousal are manifestations of slower fluctuations in the general or non-specific background arousal state of an individual (as measured via ECG, EEG etc.) while phasic changes are stimulus dependent energetic reactions (orientation response, skin impedance etc.). These changes can significantly affect information processing in individuals. This phenomenon was also observed in an experiment conducted by Harsh, J. et al (1994) who examined the electrophysiological and behavioural changes associated during a wake/sleep transition. The investigators included 16 young (18-35 years) males and females who did not have any sleep disorders or other neurological problems. The participants performed a two-stimulus oddball task where they had to respond to the rarely presented 1500 Hz pure tone (attend condition) while ignoring the frequently presented 1000 Hz pure tone (ignore condition). They performed this experiment in full wakefulness while they transitioned into drowsiness and then to sleep. An analysis of their electrophysiological (measured using EEG) and behavioural outcome measures (reaction time analysis) revealed that in full wakefulness the participants exhibited faster reaction times (<500 ms) or intermediate reaction times (500-750 ms) which corresponded with a positive deflection on the EEG at approximately 300 ms (i.e., the P300). However, as the subjects transitioned into sleep from Stage IA to IB to IIA and IIB, a significant reduction in the amplitude of the P300 was seen. This reduction in amplitude also corresponded with slower reaction times (>750ms). Additionally, as the P300 amplitude was reduced to baseline, a negative deflection, the N350, started to

appear. This waveform was related to the slower reaction times and it showed a larger amplitude fronto-centrally. The N350 appeared on the EEG in stage IA sleep over these areas. The N350 was apparent on parietal electrodes during stage IB sleep albeit at a lower amplitude than on fronto-central electrodes. These results, obtained from analysis of the attend condition, are shown in Figure 22.

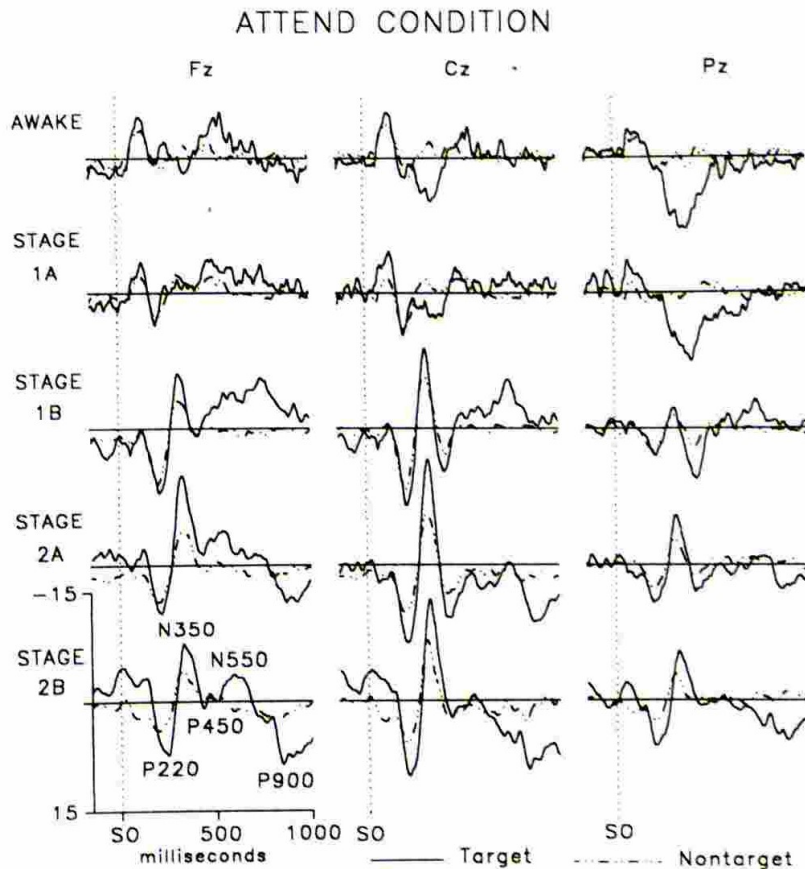

Figure 22: ERPs obtained during task performance in attend condition as participants went from awakened status towards falling asleep. Note the increase in N350 amplitude (upward deflection with a peak around 350-400ms) in channels Fz, Pz and Cz (from left to right) with sleep stage progression (from top to bottom). Obtained from Harsh, J et al, 1999.

Similar observations were made for the EEG data associated with the ignore condition. The N350 could be seen as the participants transitioned from wakefulness to sleep. The amplitudes of the N350 were higher fronto-centrally than on electrodes overlying the parietal region. It was also observed that the N350 obtained for the rare stimuli or the target was larger than the N350 obtained for the frequent stimuli or the standards.

Another study by Nielsen-Bohlman et al (1991) also reported a later onset, negative polarity ERP (N340, resembling the N350 in other experiments) that was associated with rare or infrequent stimuli than with the frequent stimuli. The participants in this study did not have to respond to any of the stimuli. The stimuli included frequent tones (80%), infrequent tones (10%) and novel tones (10%). The investigators observed an augmentation in the negativity of this waveform with transition to sleep for all stimuli conditions. This augmentation in the amplitude of the waveform was largest for the infrequent tones. This result also suggested that selective processing of auditory stimuli persists in sleep. This is a possible reason why individuals, despite being drowsy, were capable of responding to the stimuli and hence, showed longer reaction times on the oddball task.

Our results from the oddball task were consistent with those reported in the aforementioned studies. Reaction times for the oddball task were considerably longer than anticipated, being significantly different from reaction times observed for the Flanker tasks as well as different from values established in the literature, usually 350-

450 ms (Iragui, V. et al, 1993, Houlihan, M et al, 1998). Additionally, analysis of the electrophysiological data showed an N350, which is likely indicative of the fact that participants were drowsy during performance of the oddball task. The presence of the N350 could have resulted in diminution of the P300 components. Alternatively, a P300 component was not present as participants were not sufficiently attending to the stimuli. Also, the N350 associated with the infrequent (10%) target trials was larger in amplitude compared to the novel stimuli (10% occurrence). The N350 obtained from our data is seemingly larger in amplitude on the fronto-central electrodes than on the parietal sites.

It could be argued that the drowsiness observed among the participants was in some way associated with the order in which the participants performed the oddball task (i.e., first, second or last among the three tasks). However, owing to the randomization procedure, there were as many participants who performed the oddball first, as performed it second or third in the order of three tasks. Examination of the individual participant data epoched for the oddball task revealed the presence of the N350 irrespective of the order in which they performed the oddball task.

In light of the delayed reaction times and presence of the N350, we can conclude that the oddball task was perhaps monotonous and not effectively engaging resulting in reduced attention and greater event-related potentials associated with a lack of arousal.

In addition to the behavioural and electrophysiological evidence, a number of participants mentioned at the end of the experiment that the oddball task was monotonous

task and that they were feeling sleepy by the end of it. Thus, we believe that the attentional processes were reduced in our participants due to the monotonous nature of the task and the P300 complex (and its components) were lost due to interference with the N350.

Further still, like the modified Flanker tasks, there is a potential of signal processing error and presentation of the auditory stimuli associated with the oddball task. These have been discussed in details further as the limitations of the study.

6.4 Reaction time analysis

The analysis of the reaction times for all three tasks revealed significant effects of participant and task condition. This means that reaction times were significantly different among the participants as well as within individual participants on the three tasks.

When comparing reaction times on correctly answered congruent and incongruent trials within the same modality Flanker task, we did not notice a significant difference. The same was observed for the mixed modality Flanker task. However, the reaction times for oddball targets were significantly longer compared to the mixed Flanker tasks (congruent or incongruent trials). Normally, we expect longer reaction times on incongruent trials compared to congruent trials since greater attentive processing is required to answer for incongruent trials (Hommel, B., 1997, Head, A.S., Pedoe, DS, 1990). However, the nature of instruction can affect this relationship. This was shown by

a study conducted by Uemura, K. et al (2013) in which participants were divided in three groups based on how they were instructed to perform a Flanker task. One group was told to answer as accurately as possible. Another group was asked to respond as fast as possible. The third group was a control group that was given no specific instructions. It was observed that participants had longer reaction times to the incongruent trials in accuracy instruction group but this was not true for the speed instruction group. In our study the participants were instructed to ‘answer as fast and as accurately as possible’, which could possibly have resulted in the reaction times we obtained.

The participants in our study took considerably longer to respond on the oddball task (1.030 s) compared to what previous studies reported (between 350-450 ms) (Iragui, V. et al, 1993, Houlihan, M et al, 1998). These longer reaction times are likely explained by the less engaging nature of the oddball task wherein participants were not very attentive while responding to this task. The longer reaction times on the oddball task are in line with the fact that we observed the N350 (associated with drowsiness as explained earlier) as a late ERP component in the oddball target trial data.

6.5 Limitations and future directions

There are several limitations associated with this research that need to be considered when interpreting the results. The first is the lack of ERP data from the oddball task. For the purpose of this research, we had designed the oddball task in line with the task design that was implemented by Comerchero and Polich (1998,1999). That

design for the oddball task has been used very commonly for attention based studies and researchers have successfully employed it to obtain the P300 and its sub-components, the P3a and P3b. However, despite maintaining the same protocol and design for the oddball task, we were not able to elicit ERPs that were relevant for the analysis of attention. We have suggested that this finding (or lack thereof) could be explained by the lack of engagement in the task by the participants. Another explanation for this observation is the possibility of jitter or inconsistent timing associated with the presentation of the auditory stimuli. There is evidence to indicate that some investigators have faced issues with consistency of timing related to the presentation of auditory stimuli when using Python software. Specifically, the presence of jitter would result in the auditory stimuli being played at different inter-stimulus intervals on a trial-to-trial basis. As a result, the relevant data (i.e., the ERP) related to the stimuli would occur at different points in time, and thus averaging of these trials would result in attenuation of the ERP (i.e., via phase cancellation). The lack of data from the oddball task precluded our ability to contrast the ERPs obtained using the Flanker tasks.

A second limitation was the use of the Flanker task to collect data associated with allocation of attention. The Flanker task is quite often used for the behavioural analysis of attention. Other studies, as pointed out earlier in the introduction, have used the Flanker task to obtain ERP data for quantifying attention. These studies have mostly studied the P300 waveform. However, the late positive complex we obtained using the Flanker task did not parallel the P300. Alternatively, we possibly observed a component of attention inhibition from the ERPs obtained for the modified Flanker tasks. This finding leads us to

believe that, although the Flanker task can elicit the P300, it may not have been the best choice to study attention allocation, as it is more representative of attention inhibition. Despite this limitation, the study gives us a direction to study the basic Flanker task in greater detail to further determine what kind of cognitive processing the Flanker task represents: inhibition processes or allocation of attention.

Another limitation to our tasks was the use of familiar sounds and images as distractors in the modified Flanker tasks. The use of such stimuli appeared to initiate an altogether different processing mechanism represented by the P400. Since the P300 has an overlapping latency with the P400, the involvement of additional mental processes may have diminished any responses on the EEG that corresponded with allocation of attention. There is a potential to replace these stimuli with unfamiliar stimuli to see if that changes the late positive complex obtained from the modified Flanker tasks. For instance, using pure tones of different frequencies as auditory distractors and using a simple circle with different colours as a visual distractor can help us study the novelty of attention using the Flanker task.

Additionally, there is a possibility that choices associated with signal processing could have affected the late ERP components. For instance, the waveforms obtained end abruptly at the same point (amplitude) on each of our graphs, suggesting that the choice of filter (or more specifically the time at which the filter was applied) resulted in an artificial finding. Additionally, the epoch length chosen for analysis may have limited our ability to obtain the late ERP components (i.e., the P300). There have been reports of the

P300 appearing later than the 450 ms window post-stimuli that was used in the current study, and as such use of a longer epoch may have allowed the P300 to be obtained.

Lastly, it should be noted that the majority of the participants recruited for this study spoke English as a second language. While remote, there is a possibility that instructions were misinterpreted resulting in inaccurate task performance.

CHAPTER 7: CONCLUSION

The primary objective of this study was to design and test modified versions of the Flanker task for obtaining ERPs for the assessment of attention. The idea was to compare the ERPs elicited with these modified Flanker tasks to the more traditionally used three-stimulus auditory oddball task. The approach taken towards this objective was to include distractor stimuli in the Flanker tasks to tease apart the stimulus evaluation and response execution components of attentional processing (the P3a and P3b respectively).

The results of the study indicated that the modified Flanker tasks provided indicators for studying attention primarily through the ERP analysis of early components, including the N100-P200 complex, and not the P300 or its sub-components. Some late positive complexes were obtained using the modified Flanker tasks that could perhaps also be indicative of attentional processes. The results reflected that the modified Flanker tasks are more indicative of an inhibition process than the allocation of attention. The modified Flanker tasks were also representative of the novel component of task performance (the distractor stimuli). This was indicated through the larger N200 ERP obtained for the distractor stimuli on the modified Flanker tasks. On the other hand, we were not successful at obtaining any indicators of attention from the oddball task. Instead we obtained an N350 ERP on all trials for the oddball task, which is indicative of drowsiness during task performance. Thus, we conclude that the modified Flanker tasks were successful in providing a behavioural and an electrophysiological measure of studying novelty or a purely stimulus evaluation process and inhibition of attention that

includes response execution. On the other hand, the oddball task was found to be more monotonous and less engaging for the participants, which along with hardware issues may have resulted in an inability to obtain ERPs that were indicators of attentional processing.

The analysis of later ERP components in this study was limited due to the smaller epochs used for signal processing. As indicated above data obtained for the project could be analyzed using a longer epoch in an attempt to study whether any later ERP components were present. Additionally, there is a need to further reassess the use of Python for auditory stimuli in order to study timing effects and the potential impact on the ERP components related to the auditory stimuli. Lastly, further research needs to be done on reliability of the modified Flanker tasks and their validity in assessing the early components of ERP that have been identified to represent pre-attentive processing.

The results of this study provides a baseline for further research that can be done to study electrophysiological, and potentially structural, differences in the mechanism of attention when using different neuropsychological tasks. Additionally, this study is a platform for designing neuropsychological tasks in a way that we can study attentional processing in individuals. Owing to our results, it seems that further research can be done to study the impact of cognitive testing on pre-attentive processes and how a baseline measure for the same can be used to assess executive functions among clinical populations with attention-related disorders.

REFERENCES

Baddeley, A. D., & Hitch, G. (1974). Working memory. *Psychology of learning and motivation*, 8, 47-89.

Barkley, R. A. (1997). Behavioral inhibition, sustained attention, and executive functions: constructing a unifying theory of ADHD. *Psychological bulletin*, 121(1), 65.

Barrett, S. E., & Rugg, M. D. (1990). Event-related potentials and the semantic matching of pictures. *Brain and cognition*, 14(2), 201-212.

Bier N, Desrosiers J, Gagnon L. Cognitive training interventions for normal aging, mild cognitive impairment and Alzheimer's. *Can J Occup Ther*. 2006;73:26–35.

Black, D. S., Semple, R. J., Pokhrel, P., & Grenard, J. L. (2011). Component Processes of Executive Function—Mindfulness, Self-control, and Working Memory—and Their Relationships with Mental and Behavioral Health. *Mindfulness*, 2(3), 179-185.

Blair, C., Zelazo, P. D., & Greenberg, M. T. (2005). The measurement of executive function in early childhood. *Developmental Neuropsychology*, 28(2), 561-571.

Bougrain, L., Saavedra, C., & Ranta, R. (2012, March). Finally, what is the best filter for P300 detection?. In TOBI Workshop III-Tools for Brain-Computer Interaction-2012.

Braverman, E. R., Chen, T. J., Schoolfield, J., Martinez-Pons, M., Arcuri, V., Varshavskiy, M., & Blum, K. (2006). Delayed P300 latency correlates with abnormal test of variables of attention (TOVA) in adults and predicts early cognitive decline in a clinical setting. *Advances in therapy*, 23(4), 582-600.

Brent, G., Smith, D. B. D., & Michalewski, H. J. (1977, January). DIFFERENCES IN EVOKED-POTENTIAL IN YOUNG AND OLD SUBJECTS DURING HABITUATION AND DISHABITUATION PROCEDURES. In *Psychophysiology* (Vol. 14, No. 1, pp. 96-97). 40 WEST 20TH STREET, NEW YORK, NY 10011-4211: CAMBRIDGE UNIV PRESS.

Brown, C. R., Clarke, A. R., & Barry, R. J. (2006). Inter-modal attention: ERPs to auditory targets in an inter-modal oddball task. *International journal of psychophysiology*, 62(1), 77-86.

Bruhn, P., & Parsons, O. A. (1971). Continuous reaction time in brain damage. *Cortex*, 7(3), 278-291.

Carlson, S. M. (2005). Developmentally sensitive measures of executive function in preschool children. *Developmental neuropsychology*, 28(2), 595-616.

Carver, L. J., Meltzoff, A. N., & Dawson, G. (2006). Event-related potential (ERP) indices of infants' recognition of familiar and unfamiliar objects in two and three dimensions. *Developmental Science*, 9(1), 51-62

Cohen, J. (1988). *Statistical power analysis for the behavioral sciences* Laurence Erlbaum. *Hillsdale, NJ*.

Comerchero, M. D., & Polich, J. (1998). P3a, perceptual distinctiveness, and stimulus modality. *Cognitive Brain Research*, 7(1), 41-48.

Comerchero, M. D., & Polich, J. (1999). P3a and P3b from typical auditory and visual stimuli. *Clinical Neurophysiology*, 110(1), 24-30.

Compton, P. E., Grossenbacher, P., Posner, M. I., & Tucker, D. M. (1991). A cognitive-anatomical approach to attention in lexical access. *Journal of Cognitive Neuroscience*, 3(4), 304-312.

Cote, K. A., De Lugt, D. R., Langley, S. D., & Campbell, K. B. (1999). Scalp topography of the auditory evoked K-complex in stage 2 and slow wave sleep. *Journal of sleep research*, 8(4), 263-272.

Courchesne, E., Hillyard, S. A., & Galambos, R. (1975). Stimulus novelty, task relevance and the visual evoked potential in man. *Electroencephalography and clinical neurophysiology*, 39(2), 131-143.

Daffner, K. R., Mesulam, M. M., Holcomb, P. J., Calvo, V., Acar, D., Chabrierie, A., ... & Scinto, L. F. (2000a). Disruption of attention to novel events after frontal lobe injury in humans. *Journal of Neurology, Neurosurgery & Psychiatry*, 68(1), 18-24.

Daffner, K. R., Mesulam, M. M., Scinto, L. F. M., Acar, D., Calvo, V., Faust, R., ... & Holcomb, P. (2000b). The central role of the prefrontal cortex in directing attention to novel events. *Brain*, 123(5), 927-939.

Denckla, M. B. (1996). A theory and model of executive function: A neuropsychological perspective.

Donchin, E., Karis, D., Bashore, T.R., Coles, M.G., Gratton, G., 1986. Cognitive psychophysiology and human information processing. In: Coles, M.G.H., Donchin, E., Porges, S.W. Eds., *Psychophysiology: Systems, Processes, and Applications*. The Guilford Press, New York, pp. 244]267.

Donkers, F. C., and van Boxtel, G. J. (2004). The N2 in go/no-go tasks reflects conflict monitoring not response inhibition. *Brain Cogn.* 56, 165–176. doi: 10.1016/j.bandc.2004.04.005

Duncan, J. (1986). Disorganization of behavior after frontal lobe damage. *Cognitive Neuropsychology*, 3, 271–290.

Duncan, J., Emslie, H., Williams, P., Johnson, R., & Freer, C. (1996). Intelligence and the frontal lobe: The organization of goal-directed behavior. *Cognitive psychology*, 30(3), 257-303.

Duncan, R., Johnson, M., Swales, C., Freer, J. (1997). Frontal lobe deficits after head injury: Unity and diversity of function. *Cognitive Neuropsychology*, 14(5), 713-741.

Eimer, M. (1993). Effects of attention and stimulus probability on ERPs in a Go/Nogo task. *Biological psychology*, 35(2), 123-138.

Elliott, R. (2003). Executive functions and their disorders Imaging in clinical neuroscience. *British Medical Bulletin*, 65(1), 49-59.

Emmerson RY, Dustman RE, Shearer DE, Turner CW. 1989, P3 latency and symbol digit performance correlations in aging. *Exp Aging Res.*;15:151–15

Eriksen, B. A., & Eriksen, C. W. (1974). Effects of noise letters upon the identification of a target letter in a nonsearch task. *Perception & psychophysics*, 16(1), 143-149.

Eriksen, C. W. (1995). The Flankers task and response competition: A useful tool for investigating a variety of cognitive problems. *Visual Cognition*, 2(2-3), 101-118.

Eriksen, C. W., & Hoffman, J. E. (1972). Temporal and spatial characteristics of selective encoding from visual displays. *Perception & psychophysics*, 12(2), 201-204.

Falkenstein, M., Hohnsbein, J., & Hoormann, J. (1994a). Effects of choice complexity on different subcomponents of the late positive complex of the event-related potential. *Electroencephalography and Clinical Neurophysiology/Evoked Potentials Section*, 92(2), 148-160.

Falkenstein, M., Hohnsbein, J., & Hoormann, J. (1994a). The “N2-effect in ERP of audio-visual Go/No-go tasks (1994b). In Press

Falkenstein, M., Hohnsbein, J., Hoormann, J., & Blanke, L. (1991). Effects of crossmodal divided attention on late ERP components. II. Error processing in choice reaction tasks. *Electroencephalography and clinical neurophysiology*, 78(6), 447-455.

Falkenstein, M., Koshlykova, N. A., Kiroj, V. N., Hoormann, J., & Hohnsbein, J. (1995). Late ERP components in visual and auditory Go/Nogo tasks. *Electroencephalography and Clinical Neurophysiology/Evoked Potentials Section*, 96(1), 36-43.

Fenske, M. J., & Eastwood, J. D. (2003). Modulation of focused attention by faces expressing emotion: evidence from Flanker tasks. *Emotion*, 3(4), 327.

Fletcher, J. M., Brookshire, B. L., Landry, S. H., Bohan, T. P., Davidson, K. C., Francis, D. J.,

Levin, H.S., Brandt, M.E., Kramer, L.A., and Morris, R.D., "Attentional skills and executive functions in children wit... & Morris, R. D. (1996). Attentional skills and executive functions in children with early hydrocephalus. *Developmental Neuropsychology*, 12(1), 53-76.

Friedrich, F. J., Egly, R., Rafal, R. D., & Beck, D. (1998). Spatial attention deficits in humans: a comparison of superior parietal and temporal-parietal junction lesions. *Neuropsychology*, 12(2), 193.

Friedrich, M., & Friederici, A. D. (2005). Phonotactic knowledge and lexical-semantic processing in one-year-olds: Brain responses to words and nonsense words in picture contexts. *Journal of Cognitive Neuroscience*, 17(11), 1785-1802.

Gagneux, P., & Varki, A. (2001). Genetic differences between humans and great apes. *Molecular phylogenetics and evolution*, 18(1), 2-13.

Godefroy, O. (2003). Frontal syndrome and disorders of executive functions. *Journal of neurology*, 250(1), 1-6.

Goldberg, E. (2001). *The executive brain: Frontal lobes and the civilized mind*. Oxford University Press.

Grandmaison E, Simard M. A critical review of memory stimulation programs in Alzheimer's disease. *J Neuropsychiatry Clin Neurosci*.2003;15:130–44

Haas, L. F. (2003). Hans Berger (1873–1941), Richard Caton (1842–1926), and electroencephalography. *Journal of Neurology, Neurosurgery & Psychiatry*, 74(1), 9-9.

Harsh, J., Voss, U., Hull, J., Schrepfer, S., & Badia, P. (1994). ERP and behavioral changes during the wake/sleep transition. *Psychophysiology*, 31(3), 244-252.

Head, A. S., & PEDOE, D. T. (1990). A CHOICE-REACTION TIME TASK UTILIZING CONGRUENT AND INCONGRUENT COLOUR/WORD STIMULI: ANOTHER REACTION TO STROOP. *Perceptual and motor skills*, 71(1), 115-119.

Hillyard, S. A., Hink, R. F., Schwent, V. L., & Picton, T. W. (1973). Electrical signs of selective attention in the human brain. *Science*, 182(108), 177-180.

HILLYARD, S.A., COURCHESNE, E., KRAUSZ, H.I. and PICTON, T.W. Scalp Topography of the P3 Wave in Different Auditory Decision Tasks, In *The Responsive Brain*, edited by W. Cheyne McCallum and John R. Knott, Butterworth-Heinemann, 1976, Pages 81-87, ISBN 9780723604433

Hohnsbein, J., Falkenstein, M., Hoormann, J., & Blanke, L. (1991). Effects of crossmodal divided attention on late ERP components. I. Simple and choice reaction tasks. *Electroencephalography and clinical Neurophysiology*, 78(6), 438-446.

Hommel, B. (1997). Interactions between stimulus-stimulus congruence and stimulus-response compatibility. *Psychological Research*, 59(4), 248-260.

Houlihan, M., Stelmack, R., & Campbell, K. (1998). P300 and cognitive ability: Assessing the roles of processing speed, perceptual processing demands and task difficulty. *Intelligence*, 26, 9-25

Ibáñez, A., López, V., & Cornejo, C. (2006). ERPs and contextual semantic discrimination: degrees of congruence in wakefulness and sleep. *Brain and Language*, 98(3), 264-275

IRAGUI, V. J., Kutas, M., Mitchiner, M. R., & Hillyard, S. A. (1993). Effects of aging on event-related brain potentials and reaction times in an auditory oddball task. *Psychophysiology*, 30(1), 10-22.

ISOGLU-ALKAÇ, ÜMMÜHAN., Kedzior, K., Karamürsel, S., & Ermutlu, N. (2007). Event-related potentials during auditory oddball, and combined auditory oddball-visual paradigms. *International Journal of Neuroscience*, 117(4), 487-506.

Janowsky, J. S., Shimamura, A. P., & Squire, L. R. (1989). Source memory impairment in patients with frontal lobe lesions. *Neuropsychologia*, 27(8), 1043-1056.

Jeon, Y. W., & Polich, J. (2003). Meta-analysis of P300 and schizophrenia: Patients, paradigms, and practical implications. *Psychophysiology*, 40(5), 684-701.

Johnstone, S. J., Barry, R. J., Markovska, V., Dimoska, A., & Clarke, A. R. (2009). Response inhibition and interference control in children with AD/HD: A visual ERP investigation. *International Journal of Psychophysiology*, 72(2), 145-153.

Jones, S. H., Hemsley, D. R., & Gray, J. A. (1991). Contextual effects on choice reaction time and accuracy in acute and chronic schizophrenics. Impairment in selective attention or in the influence of prior learning?. *The British Journal of Psychiatry*, 159(3), 415-421.

Karlin, L., Martz, M. J., & Mordkoff, A. M. (1970). Motor performance and sensory-evoked potentials. *Electroencephalography and Clinical Neurophysiology*, 28(3), 307-313.

Kiehl, K. A. (2006). A cognitive neuroscience perspective on psychopathy: evidence for paralimbic system dysfunction. *Psychiatry research*, 142(2), 107-128.

Kiehl, K. A., Hare, R. D., McDonald, J. J., & Brink, J. (1999). Semantic and affective processing in psychopaths: An event-related potential (ERP) study. *Psychophysiology*, 36(6), 765-774.

Kirino, E., Belger, A., Goldman-Rakic, P., & McCarthy, G. (2000). Prefrontal activation evoked by infrequent target and novel stimuli in a visual target detection task: an event-related functional magnetic resonance imaging study. *The Journal of Neuroscience*, 20(17), 6612-6618.

Knight RT, Grabowecky M, Scabini D. 1995, Role of human prefrontal cortex in attention control. *Adv Neurol.* ;66:21–34

Knight RT. Contribution of human hippocampal region to novelty detection. 1996, *Nature.* ;383:256–259.

Kok, A. (1986). Effects of degradation of visual stimuli on components of the event-related potential (ERP) in go/nogo reaction tasks. *Biological psychology*, 23(1), 21-38.

Kornmeier, J., & Bach, M. (2009). Object perception: when our brain is impressed but we do not notice it. *Journal of vision*, 9(1), 7.

Kray, I. (2006). Aging and attention. *Lifespan cognition: Mechanisms of change*, 57.

Kutas, M., McCarthy, G., Donchin, E., 1977. Augmenting mental chronometry: the P300 as a measure of stimulus evaluation. *Science* 197, 792]795.

Lezak, M. (1995). *Neuropsychological assessment* (2nd ed.). New York: Oxford University Press.

Luck, S. J. (2005). *An introduction to the event-related potential technique (cognitive neuroscience)*

Luck, S. J. (2014). *An introduction to the event-related potential technique*. MIT press.

Luck, S. J., & Hillyard, S. A. (2000). The operation of selective attention at multiple stages of processing: Evidence from human and monkey electrophysiology. *The new cognitive neurosciences*, 687-700.

Luck, S. J., & Kappenman, E. S. (Eds.). (2011). *The Oxford Handbook of Event-Related Potential Components*. Oxford University Press.

MacLeod, Colin (2007). *Concept of Inhibition in Cognition*. Retrieved March 3, 2013.

Mangun, G. R., & Hillyard, S. A. (1991). Modulations of sensory-evoked brain potentials indicate changes in perceptual processing during visual-spatial priming. *Journal of Experimental Psychology: Human Perception and Performance*, 17(4), 1057.

McGhie, A., & Chapman, J. (1961). Disorders of attention and perception in early schizophrenia. *British Journal of Medical Psychology*, 34(2), 103-116.

Mirsky, A. F. (1987). Behavioral and psychophysiological markers of disordered attention. *Environmental health perspectives*, 74, 191.

Miyake, A., Friedman, N. P., Rettinger, D. A., Shah, P., & Hegarty, M. (2001). How are visuospatial working memory, executive functioning, and spatial abilities related? A latent-variable analysis. *Journal of Experimental Psychology: General*, 130(4), 621.

Niedermeyer, E., & da Silva, F. H. L. (Eds.). (2005). *Electroencephalography: basic principles, clinical applications, and related fields*. Wolters Kluwer Health.

Nielsen-Bohlman, L., Knight, R. T., Woods, D. L., & Woodward, K. (1991). Differential auditory processing continues during sleep. *Electroencephalography and clinical neurophysiology*, 79(4), 281-290.

Norman, D. A., & Shallice, T. (1980). Attention to action: Willed and automatic control of behavior (No. CHIP-99). California Univ San Diego, La Jolla Center for Human Information Processing.

Nunez, P. L. (1981). Electric fields of the brain: The Neurophysics of EEG. 1st ed., New York: Oxford University Press.

Ogilvie, R. D. (2001). The process of falling asleep. *Sleep Medicine Reviews*,5(3), 247-270.

Oldfield, R. C. (1971). The assessment and analysis of handedness: The Edinburgh inventory. *Neuropsychologia*, 9, 97-114.

Opitz, B. (2003). ERP and fMRI correlates of target and novelty processing. In *Detection of Change* (pp. 117-132). Springer US.

Owens, J. (1976). Aristotle: Cognition a Way of Being. *Canadian Journal of Philosophy*, 1-11.

Pelosi L, Holly M, Slade T, Hayward M, Barrett G, Blumhardt LD. 1992a, Event-related potential (ERP) correlates of performance of intelligence-tests. *Electroencephalogr Clin Neurophysiol.*;84:515–520

Pennington, B. F., & Ozonoff, S. (1996). Executive functions and developmental psychopathology. *Journal of child psychology and psychiatry*, 37(1), 51-87.

Pennington, B. F., Bennetto, L., McAleer, O., & Roberts Jr, R. J. (1996). Executive functions and working memory: Theoretical and measurement issues.

Pfefferbaum, A., Ford, J. M., Weller, B. J., & Kopell, B. S. (1985). ERPs to response production and inhibition. *Electroencephalography and clinical neurophysiology*, 60(5), 423-434.

Picton, T. W. (1992). The P300 wave of the human event-related potential. *Journal of clinical neurophysiology*, 9(4), 456-479.

Polich J. Overview of P3a and P3b. (2003), In: Polich J, editor. *Detection of change: event-related potential and fMRI findings*. Boston, MA: Kluwer; pp. 83–98

Polich, J. (1996). Meta-analysis of P300 normative aging studies. *Psychophysiology*, 33(4), 334-353.

Polich, J. (2007). Updating P300: an integrative theory of P3a and P3b. *Clinical neurophysiology*, 118(10), 2128-2148.

Polich, J., & Herbst, K. L. (2000). P300 as a clinical assay: rationale, evaluation, and findings. *International Journal of Psychophysiology*, 38(1), 3-19.

Polich, J., & Kok, A. (1995). Cognitive and biological determinants of P300: an integrative review. *Biological psychology*, 41(2), 103-146.

Polich, J., 1986a. Attention, probability, and task demands as determinants of P300 latency from auditory stimuli. *Electroencephalogr. Clin. Neurophysiol.* 63, 251]259.

Posner, M. I. (1978). *Chronometric explorations of mind*. Lawrence Erlbaum.

Posner, M. I., & Petersen, S. E. (1989). The attention system of the human brain (No. TR-89-1). WASHINGTON UNIV ST LOUIS MO DEPT OF NEUROLOGY.

Posner, M. I., Petersen, S. E., Fox, P. T., & Raichle, M. E. (1988). Localization of cognitive operations in the human brain. *Science*, 240(4859), 1627-1631.

Posner, M. I., Snyder, C. R., & Davidson, B. J. (1980). Attention and the detection of signals. *Journal of experimental psychology: General*, 109(2), 160.

Pratt, H., Berlad, I., & Lavie, P. (1999). Oddball event-related potentials and information processing during REM and non-REM sleep. *Clinical Neurophysiology*, 110(1), 53-61.

Pratt, N., Willoughby, A., & Swick, D. (2011). Effects of working memory load on visual selective attention: behavioral and electrophysiological evidence. *Frontiers in human neuroscience*, 5, 57.

Rabbitt, P. (Ed.). (1997). *Methodology of frontal and executive function*. Psychology Press.

Ridderinkhof, K. R., Band, G. P., & Logan, D. (1999). "A study of adaptive behavior: effects of age and irrelevant information on the ability to inhibit one's actions". *Acta psychologica* 101: 315–337.

Rushby JA, Barry RJ, Doherty RJ., 2005, Separation of the components of the late positive complex in an ERP dishabituation paradigm. *Clin Neurophysiol.*;116:2363–2380.

Salthouse, T. A., Atkinson, T. M., & Berish, D. E. (2003). Executive functioning as a potential mediator of age-related cognitive decline in normal adults. *Journal of Experimental Psychology: General*, 132(4), 566.

Sanders, A. F., & Lamers, J. M. (2002). The Eriksen Flanker effect revisited. *Acta Psychologica*, 109(1), 41-56.

Shallice, T., Burgess, P., & Robertson, I. (1996). The domain of supervisory processes and temporal organization of behaviour [and discussion]. *Philosophical Transactions of the Royal Society of London. Series B: Biological Sciences*, 351(1346), 1405-1412.

Simons, C. J., Sambeth, A., Krabbendam, L., Pfeifer, S., van Os, J., & Riedel, W. J. (2011). Auditory P300 and N100 components as intermediate phenotypes for psychotic disorder: Familial liability and reliability. *Clinical Neurophysiology*, 122(10), 1984-1990.

Simson, R., Vaughan Jr, H. G., & Ritter, W. (1977). The scalp topography of potentials in auditory and visual Go/NoGo tasks. *Electroencephalography and clinical neurophysiology*, 43(6), 864-875.

Sitzer DI, Twamley EW, Jeste DV. Cognitive training in Alzheimer's disease: a meta-analysis of the literature. *Acta Psychiatr Scand*.2006;114:75–90

Smith, J. L., Johnstone, S. J., & Barry, R. J. (2004). Inhibitory processing during the Go/NoGo task: an ERP analysis of children with attention-deficit/hyperactivity disorder. *Clinical Neurophysiology*, 115(6), 1320-1331.

Sokolov, E. N. (1990). The orienting response, and future directions of its development. *The Pavlovian Journal of Biological Science*, 25, 142-150.

Sperry, R. W. (1988). Psychology's mentalist paradigm and the religion/science tension. *American Psychologist*, 43(8), 607.

Spreng, M. (1980) Objective neuro-electrophysiological evaluation of noise effects. In: *Noise as a Public Health Problem*, Proc. Third Int. Congr., Tobias, J.V., Jansen, G.&Ward, W.D. eds., ASHA-Report, Rockville, Maryland, pp.254-260

Squires, N. K., Squires, K. C., & Hillyard, S. A. (1975). Two varieties of long-latency positive waves evoked by unpredictable auditory stimuli in man. *Electroencephalography and clinical neurophysiology*, 38(4), 387-401.

Stige, S., Fjell, A. M., Smith, L., Lindgren, M., & Walhovd, K. B. (2007). The development of visual P3a and P3b. *Developmental neuropsychology*, 32(1), 563-584.

Strayer, D. L., & Kramer, A. F. (1990). Attentional requirements of automatic and controlled processing. *Journal of Experimental Psychology: Learning, Memory, and Cognition*, 16(1), 67.

Strobel, A., Debener, S., Sorger, B., Peters, J. C., Kranczioch, C., Hoehstetter, K., ... & Goebel, R. (2008). Novelty and target processing during an auditory novelty oddball: a simultaneous event-related potential and functional magnetic resonance imaging study. *Neuroimage*, 40(2), 869-883.

Sutton, S., Braren, M., Zubin, J., & John, E. R. (1965). Evoked-potential correlates of stimulus uncertainty. *Science*, 150(3700), 1187-1188.

Thivierge, S., Simard, M., Jean, L., & Grandmaison, É. (2008). Errorless learning and spaced retrieval techniques to relearn instrumental activities of daily living in mild Alzheimer's disease: A case report study. *Neuropsychiatric disease and treatment*, 4(5), 987.

Towse, J. N., Lewis, C., & Knowles, M. (2007). When knowledge is not enough: The phenomenon of goal neglect in preschool children. *Journal of Experimental Child Psychology*, 96(4), 320-332.

Uemura, K., Oya, T., & Uchiyama, Y. (2013). Effects of speed and accuracy strategy on choice step execution in response to the Flanker interference task. *Human movement science*, 32(6), 1393-1403.

Van Zomeren AH, Van DenBurg W. (1985) Residual complaints of patients two years after severe head injury. *Journal of Neurology Neurosurgery and Psychiatry*, 48:21–8.

Volpe, U., Mucci, A., Bucci, P., Merlotti, E., Galderisi, S., & Maj, M. (2007). The cortical generators of P3a and P3b: a LORETA study. *Brain research bulletin*, 73(4), 220-230.

W. Grey Walter, R. Cooper, H.J. Crow, W.C. McCallum, W.J. Warren, V.J. Aldridge, W. Storm van Leeuwen, A. Kamp, (1967) Contingent negative variation and evoked responses recorded by radio-telemetry in free-ranging subjects, *Electroencephalography and Clinical Neurophysiology*, Volume 23, Issue 3, Pages 197-206

Waszak, F., Li, S. C., & Hommel, B. (2010). The development of attentional networks: cross-sectional findings from a life span sample. *Developmental psychology*, 46(2), 337.

Wickens, C., Kramer, A., Vanasse, L., & Donchin, E. (1983). Performance of concurrent tasks: A psychophysiological analysis of the reciprocity of information-processing resources. *Science*.

Wilkins, A. J., Shallice, T., & McCarthy, R. (1987). Frontal lesions and sustained attention. *Neuropsychologia*, 25(2), 359-365.

Zelazo, P. D., Carter, A., Reznick, J. S., & Frye, D. (1997). Early development of executive function: A problem-solving framework. *Review of general*

APPENDIX

Appendix 1 Screening form

Potential Pts. Code:	Date:	
Screened By:	Age:	Gender:

For this study to be right for you, I'm going to tell you some things that need to apply. Please tell me if any of these statements do not apply to you. We are looking for participants who:

Criteria	<input type="checkbox"/>
Are between 20-29 years of age	
Normal to corrected to normal vision	
Have no metal in the head or face that is not removable	
No history of neurological, psychological or psychiatric illness	
Have jaw injury (discomfort associated with EEG cap strap)	
Have unhealed wounds on head or around eyes	
Have tattoos on face around eyes	

OUTCOME OF SCREEN			
1. Patient meets criteria	<input type="checkbox"/> Yes	<input type="checkbox"/> No	Comments
2. Patient agrees to participate	<input type="checkbox"/> Yes	<input type="checkbox"/> No	Comments
Reason for Ineligibility			
Comments			

Appendix 2

Edinburgh Handedness Inventory (by Oldfield, R.C., 1971)

Participant Code: _____

Please indicate with a check your preference in using your left or right hand in the following tasks.

Where the preference is so strong you would never use the other hand, unless absolutely forced to, put two checks.

If you are indifferent, put one check in each column.

Some of the activities require both hands. In these cases, the part of the task or object for which hand preference is wanted is indicated in parentheses.

Task / Object	Left Hand	Right Hand
1. Writing		
2. Drawing		
3. Throwing		
4. Scissors		
5. Toothbrush		
6. Knife (without fork)		
7. Spoon		
8. Broom (upper hand)		
9. Striking a Match (match)		
10. Opening a Box (lid)		
Total checks:	LH =	RH =
Cumulative Total	CT = LH + RH =	
Difference	D = RH - LH =	
Result	R = (D / CT) \square 100 =	
Interpretation: (Left Handed: R < -40, Ambidextrous: -40 - +40, Right Handed: R > +40)		

APPENDIX 3

Consent form



Capital Health



CONSENT TO TAKE PART IN A RESEARCH STUDY Participant Information

CONSENT FORM FOR NON-DISABLED SUBJECTS WILLING TO PARTICIPATE IN THE STUDY

STUDY TITLE: *Exploring potential synergistic effects of aerobic exercise and cognitive exercise on cognition after stroke: A pilot randomized controlled trial.*

CLINICAL STUDY REGISTRATION NUMBER: NCT01674790

PRINCIPAL INVESTIGATOR:

Dr. Marilyn MacKay-Lyons

Associate Professor

School of Physiotherapy and Medicine (Physical Medicine and Rehabilitation)

Dalhousie University

Room 405, Forrest Building, 5869 University Avenue

PO Box 15,000 Halifax, NS; B3H 4R2

(902) 494-2632

m.mackay-lyons@dal.ca

ASSOCIATE INVESTIGATORS:

Please see the attached Research Team Contact Page for a full list of the investigators for this trial.

FUNDING AGENCIES:

*Capital District Health Authority Research Fund
Faculty of Health Professions, Dalhousie University
Capital Health Research Fund, Capital District Health Authority*

1. INTRODUCTION

You have been invited to take part in a research study. Taking part in this study is voluntary. It is up to you to decide whether to be in the study or not. Before you decide, you need to understand what the study is for, what risks you might take and what benefits you might receive. This consent form explains the study.

Please read this carefully. Take as much time as you like. If you like, take it home to think about for a while. Mark anything you don't understand, or want explained better. After you have read it, please ask questions about anything that is not clear.

The researchers will:

- Discuss the study with you
- Answer your questions
- Keep confidential any information which could identify you personally
- Be available during the study to deal with problems and answer questions

If you decide not to take part or if you leave the study early, your usual health care will not be affected.

2. WHAT IS THE PURPOSE OF THIS STUDY?

People who have experienced a stroke often have problems with attention, memory and thinking. These problems are often referred to as 'cognitive impairments'. Such impairments are common, often lifelong and can interfere with recovery and quality of life after stroke. Cognitive exercises have been shown to improve these impairments after stroke. Aerobic exercise is any physical activity that makes a person breathe harder than normal for an extended period of time. Such exercise has also been shown to improve cognition post-stroke. The main part of this study investigates the combined effects of cognitive and aerobic exercise on reducing cognitive impairments after stroke. The purpose of your participation in the study is to allow us to collect normative data regarding the tools we use to test cognition. This normative data allows us to compare data collected from patients who have had a stroke.

3. WHAT IS BEING TESTED?

In this part of the larger study we are collecting data from younger people who have not had a stroke, on three different cognitive tests.

4. WHY AM I BEING ASKED TO JOIN THIS STUDY?

You are being asked to join the study because you are between 18-29 years of age or older, have never had a stroke, have never noticed any problems with memory or thinking, and are free of any known neurological or psychiatric illnesses.

5. HOW LONG WILL I BE IN THE STUDY?

If you agree, you will be asked to participate in a single 2.5 hour long session.

6. HOW MANY PEOPLE WILL TAKE PART IN THIS STUDY?

This study is only being done here at Capital Health. For this part of the study we plan to enroll a total of 40 non-disabled participants.

7. HOW IS THE STUDY BEING DONE?

The larger study examines the benefits gained by post-stroke participants when using physical and cognitive exercise. For your part of the study, we will be obtaining information from cognitive assessment tools being used in the larger study. These tools are being used to measure the behavioral parts of attention and the brain activity associated with it. If you agree to participate, you will be asked to attend a single session wherein you will perform 3 modified cognitive tasks while the assessor obtains a recording of your brain activity (through electroencephalography). The session will last for approximately 2.5 hours.

8. WHAT WILL HAPPEN IF I TAKE PART IN THIS STUDY?

If you want to be in this study and sign this consent form, you will be asked to have some tests done to see if you can take part. This is called screening. It is possible that the tests will show that you can't be in the study. For this purpose, you will be requested to fill in a screening form wherein you will have to answer a few questions about your current health status. This screening form will allow the investigators to decide whether you are a good match for inclusion in the study or not. Once the screening is complete you will be requested to complete a participant background information form that will be kept confidential.

As part of the experiment, you will be doing three tasks that are computer based. There will be a screen in front of you and you will need to respond to stimuli such as arrows or tones. During each test we will record brain activity using electroencephalography (EEG). We will also record your responses to each of the three tasks. Each task will approximately take 20 minutes and you will be provided ample amount of breaks in between. So you will be performing the actual experiment for at most an hour and a half.

As mentioned above, brain activity will be examined using EEG that records electrical activity (or brain activation) along the scalp. This testing will be done during the 3 computer based tasks mentioned earlier. The testing will be done in the Laboratory for Brain Recovery and Function in the School of Physiotherapy at Dalhousie University.

EEG involves placing a specially designed cap called a *QuikCap* on the head so that electrodes (64 in total) sit on top of the scalp and allow for brain activity to be measured. Other electrodes (6) will be placed around your eyes and behind the ears to keep in check

your eye movements. *QuikCaps* and the free electrodes are cleaned following each use. A number of sizes are available for the *Quick Cap*, to ensure a comfortable fit. The *QuickCap* is placed on the head, hair under each electrode is gently moved out of the way using a new, disposable blunt needle and the gel reservoirs are filled with the electrode gel.

9. ARE THERE RISKS TO THE STUDY?

There are risks with this, or any study. To give you the most complete information available, we have listed many *possible* risks, which may appear alarming. We do not want to alarm you but we do want to make sure that if you decide to try the study, you have had a chance to think about the risks carefully. Please also be aware that there may be risks in participating in this study that we do not know about yet.

There is minimal risk related to the use of EEG. All of the electrodes lie on top of the skin and do not actually contact it. A conductive gel provides the contact between the skin and the electrodes. In uncommon instances (1 or more out of every 10,000 people but less than 1 out of every 1000 people have experienced the following) it is possible that your skin may be sensitive to the conductive gel, alcohol or adhesive used in the application of the electrodes. In such cases a rash or reddening of the skin is possible but usually goes away in less than 24 hours.

The process of preparing the EEG electrodes may be mildly uncomfortable. This is because small areas of your scalp where the electrodes are will be prepared using a new, disposable blunt needle. The blunt needle is used to move the hair under the electrode out of the way as well as to fill the electrode with gel. During this process, it is possible for the blunt needle to make contact with your scalp, which may cause discomfort. We try to make this discomfort as small as possible by asking you how it feels while we are getting the electrodes ready. This way we can make sure a comfortable level of contact is used. A sink for washing gel from your skin and hair is available, and we will provide clean towels to do this (although you may also bring your own if you prefer). If you are unable to wash your hair in the sink (or if you prefer not to) you may wait until you reach your home and then wash the gel off in the shower. Any shampoo will get the gel out of your hair.

10. WHAT HAPPENS AT THE END OF THE STUDY?

At the end of the study you can ask any additional questions you might have about the study. We can also provide you with a summary of the results when the study is finished, upon request.

11. WHAT ARE MY RESPONSIBILITIES?

As a study participant you will be expected to:

- Follow the directions of the Principal Investigator
- Report all medications being taken or that you plan on taking
- Report any changes in your health to the Principal Investigator
- Report any problems you experience that you think might be related to participating in the study

12. CAN I BE TAKEN OUT OF THE STUDY WITHOUT MY CONSENT?

Yes. You may be taken out of the study by the Principal Investigator or the Research Ethics Board at any time, if:

- You cannot tolerate the assessment sessions
- You do not, or are unable to, follow the directions of the Principal Investigator
- In the opinion of the Principal Investigator you are experiencing side effects that are harmful to your health or well-being
- There is new information that shows that being in this study is not in your best interests

The funding agencies, the Capital Health Research Ethics Board, or the Principal Investigator have the right to stop patient recruitment or cancel the study at any time.

13. WHAT ABOUT NEW INFORMATION?

It is possible that new information may become available while you are in the study or prior to it beginning that may change whether you can take part in the study. You will be told about any information that might affect your health, welfare or willingness to stay in the study and will be asked whether you wish to continue taking part in the study or not.

14. WILL IT COST ME ANYTHING?

Compensation

You will be compensated for parking for up to a maximum of \$13, which is the whole day parking rate at the IWK. You will have to present your parking chit or a receipt in order to receive reimbursement. You will also be provided with some juice and snacks during breaks in the experiment. There is no charge for the assessments.

Research-Related Injury

If you become ill or injured as a direct result of participating in this study, necessary medical treatment will be available at no additional cost to you. Your signature on this form only indicates that you have understood to your satisfaction the information regarding your participation in the study and agree to participate in the study. In no way does this waive your legal rights nor release the Principal Investigator, the research team or involved institutions from their legal and professional responsibilities.

15. WHAT ABOUT MY RIGHT TO PRIVACY AND CONFIDENTIALITY?

Protecting your privacy is an important part of this study. Every effort to protect your privacy will be made. No identifying information (such as your name or hospital number) will be sent outside of this health care facility. If the results of this study are presented to the public, nobody will be able to tell that you were in the study.

However, complete privacy cannot be guaranteed. For example, the investigator may be required by law to allow access to research records. A copy of this consent form will be put in your health record. Your family doctor may be told that you are taking part in this study.

When you sign this consent form, you give us permission to:

- Collect information from you
- Share information with the people conducting the study
- Share information with the people responsible for protecting your safety while participating in this research

Access to Records

The principal investigator and members of the research team will see health and study records that identify you by name. Others who might view your records include:

- The Research Ethics Board and people working for or with the Research Ethics Board

Use of Your Study Information

The research team will collect and use only the information they need to judge the safety and usefulness of the study procedures.

This information will include your:

- Age
- Gender
- Date of Birth (month and year)
- Information from study questionnaires

Your name and contact information will be kept secure by the research team in the locked office of the Principal Investigator. It will not be shared with others without your permission. Information will be kept for 7 years as required by Capital Health.

After your part in the study ends, we may continue to review your health records for safety and data accuracy until the study is finished. Information collected and used by the research team will be stored at the Nova Scotia Rehabilitation Centre. The Principal Investigator is the person responsible for keeping it secure.

The Quality Assurance auditor for Capital Health may also contact you personally for quality assurance purposes.

Your Access to Records

You may ask the Principal Investigator to see the information that has been collected about you. You may ask to make corrections to this information by talking with a member of the research team.

16. WHAT IF I WANT TO QUIT THE STUDY?

If you choose to participate and later decide to change your mind, you can say no and stop your participation in the research at any time. If you decide to withdraw from this study by providing notice to the Principal Investigator, the data that we have collected from you will only be made available up to the point of withdraw. The above agencies, including the study sponsor, will only look at and use study related research records up to the point of your withdraw from the study, except where it is necessary to ensure the study is scientifically reliable.

17. DECLARATION OF FINANCIAL INTEREST

The funding agencies are reimbursing the Principal Investigator and/or the Principal Investigator's institution to conduct this study. The amount of payment is sufficient to cover the costs of conducting the study.

19. WHAT ABOUT QUESTIONS OR PROBLEMS?

For further information about the study call **Dr. Marilyn MacKay-Lyons**. Dr. MacKay-Lyons is in charge of this study at this hospital (the "Principal Investigator"). Dr. MacKay-Lyons' work telephone number is (902) 494-2632. If you can't reach the Principal Investigator, please refer to the attached Research Team contact page for a full list of the people you can contact for further information about the study.

Please call the Principal Investigator the next business day to tell them about the possible side effects or other medical problems you experienced.

The Principal Investigator is Dr. Marilyn MacKay-Lyons, Telephone: (902) 494-2632.

20. WHAT ARE MY RIGHTS?

After you have signed this consent form you will be given a copy.

If you have any questions about your rights as a research participant, contact the **Patient Representative** at **(902) 473-2133**.

In the next part you will be asked if you agree (consent) to join this study. If the answer is “yes”, you will need to sign the form.

21. CONSENT FORM SIGNATURE PAGE

I have reviewed all of the information in this consent form related to the trial called:

Exploring potential synergistic effects of aerobic exercise and cognitive exercise on cognition after stroke: A pilot randomized controlled trial.

I have been given the opportunity to discuss this study. All of my questions have been answered to my satisfaction.

I agree that my study information may be used as described in this consent form.

This signature on this consent form means that I agree to take part in this study. I understand that I am free to withdraw at any time without affecting my future care.

_____	_____	___ / ___ / ___
Signature of Participant	Name (Printed)	Year Month Day*

_____	_____	___ / ___ / ___
Witness to Participant's Signature	Name (Printed)	Year Month Day*

_____	_____	___ / ___ / ___
Signature of Investigator	Name (Printed)	Year Month Day*

_____	_____	___ / ___ / ___
-------	-------	-----------------

Signature of Person Conducting

Name (Printed)

Year Month Day*

Consent Discussion

**Note: Please fill in the dates personally*

I Will Be Given A Signed Copy of This Consent Form

Appendix 4
Participant Background Information

PARTICIPANT BACKGROUND INFORMATION		
Participant Code:	Investigator:	Date:
DOB (mm/yyyy):	Gender (check):	Male Female
PARTICIPANT CONTACT INFORMATION		
Telephone:	Email Address:	

Comments:
