

**REVITALIZING VANCOUVER'S JAPANTOWN:
AN ARCHITECTURAL RESPONSE TO JAPANESE FOOD**

by

Benjamin Tsuyoshi Tiffin

Submitted in partial fulfilment of the requirements
for the degree of Master of Architecture

at

Dalhousie University
Halifax, Nova Scotia
July 2012

© Copyright by Benjamin Tsuyoshi Tiffin, 2012

DALHOUSIE UNIVERSITY
SCHOOL OF ARCHITECTURE

The undersigned hereby certify that they have read and recommend to the Faculty of Graduate Studies for acceptance a thesis entitled “REVITALIZING VANCOUVER’S JAPANTOWN: AN ARCHITECTURAL RESPONSE TO JAPANESE FOOD” by Benjamin Tsuyoshi Tiffin in partial fulfilment of the requirements for the degree of Master of Architecture.

Dated: July 10, 2012

Supervisor: _____

Reader: _____

Reader: _____

DALHOUSIE UNIVERSITY

Date: July 10, 2012

AUTHOR: Benjamin Tsuyoshi Tiffin

TITLE: REVITALIZING VANCOUVER'S JAPANTOWN: AN ARCHITECTURAL
RESPONSE TO JAPANESE FOOD

DEPARTMENT OR SCHOOL: School of Architecture

DEGREE: MArch

CONVOCATION: October

YEAR: 2012

Permission is herewith granted to Dalhousie University to circulate and to have copied for non-commercial purposes, at its discretion, the above title upon the request of individuals or institutions. I understand that my thesis will be electronically available to the public.

The author reserves other publication rights, and neither the thesis nor extensive extracts from it may be printed or otherwise reproduced without the author's written permission.

The author attests that permission has been obtained for the use of any copyrighted material appearing in the thesis (other than brief excerpts requiring only proper acknowledgment in scholarly writing), and that all such use is clearly acknowledged.

Signature of Author

CONTENTS

ABSTRACT	v
ACKNOWLEDGEMENTS.....	vi
GLOSSARY	vii
CHAPTER 1: INTRODUCTION.....	1
QUESTION.....	1
CONTEXT.....	1
Japantown / Oppenheimer.....	1
History of Japantown	2
Present Condition	11
TRANSLATING EAST TO WEST	12
PROCESS AND RITUAL IN JAPANESE CULTURE	13
CHAPTER 2: DESIGN.....	16
SITE ANALYSIS.....	16
JAPANTOWN TYPOLOGY.....	19
USER GROUPS	30
<i>BENTO</i> KITCHEN AND LIBRARY (SITE 1)	33
<i>IZAKAYA</i> AND MARKET (SITE 2)	46
DEVELOPMENT OF URBAN SPACES.....	58
<i>YATAI</i>	67
CHAPTER 3: CONCLUSION	76
REFERENCES	78
APPENDIX: LESSONS FROM CHINATOWN.....	80

ABSTRACT

This thesis endeavors to create an architecture that will contribute to the revitalization of Vancouver's Japantown, mending severed cultural ties between the community and this historically significant neighborhood. Building upon the success of the Powell Street Japanese Cultural Festival, this project proposes a series of architectural interventions that will re-establish a Japanese-Canadian presence and serve as the catalyst for future phases of development.

Focusing on the processes and rituals that permeate Japanese culture, the design seeks to celebrate the act of making at both the neighborhood and building scales. The initial phase of development concentrates on the preparation and consumption of Japanese foodstuffs and their potential to mitigate existing urban maladies.

ACKNOWLEDGEMENTS

Thank you....

Steve Parcell for your tireless support, insightful suggestions and timely comic relief. It is always a delight working with you and I cannot begin to express my appreciation for all your help and guidance over the years.

Susan Fitzgerald for your brilliant design advice and enthusiastic encouragement. It was a pleasure and a privilege to work with you.

GLOSSARY

Bento - A single-portion takeout or home-packed meal common in Japanese cuisine. A traditional *bento* consists of rice, fish or meat, and one or more pickled or cooked vegetables, usually in a box-shaped container.

Hanami - The traditional Japanese custom of enjoying the beauty of flowers, “flower” in this case almost always meaning cherry blossoms (*sakura*) or (less often) plum blossoms (*ume*)

Issei - First-generation Japanese immigrants (subsequent generations are known as *nisei*, *yonsei*, etc.)

Izakaya - The name *izakaya* is a compound word consisting of *i* (to stay) and *sakaya* (*sake* shop).

Mikoshi - A divine palanquin (often improperly translated as portable Shinto shrine). Shinto followers believe that it serves as the vehicle to transport a deity in Japan while moving between main shrine and temporary shrine during a festival or when moving to a new shrine.

Nisei - Second-generation Japanese immigrants

Obon - A Japanese Buddhist custom to honor the spirits of one’s ancestors. This Buddhist-Confucian custom has evolved into a family reunion holiday during which families revisit places of ancestral heritage.

Ramen - Unlike the packaged variety most widely consumed in North America, Japanese *ramen* is a rich, highly complex, labor intensive noodle soup. Adapted from Chinese noodle soups in the early 20th century, this dish has

become synonymous with Japanese cuisine.

Shinachika - Young bamboo shoots often found in *ramen* or pickled in *bento*.

Shogatsu - The equivalent of Japanese New Year is the most important holiday in Japanese culture. Years are traditionally viewed as completely separate, with each new year providing a fresh start. Stores close for three days so families can spend time together and enjoy a number of culturally significant foodstuffs.

Tonkatsu - Pork cutlet, pounded thin and breaded with *panko*, then fried in a shallow pan.

Tonkotsu - A rich, pork-based form of *ramen* that is particularly popular in the southern regions of Japan

Torii - A traditional Japanese gate most commonly found at the entrance of or within a Shinto shrine, where it symbolically marks the transition from the profane to the sacred. They are also commonly used throughout Japan to mark the entrance into cherished spaces within a prefecture.

Yakitori - refers specifically to skewered and grilled chicken

Yakiniku - A Japanese style of grilling bite-sized meat (usually beef, chicken and offal) and vegetables on gridirons or griddles over flame or wood charcoals carbonized by dry distillation.

Yatai - A small, mobile food stall in Japan typically selling *ramen* or other food. The name literally means “shop stand.”

CHAPTER 1: INTRODUCTION

How a people cook and how a people eat is one the most powerful ways they have to express and preserve their cultural identity. (Pollan 2009, 57)

QUESTION

How can an architecture defined by “making” serve as a catalyst for the renewal of Vancouver’s Japantown?

CONTEXT

Japantown / Oppenheimer

Vancouver’s Japantown (also known as Oppenheimer) is a small neighborhood located on the eastern edge of the city’s downtown core. One of the city’s oldest neighborhoods, Japantown developed in tandem with its historic neighbor to the west, Gastown. However, since the internment and forced relocation of the Japanese-Canadian community in 1942, the area has failed to develop a coherent identity. Recent decades have seen the crime, drugs and prostitution of Vancouver’s Downtown East Side (DTES) spill into Japantown, further eroding the few remaining positive aspects of this once vibrant community.

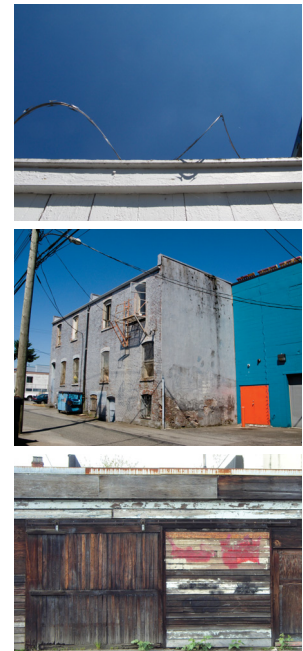

From top: ubiquitous razor wire in Japantown, typical SRO, underutilized alley space.



Japantown is located minutes away from the more celebrated regions of Vancouver's downtown core.

History of Japantown

Few traces remain of Vancouver's once thriving Japantown. The story of this neighborhood's inception, rise and sudden decline remains an obscure historical reference fading with each passing generation. It is still possible to find remnants of the area's storied past, but the meanings of these artifacts, buildings and festivals have become largely disconnected from their origin.

The history of Japantown can be divided into four major periods dating back to European settlement: 1) early immigration, 2) growth and development, 3) internment, 4) re-development and re-definition.



From top: Sumo match in Oppenheimer Park, Morimoto store entrance, Komura store entrance, Japanese Hall

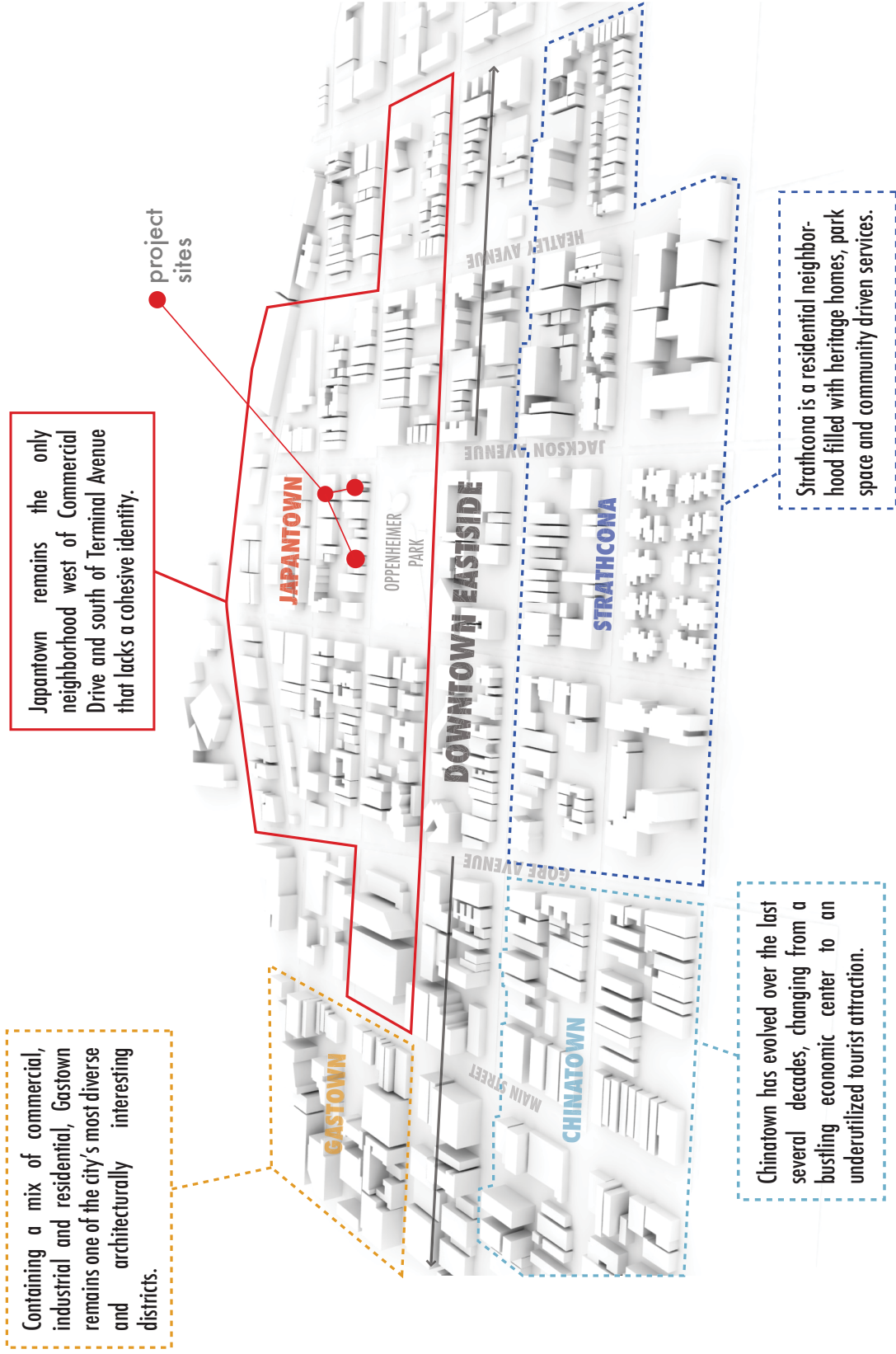

Early Immigration

European settlers began development of the Gastown/Japantown area in the 1860s, but it was not until the completion of the CPR transcontinental rail line in the late 1880s that the population began to grow. In 1887 Japanese immigrants, all young men, began to arrive in Vancouver, seeking work at the sawmills and on fishing boats. These early immigrants were desperate to escape the grinding poverty concomitant with the Meiji Restoration and willing to work long hours for little pay (Taylor 2004, 13). Japanese laborers quickly became renowned for their industrious nature and low cost, leading to an influx of additional men. Japantown was the obvious home for this new wave of immigrants, based on its proximity to the sawmill and harbor, as well as the comfort of their fellow countrymen.

As the Japanese and Chinese populations grew, so did xenophobic sentiments amongst Vancouverites. The Anti-Asian riots of 1907 were the most violent exhibition of this growing fear, but the discrimination continued long after the shop fronts were repaired.

Growth and Development

By 1910 the demographic of Japantown had begun to change. Laborers who were able to save enough money brought their families to Vancouver while young single men sent for brides from Japan. This shift led to a more vibrant and diverse community as gambling clubs and low quality tenement housing were replaced with family businesses and houses. This shift in demographic was accompanied by an increase in land ownership by Japanese and led to the creation of cultural associations and Japanese schools.

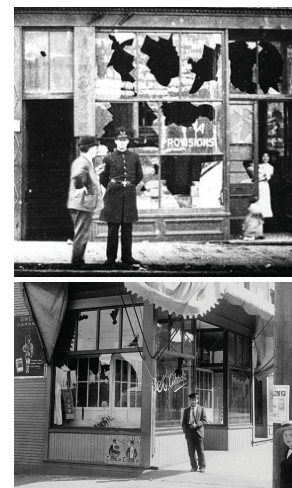

Post-riot shop fronts in Japantown 1907. (Royal British Columbia Museum)

By the 1920s Japantown was one of the major centers of Vancouver, with Powell Street serving as its commercial thoroughfare. More than half of all businesses located on Powell Street were either operated or owned by Japanese Canadians, and Oppenheimer Park was the celebrated home to the Asahi, Japantown's soon to be famous baseball team. Despite the difficult economic times being experienced elsewhere in the city, Japantown was prospering. This exacerbated existing anti-Japanese sentiment amongst struggling Vancouverites and ramped up rhetoric amongst racist politicians calling for a stop to this spreading "yellow fever." Despite the unsavory treatment by many Vancouverites the Japanese continued to be well respected by the Salish community, the original occupants of the area, and their Chinese neighbors to the south (Birmingham and Wood 2008, 44).

Internment

On December 8, 1941, one day after Japanese pilots dropped bombs on Pearl Harbor and the United States declared war on Japan, the Canadian government seized all Japanese property. This would mark the beginning of a tumultuous four-year period for the Japanese community. Nearly 8,000 men were moved to a temporary internment camp located in the stables of the nearby Hastings racetrack while women and children were subject to a strict curfew and prevented from leaving the Japantown area.

For the 8,000 Japanese Canadians who passed through it between March and September [1942] Hastings Park was the epitome of discomfort and humiliation. (Taylor 2004, 29)

At the same time that RCMP officers were searching out and detaining Japanese men, government officials were



From top: Asahi baseball team at Oppenheimer; Japanese Hall opening; looking west down Powell St - 200 Block. (Royal British Columbia Museum)

seizing all assets accumulated by the Japanese community. This included thousands of vehicles, fishing boats, store inventory and property.

After spending nearly eight months in ill-equipped stables Japanese-Canadians, women and children included, were moved to long-term internment camps in the interior of British Columbia. These camps, made up of tents and poorly insulated cabins, would serve as their home for the remainder of the war. During this period the government of British Columbia began auctioning off property seized from the Japanese community as a means of paying for the internment. The entire Japanese fleet of fishing boats were sold at a fraction of their market value and property was given away to prominent Vancouverites for future development (Taylor 2004, 68). This contradicted earlier promises by the government that all property would be returned once internment ended.



NOTICE TO ALL JAPANESE PERSONS AND PERSONS OF JAPANESE RACIAL ORIGIN

TAKE NOTICE that under Orders Nos. 21, 22, 23 and 24 of the British Columbia Security Commission, the following areas were made prohibited areas to all persons of the Japanese race:—

LULU ISLAND (including Steveston)	SAPPERTON
SEA ISLAND	BURQUITLAM
EBURNE	PORT MOODY
MARPOLE	IOCO
DISTRICT OF QUEENSBOROUGH	PORT COQUITLAM
CITY OF NEW WESTMINSTER	MAILLARDVILLE
	FRASER MILLS

AND FURTHER TAKE NOTICE that any person of the Japanese race found within any of the said prohibited areas without a written permit from the British Columbia Security Commission or the Royal Canadian Mounted Police shall be liable to the penalties provided under Order in Council P.C. 1665.

AUSTIN C. TAYLOR,
Chairman,
British Columbia Security Commission

From top: Hastings Park bunks; Japanese man being detained; list of prohibited regions (Royal British Columbia Museum)

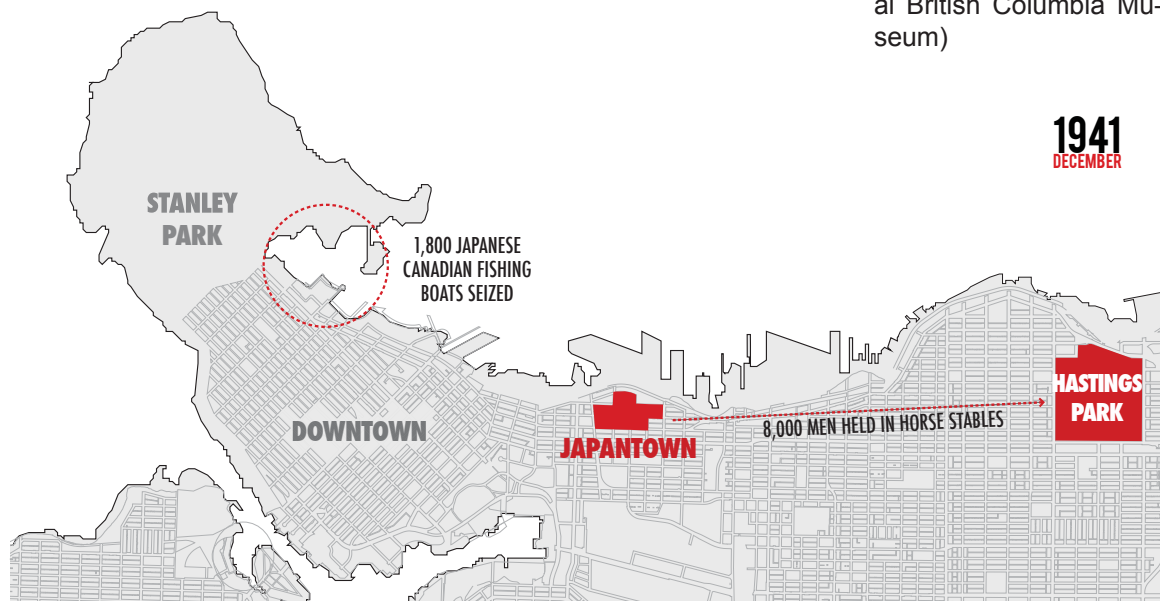

1941
DECEMBER

Detainment and temporary internment

These anti-Japanese policies continued after internment ended and were spearheaded by senior cabinet minister Ian Mackenzie. Mackenzie's infamous campaign promise of "Not a Jap from the Rockies to the Sea" was fulfilled in 1945. Japanese who wanted to remain in Canada were forced to relocate east of the Rockies to predetermined cities or return to Japan, a country that was both decimated and foreign. Despite public outcry and appeals to the Supreme Court of Canada this policy of repatriation and forced relocation remained until 1949. By this time the majority of Japanese-Canadians had moved east or repatriated. This continued racism was in sharp contrast to the treatment of Japanese in America who were given back their property and allowed to return to their former homes (Robinson 2009, 47). In all, more than 10,000 Japanese, many Canadian born, opted to return to Japan.

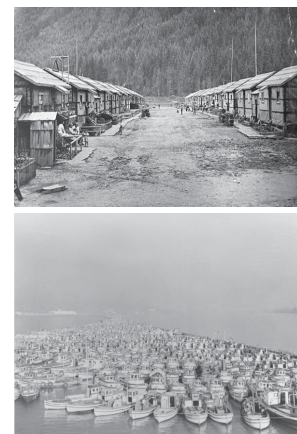

From top: Tashme internment camp; seized fishing boats in Coal Harbor (Royal British Columbia Museum)

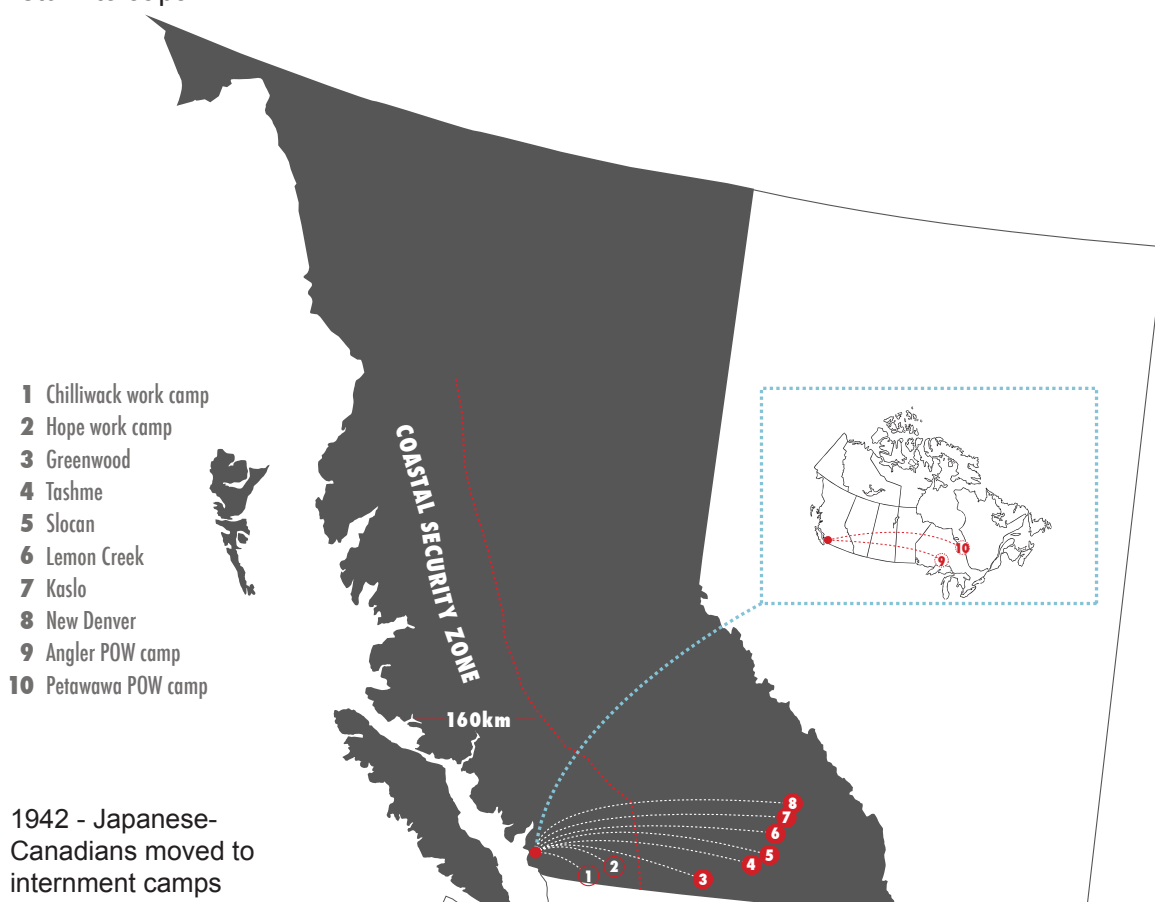

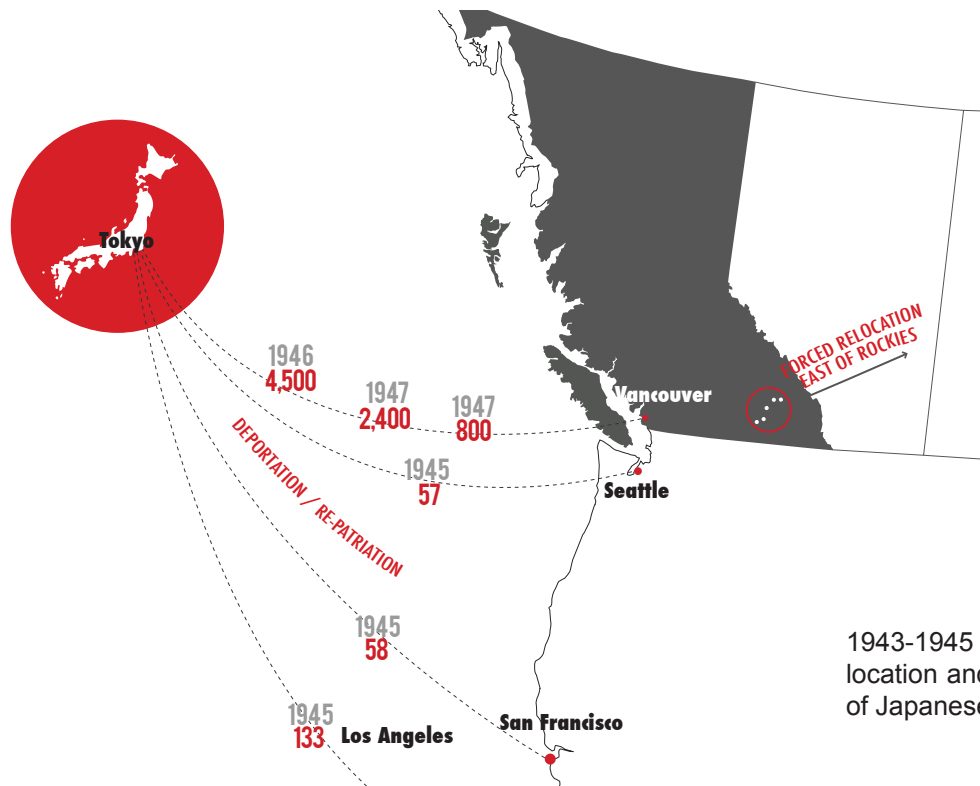

1943-1945 forced relocation and deportation of Japanese-Canadians

Re-development and Re-definition

The removal of more than 12,000 Japanese residents from the Japantown area devastated the community (Taylor 2004, 89). Entire blocks became vacant and the once vibrant Powell Street business district was dead. In the post-war years the City of Vancouver tried to address this sudden decline by rezoning the area as light industrial and building a number of large warehouses on the vacated properties. This strategy, although initially successful, failed to gain traction as manufacturers moved towards the periphery of the city in search of cheaper rent.

As industry moved out of Japantown and drugs spread throughout Vancouver's DTES, Japantown became a magnet for drug activity, prostitution and crime. Attempts to mitigate these problems have produced negligible results and in most cases only exacerbated existing conditions.



From top: Japanese man awaits his relocation destination; a woman proudly points to anti-Japanese message - Kamloops. (Royal British Columbia Museum)



Early growth sparked by Hastings sawmill

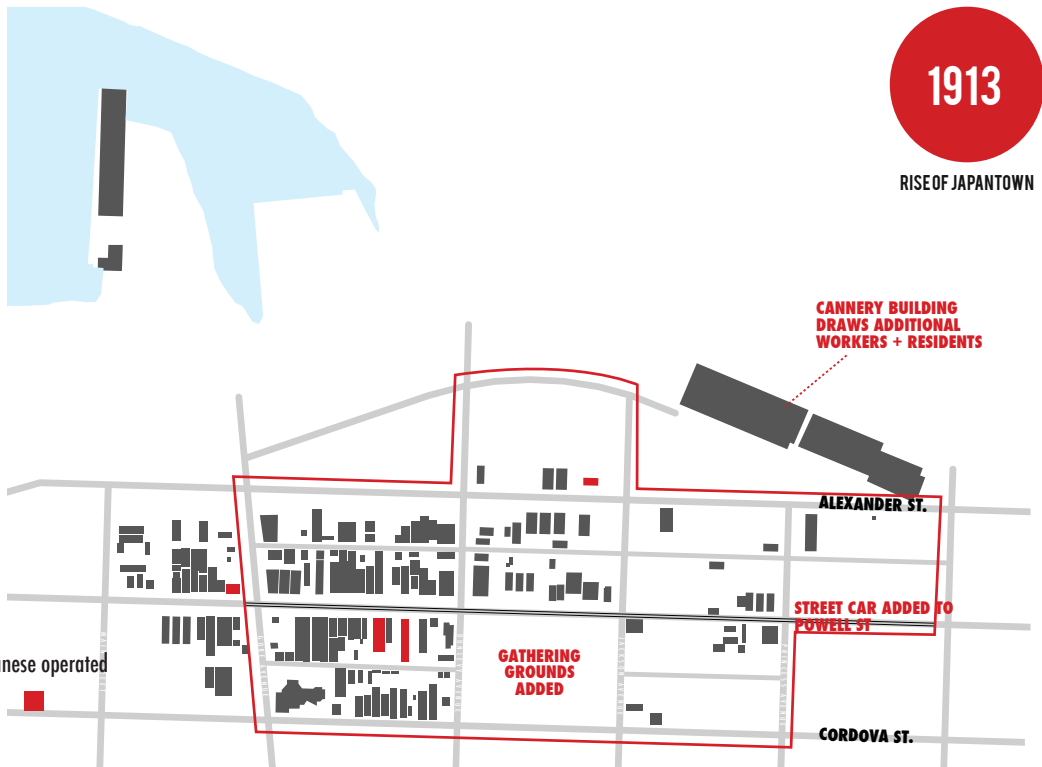

Japantown and Japanese population grows with addition of cannery



More than half of Japantown's property either owned or operated by Japanese-Canadians



Japantown converted into a light industrial zone in attempt to fill vacancies

Present Condition

In the last decade Japantown has shown signs of improvement, but still lacks the necessary diversity to foster a vibrant community. Design offices and light manufacturing have begun to populate the periphery, but crime, prostitution and drug-use remain as major problems in the service alleys and along the edges of Oppenheimer Park. The City of Vancouver's recent devotion to Single Resident Occupancy housing (SROs) has experienced mixed success and has resulted in a number of buildings being haphazardly converted from manufacturing to housing. SROs that incorporate services at street level have produced the most positive results, but unfortunately most properties in the area are not large enough or are too dilapidated to permit the inclusion of additional program.

Several internal planning reports have been conducted by the City of Vancouver on the Oppenheimer / Japantown area, with most recommending continued creation of SROs as the solution to a wide range of problems. However, an external report conducted by Birmingham and Wood produced recommendations in stark contrast to the city's official planning strategy. One of the report's primary recommendations was that property be provided to the Japanese community to expand cultural activities in the area, building upon the success of the annual Powell Street Cultural Festival. Birmingham and Wood's research and subsequent recommendation asserts that without the creation of cultural destinations and an increase in diversity, the Japantown area runs the risk of falling into further disrepair (Birmingham and Wood 2007, 79).

TRANSLATING EAST TO WEST

Central to this project is the translation and reinterpretation of Japanese culture to a western Canadian context, creating architectural spaces and urban strategies that are sensitive to the cultural roots of Japanese-Canadians and the urban fabric of the existing neighborhood. The Japanese-Canadian community that currently exists in Vancouver is markedly different than the *issei* and *nisei* generations that preceded them. In many cases the connection between these Japanese-Canadians and Japan is limited or non-existent. However, despite this lack of connection there is still a strong association with customs that are clearly closer in nature to Japanese than western Canadian customs (Birmingham and Wood 2007, 64). Most families with Japanese heritage still identify with notions of the group over the individual, observe important Japanese cultural festivals (Obon, Shogatsu and Hanami being the most pronounced) and still eat a “Japanese diet” consisting primarily of fish, grilled meats, vegetables and rice (Gumi 2011, 18).

While it is important to beware of the haphazard application of cultural icons, it is equally important to recognize that authenticity is more about the expression of an idea than a physical object. As food writer Todd Kliman explains,

The more I think about it, the more I think authenticity is nothing more than a matter of angle from which you choose to look. A purely arbitrary, purely subjective surmise of a purely impure thing ... (Kliman 2011, 83)

Though it is important to be careful and considerate when translating culture, it is equally important to allow natural evolution of practices and techniques to occur.



Powell Street Cultural Festival (from top): *taiko* drummers, grilled salmon, and carrying of the *mikoshi* shrine.

PROCESS AND RITUAL IN JAPANESE CULTURE

The rituals intrinsic in the production, processing and consumption of foodstuffs are a pronounced aspect of Japanese culture. From the highly ritualized tea ceremony to the efficient choreography required in *soba* making, Japanese food (and much of Japanese culture) is steeped in the rituals of transformation (Isozaki 2011, 141).

In food, art, industry and architecture the process of making has come to represent not just a learned technique, but also an approach towards life. Economy, moral geometry, respect for the past and appreciation of the present are all evident in the act of production. Kazuko Okakura's *The Book of Tea* explains how tea is the expression of a philosophy of life.

The philosophy of Tea is not mere aestheticism in the ordinary acceptance of the term, for it expresses conjointly with ethics and religion our whole point of view about man and nature. (Okakura 2009, 4)

Renowned Buddhist *roshi* Shunryu Suzuki echoes these sentiments, proclaiming, "preparing food is not just about yourself and others, it is about everything" (Chadwick 2001, 48). It is not uncommon for Japanese chefs to devote their entire lives to the mastery of a single dish, seeing each day as an opportunity to improve on their technique and obtain a better understanding of the subtlety of the ingredients, and in turn, a better understanding of themselves. Jiro Ono, considered by many to be the world's greatest sushi chef, has been making sushi for more than 67 years and still feels that he has not perfected his craft and that he likely never will (*Jiro Dreams of Sushi* 2011). This same dedication to quality and craft is easily recognizable in a number of Japanese industries, with knife making, carpentry, landscaping and

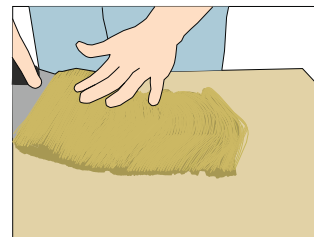
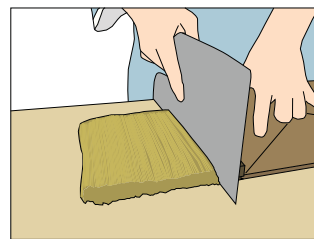
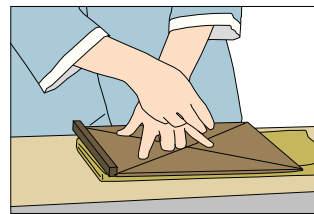
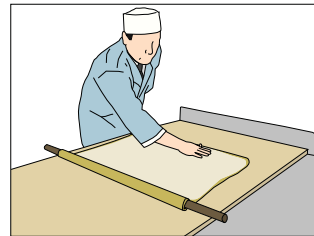
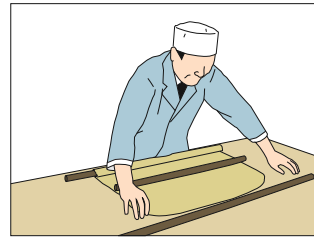
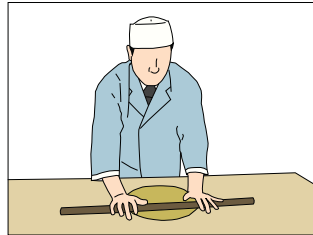
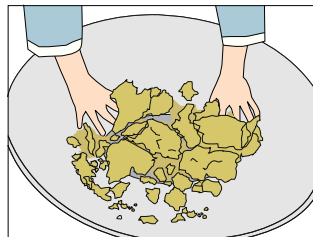
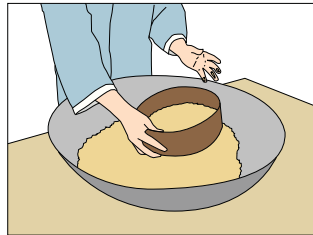
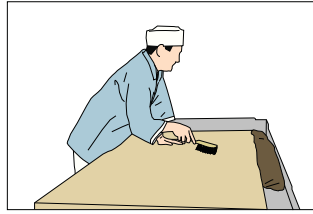

Traditional process of making *soba* noodles

tailoring being obvious examples.

One thing you need to understand about Japanese food culture is that you do one thing in any given type of cuisine, and that's all you do. If you try and do anything else you are just a poser. (Meehan 2011, 16)

The importance of process and ritual is not exclusive to the production, but is also integral to the consumption of Japanese food. “*Itadakimasu*” (I humbly receive) is chanted before commencing eating by nearly everyone in Japan, regardless of religious beliefs. This is a practice that has been maintained by most Japanese-Canadians and is representative of an approach to food that is very different from that of most North Americans. Eating mindfully is an important theme in Japanese food, a notion brilliantly depicted in Juzo Itami’s cult classic film *Tampopo*. In the film’s most memorable scene a wise master explains to a young enthusiast the proper way to eat *ramen*.

First observe the whole bowl. Appreciate its gestalt, savour the aromas. Jewels of fat glittering on the surface. *Shinachika* roots shining. Seaweed slowly sinking. Spring onions floating. Concentrate on the three pork slices. They play the key role, but stay modestly hidden. First caress the surface with the chopstick tips to express affection. Then poke the pork. Caress it with the chopstick tips. Gently pick it up and dip it into the soup on the right side of the bowl. What is important here is to apologize to the pork by saying “see you soon.” (*Tampopo* 1985)

In Japan, food is more than just sustenance, it is an obsession. As David Chang states, “In Japan, there is an obsession with food that goes far beyond any reasonable standards. One would expect that a *tonkatsu* sandwich from the convenience store would be inedible, but in Japan that sandwich will likely be better than any sandwich you could get in New York” (Meehan 2011, 5).

CHAPTER 2: DESIGN

SITE ANALYSIS

The present state of Vancouver’s Japantown is the result of a complex mix of social, infrastructural and planning problems. In order to properly address these serious concerns it is first necessary to understand where and why they are occurring.

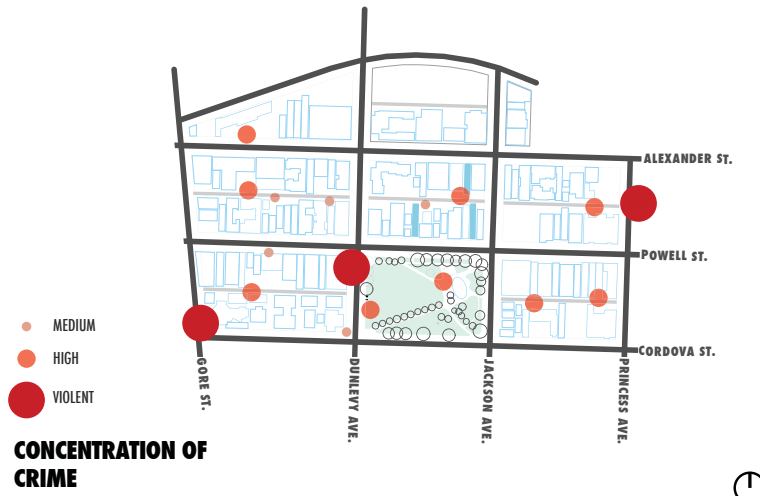

Crime, drugs and prostitution have spread from the DTES into Japantown, with concentrated pockets lining the alley and park.

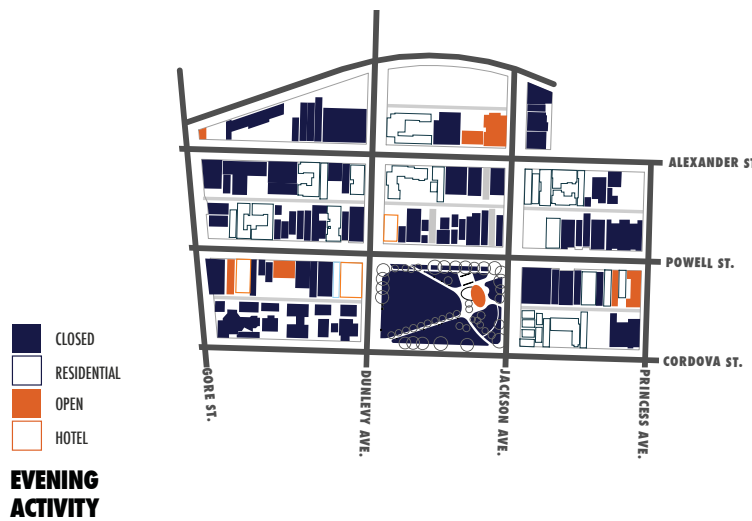

Very few businesses remain open after 6pm, leaving the streets vacant. With no evening destination there is little reason for locals to venture out, creating ideal conditions for illicit activities.





A high number of vacancies weakens the urban fabric, deters visitors, and leads to increases in crime.



High speed, one-way traffic during rush hour detracts from the pedestrian experience of Japantown. Instead of being a lively commercial hub it has become part of an expressway connecting East Vancouver with downtown.

The urban maladies illustrated in the diagrams above are interrelated, with each contributing to the exacerbation of the next. Crime can be seen as the result of a lack of an evening presence, which in turn leads to more vacancies and eventually more crime. The high-speed, rush-hour traffic created by the one-way streets of Powell and Cordova further aggravates this problem, as residents of the area opt for the pedestrian friendly streets of adjacent Gastown. This leads again to more vacancies and more crime.

The urban fabric of Japantown is also a significant obstacle in its revitalization. The deep, narrow lots that define the neighborhood are avoided by potential developers and have become ill-equipped, low-cost housing. This strategy, a directive of the City of Vancouver (City of Vancouver 2010), fails to address the needs of most of the residents of SROs, who require not just housing but also drug rehabilitation treatment and mental health services. A more integrated approach to treatment has been implemented successfully in the neighborhood and should be the focus of future planning initiatives. Converting former warehouses and manufacturing buildings into SROs also eliminates the potential of these small sites to become the catalyst for a meaningful change.



Entrances to two SROs in Japantown. Boarded windows, windowless facades and razor wire are common in this low quality housing.

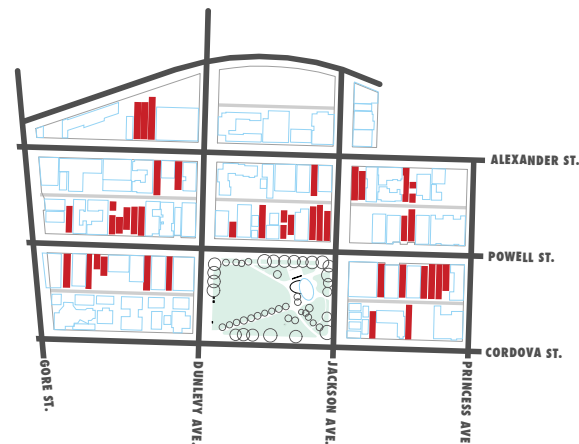

JAPANTOWN LOT



In addition to strengthening the existing urban fabric, a site strategy that focuses on the existing Japantown lots for initial and future phases of development ensures that larger sites remain available for the insertion of service-driven SROs and mid-rise housing. Both of these larger types of development are necessary in the revitalization of Japantown and planning for them will minimize disruption to the existing urban fabric.

The long, narrow lots that define Japantown are seen as a hindrance to its development, but offer significant potential to make a substantial change.



Existing large-scale developments and available lots for future development

It should be noted that the deep-seated social, cultural and economic issues that created the DTES are beyond the scope of this project and will require a revised strategy on drug-treatment services in the DTES and changes to the definition and requirements of SROs. This project seeks to mitigate these more complex problems, but remains focused on the revitalization of Japantown through increased urban vitality, site-sensitive architecture and re-establishment of cultural ties.

JAPANTOWN TYPOLOGY

Integral to the successful development of future phases of Japantown is the creation of an architectural typology. This typology is designed to take advantage of the long and narrow Japantown lots, connect to and strengthen the existing urban fabric and create a series of public spaces at various scales. The following diagram illustrates the steps taken in creating this typology, which will serve as the base for future architectural interventions in the neighborhood.

1

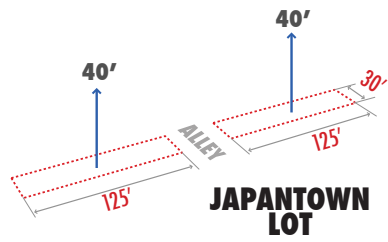

2

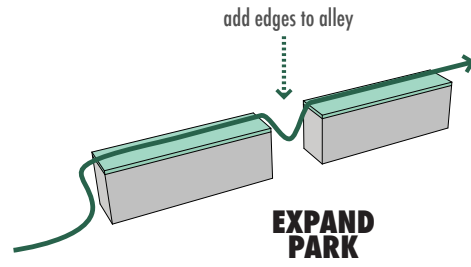

3

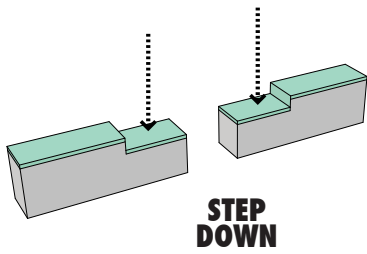

4

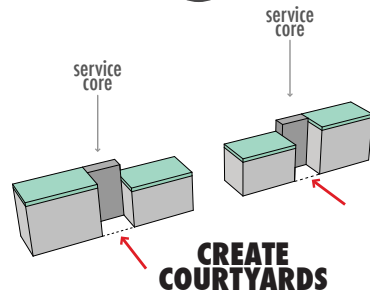

5

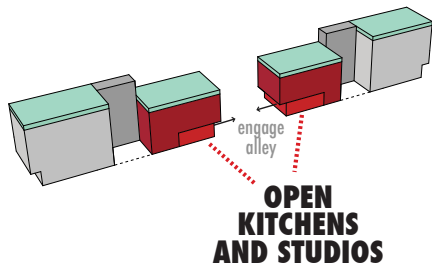

6

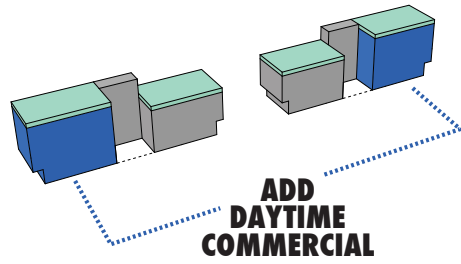

7

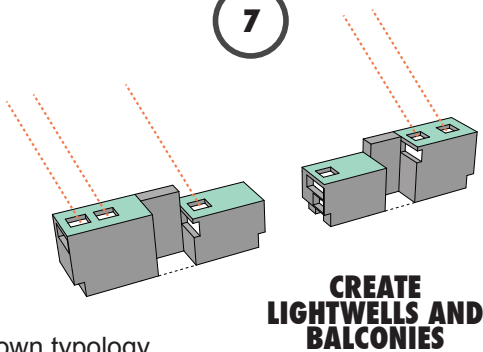

Development of the Japantown typology

SITE SELECTION

The initial phase of development focuses on the most historically significant block of the Japantown neighborhood. This initial proposal is intended to serve as the seed for future phases of development as revitalization spreads east and west of the Oppenheimer Park block.

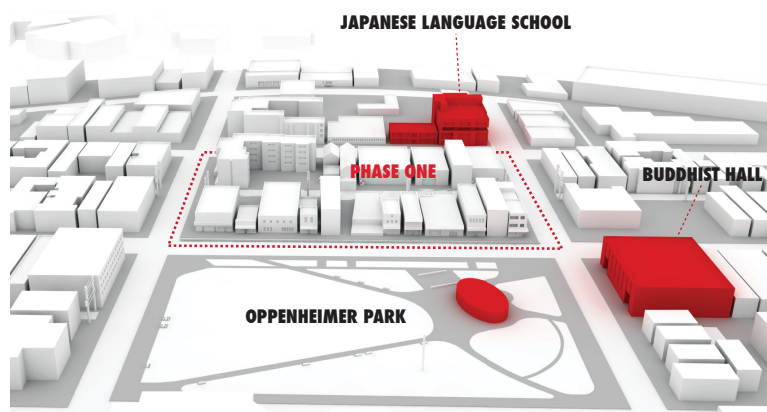

Extent of phase one development and culturally important adjacencies.

This historic block is also an important part of Japantown's current urban fabric, with the Japanese Buddhist Hall, Japanese Language School and Oppenheimer Park adjacent.

Within this block, three sites were chosen for further development. Site 1, located on the northeast side of the block, sits across from the Japanese language school on Alexander Street and helps to define the eastern end of the alley. Site 2 is located towards the southwest side of the block and creates a connection to Oppenheimer Park through a proposed breezeway that bisects the two former lots. Site 3 is located across the alley from Site 1 and creates a presence on the eastside of the block through a butcher shop on Powell Street and a ramen restaurant on the alley. (Site 3 has been developed to the programmatic stage, allowing for a more detailed exploration of the two sites.)

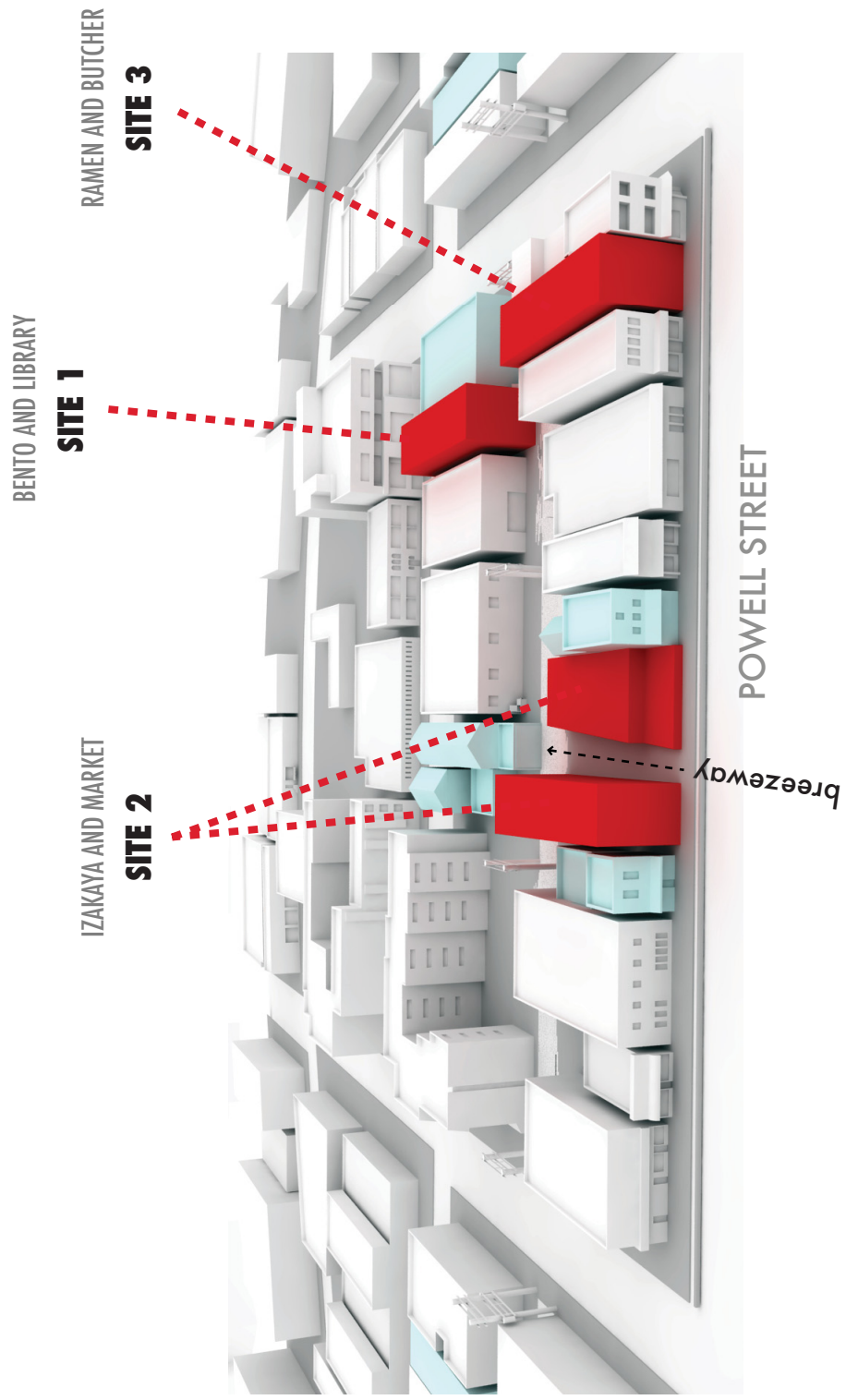

Site selection and accompanying programs

PROGRAM DEVELOPMENT

The development of the program for this thesis was conducted at two scales. At the urban scale a number of programs were chosen that simultaneously demonstrate a strong sense of craft while also offering elements of both modern and historical Japanese culture. As part of this program development a case study of Vancouver's adjacent Chinatown was undertaken to determine how it had been successful in the past and the factors contributing to its current decline (see Appendix). From this study it became clear that to make this revitalization of Japantown a socially, culturally and economically viable proposal it is necessary to insert programs that appeal to both local residents and Japanese-Canadians, making the area a part of everyday life, rather than a cultural novelty. A total of eleven programs were chosen to serve as seeds for future development. Some of these proposed programs have ancient cultural roots - carpentry, public baths, ceramics, knife-making and landscaping - while others represent a more modern devotion to craft - selvedge denim, steel bicycles and canvas bags. The following diagram illustrates the insertion points for the eight non-food-based programs.

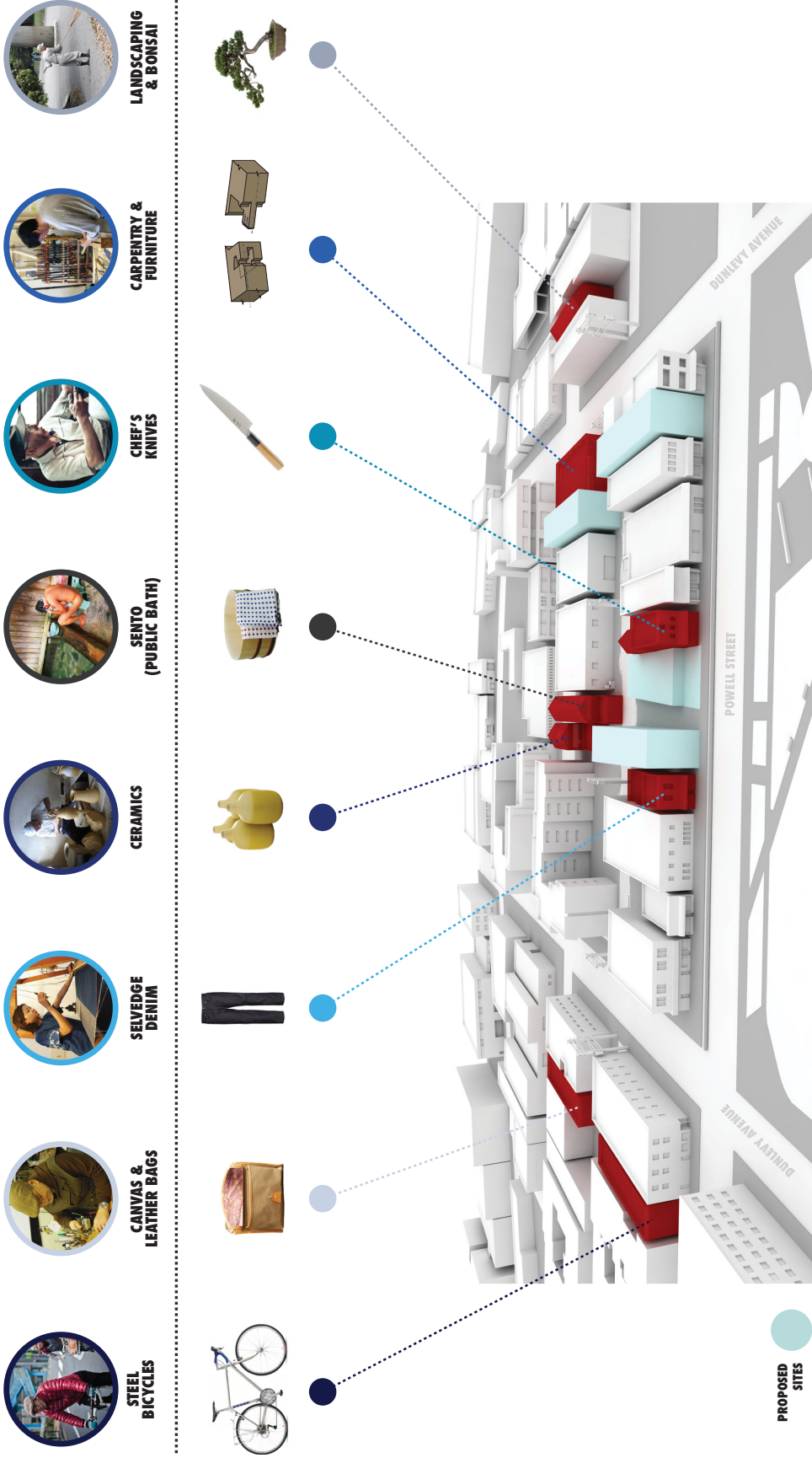

New programs for Vancouver's Japantown

Focusing on programs that display a strong sense of craft serves several purposes. First, and most importantly, it allows for patrons to experience and be part of the continuation of this cultural heritage. Second, it begins to establish a direction for future development and ties into the existing light manufacturing of the area. This showcasing of craft also offers a solution to one of the primary problems in the revitalization of Japantown: how to bring life to the derelict and dangerous alleyways? Capitalizing on the theatrical nature of production, the alleyways become the frontage for each building's workshops (or kitchens), while the street fronts provide access to commercial services and cultural centers.

The second scale of development focuses on revitalization of Japantown through individual buildings, focusing on the production and consumption of food. The importance of food to Japanese culture cannot be overstated, with its production and consumption representing an approach to life. In the same manner that the previous eight programs mixed modern and traditional, so do the proposed Japanese food programs.

In addition to being a cultural keystone, Japanese food is also one of the most widely enjoyed cultural cuisines in Vancouver. However, most of these purveyors are devoted to sushi, or an awkward interpretation of it. Contrary to popular belief, sushi is not commonly eaten in Japan due to its high cost in most prefectures. There are restaurants that offer lower quality sushi in Japan, but they are often looked down upon for their lack of dedication to quality and craft. This project seeks to introduce more mainstream components of Japanese food culture to residents of Japantown.

Bento boxes are common throughout Japan and range from the cheap and modestly-packaged convenience store variety to the handcrafted, multi-tiered, *shogatsu bento*. Filled with a variety of grilled meats, pickled vegetables, rice and other delicious foodstuffs, they are an integral and ubiquitous component of Japan's culinary landscape. The first of three food-driven programs combines a take-out *bento* kitchen with a Japanese food library. The *bento* kitchen is seen as a performative space that attracts and inspires, while the library offers an opportunity to delve deeper into the field of Japanese cooking. The library also provides a defined space where previous generations of Japanese-Canadians can record their own culinary history, to be shared with future generations.

Izakaya and *yakiniku* are difficult to resist when traversing any Japanese city in the evening. The smell of charcoal, fresh vegetables and grilling meat is known to produce a dream-like state in those unaccustomed to the sheer pleasure of its aroma. *Izakaya* are intimate eating establishments that specialize in a small number of dishes that highlight fresh ingredients and regional specialties. Much like a world-class sushi restaurant, a reputable *izakaya* is defined by the quality of ingredients and attention to simple, yet elegant preparation. The second food program combines an *izakaya* and *yakiniku* restaurant with a small market. Once again, the two programs are seen as being complementary, with the market providing fresh ingredients for the *izakaya*, and the *izakaya* highlighting the seasonal specialties of the market.



From top: restaurant *bento* with *sashimi* and *tempura*; *depa-chika bento* with *tonkatsu*, lotus root and rice.



From top: chicken skin and offal grilled by chef at *izakaya*; various beef cuts grilled at *yakiniku* (self-grilling restaurant)



ALEXANDER STREET

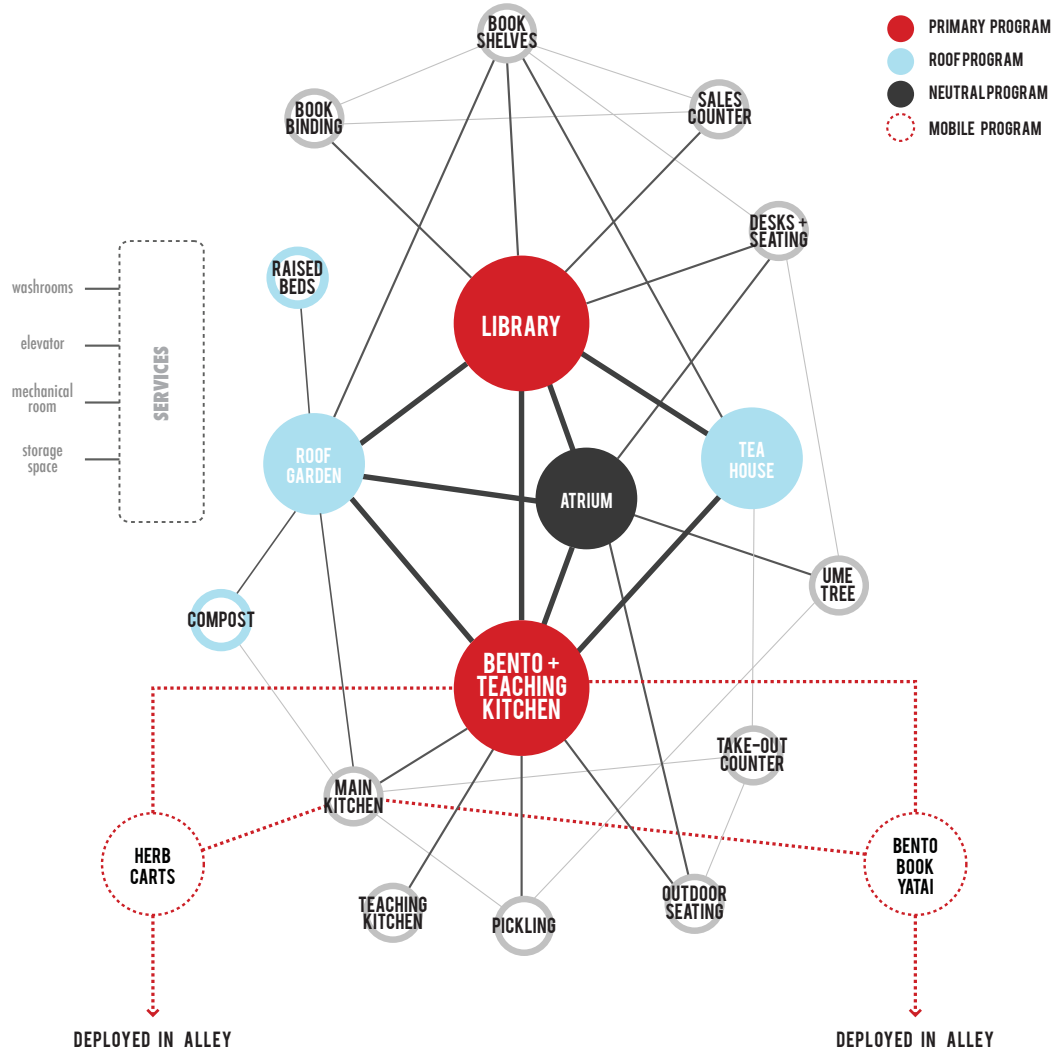

ALLEY



Bento kitchen and library program diagram



ALLEY

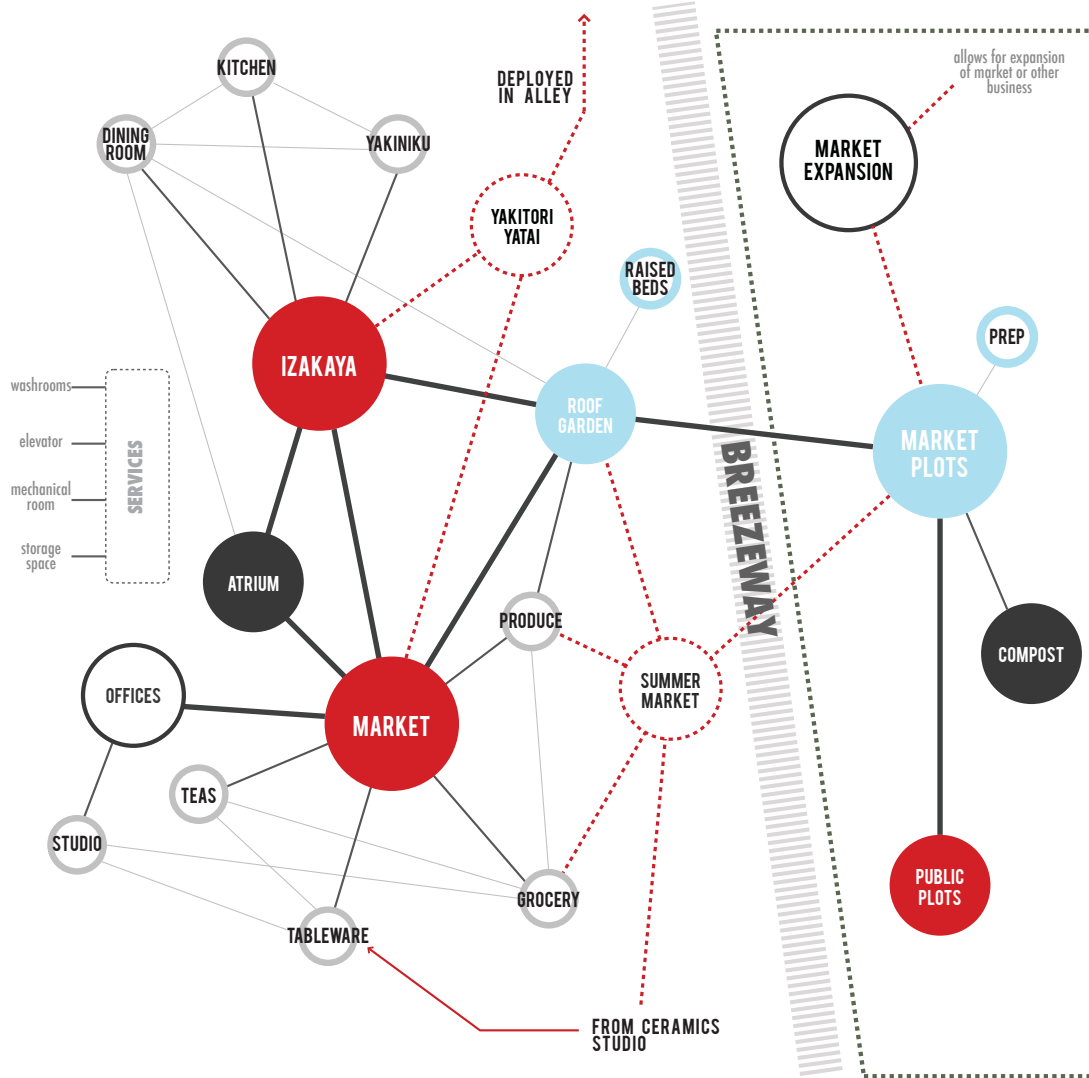

POWELL STREET



Izakaya and market program diagram



ALLEY

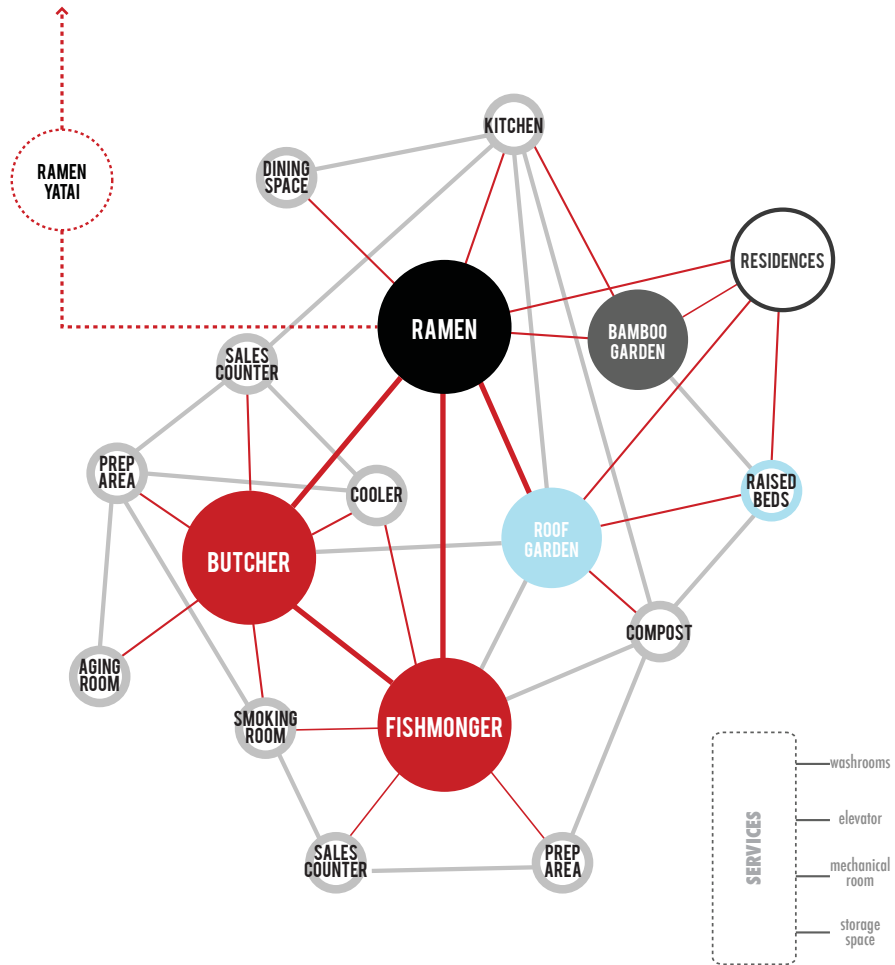

POWELL ST



Ramen and butcher shop developed to programmatic stage

USER GROUPS

The primary users of these facilities are the residents of Japantown and its adjacent neighborhoods. The Japanese-Canadian community is integral to the development and maintenance of this project, but the services offered in this phase and proposed future phases were conceived with both local residents and Japanese-Canadians in mind. This approach is akin to the Powell Street Japanese Cultural Festival, which encourages members of all ethnic backgrounds and age groups to enjoy and participate in Japanese culture. Those who work and live in Japantown presently are forced to venture to Gastown, Chinatown or the East Van neighborhoods to enjoy a delicious dinner, buy groceries or sit in a comfortable setting and relax. This intervention endeavors to provide the necessary amenities to satisfy local residents, while also drawing residents from the surrounding neighborhoods. The following two drawings illustrate the diversity of local residents and the generational difference amongst Japanese-Canadians.

Historic Gastown is a popular tourist destination and home to a large number of design studios, boutique retail stores and small galleries. A strong food movement currently exists in the area and places emphasis on quality, variety and atmosphere.

Chinatown is home to older Chinese residents who continue to own and operate buildings in the area. New developments are adding density and are threatening to further erode this ethnic enclave.

The Japantown / Railway district is filled with design offices that often venture out for lunch in Gastown (due to lack of options in the area)

The West End is home to a number of Japanese ESL schools and is the current hub for Japanese food.

Yaletown is defined by a young and affluent population seeking familiar cultural products.

Mount Pleasant, a neighborhood defined by its artist population, is a short skytrain or bicycle ride away from Japantown.

Strathcona is home to a large number of artists and individuals employed in artistic fields. There is a growing number of young families moving into the area, leading to further diversification.

East Van, the former home to working class immigrants, remains a highly diverse area, although rapidly increasing property value is changing the area's make-up

COMMERCIAL
MIXED USE
RESIDENTIAL
SEMI-URBAN
JAPANESE HUB

STANLEY PARK

WEST END

GASTOWN

JAPTOWN

STRATHCONA

VALETOWN

EAST VANCOUVER

MOUNT PLEASANT

Residents of adjacent neighborhoods

NISEI



DAYTIME + EARLY EVENING
TRADITIONAL FOODS + CULTURE
ACCESSIBILITY CONCERNS

SANSEI



AFTER WORK + DINNER
TRADITIONAL + MODERN JAPANESE FOODS
BRING CHILDREN

YONSEI



LUNCH, DINNER + LATER
EAGER TO LEARN ABOUT JAPANESE FOOD
CASUAL ATMOSPHERE

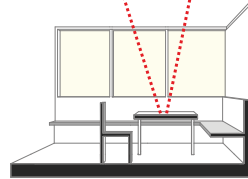
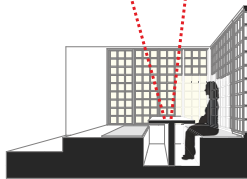
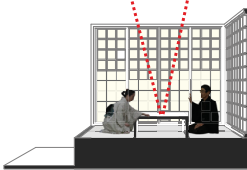

TRADITIONAL DINING

SEMI-TRADITIONAL DINING

MODERN DINING



primarily male
labor intensive
strong spiritual + cultural significance



kashiwa mochi



male + female
more ingredients
food still cultural but less spiritual



okonomiyaki



trained in eastern + western techniques
male + female
appeal to larger demographic



green curry ramen

Generational differences amongst Japanese-Canadians

BENTO KITCHEN AND LIBRARY (SITE 1)

Using the defined Japantown typology as a guide for its initial layout, the *bento* kitchen was situated along the alley and the library was placed across from and in dialogue with the Japanese Language Hall on Alexander Street. The two programs wrap around an open-air central court that is defined by an *ume* tree. The tree is both a symbolic reference to *umeboshi* (a mainstay of *bento* boxes) and an important part of *hanami* (as *ume* blossoms flower and fall in the same manner as *sakura*). The courtyard also functions as an important public space within the building where *bento* boxes, books and all types of Vancouverites come together.

The *bento* kitchen and library uses the organization of a new year's *bento* (*osechi no ryori*) to inform the vertical organization of the programme in the building. New year's *bentos* are organized by the intended order of consumption, with the freshest ingredients on the top and more preserved foods on the bottom. This same idea has been applied to the building, with the more easily accessible programmatic spaces located on the ground floor (magazines and periodicals on the library side and take-out *bento* on the *bento* kitchen side) and more involved programmatic spaces on the upper levels (private cooking classes on the *bento* side and Japanese cooking texts on the library side). This allows users to make a meal of the building, beginning with familiar and easily consumable morsels and eventually progressing to the more complex and unknown.

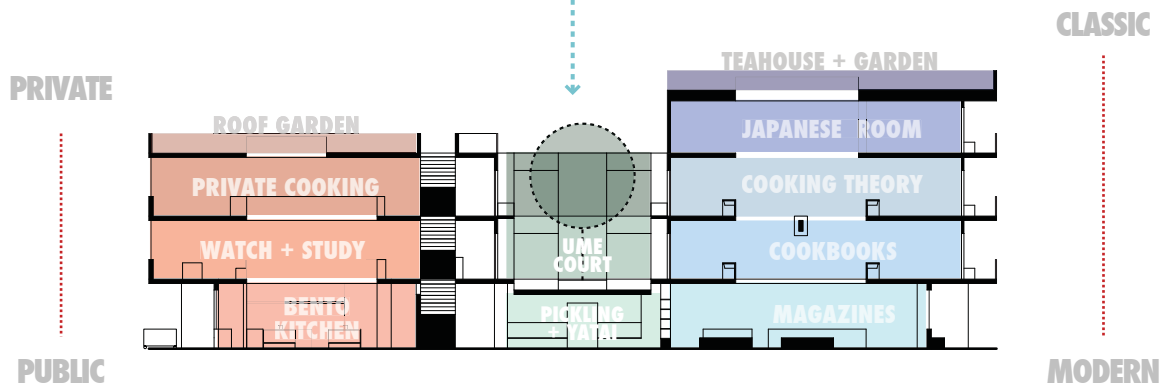
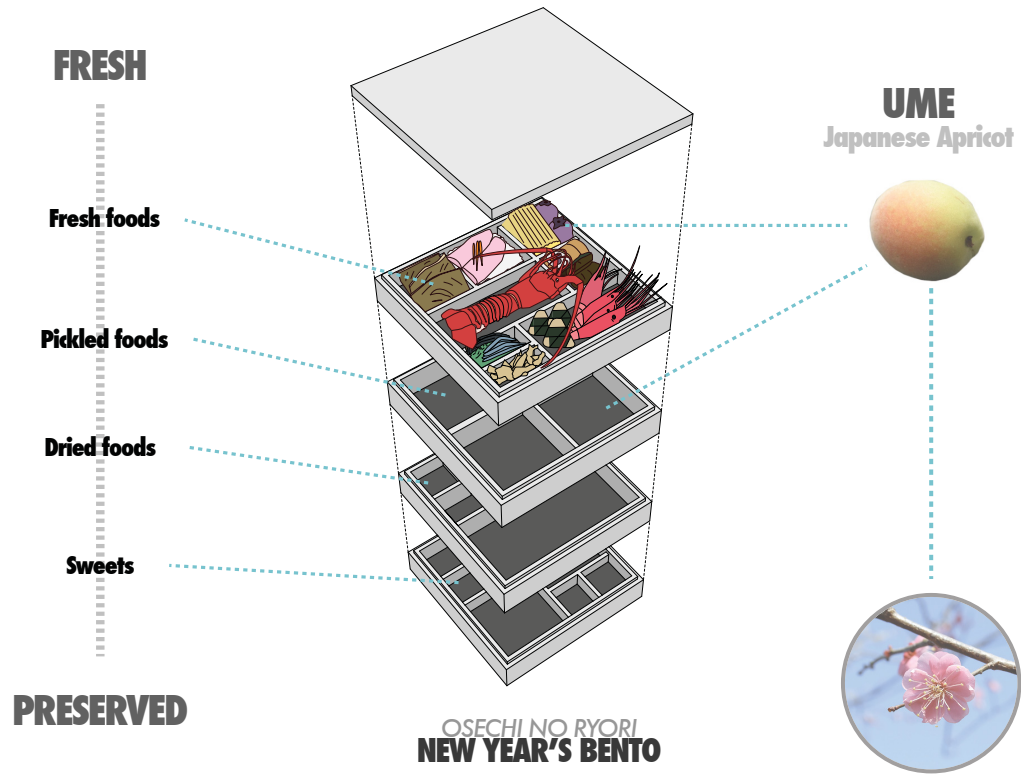

Bento organization and its influence on programmatic layout

The building is considered to have two frontages, with each receiving a specific treatment. On the alley side generous views are offered into the *bento* kitchen, allowing residents to see, smell and hear the act of production. The kitchen also features a pair of mobile herb carts that can be wheeled into the alley or transformed into outdoor workspace. A *yatai*, parked in the middle of the building, serves as another theatrical component, ceremoniously exiting the building to offer library books and *bento*-boxes throughout Japantown.

The present state of Japantown necessitates a certain level of security screening on the alley frontage. This has been addressed with a sliding wooden screen, softening the message created by typical steel security screens, while still offering a reasonable level of protection.

The street frontage has been treated in very different manner than the alley. The library is designed to blend in with the rest of the block at street level with an unassuming entrance. However, upon entering visitors are welcomed by a light-filled atrium defined by compartmentalized shelving. The upper levels of the library offer various levels of intimacy and create a strong connection between the Japanese language school and this newly created library. Bookshelves are used to draw visitors through the building, with bookstacks integrating the program of the *bento* kitchen and the library.

The stepped roof is used to grow vegetables for the *bento* kitchen and offers another place for learning (and reading). A greenhouse for growing tea is situated on the south side of the roof, while a simple tea house on the north end offers views of the North Shore mountains.

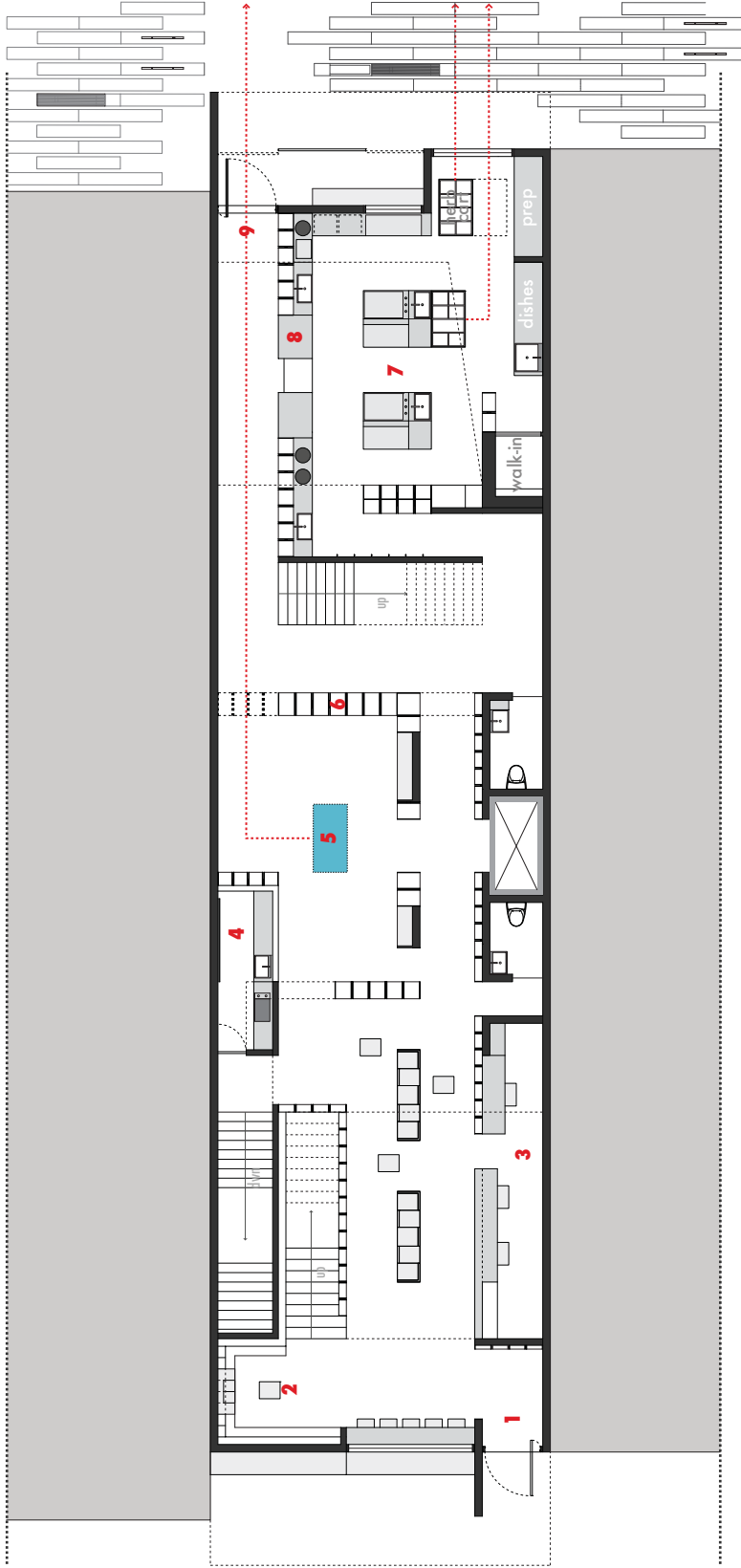

1:200

- 1 Alexander Street entrance
- 2 Magazine display
- 3 Service desk
- 4 Pickling kitchen
- 5 *Yatai*
- 6 Pickle storage
- 7 Bento kitchen
- 8 Take-out counter
- 9 Alley entrance

Ground floor plan with herb carts and *yatai* moving into alley

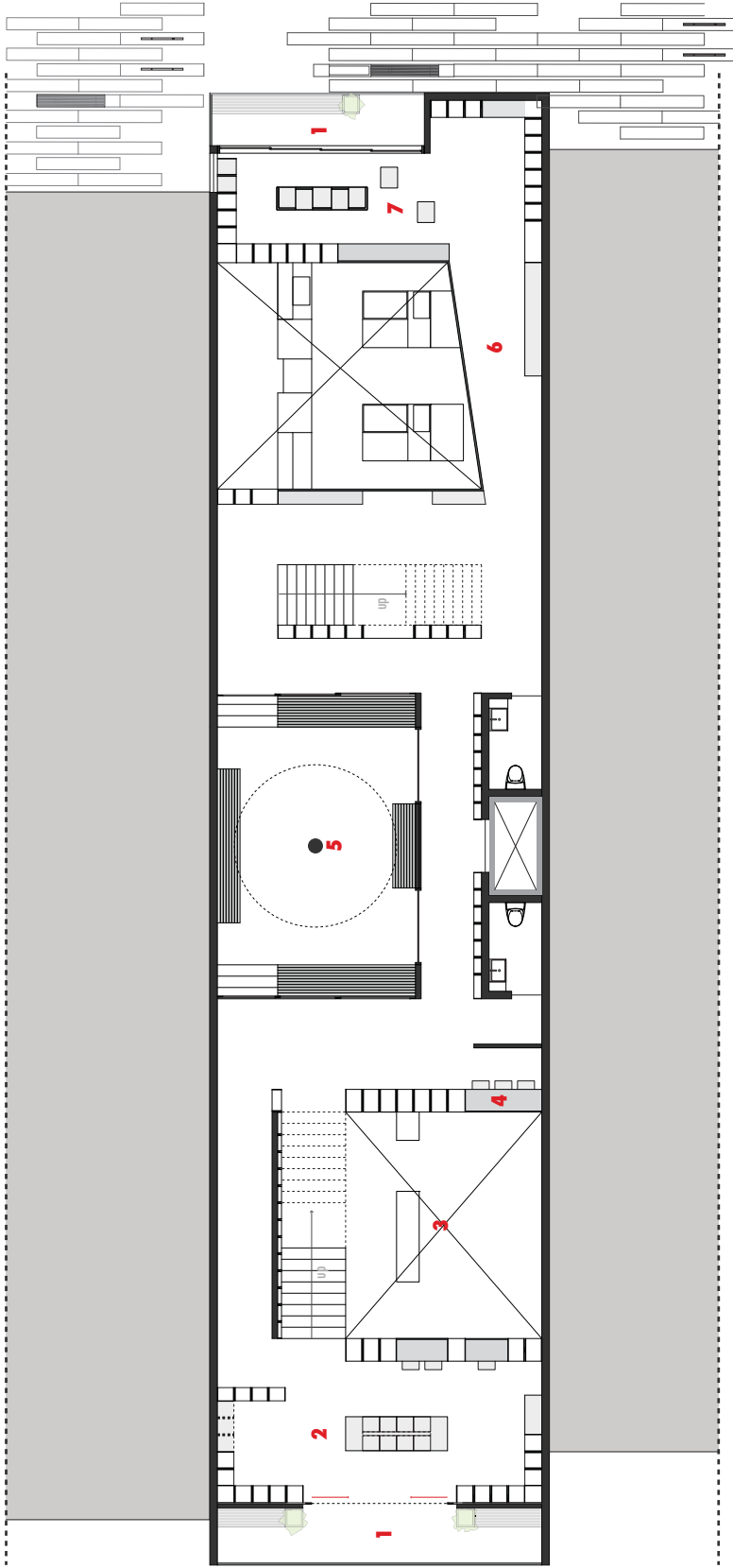

1:200

- 1 Covered balcony
- 2 Cookbooks
- 3 Open to below
- 4 Study carrel
- 5 Ume court
- 6 Viewing gallery
- 7 Bento cookbooks

Second floor plan with *ume* courtyard in center

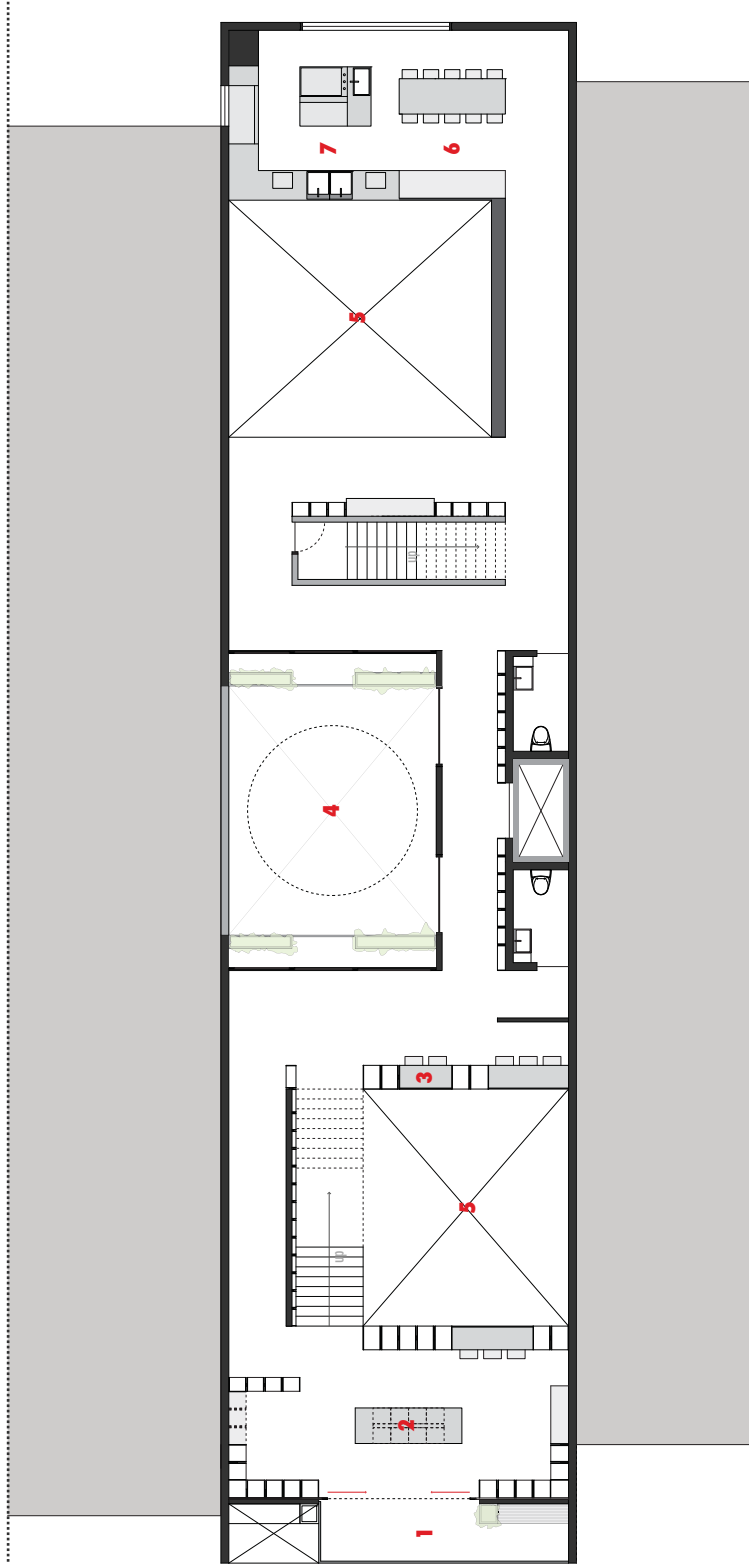

1:200

- 1 Covered balcony
- 2 Cooking texts
- 3 Study carrel
- 4 Ume court
- 5 Open to below
- 6 Dining area
- 7 Small teaching kitchen

Third floor plan with private teaching kitchen on alley side

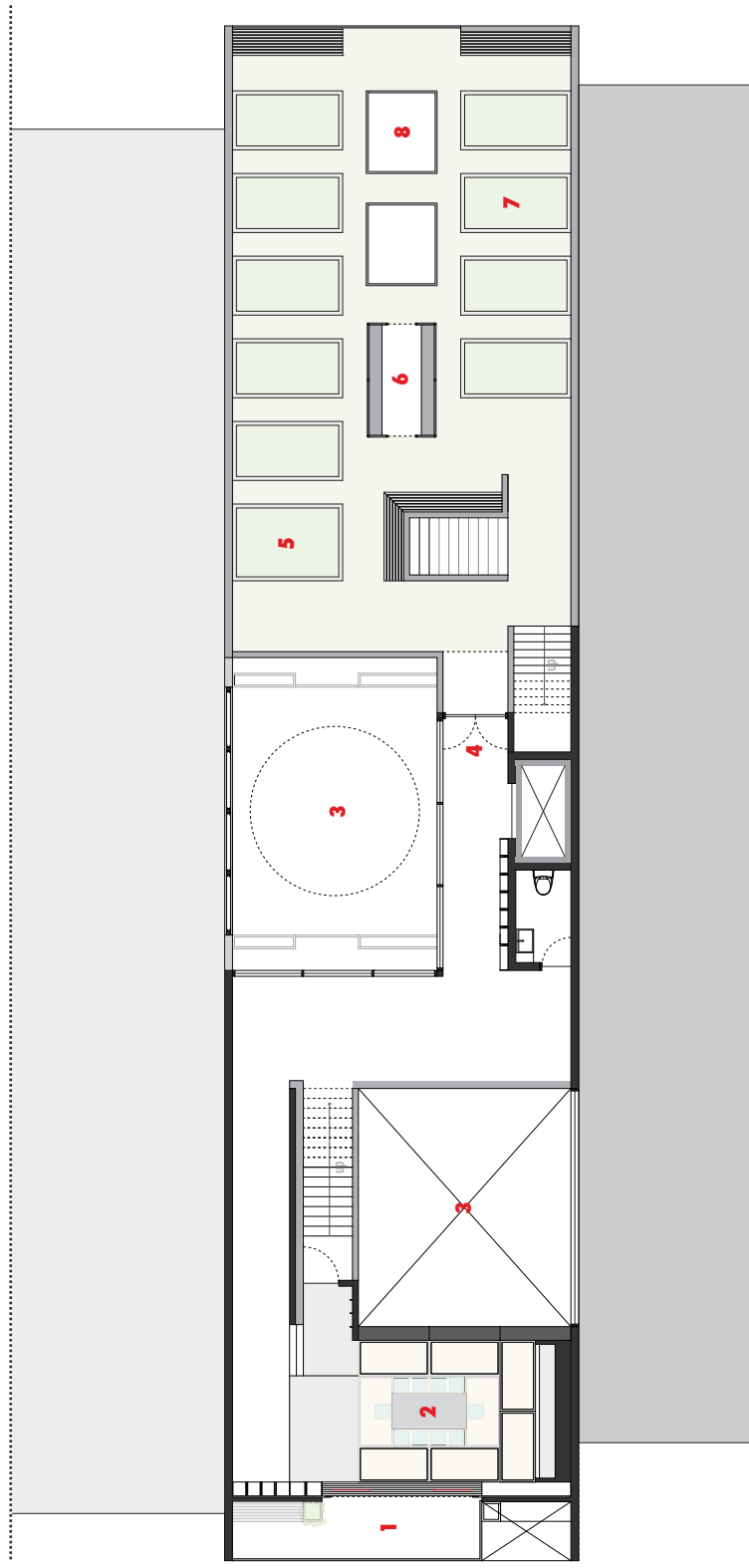

1:200

- 1 Covered balcony
- 2 Japanese room
- 3 Ume court
- 4 Open to below
- 5 Compost
- 6 Tea greenhouse
- 7 Planting beds
- 8 Lightwells

Fourth floor plan with roof garden on alley side and Japanese room on Alexander Street

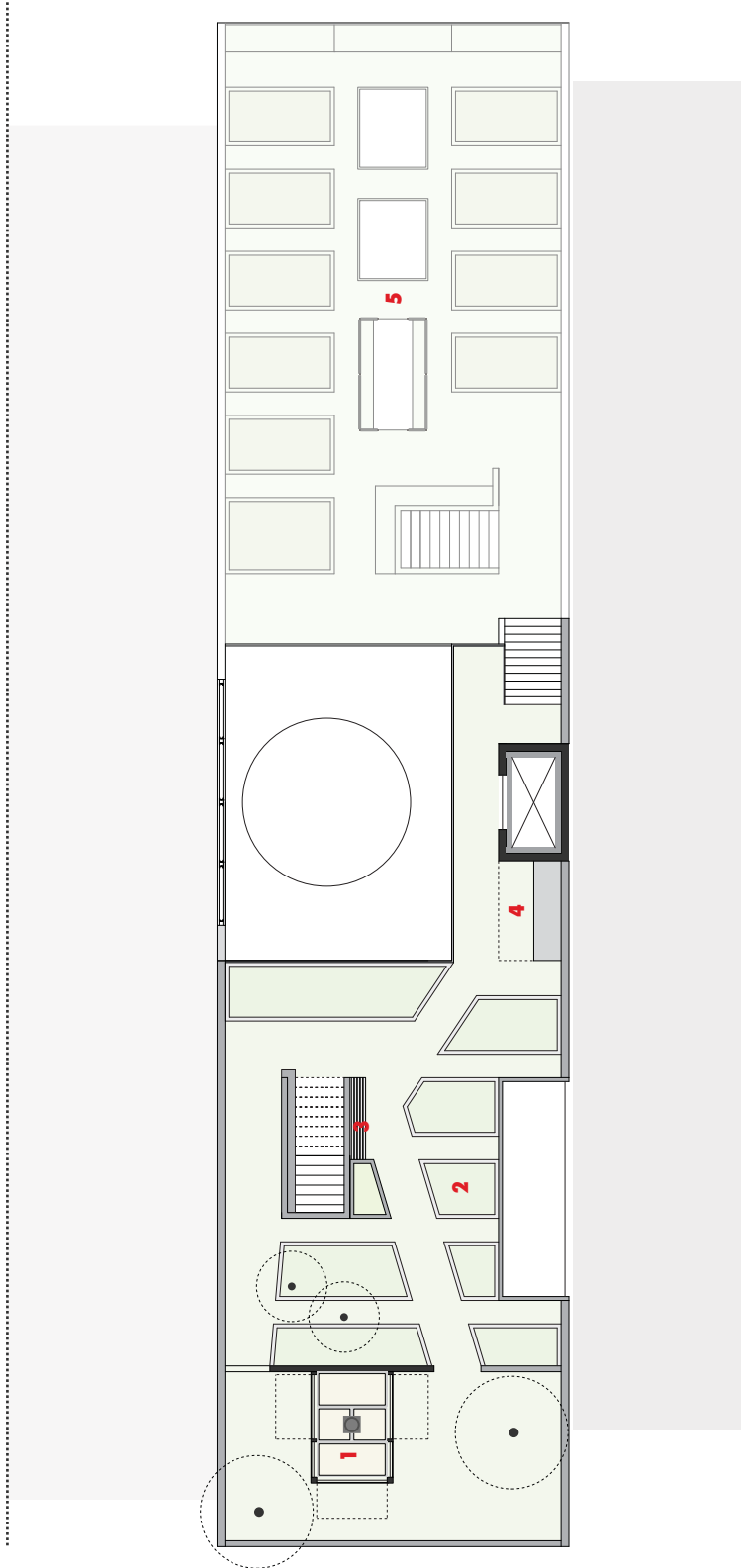

1:200

- 1 Tea house
- 2 Planting beds
- 3 Waiting area
- 4 Work tables
- 5 Garden below

Roof plan with tea house looking towards North Shore mountains

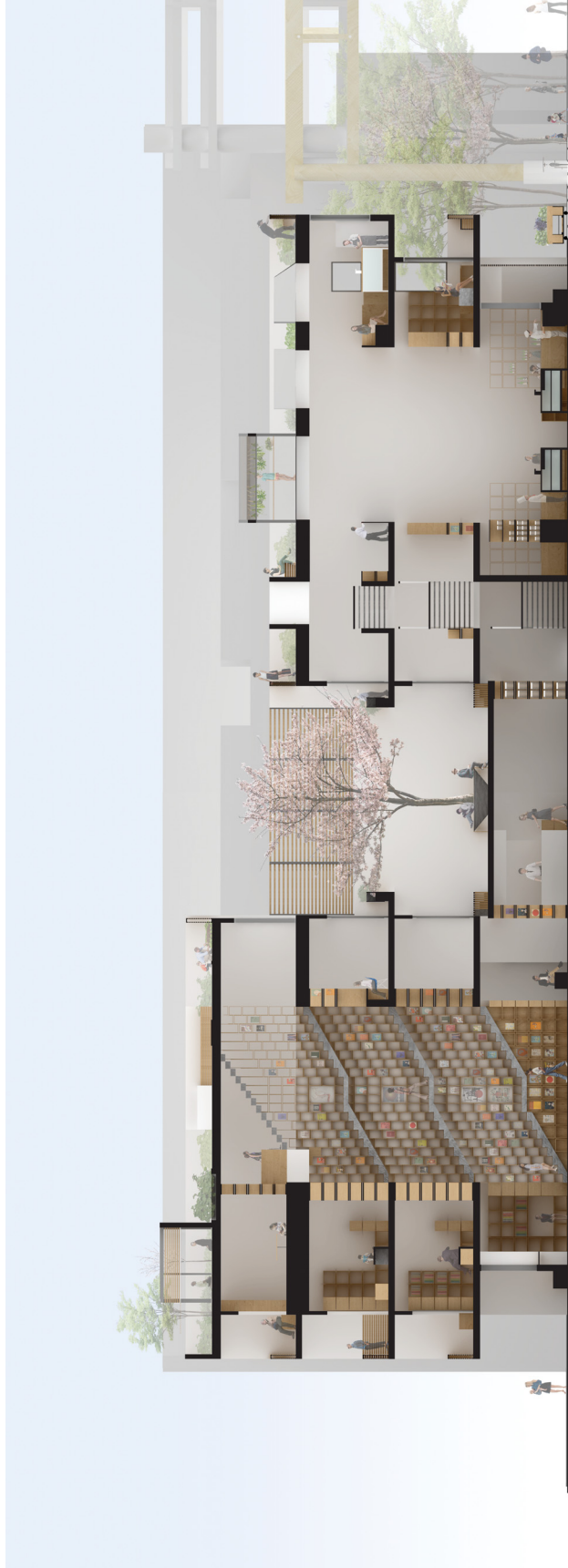

ALEXANDER
STREET

ALLEY

Longitudinal section looking east



Alexander Street (library) entrance



View of second level reading room



Cross section through *ume* courtyard looking north



Bento kitchen and mezzanine viewing gallery above



View through pickling kitchen with integrated bookshelves

IZAKAYA AND MARKET (SITE 2)

Beginning with the previously defined Japantown typology, the market was placed on Powell Street and the *izakaya* on the alley. This orientation is intended to emphasize Powell Street's role as the commercial street and the alley as a place of theatrical production. As a means of connecting the alley with Oppenheimer Park, a breezeway was created between the two existing sites and lined with cherry trees. In addition to creating a strong visual connection between the re-designed alley and the park, the breezeway creates an ideal space for a seasonal market and expands the existing festival space. The courtyard that connects the market and the *izakaya* is defined by an autumn flowering cherry tree that offers an interesting contrast to the spring flowering cherries of the breezeway and park. The courtyard also houses elements of both the *izakaya* and the market, with mobile produce carts and *izakaya* counter seating expanding into the space at different times of day. Vegetable gardens on the roofs of the buildings provide growing space for speciality crops and offer an area for community gathering and learning.

The architectural ingredients of the *izakaya* and market were treated in a manner analogous to the ingredients in *yakitori*, a mainstay of *izakaya*. This was not intended to be a direct translation between cooking chicken and architectural materials, but rather an effort to highlight tenets integral to both processes. Consideration has also been given to the difference between raw and cooked ingredients and their accompanying material palettes.

MATERIALS

'C' channels tied at sides + top

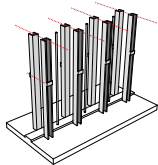

form ties threaded through boards

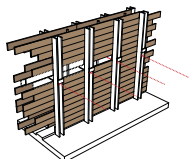

board forms attached through 'C' channels

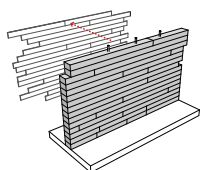

boards leave grain impression

cedar forms cleaned



boards wired together in threes and paper is lit at the base, creating a large chimney

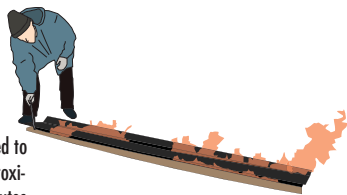

boards allowed to burn for approximately 7 minutes



water stops charring process - boards allowed to dry and harden before installing

INGREDIENTS



TAIL

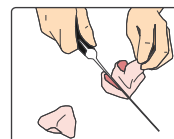

cut around bone

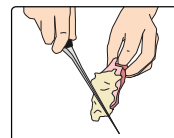

cut around sphincter and discard



remove and discard fat below hips

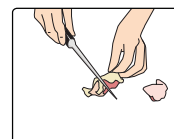

cut around the bone leaving all fat

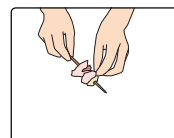

skewer meat, skin, fat, meat

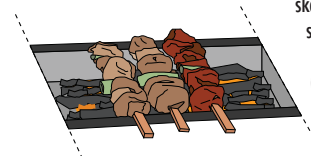

skewers grilled for a short period over white hot coals (up to 1,000 C)



skewers dipped in tare (a reduced soy mixture) prior to serving

BEGIN WITH HIGH QUALITY

IMPORTANCE OF PREP

PROCESS EVIDENT

CHARRING PROCESS

SIMPLY TREATED

Analogous treatment of architectural and edible ingredients

The market is defined by an atrium that connects all four floors, offering views into prep spaces and the offices above. The retail space is situated primarily on the ground level, but also extends to the second floor where customers can sit at a tea bar that overlooks both the market and Oppenheimer Park. Access to the offices and a small packaging design studio that occupy the upper floors can be controlled through both the internal stairs and courtyard access, allowing these spaces to function independently from the market.

The additional frontage afforded by the breezeway allows the market to spill into the newly created pedestrian pathway, while a series of foldable slatted screens provide protection from the elements. These slatted screens also provide additional security for the building during the evening.

The *izakaya* is spread over three floors, with each floor offering a slightly different dining experience. The ground floor is a traditional *izakaya*, defined by an open grill station and counter seating. The second floor combines a mix of counter seating and private booths where customers can grill their own food on a small table grill (*yakiniku*). The third floor offers a small amount of indoor seating, but its primary function is to allow customers to eat outdoors with views of the alley, the breezeway and the roof gardens of the adjacent building.

The building located on the east side of the breezeway has been proposed as a possible space for the expansion of the market, but could be tailored to suit a variety of programs, depending on the evolving needs of the area. This building's primary function for this initial phase is to provide additional growing space for both the market and community garden.

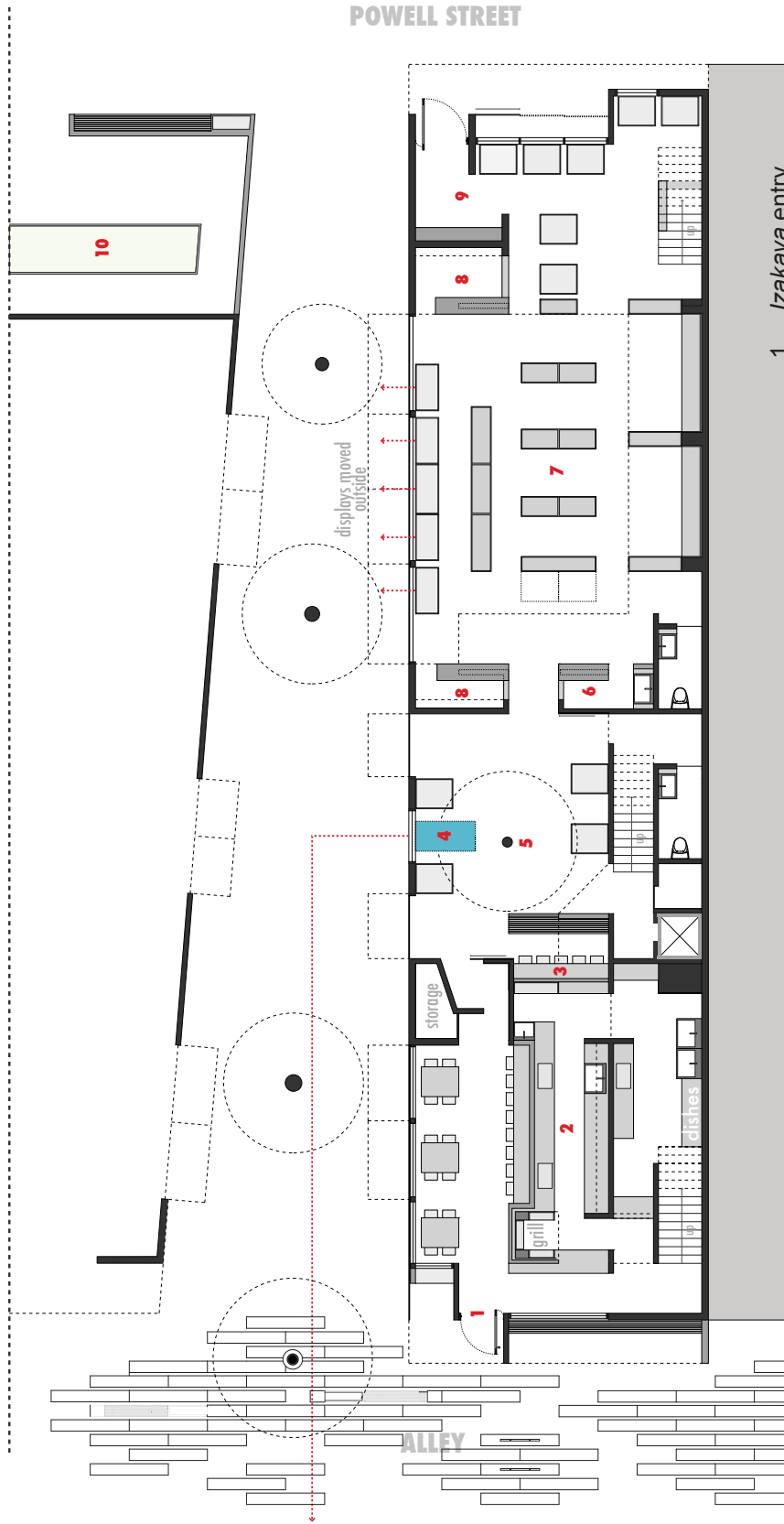

- 1 Izakaya entry
- 2 Open kitchen
- 3 Courtyard seating
- 4 Yakitori yatai
- 5 Courtyard
- 6 Vegetable prep space
- 7 Market
- 8 Checkout
- 9 Powell Street entry
- 10 Community garden

1:200



Ground floor - izakaya and market

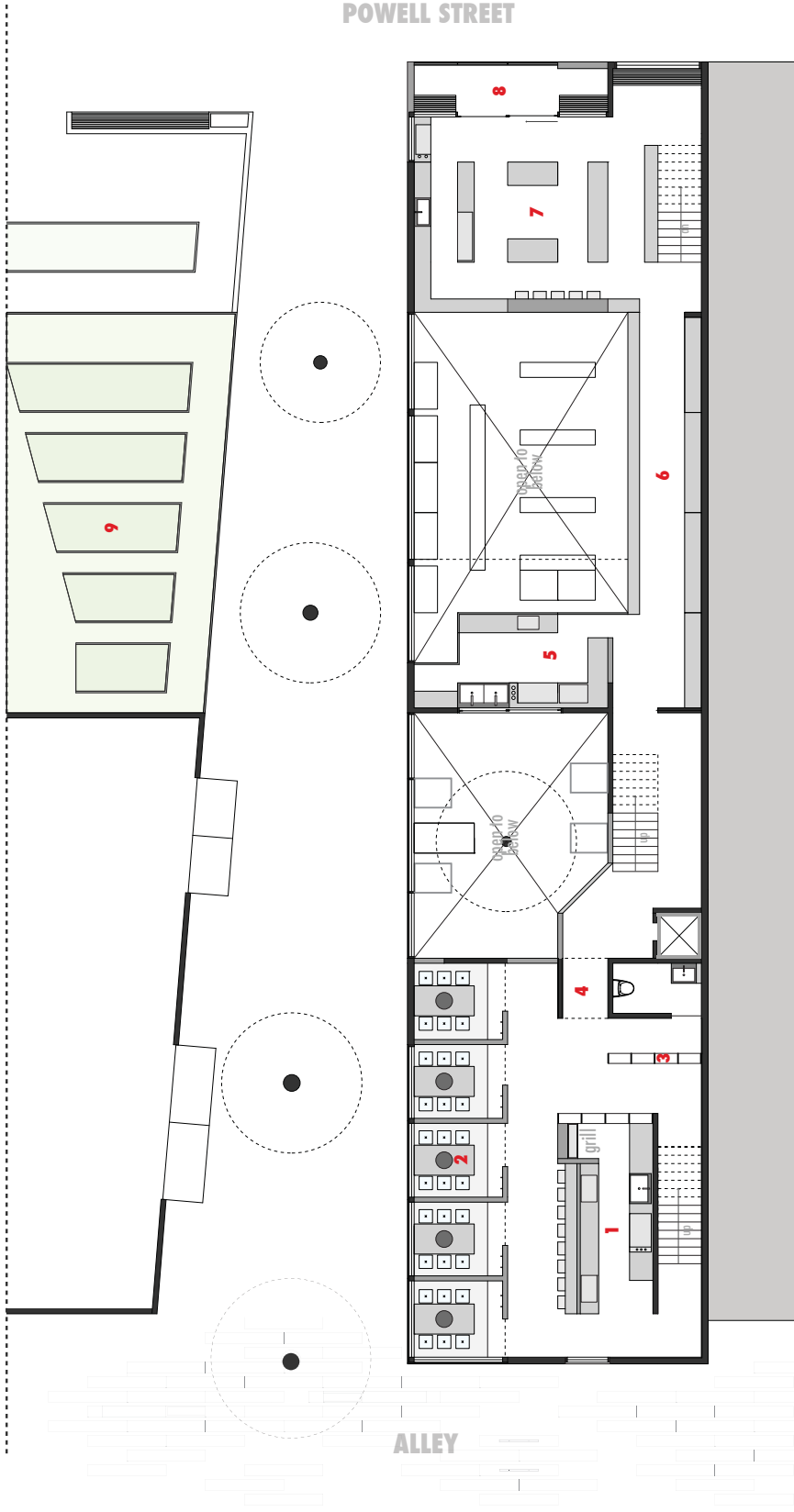

- 1 Open kitchen
- 2 Yakiniku booths
- 3 Charcoal storage
- 4 Yakiniku entry
- 5 Prepared foods kitchen
- 6 Prepared foods
- 7 Tea bar
- 8 Covered balcony
- 9 Vegetable garden

1:200



Second floor plan - yakiniku and tea bar

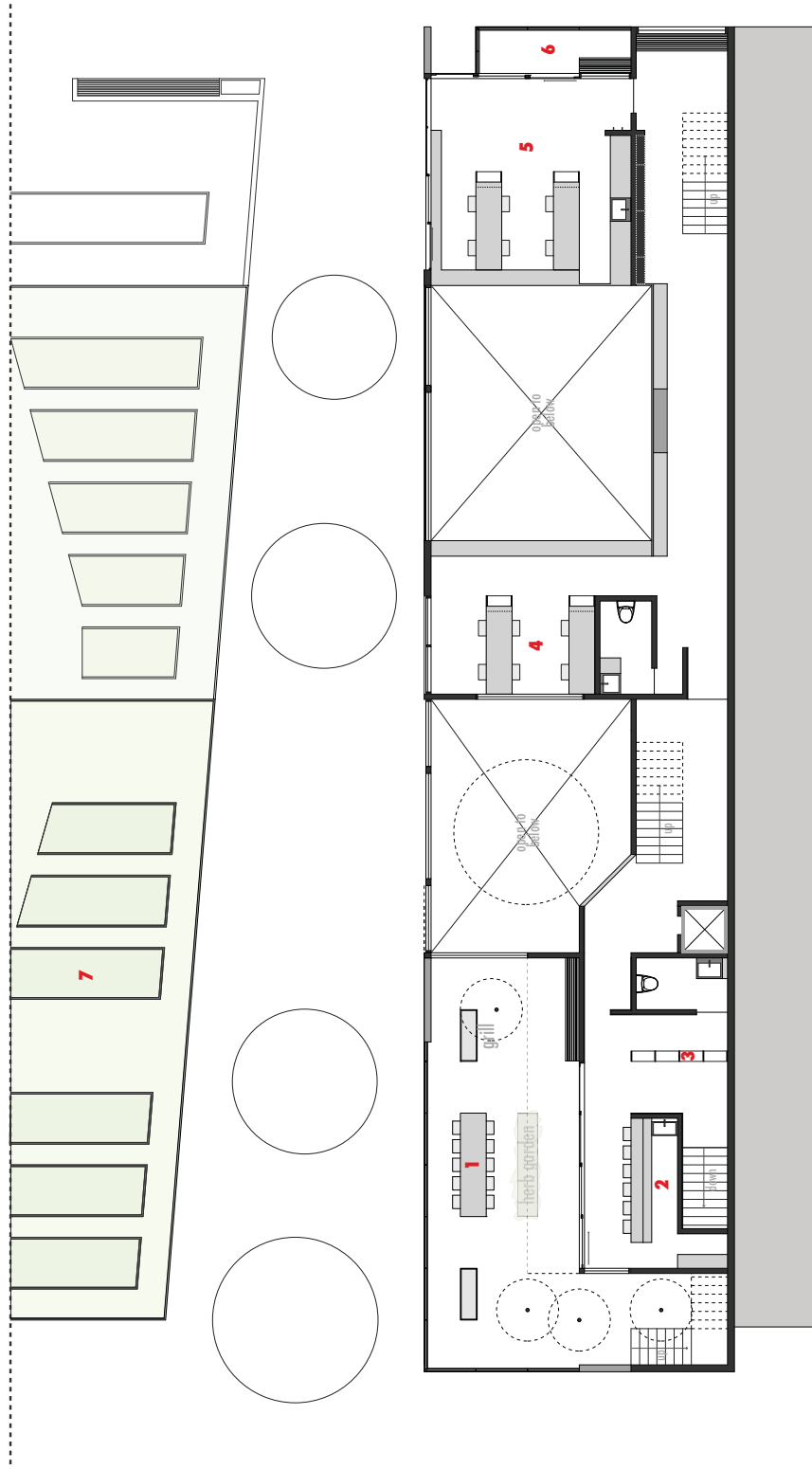

- 1 Outdoor dining
- 2 Roof bar
- 3 Charcoal storage
- 4 Office
- 5 Staff room
- 6 Covered balcony
- 7 Vegetable gardens

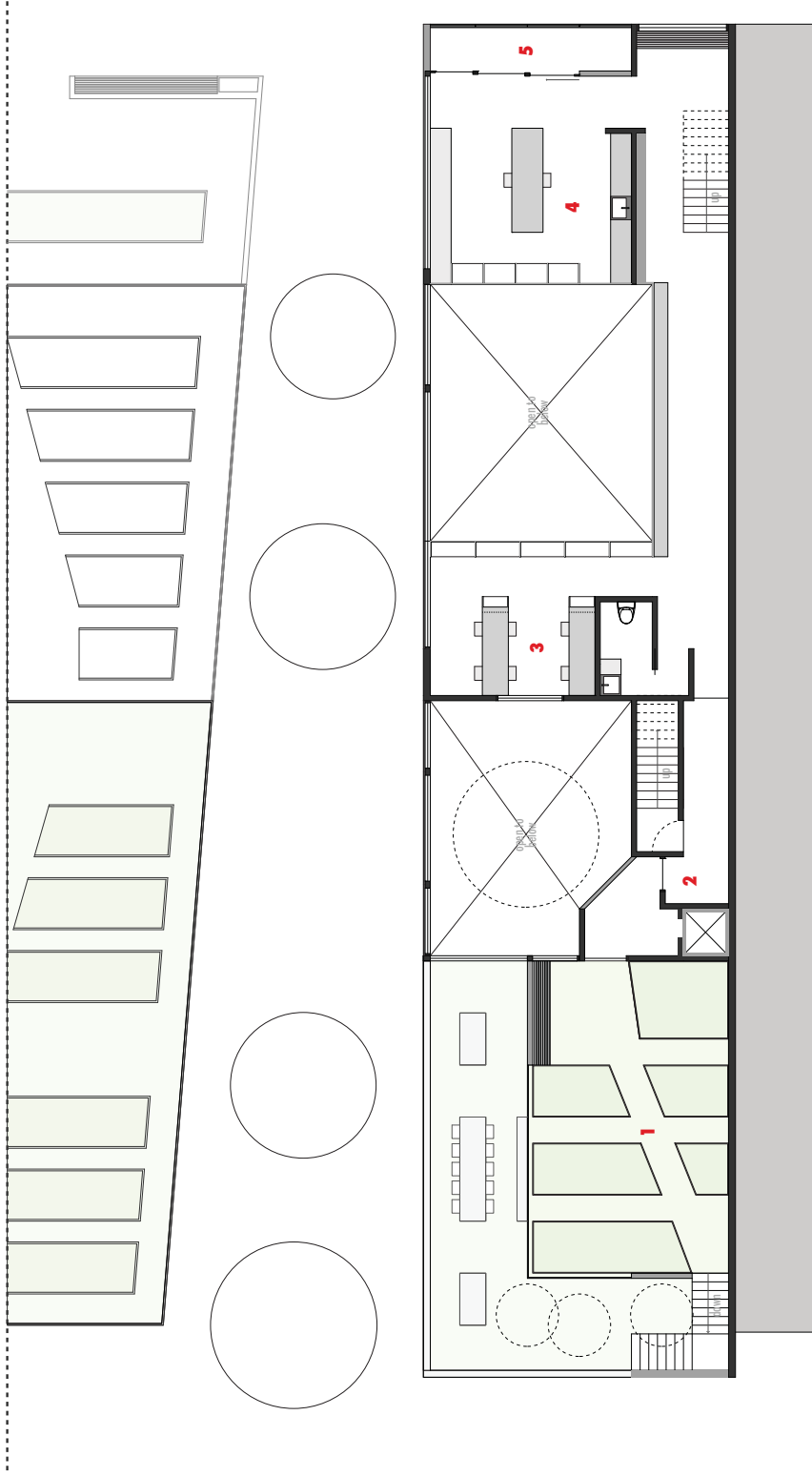

- 1 Planting beds
- 2 Roof access
- 3 Office
- 4 Studio
- 5 Covered balcony

⊖ 1:200

Fourth floor plan - vegetable garden and offices

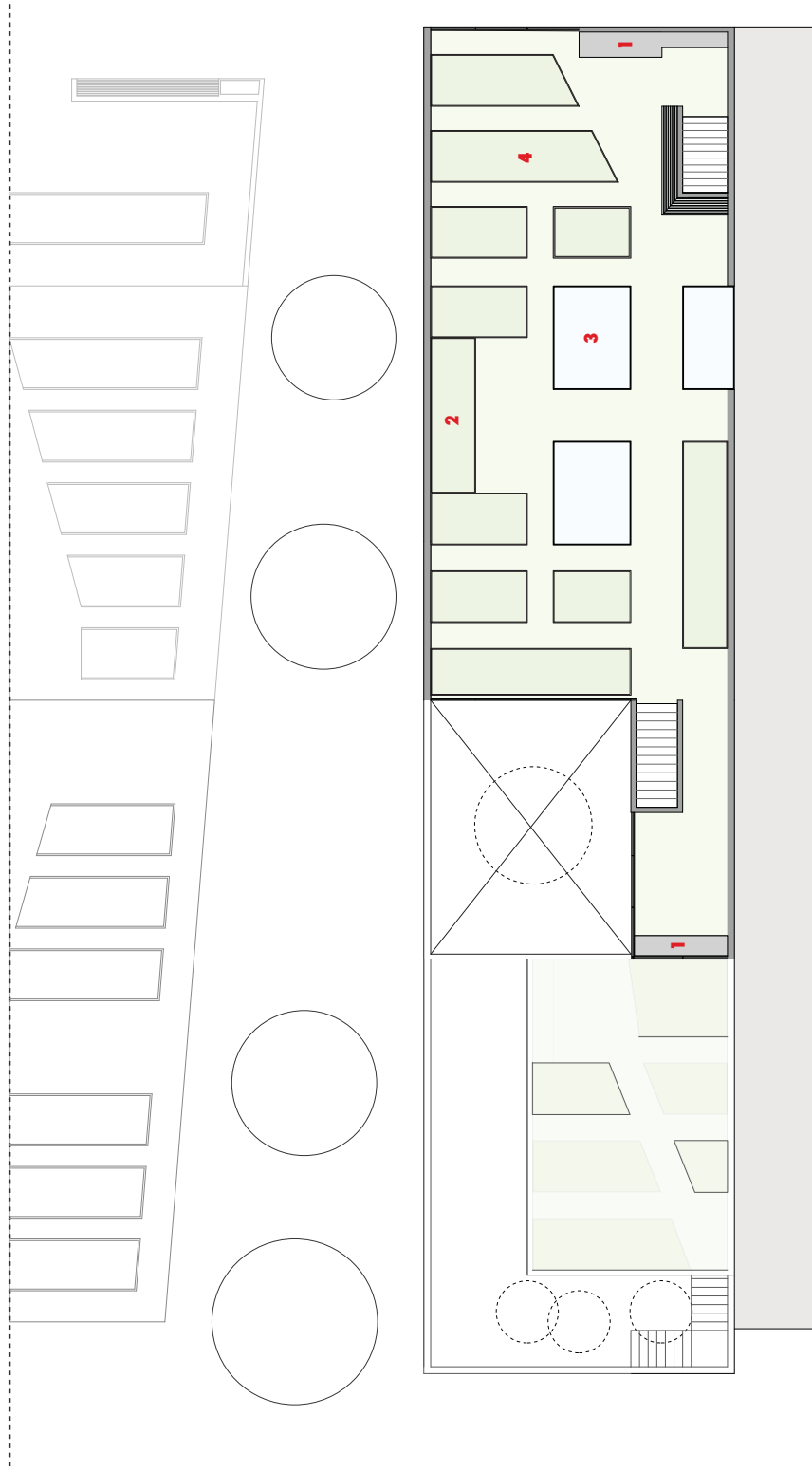

- 1 Work tables
- 2 Compost
- 3 Lightwell
- 4 Planting beds

⊖ 1:200
Roof plan



ALLEY

POWELL STREET

Longitudinal section looking east



View into market from Powell Street entry, emphasizing compression of entry, followed by a light filled atrium.



Second floor tea bar where customers can learn about tea and try a variety of samples.



Entrance of second floor *yakiniku*, with charcoal storage acting as a partial screen for the chef.



View through courtyard with contrasting materials of market (unfinished cedar) and *izakaya* (charred cedar). *Yatai* sits dormant in courtyard.



View from alley entry into izakaya. Customers are greeted by a chef at main grill station and a material palette of charred cedar and board-formed concrete

DEVELOPMENT OF URBAN SPACES

A significant component of this proposal for Japantown involves the strategic development of the existing urban fabric. Present-day Japantown is defined by a series of major and minor streets surrounding an underutilized central square (Oppenheimer Park). To remedy this urban condition additional streets and squares have been woven into the existing fabric, creating public spaces of different sizes and spatial qualities. This inventory of public spaces is intended to serve as the blueprint for future phases of development.

Transforming the service alleys from derelict and dangerous to vibrant and welcoming spaces is integral to the revitalization of Japantown. The architecture plays a vital role in this transformation, with each proposed building responding to the newly created alley frontage through open studios and kitchens. This has been augmented by a number of small-scale design elements intended to soften the alley's current, uninviting aesthetic. *Torii* gates, an important cultural icon used to denote places of cultural significance, have been created from the decommissioned service poles, while benches, maple and cherry trees and bike racks create spaces for residents and visitors to gather, watch and relax. *Yatai* act as the primary evening presence in the alley, creating a series of dining rooms within the newly defined alley edge. The expanded hours of operation for the area are also an important strategic proposal in mitigating crime and increasing urban vitality.

- STREETS**
- MAJOR ROADS
 - MINOR ROADS
 - ALLEY
- SQUARES**
- PARK

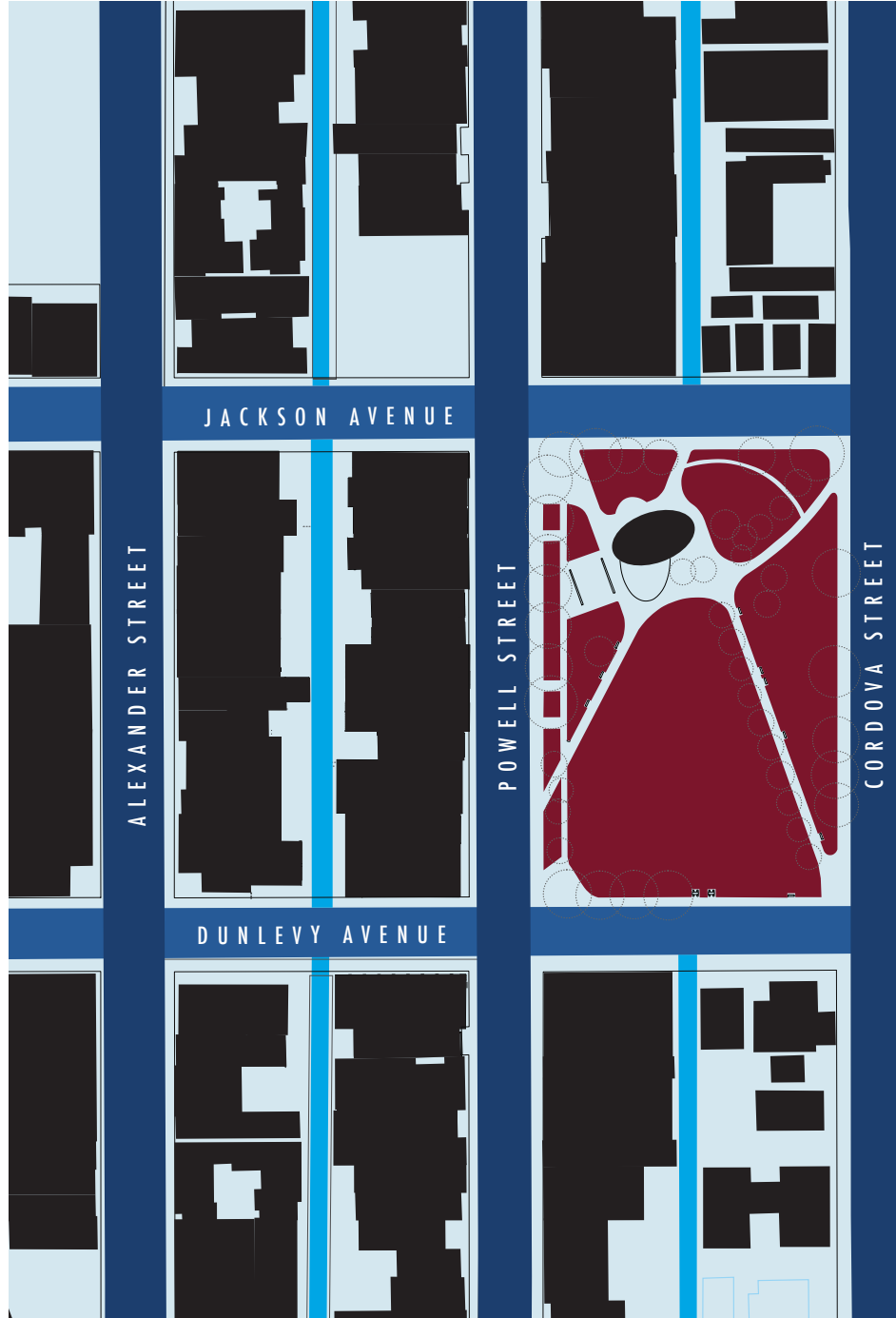

Existing public spaces in the urban fabric

- STREETS**
- MAJOR ROADS
 - MINOR ROADS
 - ALLEY
 - BREEZEWAY

- SQUARES**
- PARK
 - ALLEY EDGE
 - COURTYARD
 - ROOF GARDEN
 - ATRIUM

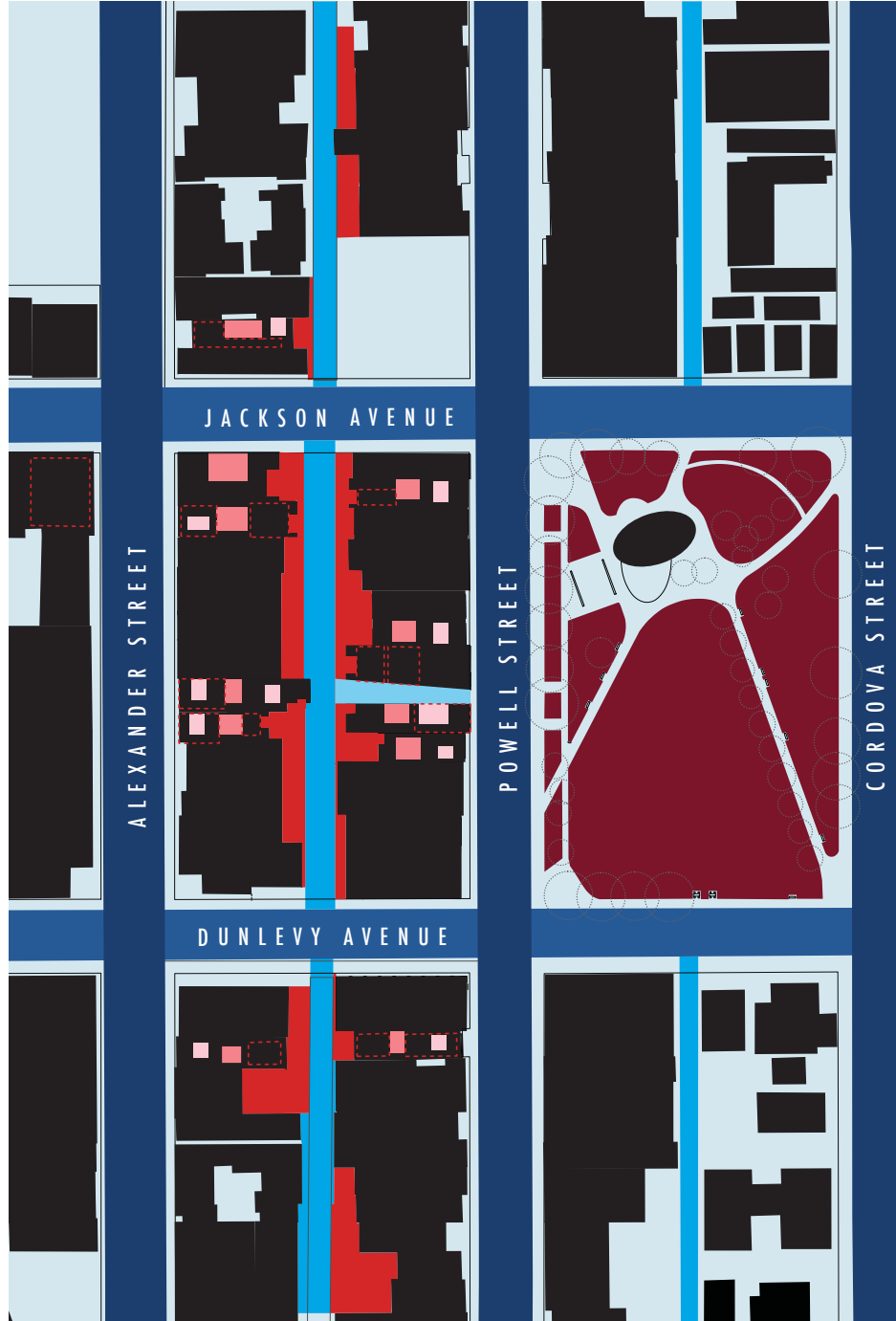

Additional public spaces in the urban fabric

STREETS

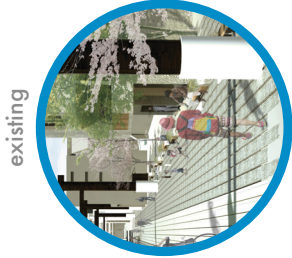

BREEZEWAY

ALLEY

MINOR STREETS

MAJOR STREETS

SQUARES



ATRIUMS

ROOF GARDENS

COURTYARDS

ALLEY EDGE

OPPENHEIMER PARK

Inventory of urban spaces added to the existing fabric

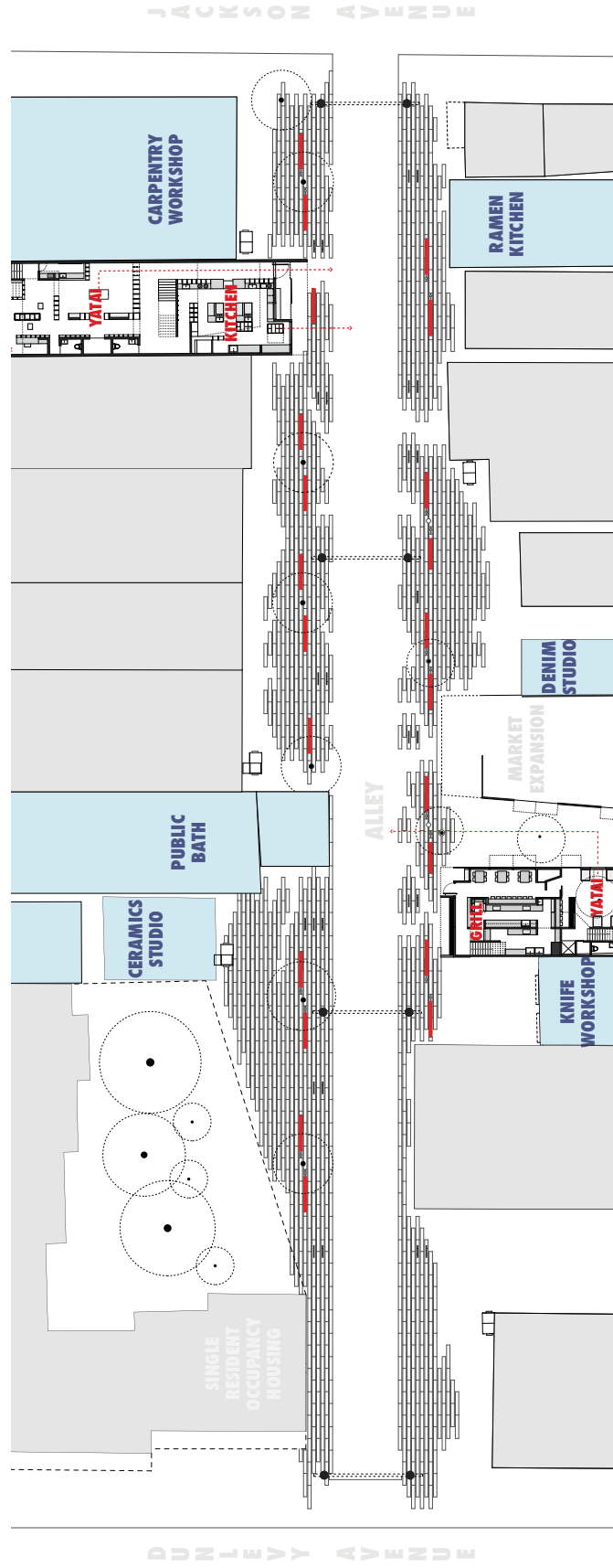

Plan of alley depicting the location of newly added pavers and relationship of proposed studio / kitchen spaces to the alley

BUILDING REMOVED

INSERT CERAMICS STUDIO

INSERT PUBLIC BATH

INSERT CARPENTRY

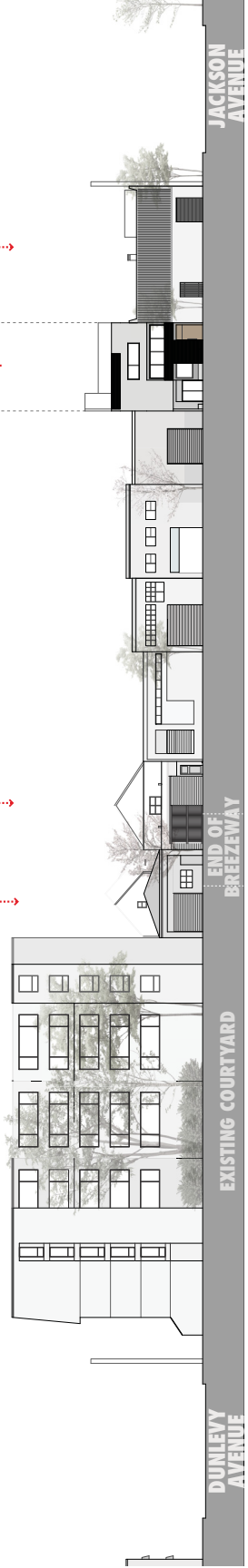

Elevation of alley, looking north

BUILDINGS REMOVED

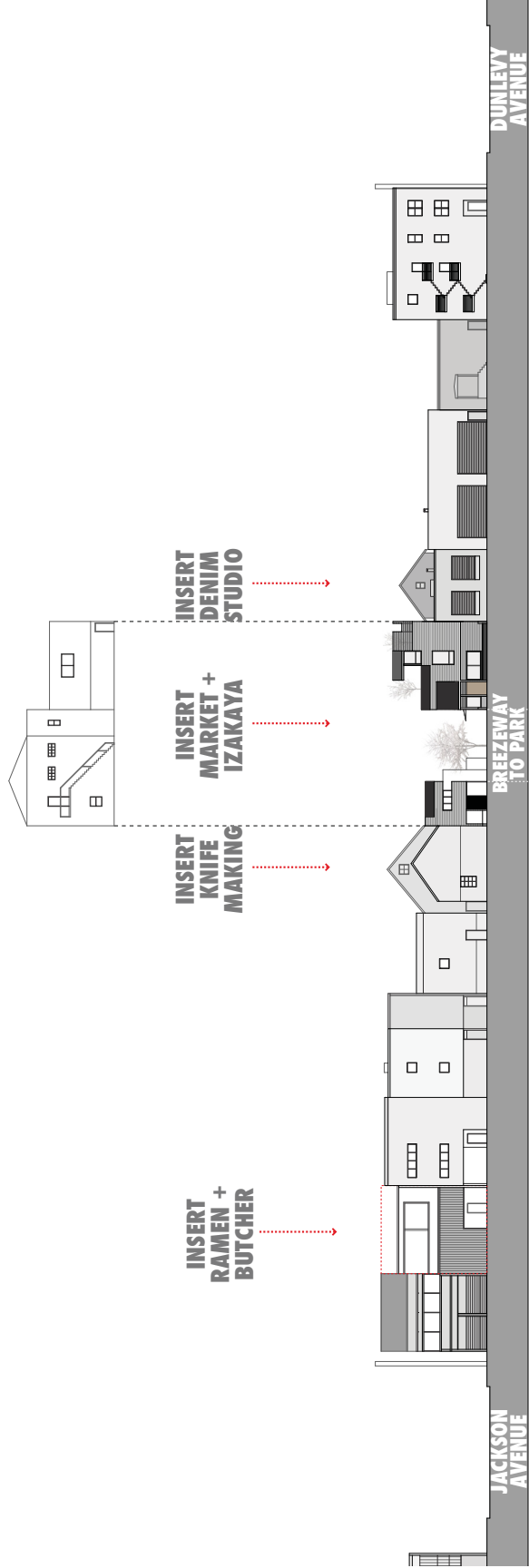

Elevation of alley, looking south



BENCHES + TREES

Benches and trees extend Oppenheimer Park into the alley and offer residents a place to sit and observe the alley's open studios



BIKE RACK

Bikes are ubiquitous in Japan and an important mode of transport for Vancouverites. By providing plenty of bicycle parking, the alleyway further encourages cycling as a means of travel.

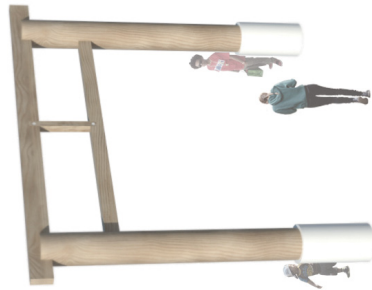

TORII

Torii gates are used to mark the entrance to sacred + culturally significant sites. Existing service poles have been re-purposed to create industrially inspired torii.

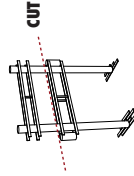

EXISTING SERVICE POLES

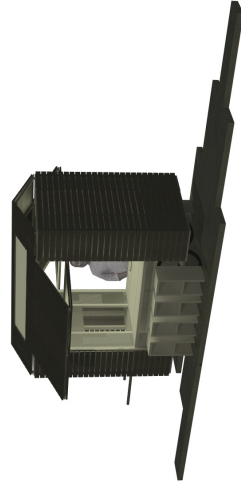

YATAI

Yatai transform the alley in the evenings from an area of concentrated crime to an impromptu dining space. Yatai also help to expand the influence of Japantown's core.

Urban elements added to the alley

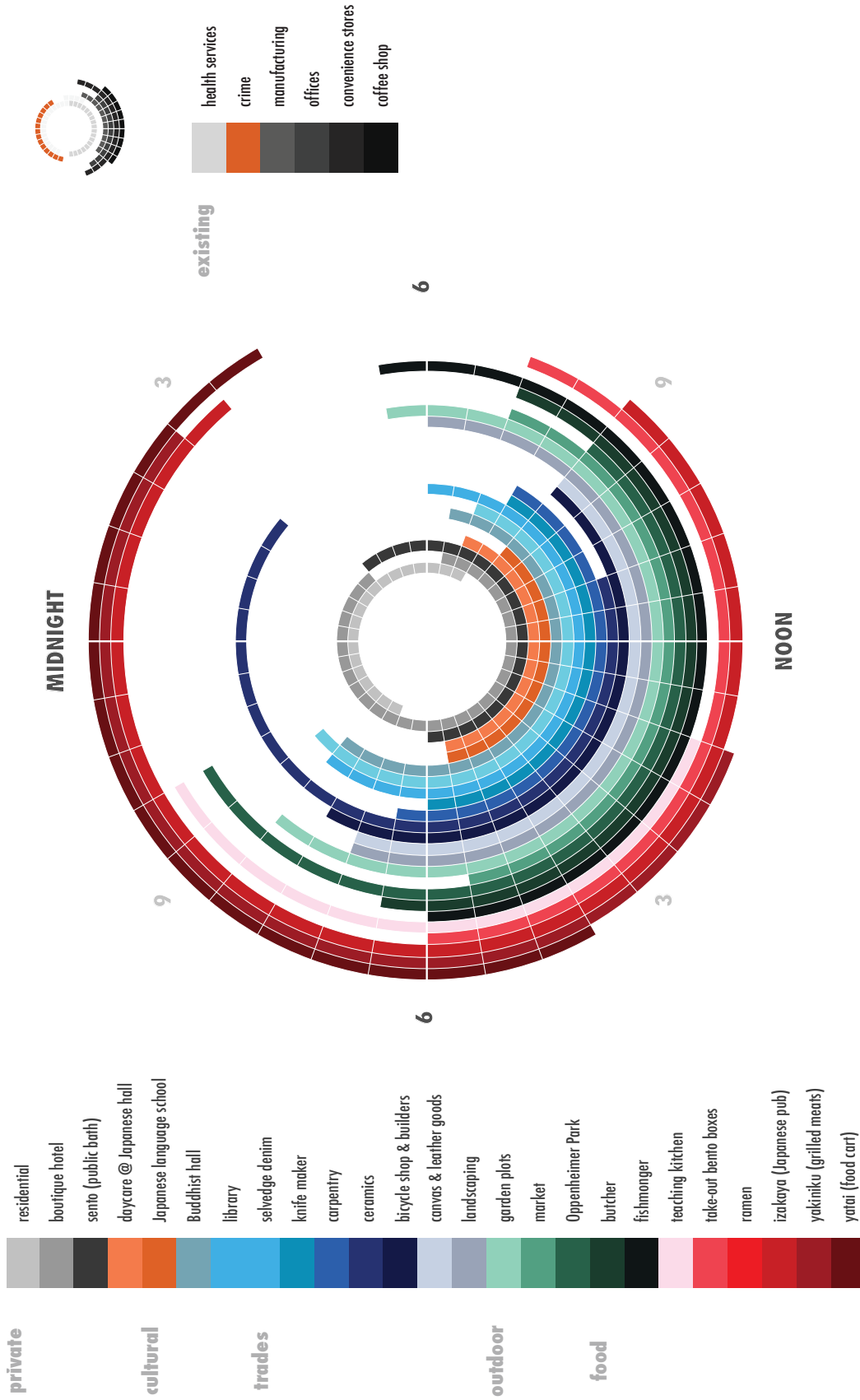

Expanded business hours created by newly proposed businesses

YATAI

Yatai are an integral component of the culinary landscape in southern Japan. These small carts and stalls transform the streets and alleys from desolate and/or underutilized spaces into lively eating venues rich in aroma and conversation. Although diminutive in stature, these *yatai*, the smallest of the proposed architectural interventions, offer the greatest potential for revitalization. Both the *izakaya* and the *bento* kitchen feature a *yatai* that combines the two programs of the building. A *yakitori yatai* acts as a symbolic reference for the *izakaya* and market, distributing grilled meats and market-sourced vegetables. The *bento* kitchen and library's *yatai* combine take-out *bento* and library books to expand the reach of the building during the day. This same formula would be applied to all new food-based programs added to the Japantown neighborhood, eventually resulting in a fleet of *yatai* defining the alleyscape.

As part of this design proposal the *yakitori yatai* was developed in detail. Although designed with a specific cooking process in mind, a number of the elements - the structural frame, general dimensions, and ideas of deployment - are intended to be applied to future variations. The following drawings illustrate the development of the *yatai*, beginning with the structural frame and considerations about weight and materials, then progressing to ideas about deployment and detailed orthographic drawings.

Prior to delving into the design of a modern *yatai* it was first necessary to examine more traditional variations to discern the elements essential to its operation. The following drawing looks at an early *yatai* from the 1920s, designed to serve *ramen* and be pulled by a single individual.

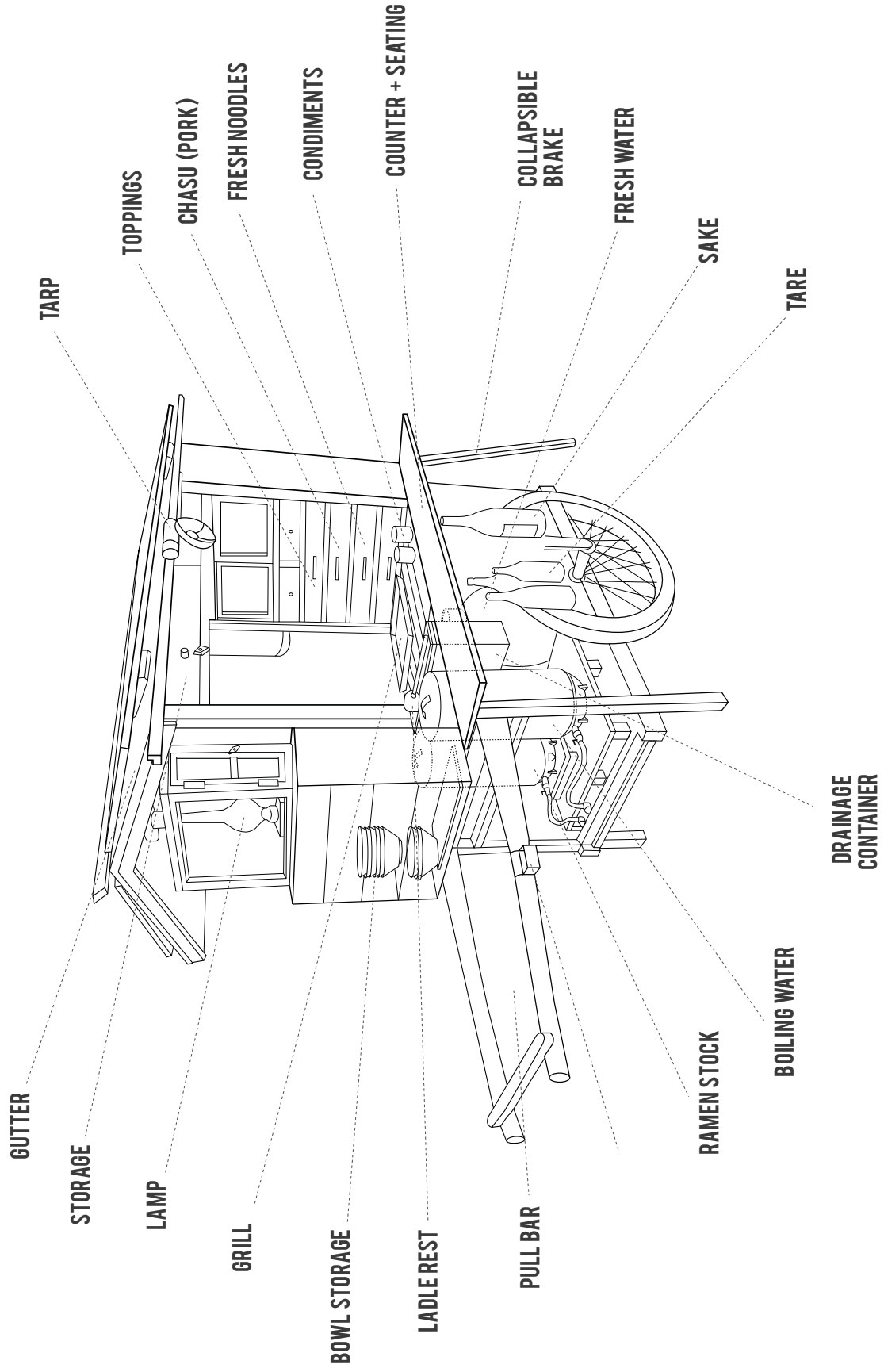

Early ramen yatai from 1920s



● POTENTIAL SITES FOR YATAI

Japantown's alleysways offer numerous locations for setting up a *yatai*.



STORAGE

COOKING

EATING

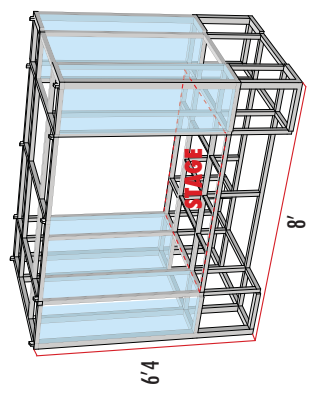

1 Structural frame serves as base for all yatai and accommodates all the necessary functions

2 WHEELS & 'C' CHANNEL TRACKS ADDED

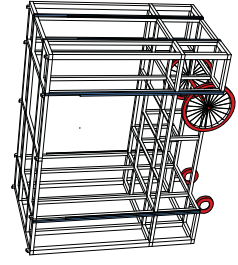

3 POWDER COATED ALUMINUM PANELS

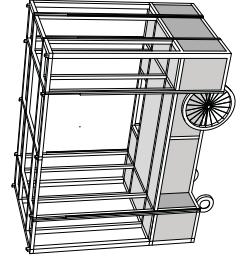

4 PLEXI SANDWICHED SHOJI PANELS CREATE LANTERNS

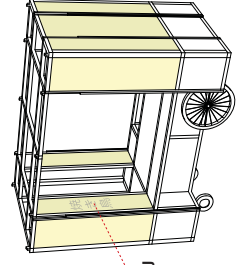

5 DYNAMIC FRAMES ADDED

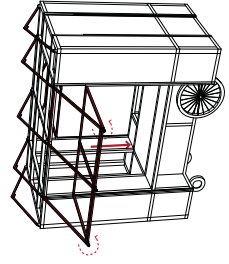

6 ROOF EMITS LIGHT & ALLOWS AIR FROM GRILL TO CIRCULATE

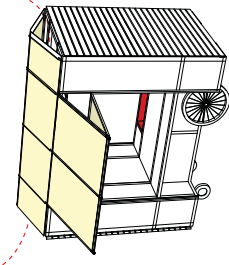

7 CHARRED CEDAR CLADDING, PULL BAR, AND STOOLS ADDED

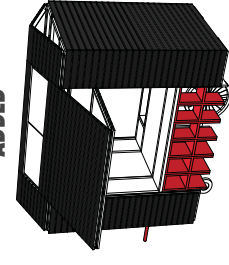

Structural frame can be modified to meet the needs of each yatai. Yakitori yatai shown here.

APPROXIMATE WEIGHT

YAKINIKU YATAI

508 lbs

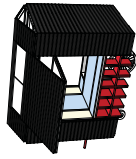

CEDAR 96 lbs

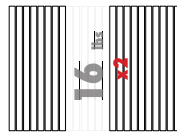
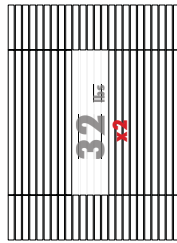

3 oz. / linear foot

PLEXI & WASHI 98 lbs



0.89 lbs / sq ft

STRUCTURAL FRAME 180 lbs

Aluminum chosen for weight to ensure that yatai can be easily pushed by two people and the screen can easily be operated by a single person



STEEL
1.8 lbs / linear foot



ALUMINUM
0.9 lbs / linear foot

METAL PANELS 42 lbs



0.86 lbs / sq ft → 1/8 gauge powder-coated aluminum

COUNTERTOP 24 lbs

1.68 lbs/sq ft → 10 gauge powder coated aluminum



Study calculating the approximate weight of proposed materials, compared to other iconic, mobile objects

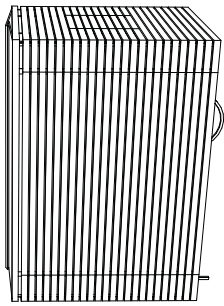

**YATAI
PARKED
DURING
DAY**

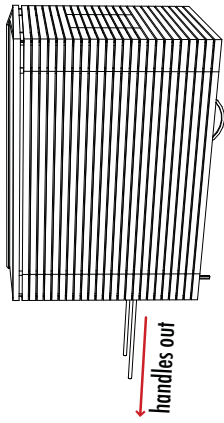

**PULL OUT
HANDLES +
MOVE TO
SITE**

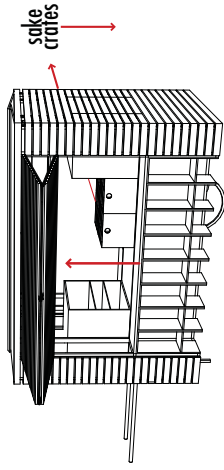

**SCREEN
OPENS +
CREATES
OVERHANG**

roof raised
with screw jack

light emitted
from ends

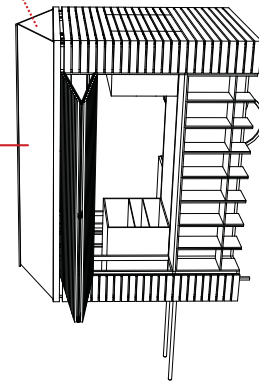

**ROOF
BECOMES
LANTERN**

bowl storage
handles in

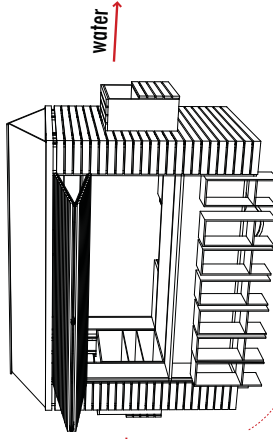

**CHARCOAL
HEATED +
STOOLS
SET-OUT**

chairs out + cooking begins

water

Yatais sit dormant in the buildings during the day and transform the alleys into a vibrant eating space in the evenings.

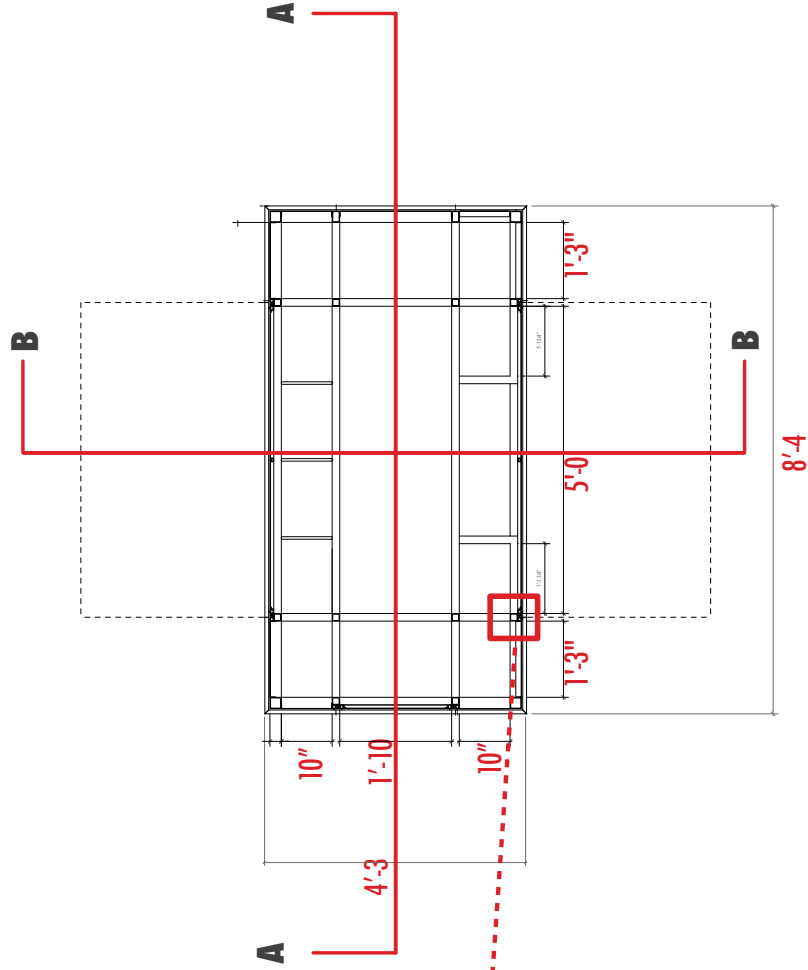

PLAN

SCREEN & TRACK

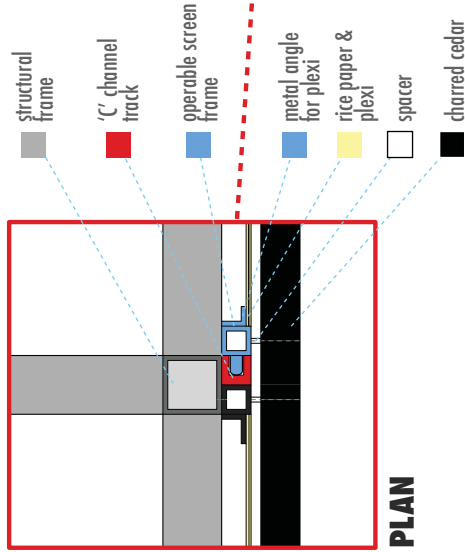

PLAN

Yatai plan and detail of track for operable screen

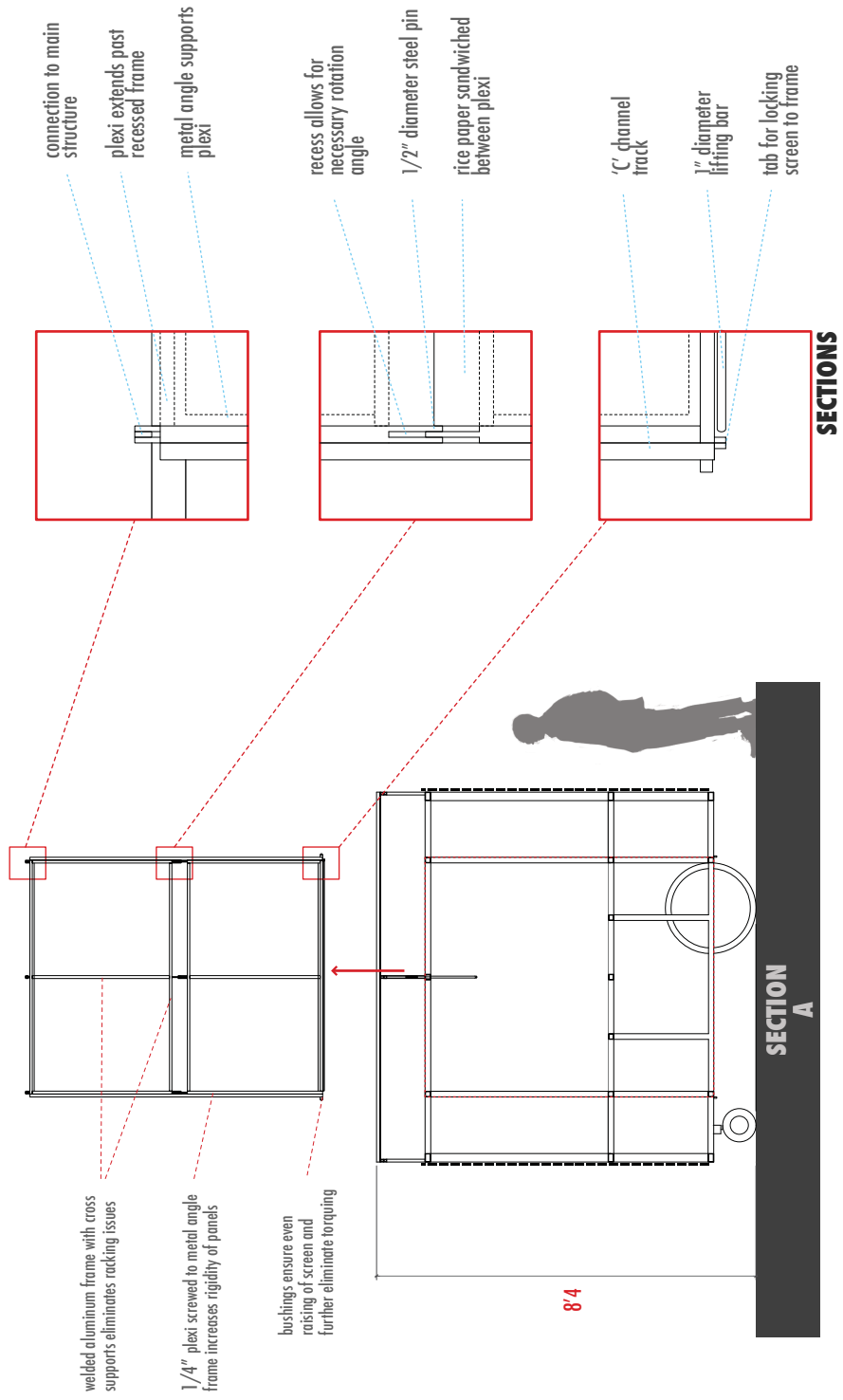

Section through *yatai* and additional details for operable screen

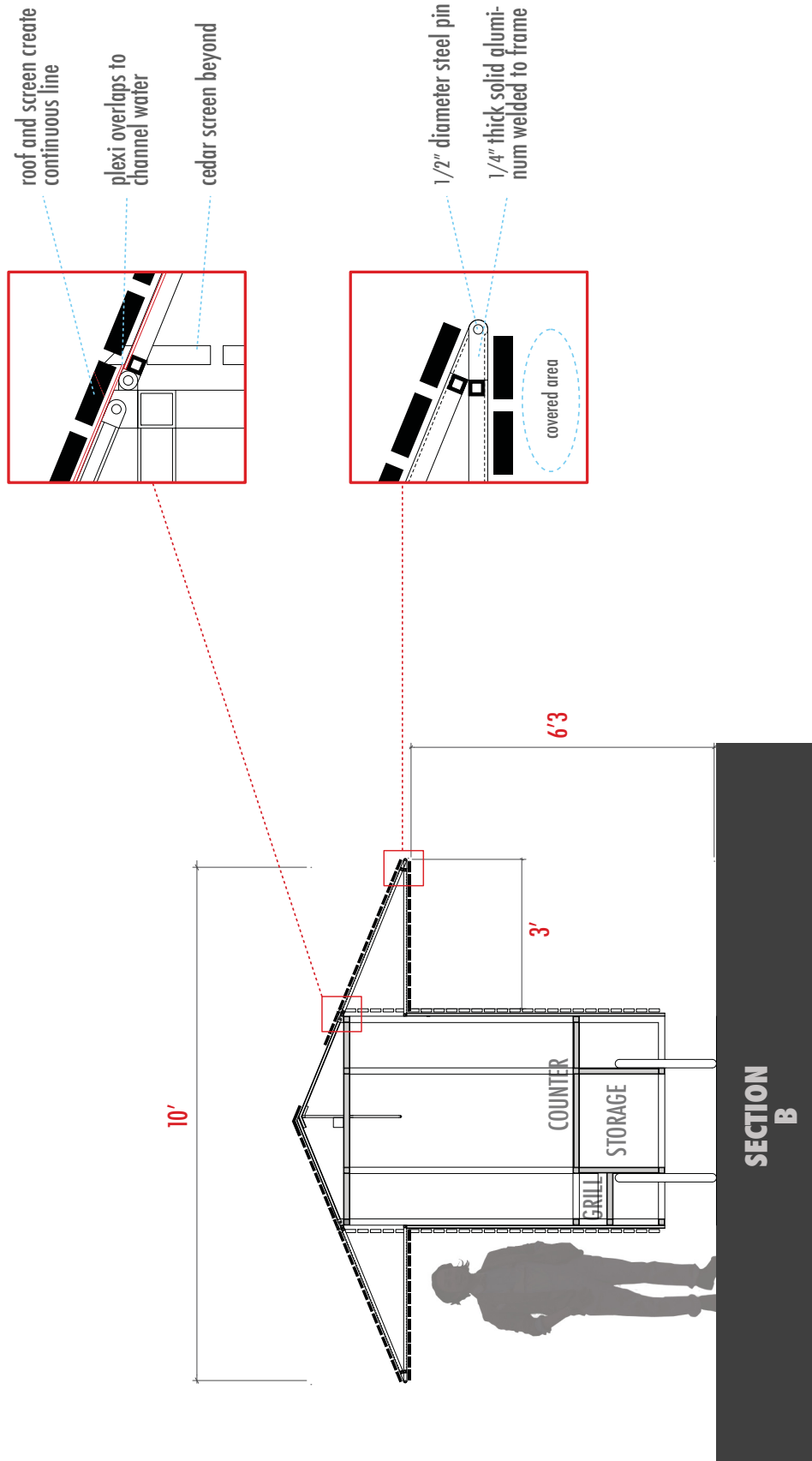

Section B - open yatai with operable screen providing protection from sun and rain

CHAPTER 3: CONCLUSION

The complex social and urban conditions currently ailing Vancouver's Japantown need to be addressed at a number of scales and in a number of ways, beyond the capacity of Japanese food alone. Although this thesis focuses on the development of two buildings driven by the production and consumption of Japanese food, equally important is the creation of an urban strategy to strengthen and refine the existing urban fabric. Japanese food and the architectural spaces that it influenced were used to explore how neighborhoods function and how they can be constructed at different scales.

Also embedded in the project is a strong sense of sociability. In some ways, this acknowledges the social nature of food, but it is also a conscious design decision intended to promote community and seeds for future development. The architecture, at all scales, was not conceived as being just a building (or just a food cart), but instead was designed as a piece of the city, giving back to those who had no part in its commissioning. Central to the re-establishment of severed cultural ties is the reconnection of the architecture to the city or in this case making the architecture part of the city.

Reflecting upon the thesis question that generated this body of work, it is apparent that the act of "making" has come to define more than just the architecture of Japantown; it has become the neighborhood's identity. This approach demanded a more cohesive architectural strategy and made the thesis less about an architectural response to food and more about an architectural response to urban conditions.

It is interesting to consider how a future proposal might build on this proposed urban framework and its programmatic ideas. Using the sensibility of food to reflect on one's work as an architect was an enlightening experience that could be adapted to other urban situations.

REFERENCES

- Barthes, Roland. 1982. *Empire of Signs*. New York: Hill and Wang.
- Birmingham and Wood. 2007. *Historical and Cultural Review Powell Street (Japantown)*. Vancouver: City of Vancouver.
- Buntrock, Dana. 2010. *Materials and Meaning in Contemporary Japanese Architecture*. New York: Routledge.
- City of Vancouver. 2010. *Zoning and Development*. <http://vancouver.ca/commsvcs/bylaws/zoning/zon&dev.htm> (accessed Oct. 18, 2011).
- Gumi, Tonari. 2010. *The Spirit of Issei*. Vancouver: Ti-Jean Press.
- Isozaki, Arata. 2011. *Japan-ness in Architecture*. Cambridge: MIT Press.
- Jiro Dreams of Sushi*. 2011. Directed by David Gelb. New York: Preferred Content Studios. Motion Picture.
- Kliman, Todd. 2011. The Problem of Authenticity. *Lucky Peach* 1, no. 1: 82-92.
- McAllister, Kiersten Emiko. 2010. *Terrain of Memory: A Japanese Canadian Memorial Project*. Vancouver: UBC Press.
- Meehan, Peter. 2011. Things Were Eaten. *Lucky Peach* 1, no. 1: 5-19.
- Okakura, Kazuko. 2009. *The Book of Tea*. Rockville, MD: Serenity Publishers.
- Pollan, Michael. 2009. *In Defense of Food: An Eater's Manifesto*. New York: Penguin Press.
- Robinson, Greg. 2009. *A Tragedy of Democracy*. New York: Columbia University Press.

- Royal British Columbia Museum. 2012. *British Columbia Archives*. http://www.bcarchives.gov.bc.ca/cgi-bin/www2m/Visual_Records_Subjects?JAPANESE+CANADIANS (accessed May 24).
- Schittich, Christian. 2002. *In Detail: Japan. Architecture and Aesthetic of an Island People*, 15-45. Berlin: Birkhauser.
- Tampopo*. 1985. Directed by Juzo Itami. Tokyo: Itami Productions, 2001. DVD.
- Tanizaki, Junichiro. 1977. *In Praise of Shadows*. New Haven: Leete's Island Books.
- Taylor, Mary. 2004. *A Black Mark: The Japanese Canadians in WW II*. Ottawa: Oberon Press.
- Tokyo Institute of Technology, Tsukamoto Architectural Laboratory and Atelier Bow-wow. 2002. *Pet Architecture Guidebook*. Tokyo: World Photo Press.

APPENDIX: LESSONS FROM CHINATOWN

2 LOW QUALITY GOODS ARE UNSUSTAINABLE

A number of shops in Chinatown's retail core have resorted to selling low quality goods imported from China, and disposable souvenirs. In small numbers these vendors offer an important service, but over time they have come to dominate Chinatown undermining its appeal and sustainability.



3 AVOID AN EXCESS OF CULTURALLY SPECIFIC PRODUCTS

A large number of shops located in Chinatown cater primarily to the Chinese-Canadian population, which has left them vulnerable to the demographic shift in the neighborhood. As real estate prices escalated and younger generations of Chinese-Canadians opted for land and lower prices in Richmond the local economy suffered.

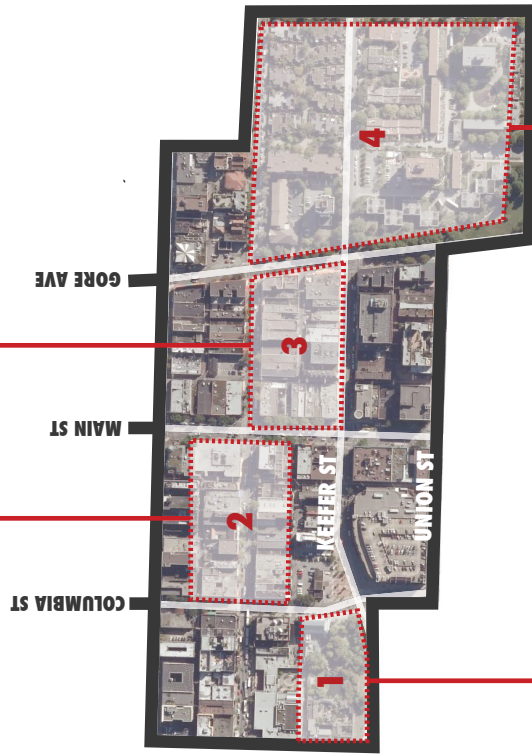

PROVIDE FOR DAILY NEEDS

Inclusive businesses allow for a more culturally diverse customer base and increases foottraffic. Chinatown's butcher, bakeries, fishmongers, and markets remain the most vibrant components of the community.



CHINATOWN NIGHTMARKET

The summer nightmarket and the various cultural festivals that populate Chinatown bring Vancouverites from around the city injecting income into the local businesses and exposing visitors to the neighborhood's unique offerings.

1 ENSURE CULTURAL ICONS ARE CENTRALLY LOCATED

Home to the Chinese cultural center and Dr. Sun Yat Sen Gardens this area of Chinatown is an important component for the Chinese-Canadian community Vancouverites and tourists. However, its separation from the daily life of detracts from its importance.



4 PROVIDE A VARIETY OF HOUSING OPTIONS

The Chinatown / Strathcona neighborhood used to offer a wide variety of housing options for a variety of demographics. This resulted in a wellbalanced and diverse community. In recent years a rapid escalation in housing prices has not been addressed foraging lower income earners, most notably small business owners, immigrants and young adults to move further east.