

**Building Rural Solutions from Rural Conditions:  
Revitalizing Cambodian Fishing Communities through  
Environmental Education**

by

Shallyn Murray

Submitted in partial fulfilment of the requirements  
for the degree of Master of Architecture

at

Dalhousie University  
Halifax, Nova Scotia  
March 2012

© Copyright by Shallyn Murray, 2012

**DALHOUSIE UNIVERSITY**  
**SCHOOL OF ARCHITECTURE**

The undersigned hereby certify that they have read and recommend to the Faculty of Graduate Studies for acceptance a thesis entitled “Building Rural Solutions from Rural Conditions: Revitalizing Cambodian Fishing Communities through Environmental Education” by Shallyn Murray in partial fulfilment of the requirements for the degree of Master of Architecture.

Dated: March 19, 2012

Supervisor: \_\_\_\_\_

Reader: \_\_\_\_\_

Reader: \_\_\_\_\_

DALHOUSIE UNIVERSITY

Date: March 19, 2012

AUTHOR: Shallyn Murray

TITLE: Building Rural Solutions from Rural Conditions: Revitalizing Cambodian Fishing Communities through Environmental Education

DEPARTMENT OR SCHOOL: School of Architecture

DEGREE: MArch CONVOCATION: May YEAR: 2012

Permission is herewith granted to Dalhousie University to circulate and to have copied for non-commercial purposes, at its discretion, the above title upon the request of individuals or institutions. I understand that my thesis will be electronically available to the public.

The author reserves other publication rights, and neither the thesis nor extensive extracts from it may be printed or otherwise reproduced without the author's written permission.

The author attests that permission has been obtained for the use of any copyrighted material appearing in the thesis (other than brief excerpts requiring only proper acknowledgement in scholarly writing), and that all such use is clearly acknowledged.

---

Signature of Author

# CONTENTS

ABSTRACT .....	v
ACKNOWLEDGEMENTS.....	vi
CHAPTER 1: INTRODUCTION .....	1
RURAL DEVELOPMENT .....	1
What is Rural Development? .....	1
Cambodia and Rural Development .....	2
CONTEXT .....	3
Cambodia.....	3
Tonle Sap Lake .....	4
Kompong Phluk.....	7
EXISTING ARCHITECTURE.....	14
The Vernacular .....	14
Architecture of Kompong Phluk .....	14
Case Study .....	17
ENVIRONMENTAL EDUCATION.....	24
Education as a Development Strategy .....	24
Building Program .....	25
User Groups .....	28
CHAPTER 2: DESIGN.....	29
PHASE 1 EDUCATION CENTER .....	30
Site Strategy .....	30
Evolution.....	31
Building Systems .....	39
PHASE 2 WASTE PROCESSING .....	50
Objectives.....	52
CHAPTER 3: CONCLUSION .....	57
AFTERWORD .....	58
REFERENCES .....	60

## ABSTRACT

This thesis aims to create an architecture that adapts and integrates modern sustainable building solutions with Cambodian vernacular architecture to improve the quality of dwelling in rural fishing communities in Cambodia. The design draws upon local culture, materials and building methods to develop community facilities that will aid the rural population in preserving natural resources. The ultimate goal is to advance sustainable development, socially, economically and architecturally.

The site is located in the small stilt fishing commune of Kompong Phluk on Tonle Sap Lake in Cambodia. The program is an N.G.O.- supported Education Exchange Center that focuses on mobilizing environmental education to adjacent lake communities in order to sustainably manage rapidly depleting fish stocks in the lake.

## ACKNOWLEDGEMENTS

This work would not have been possible without the support and guidance of many. Thank you to everyone who contributed to this research.

I would like to extend a special thanks to my supervisor, Christine Macy, for her inspirational advice, support and friendship. I would also like to express my heartfelt appreciation to her and to Sarah Bonnemaïson for sparking my interest in culture and architecture through the development of an inspiring international studio in 2010.

I would also like to thank my advisor Richard Kroeker, whose expansive knowledge and experience working with vernacular architecture has extended the depth and success of this research.

Thank you to Hok Sokol, Pros Ing, and Don and Kheang of Rana Homestay, who made my study in Cambodia an unforgettable learning experience. I would also like to thank Melissa Marschke, whose work in Kompong Phluk was of immeasurable importance to this thesis.

I would like to dedicate this work to my parents, Carla and Rodney Murray, for supporting me in everything I do.

## CHAPTER 1: INTRODUCTION

Architecture has largely been fascinated by urban centers, focusing on the development of the city and its inhabitants. This project turns its focus toward the rural poor that make up the majority of the population. It explores rural development as a strategy for improving the living conditions of Cambodia's fishing communities. Its intention is to create new opportunities in rural areas in two ways:

(1) architecturally, through the creation of an environmental education center that encourages sustainable use of resources and propels improvements in the quality of residential dwellings,

(2) economically, through the development of new skills and employment opportunities to diversify livelihood strategies.

## RURAL DEVELOPMENT

### What is Rural Development?

Rural development, as defined by the Bruntland Report, is "the requirement to meet the basic needs of all and extending to all the opportunity to fulfill their aspirations for a better life" (Bruntland Report 1987, 8). The development of rural populations became a primary consideration in the development of third world countries when it was realized that urban development was only increasing the poverty of the rural poor, which was in most cases, 80-90% of the total population (Schumacher 1974, 163). The rural

poor migrating to cities seeking more opportunities were instead finding themselves homeless and without the skills, knowledge or capital to obtain urban employment.

Schumacher calls this dynamic the 'dual economy theory', in which "successful industrial development in the cities destroys the economic structure of the hinterland and the hinterland takes its revenge by mass integration into the cities, poisoning them and making them utterly unmanageable" (Schumacher 1974, 163). He argues that workplaces need to be created in areas where people live - even if rural - and each region should have its own type of development that suits its particular needs.

### **Cambodia and Rural Development**

Rural development has always been seen as a "tool for socio-economic development in Cambodia" (Chan 2008, 11). This rural focus stems from the fact that an overwhelming amount of Cambodia's poor population is rural; of the 43% of Cambodians living below the poverty line, 84% live in rural areas (Marshcke 2005, 32). Strategies for rural development, including decentralization of government officials and policy-makers, were reintroduced and widely distributed throughout the country in 2002 (Chan 2008, 11). Nonetheless, of the many non-government organizations (N.G.O.s) devoted to rural progress, almost none of them are located in rural regions.



## CONTEXT

### Cambodia

Cambodia is a Southeast Asian country located in the southern portion of the Indochina peninsula. It is home to some of the harshest environmental conditions in the world, having temperature highs of up to 40 °C with 80% relative humidity and little breeze to speak of. The yearly cycle has two seasons: dry and monsoon. The flooding from the monsoon is in addition to the 'normal' flooding Cambodia receives every year when its main water source, the Tonle Sap, reverses flow and heads inland.

Over the last two decades, there has been rapid development in the country's two main urban centers, Siem Reap and Phnom Penh. This is mainly due to international recognition of the Angkor temples in Siem Reap. This increase in tourism has created an influx of modern solutions and materials, neither of which support local resources or labor. Rural residents are moving to urban centers to fill tourism-related jobs and abandoning the agricultural way of life that has long sustained food security. Small communities have lost pride in their cultural traditions and skills, which will soon disappear if steps are not taken to counteract this trend.

A very crucial and recent part of Cambodian history is the Khmer Rouge Regime, which came to power gradually during the United States - Vietnam war in the 1960s and consolidated their rule in 1975, until their collapse with a Vietnamese invasion in 1979.



Map of South East Asia

This regime put the entire country under slavery for the purpose of agricultural reform and ultimately led to widespread famine (Saunders 2008, 29). During this time, an estimated 2 million Cambodian people were killed, mainly those who were educated or held positions of power.

In 1991, a comprehensive settlement led to the re-establishment of a constitutional monarchy and the beginning of reconstruction. The end of the regime left many residents without money, land or opportunity. Migrants flocked to rural areas to take advantage of the abundance of natural resources in which they could generate income and sustain food supply. This put further strain on the natural resource base, from which many rural Cambodians are still suffering.

### **Tonle Sap Lake**

Tonle Sap Lake is known as 'the heart' of Cambodia because it has long supported the residents of the country in supplying food and income. It is the largest freshwater lake in Southeast Asia and is estimated to yield between 289 000 - 431 000 tonnes of fish per year (Baran 2005, 26). More than 1 million people (8% of the population) depend solely on Tonle Sap Lake to generate income and it is estimated that more than 75% of Cambodians rely on the fishery for food or employment. The importance of Tonle Sap Lake to the Cambodian people resulted in it becoming a protected UNESCO biosphere reserve in 1997.

Tonle Sap Lake is part of an extremely unique hydrological system in which the lake reverses flow

and floods inland from May-October every year. Snow melting in the Himalayan Mountains combined with increased rains causes an increase in flow in the Mekong River. This increase in water level causes the Tonle Sap River to reverse its flow and backup into Tonle Sap Lake, expanding the lake from 2 600 km<sup>2</sup> in the dry season to 10 500 km<sup>2</sup> in the monsoon season. The depth in the lake increases from 1m to 10m in many areas and floods the stilt villages that surround the lake.

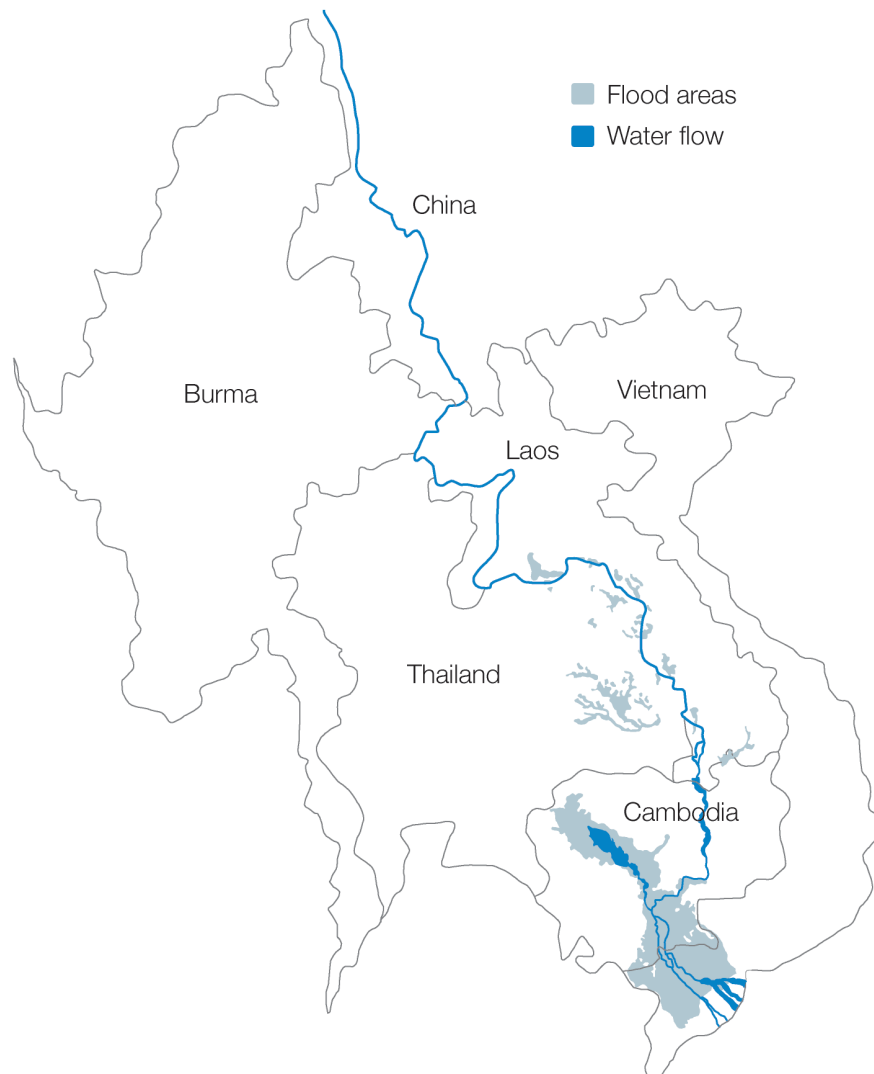

Flow of water from the Himalayan Mountains to Vietnam

The lake is surrounded by a flooded forest that thrives in these inundating conditions. The vegetation creates bountiful fishing grounds in the monsoon season and attracts migrating fish from many locations along the Mekong River. The various tree species provide protection for the village dwellings from the wind and storms that arrive with the monsoon months. They are also used for construction materials and firewood in the surrounding villages.

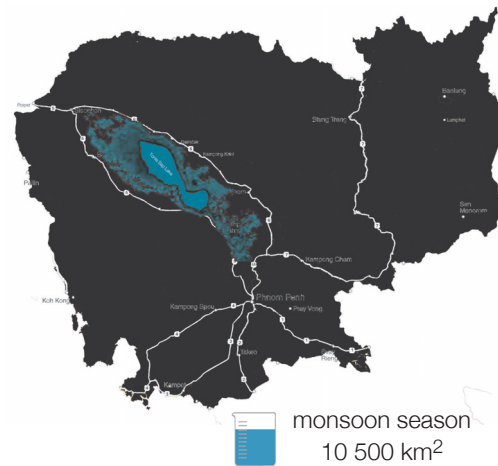
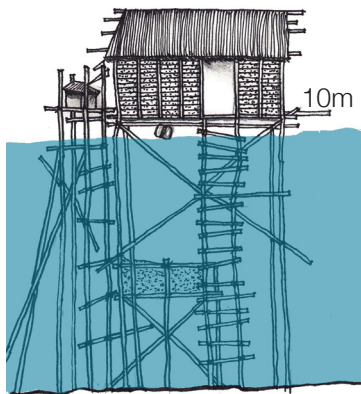
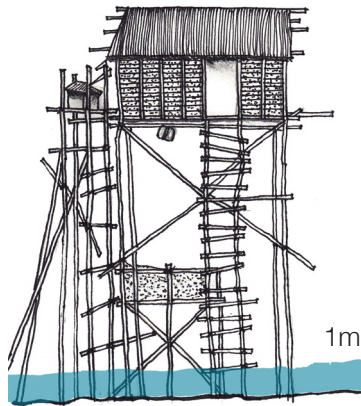

Fluctuating water levels in Tonle Sap Lake

## Kompong Phluk

Kompong Phluk is a commune on Tonle Sap Lake in central Cambodia. It is made up of three villages and contains over 3000 residents. The commune represents only three of the 80 villages that reside on and around the lake. These communities are heavily dependent on natural resources with 86% of residents' income being solely based on fishing or fish production activities (Marschke 2005, 58). Residents also rely heavily on the flooded forests that protect their homes from wind and storms and attract migrating fish during the flood season. The extreme change in water level has led to a seasonal migration pattern in which the villagers move out to temporary homes in the lake during the dry season to continue fishing, and move back to their permanent homes in the village during the monsoon to avoid bad weather.

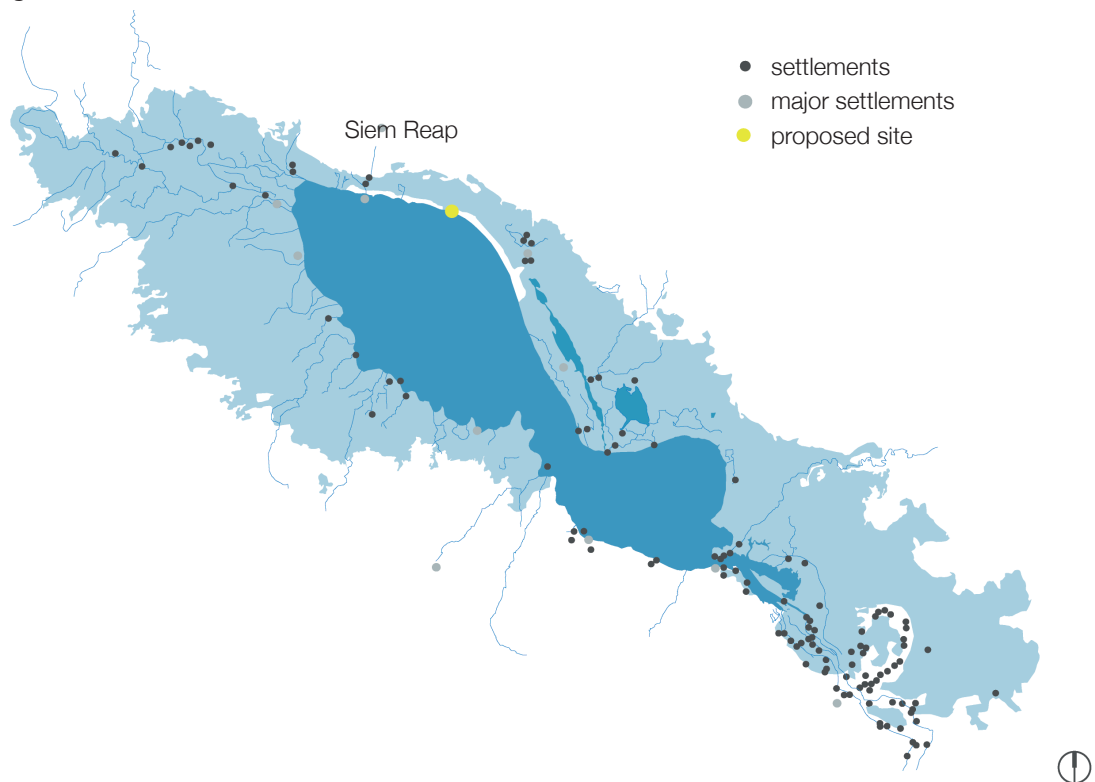

Map of villages along Tonle Sap Lake

Following the collapse of the Khmer Rouge regime in 1979, many Cambodians had to rely solely on natural resources to sustain their livelihoods, increasing the amount of fishers in the Tonle Sap Lake from 300 000 to 1.2 million. The effect, combined with government control of fishing lots, destruction of habitat and uncontrolled export, was rapid depletion of fish stocks in the lake. As a response to this destructive and inequitable resource exploitation, Kompong Phluk began to organize themselves to find ways of protecting and better managing their resources. They have been implementing strategies for protecting their environmental resources since the 1940s and in 1999 they established a formal Resource Management Committee with the help of the Food and Agricultural Organization (F.A.O.) N.G.O. (Marschke 2005, 59). The resource management strategies implemented within the commune have aided the villages both in managing their resources and diversifying their livelihoods for future opportunities outside the village (Marschke 2005, 64).

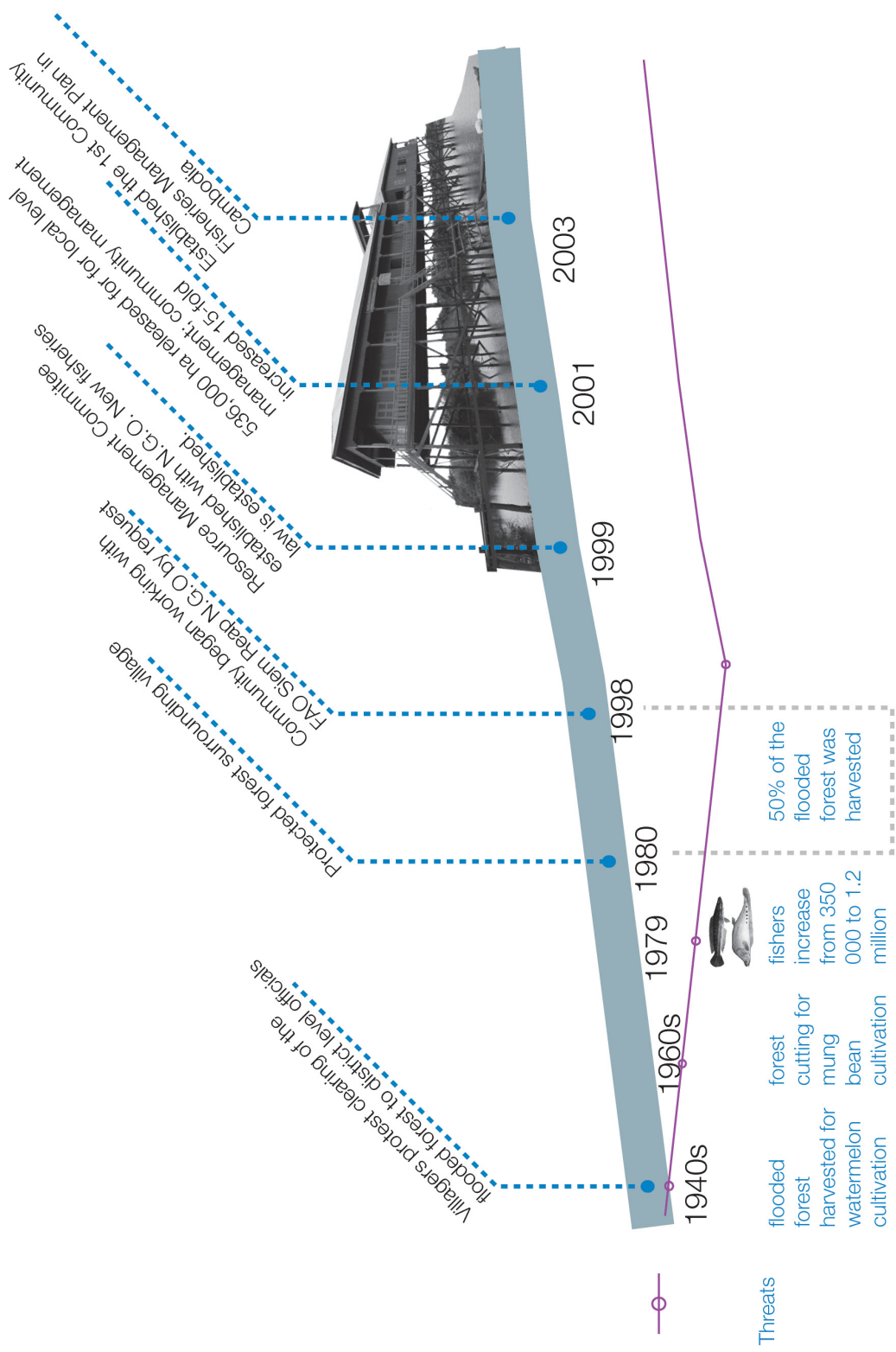

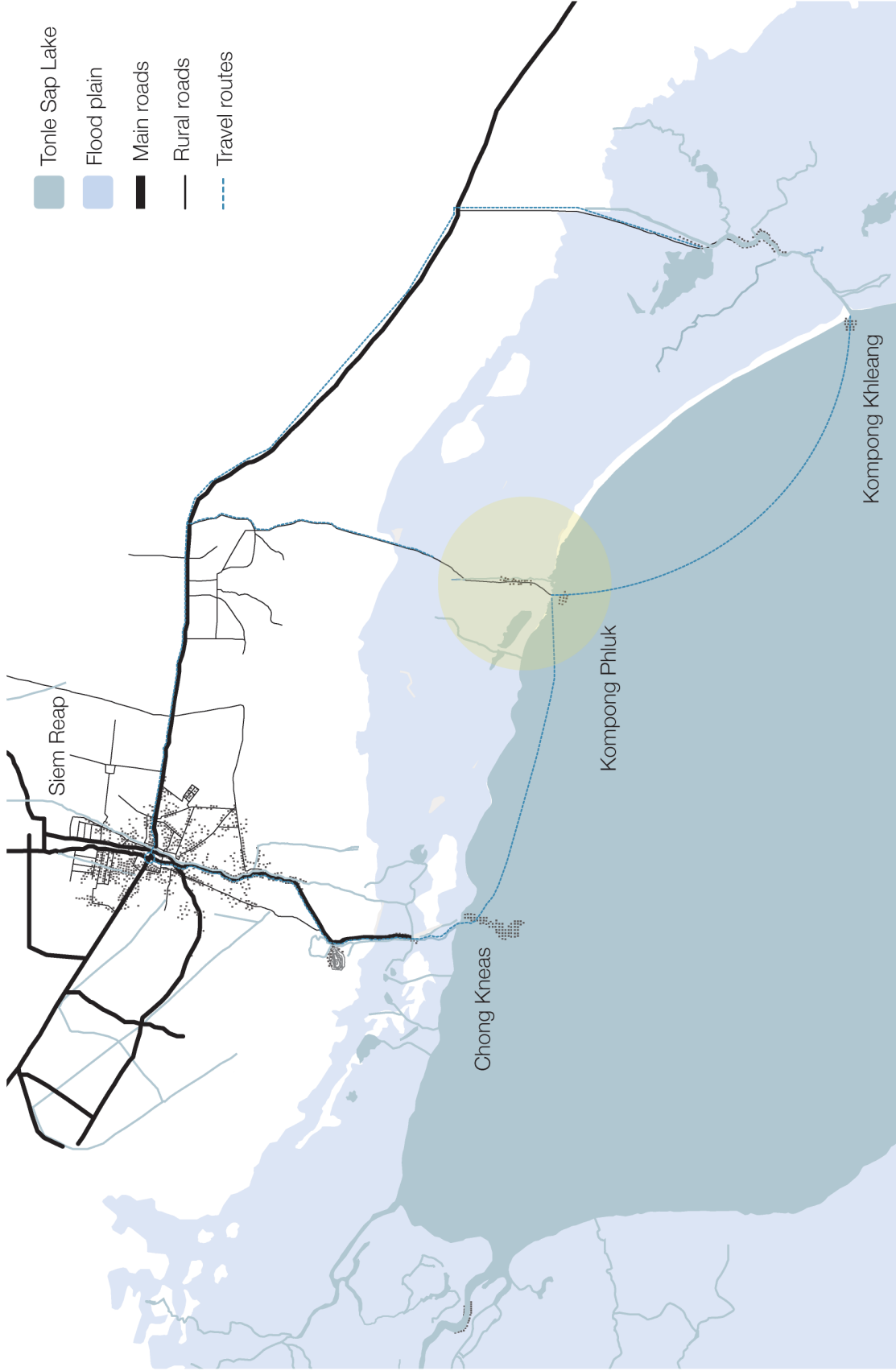



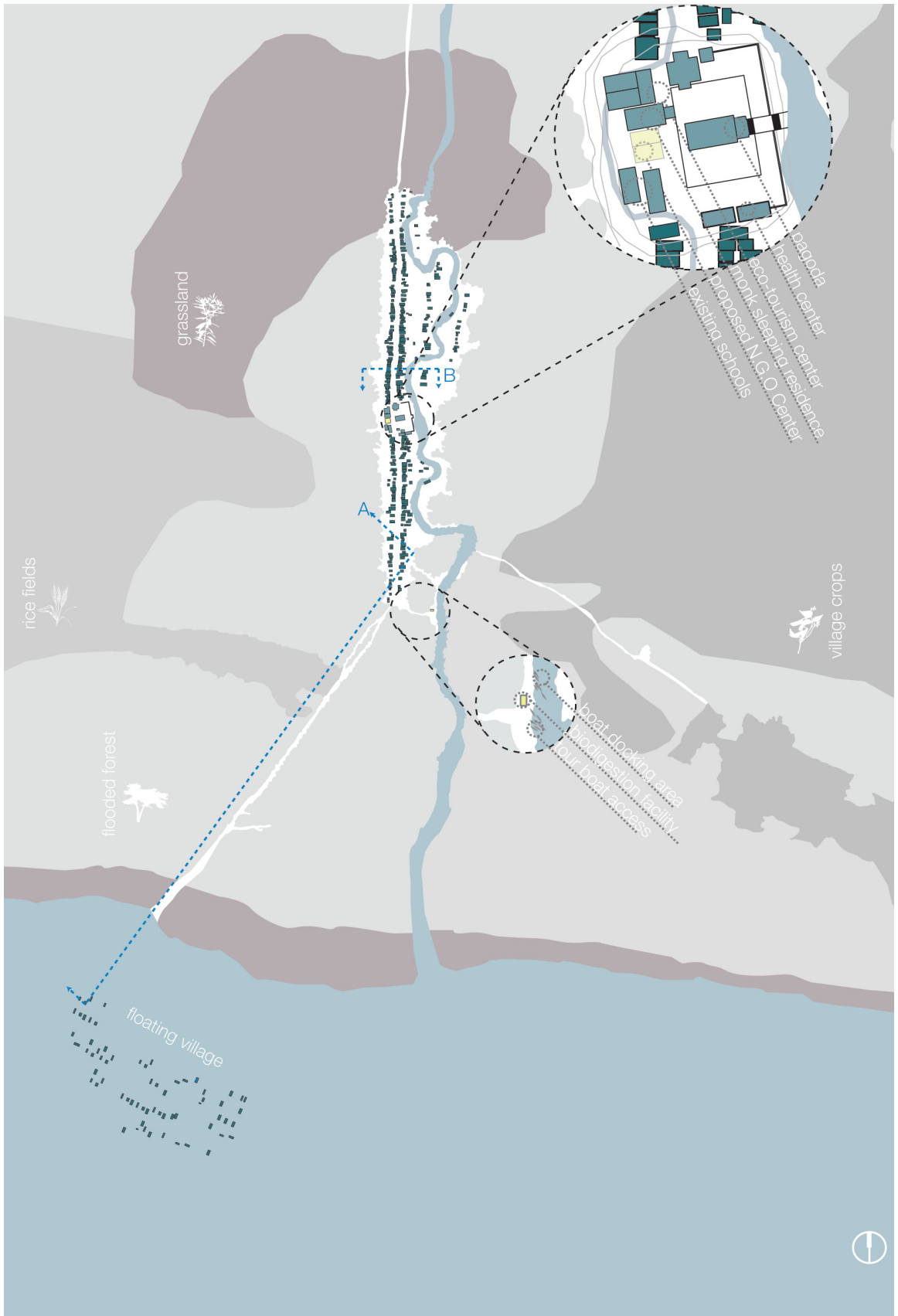

Site map of Kompong Phluk

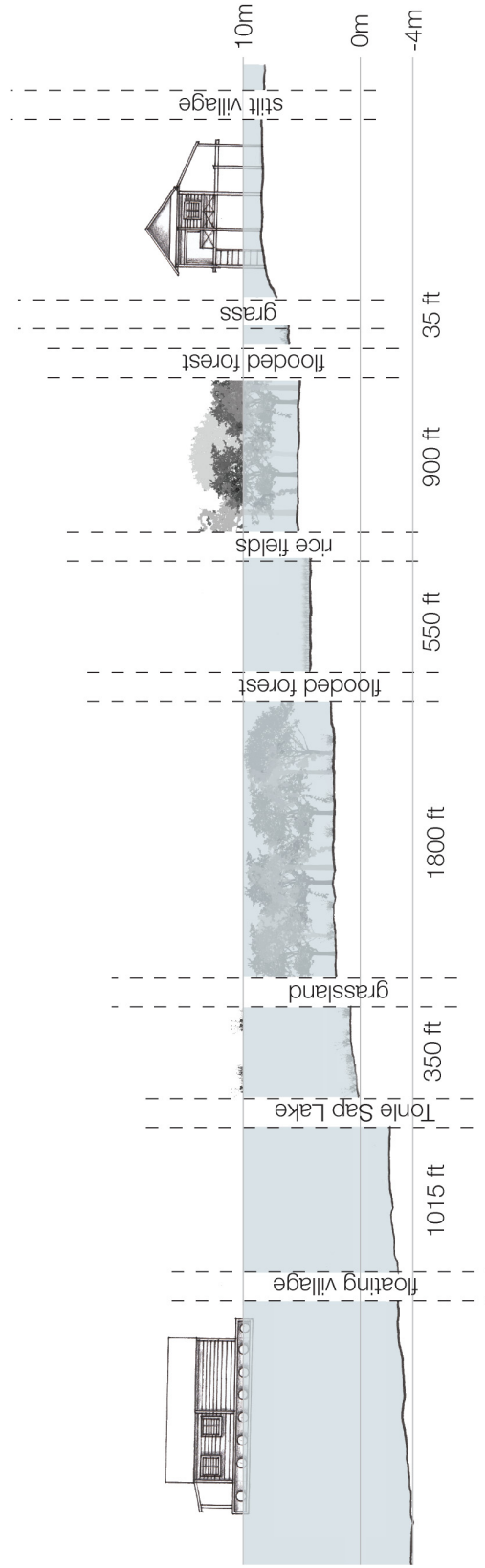
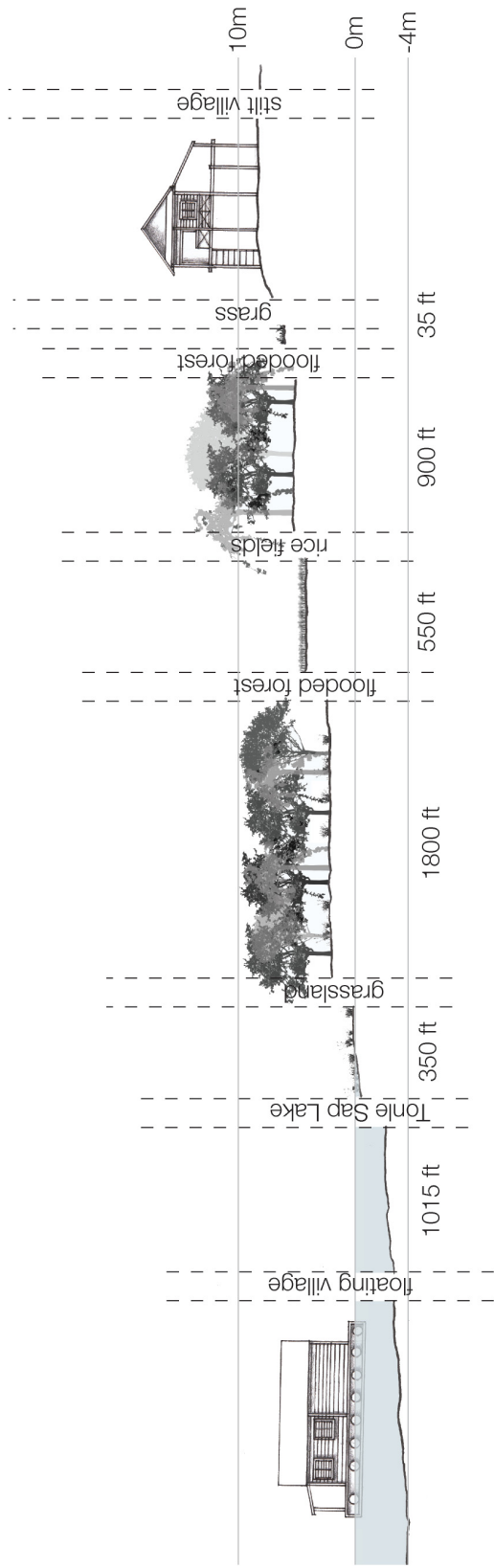

Section A: Longitudinal section of Kompong Phluk 12

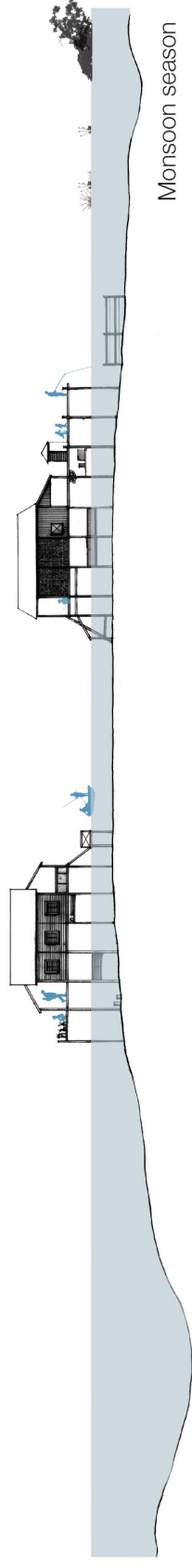
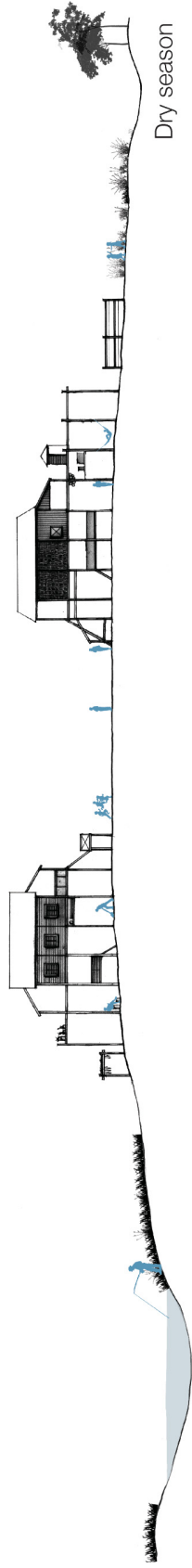

## EXISTING ARCHITECTURE

### The Vernacular

Bernard Rudofsky popularized the idea that vernacular buildings have as much to teach modern architecture as architecture does the vernacular. He believed that vernacular buildings “had an admirable talent for fitting their buildings into the natural surroundings. Instead of trying to ‘conquer’ nature, as we do, they welcome the vagaries of climate and the challenge of topography” (Rudofsky 1964, 4). Despite their classification as ‘traditional’ architecture, these vernacular environments respond and evolve according to shifting conditions in the environment, economy and social and cultural factors.

### Architecture of Kompong Phluk

In Kompong Phluk, like in all Tonle Sap Lake communities, architecture has evolved in response to the recurrent cycles of the annual flood and the availability of local materials. Its residents have adapted to fluctuating flood conditions by building their houses on wooden stilts to avoid damaging their main living quarters.

Kompong Phluk’s dependence on locally-sourced building materials has resulted in an overuse of these resources. The frequent replacement of these materials, due to decay from the extreme environmental conditions, has worsened this problem. Thatch roofed wooden dwellings are frequently destroyed by fire, which sparks easily in the dry season and, since houses are spaced so close together, one fire can

destroy large portions of a village.

Another common problem in the dwellings of Kompong Phluk is poor ventilation. Cost of electricity leads to the use of coal or wood fires for cooking and processing fish. This often occurs inside dwellings during the monsoon season, damaging health. A dependence on wood fuel also leads to “problems arising from wood collection, transportation and combustion” (Moeung 2001, 2). Therefore, an urgent need in the village is an alternative source of fuel that is affordable and available as well as improvements in the ventilation of dwellings.

Other problems in dwellings result from the adoption of modern technologies. Recently constructed public buildings use concrete stilts, which the locals have not been trained to construct or maintain. It is not an affordable solution for replacing wood piles in residential dwellings. In addition to this, metal roofs have replaced traditional thatch roofs that were naturally ventilated and locally made. Instead, the metal roofs attract the heat of the sun and trap it in the dwelling, creating a live-in oven. According to Schumacher, the “poverty of the poor makes it impossible for them to successfully adopt our technology. Of course, they often try to do so, and then have to bear the most dire consequences in terms of rural decay and intolerable social tensions” (Schumacher 1974, 145).



Street elevation of Kompong Phluk  
Photos taken by Barry Brown (Brown 2011)

## Case Study

### Stilt Houses of Kompong Phluk

#### *Structure*

A typical house in Kompong Phluk has a wooden structure consisting of circular 4-8" diameter posts spaced 6-8 feet apart to support the house up to 25 feet above ground level, depending on the maximum water height at that location. The structure extends 6-9 feet into the ground up to the roof. During the rainy season, this height protects the houses from flood damage. In dry season, it protects the residents in the home from animals on the ground, helps to ventilate the house and provides a shaded space for public interaction at grade.

#### *Materials*

All materials used for the construction of the house are locally grown or gathered and the building process makes use of simple tools and construction methods. The lack of roads into Kompong Phluk makes transport of non-local materials difficult and expensive, limiting their availability. Villages surrounding Tonle Sap Lake have adapted to this condition by relying on local forests to supply their building materials. The dwellings are typically clad with thatch or wood siding that is fabricated in removable 6-8 foot panels, which are connected to the structure through notching and wedging. Roofs are typically made of thatch or clad with corrugated metal sheets.

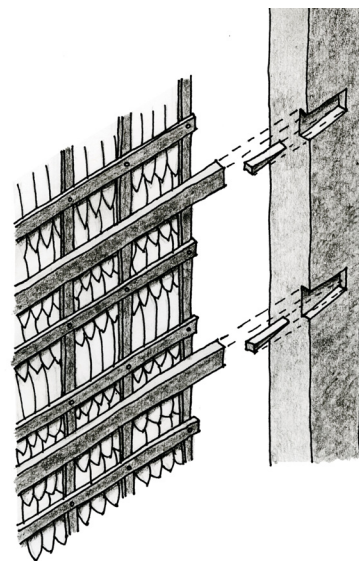

Cladding to structure connection



corrugated metal



corrugated metal



wood piles



clay tiles



wood siding



floating bamboo



reed thatch



bamboo grid thatch

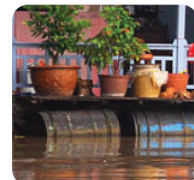

recycled oil drums



palm-leaf thatch



hung thatch



concrete stilts

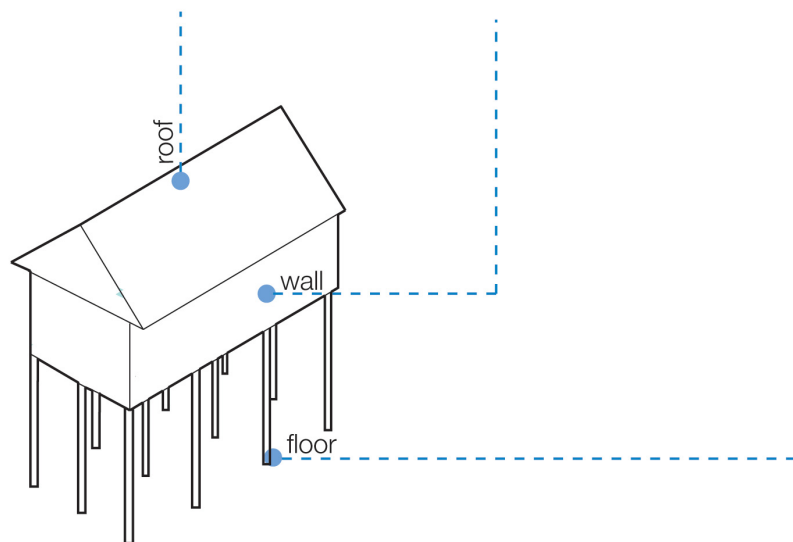

Material palette of Kompong Phluk





West Elevation

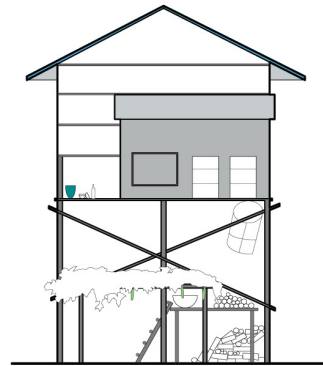

East Elevation

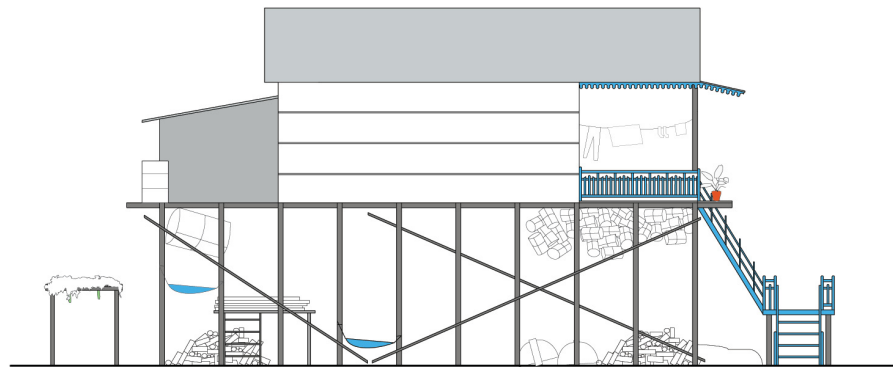

North Elevation

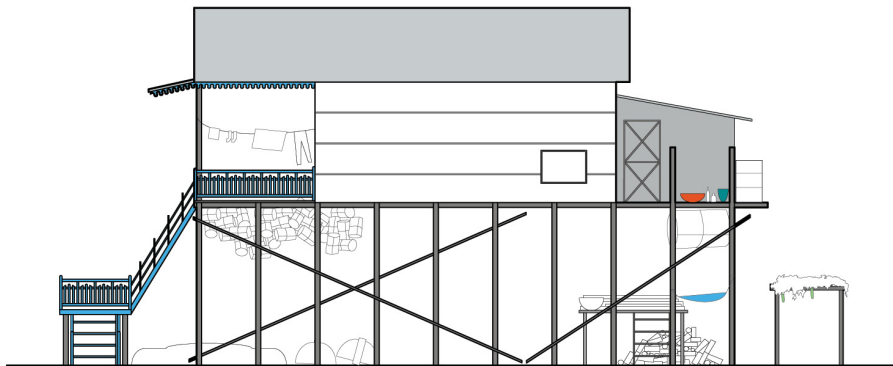

South Elevation

Stilt house elevations



Model of a stilt house in Kompong Phluk

### *Traditional Building Methods*

This traditional method of building developed over a long period. The wooden frameworks are notched and pegged to allow them to be disassembled completely from the top of the house downwards to salvage materials in the event of a fire. The disassembly also allows for easy replacement of parts as wooden posts deteriorate or cladding panels rot.

Structures in the village are typically built in phases for economy. For instance, villagers usually construct the stilts and the roof before they clad the floor or walls. Since most residents cannot afford to put on wall cladding right away, the house is clad in thatch until the family can afford wood or corrugated metal cladding. Common practice is to clad only the street facing facade of the house to ensure looking 'similar' to the surrounding neighborhood. The remaining walls get clad in low-cost thatch or are just left open.

### *Interior Organization*

The family sleeps on the elevated level of the dwelling. This is an open plan with cloth partitions separating the different sleeping areas: the parents to either side of the main entrance, the boys on the rear left and the girls on the rear right. The kitchen is usually a separate structure, down a few steps from the main living area. The main living and working space is outdoors under the house. Here, the family spends their days during the dry season. People rest in hammocks during the day or place their children in them as they work. Hammocks have become so engrained in the culture

that they are even used as beds inside the house. In the monsoon season, the family moves their outdoor activities up to the main level on large outdoor patios or porches.

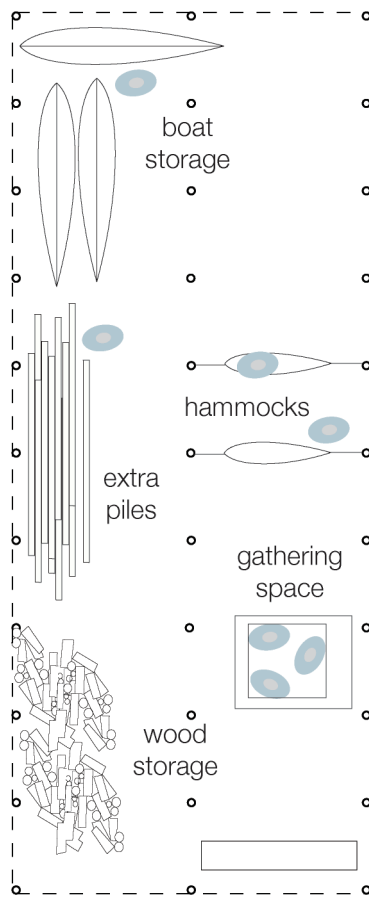

Ground level

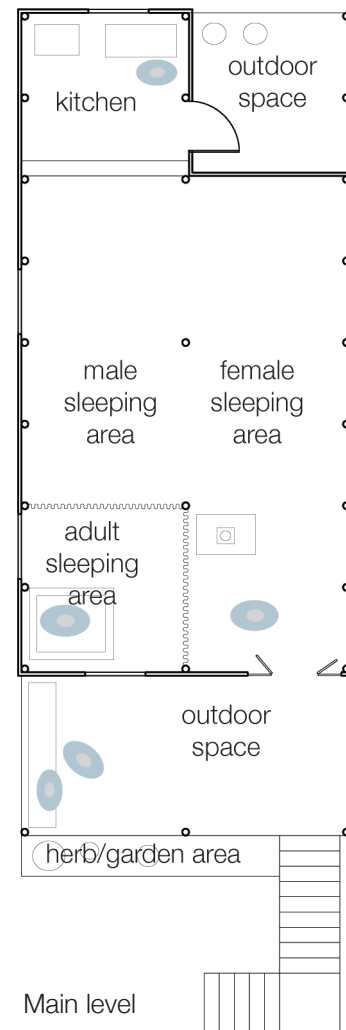

Main level

Organization of a stilt house

### *Climatic Adaptation Strategies*

Stilt houses have good natural ventilation strategies for passive cooling. Primarily, the house is cooled by the air that passes underneath it and is drawn up into the space. To aid this natural ventilation, the floor is made of widely spaced bamboo slats. The house also promotes cross-ventilation through a large gap between the wall and roof cladding. This allows warm air to flow out of the house, and forces air to pass through the space from one wall to the other.

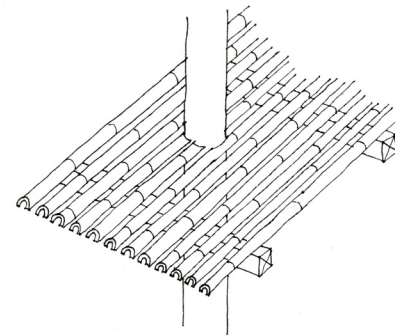

Bamboo slat floor

### *Sanitation*

Tonle Sap Lake suffers from a severely inadequate waste management system and a lack of education about the consequences of poor sanitation practices. For most residents, the toilet is a hole in the floorboards that allows them to defecate directly into the lake for the 9 months of monsoon season. Every day, 77 tons of feces enters the lake; this is the same water that the residents use to bathe, drink, fish and play (WSP 2008, 17). A further source of pollution is waste from animal husbandry and fish farms (47% of people in Kompong Phluk raise animals as a source of income, primarily fish farms and pigs) (Marschke 2005, 91).

Access to clean water is a problem for residents of the Tonle Sap. Only 20% of Cambodia's rural population is served by a public piped water supply (ADB 2004, 6). While there are tube wells in most of these stilt villages, 68% of households in the Tonle Sap still use Tonle Sap as their primary source of drinking water (Marschke 2005, 90).

## ENVIRONMENTAL EDUCATION

### Education as a Development Strategy

A central strategy for successful rural development is education. Education is necessary for expanding skills required for obtaining employment, securing food supply, and sustainable development. The Food and Agricultural Organization of the United Nations has been committed to developing rural populations through education. They implemented the Education for Rural People (E.R.P.) policy that aims at providing education to the 800 million illiterate people of the world. They see education as one of the key assets that will enable households to escape poverty and to secure food for a rising population (Acker 2009).

The Bruntland Report first publicized and strengthened the idea that education of the rural population should emphasize environmental education rather than book learning from western countries. They argued it was impossible to separate economic development issues from environmental issues because “development cannot subsist upon a deteriorating environmental resource base” (Bruntland Report 1987, 32). Poverty forces people to “overuse environmental resources to survive and environmental degradation further impoverishes them, making survival even more difficult and uncertain” (Bruntland Report 1987, 32). Therefore, management skills need to become a core component of education strategies, since the majority of rural employment is involved in the use of natural resources.

There is also a need for sustainable training strategies so people in a village continue teaching after international aid leaves. Schumacher hints at these ideas when he suggests that villagers need to be included in the process of planning, building and sustaining their own solutions. If this happens, “not only would a given project have been completed but a whole community would have been set on the path of development” (Schumacher 1974, 173).

### **Building Program**

The program is an N.G.O.- supported education exchange center to foster local-to-local transfer of knowledge regarding sustainable use of resources, environmental management strategies and the development of new skills to diversify livelihoods on Tonle Sap Lake. The Center is located in the village of Kompong Phluk and it aims to spread the resource management strategies that are taking place in this commune to the other 80 communities surrounding the lake. This center will unite these communities who have up until now, primarily been connected by their dependence on the rapidly depleting fish stocks of the lake. It will provide them with opportunities to diversify their livelihoods through the sharing of various skills and knowledge that already exist in this area. It will also aid them in sustaining the resources (forest and fish) that are providing their primary source of income.

The main space of the center acts as both a gathering space and a working space, where proper fishing practices, fish processing, and the making of traditional

crafts are being practiced and thereby passed on to those who are visiting the center. The activities going on within this space all promote the sustainable use of resources, as does the building that is sheltering them.

The locals from other villages who are visiting the Center can take these lessons and strategies back to their own communities, creating a network of change that spreads across the lake. As a way to make possible this local-to-local interaction, the center will include sleeping huts to host people from away. It also offers support through group discussions and micro-financing as an option for families to escape the debt that keeps more than 80% of them in poverty. In addition to hosting local people, this center will also host international researchers who are studying the lake. This international-to-local interaction will be a mutual benefit where the locals can teach scholars about the lake, and scholars can aid the community both economically and in the transfer of new skills and ideas.

The Center will be initiated and supported by an N.G.O. and therefore will contain offices to have private meetings and for compiling written documents. These documents will help the Resource Management Committee implement their strategies at a government level. The Center will have adequate sanitation facilities including toilets, access to clean water and electricity. These sanitary living strategies will foster proper health practices in the future.

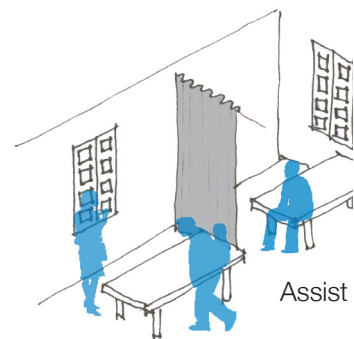
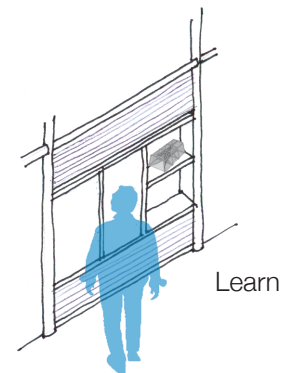
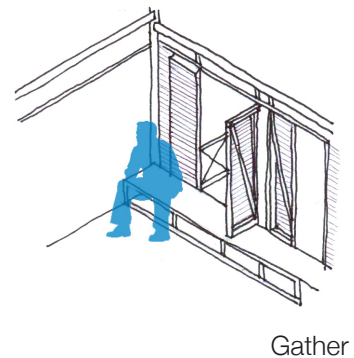
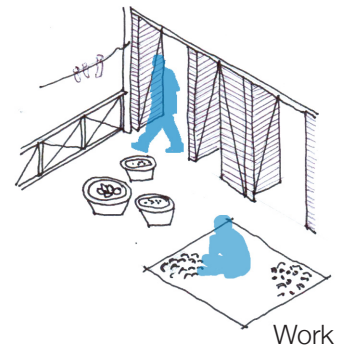

Program spaces





Program activities

## User Groups

The primary people using this facility will be Cambodian fishermen and their wives. The men are typically responsible for catching the fish, while the women processing them (smoking and drying) transport them to market, as well as their domestic activities of collecting daily supply of water and taking care of children and elderly family members. These are the people that will be learning and teaching in the facility.

N.G.O. workers will also use the Center as a satellite office for projects around Tonle Sap Lake. They will provide support to the facility and its users and be the main facilitator between the Resource Management Committee and district/government officials.

Occasional 'users' will include tourists and international researchers. Tourists visiting the lake communities will be able to enter the facility to learn about the way of life of the lake and to observe and take part in the making of traditional craft. International researchers who are studying the biosphere reserve can also use this center as an on-site office.

## CHAPTER 2: DESIGN

Umberto Eco looked at issues of designing new buildings in traditional societies. He suggested that designing in a vernacular society should “create an architecture that is ‘new’ but that answers to the basic code which governs a particular society” (Mann 1985, 14). Rather than building a foreign object in a traditional setting or conforming completely to a local vernacular, this approach “produces an architecture that would be understood and accepted because its basis exists within the framework of social and aesthetic expectations. At the same time, this architecture would anticipate cultural, technological and economic changes” (Mann 1985, 14).

The thesis design employs this approach to create ‘new’ architecture in the form of an Education Center in Kompong Phluk. It focuses on the preservation of local culture and traditions while also encouraging change through social and economic development. The main design objective is to develop a building that is sensitive to its context including; local cultural practices, surrounding architecture, and climate through a careful study of local customs, construction methods and inhabitation patterns.

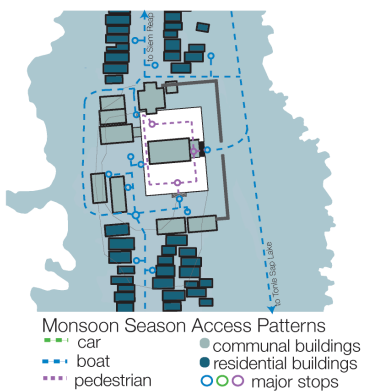
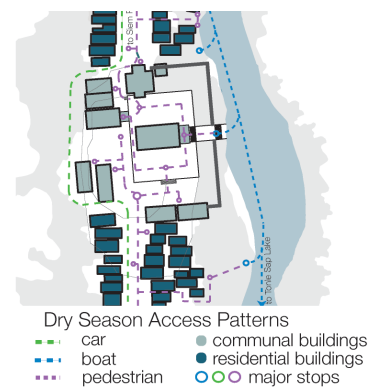
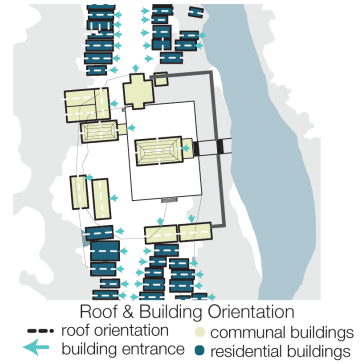

Site analysis

## PHASE 1 EDUCATION CENTER

### Site Strategy

The building is sited in the center of Kompong Phluk, adjacent to all the other communal buildings in the commune. It sits between two schools and an old pagoda that is now used as a sleeping residence for the village monks. By being located here, the Environmental Education Center can share facilities with the schools and promote the integration of environmental learning and skill development into the school's curriculum.

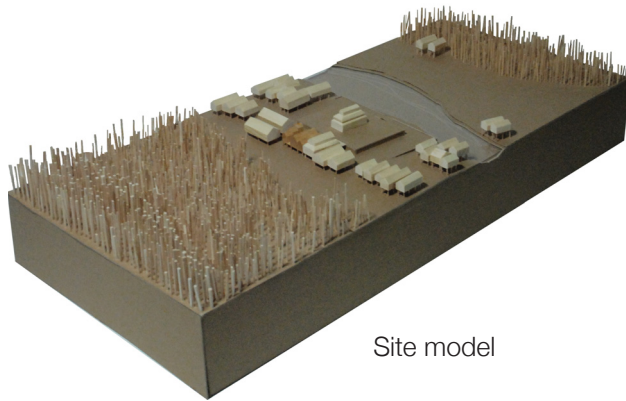

Site model

The building's primary site strategy is to respect the 'rules' structuring the local vernacular. These include street condition, height of surrounding buildings, typical building size, roof orientation and village access patterns. It also aims to maximize the site's usage in both seasons, through the creation of an elevated outdoor space that replaces the 'main street' when the village street is covered in water.

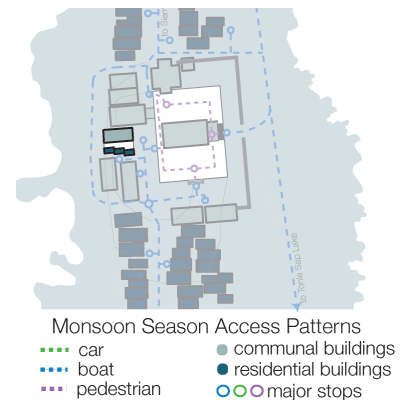
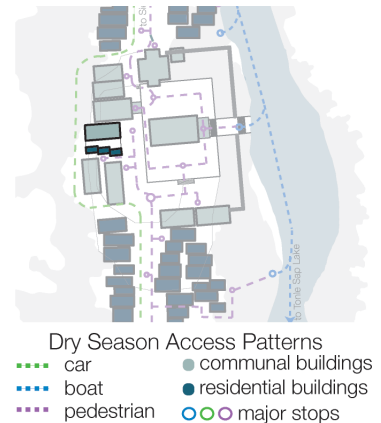
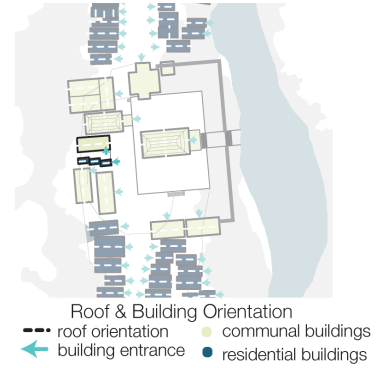

Building parameters

## Evolution

The design evolved from the fusion of two building types identified in the village of Kompong Phluk: the residential type (a typical stilt house) and the public type (existing schools). Interpreted as the Education Center and the sleeping pods, these two types interact through a raised street that forms an outdoor gathering space from May-October when the village street is covered in water. This space becomes the only substantial public space in the village during the monsoon season and is the largest shaded space in the dry months.

A second design consideration is the Center's ability to evolve and expand over time. As with other structures in the village, the Center will need to expand its program as more funding becomes available, or when the need for more program arises. For this reason, the spaces in the Center have been arranged so the building can easily be extended, while functioning as a whole at each stage of development.

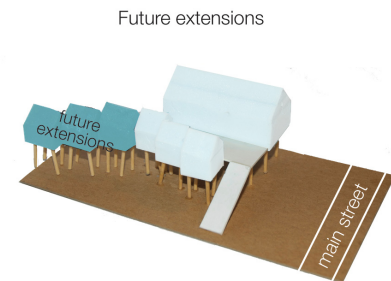
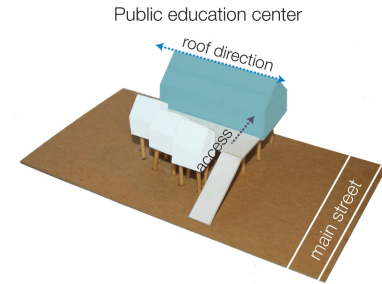

Design concept

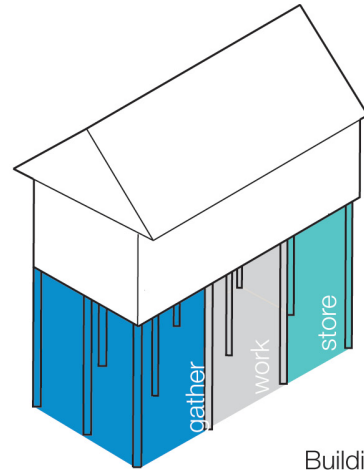
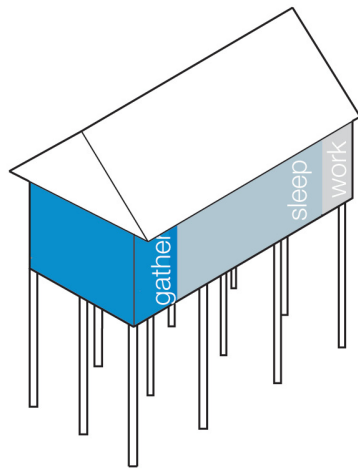

Building zoning

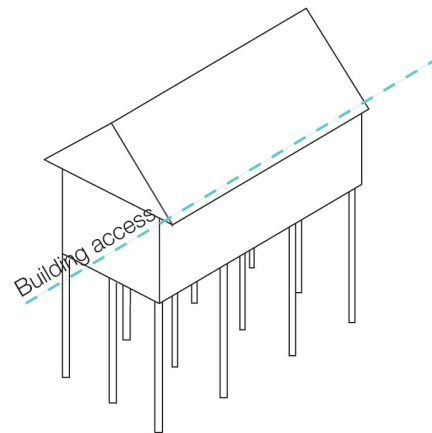
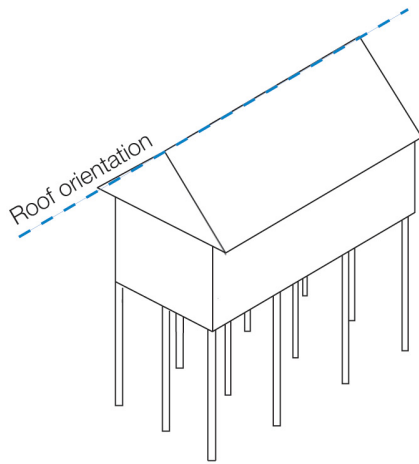

Formal characteristics

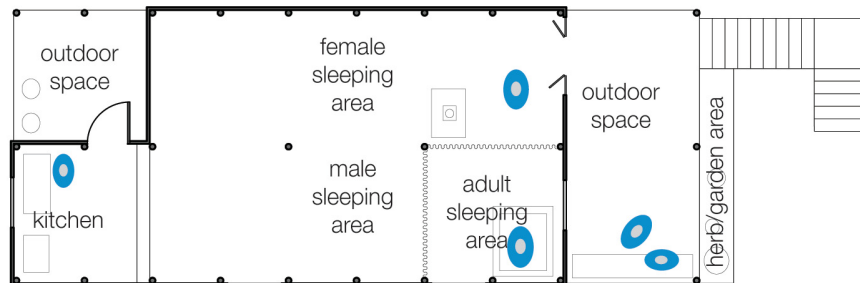

Interior organization

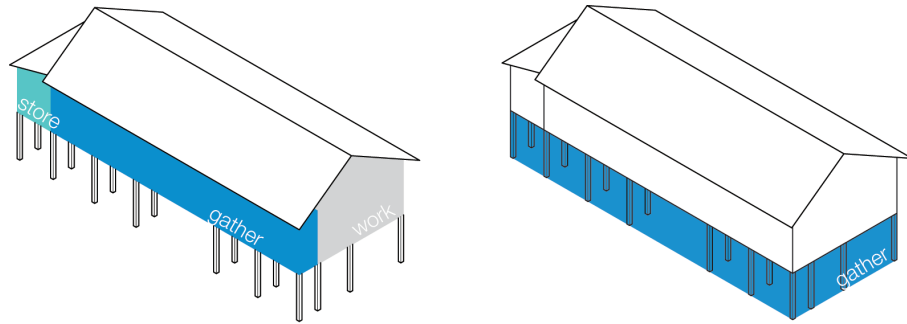

Building zoning

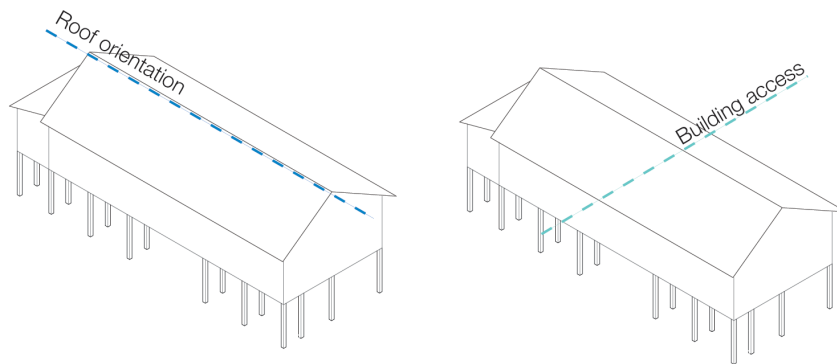

Formal characteristics

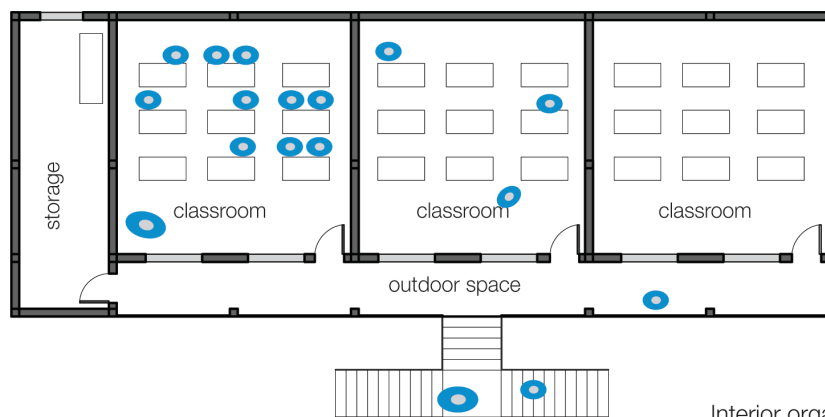

Interior organization



- 1 Delivery Entrance
- 2 Office
- 3 Display/Gather Area
- 4 Outdoor Work Area
- 5 4 person dwelling
- 6 2 person dwelling
- 7 Entrance from street
- 8 Floating ramp
- 9 Water Collection
- 10 Kitchen
- 11 Toilet
- 12 Storage

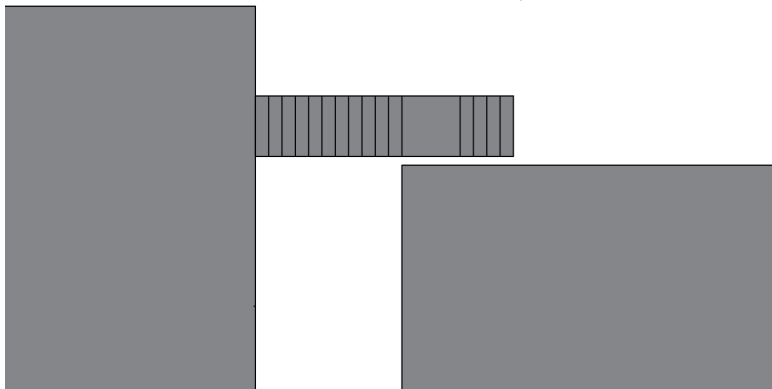

Main floor plan



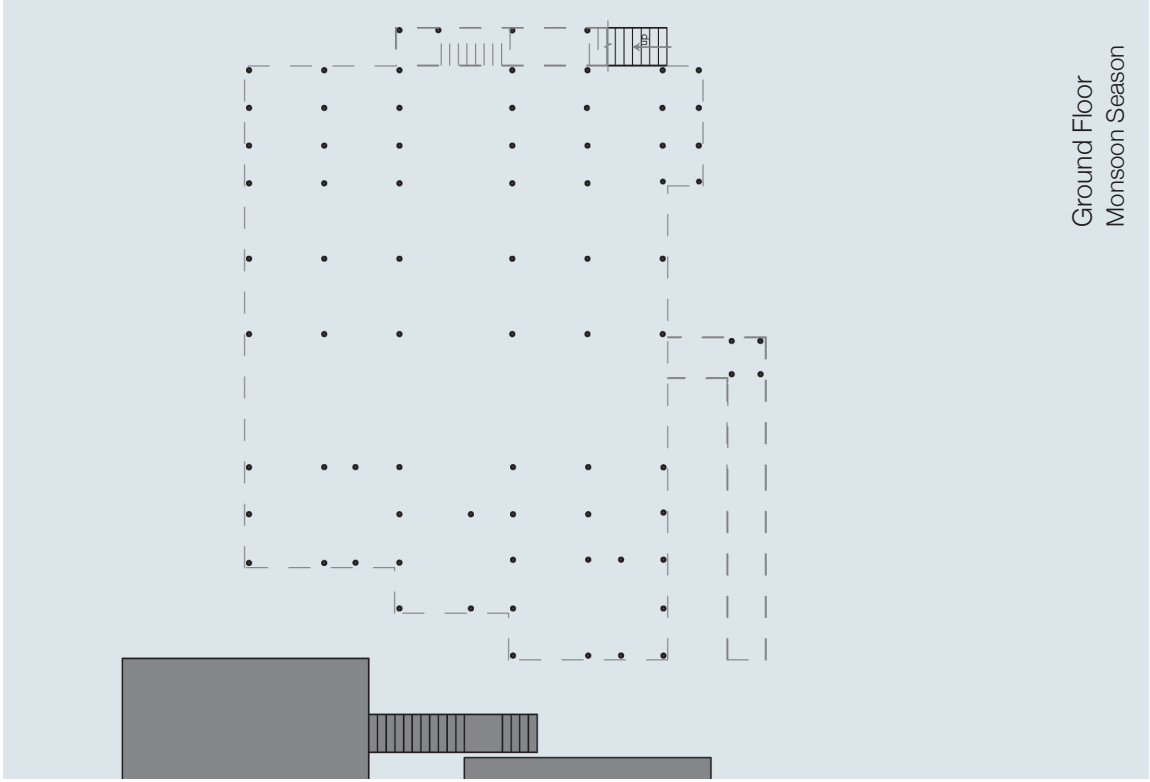

Ground Floor  
Monsoon Season

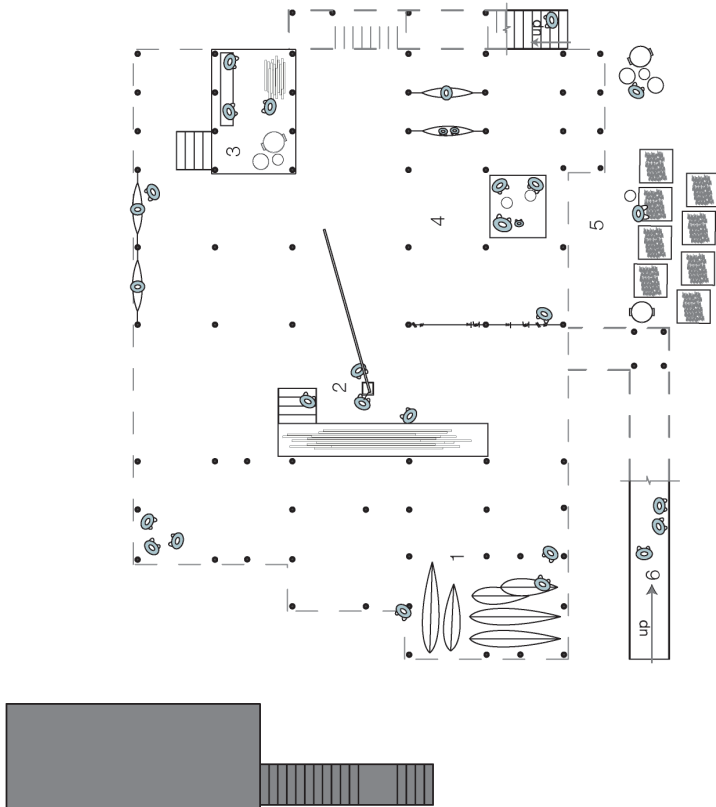

Ground Floor  
Dry Season

- 1 - Boat storage area
- 2 - Wood preservation station
- 3 - Raised platform for drying
- 4 - Gathering Area
- 5 - Fish Processing Area
- 6 - Floating Ramp

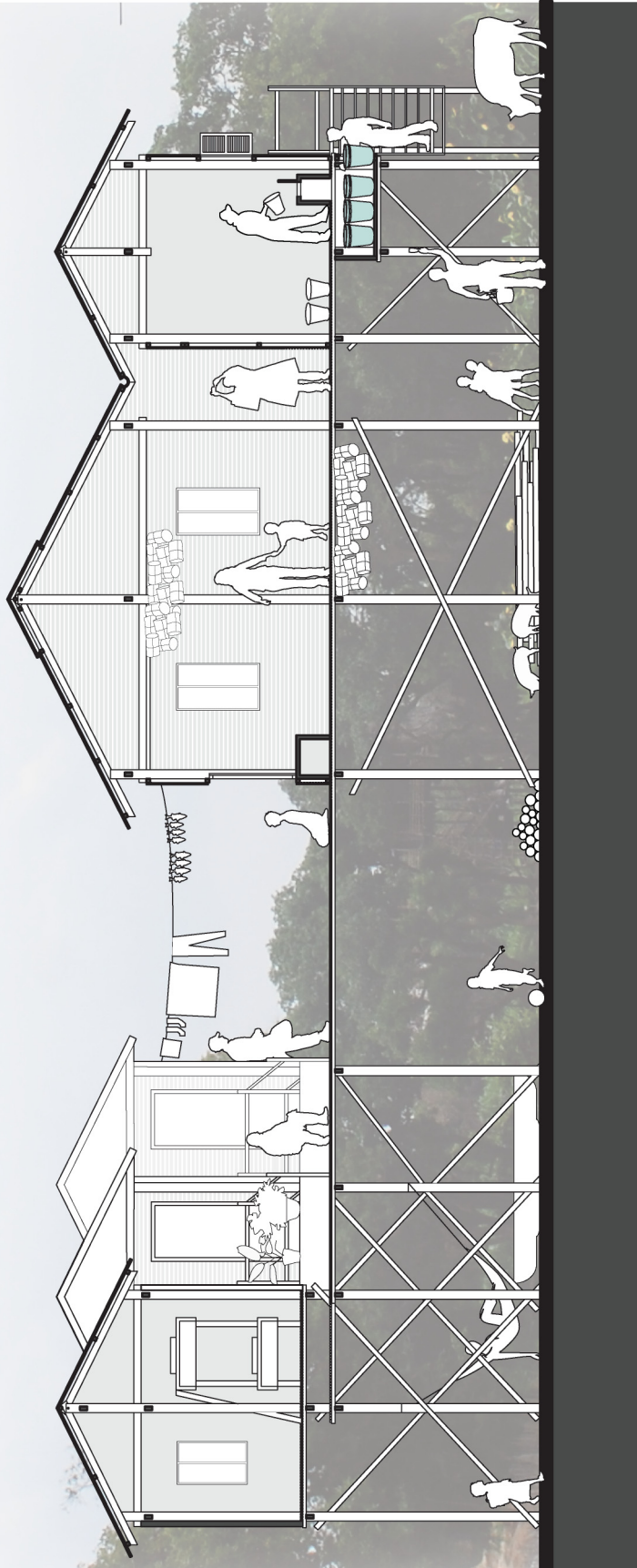

Dry season section

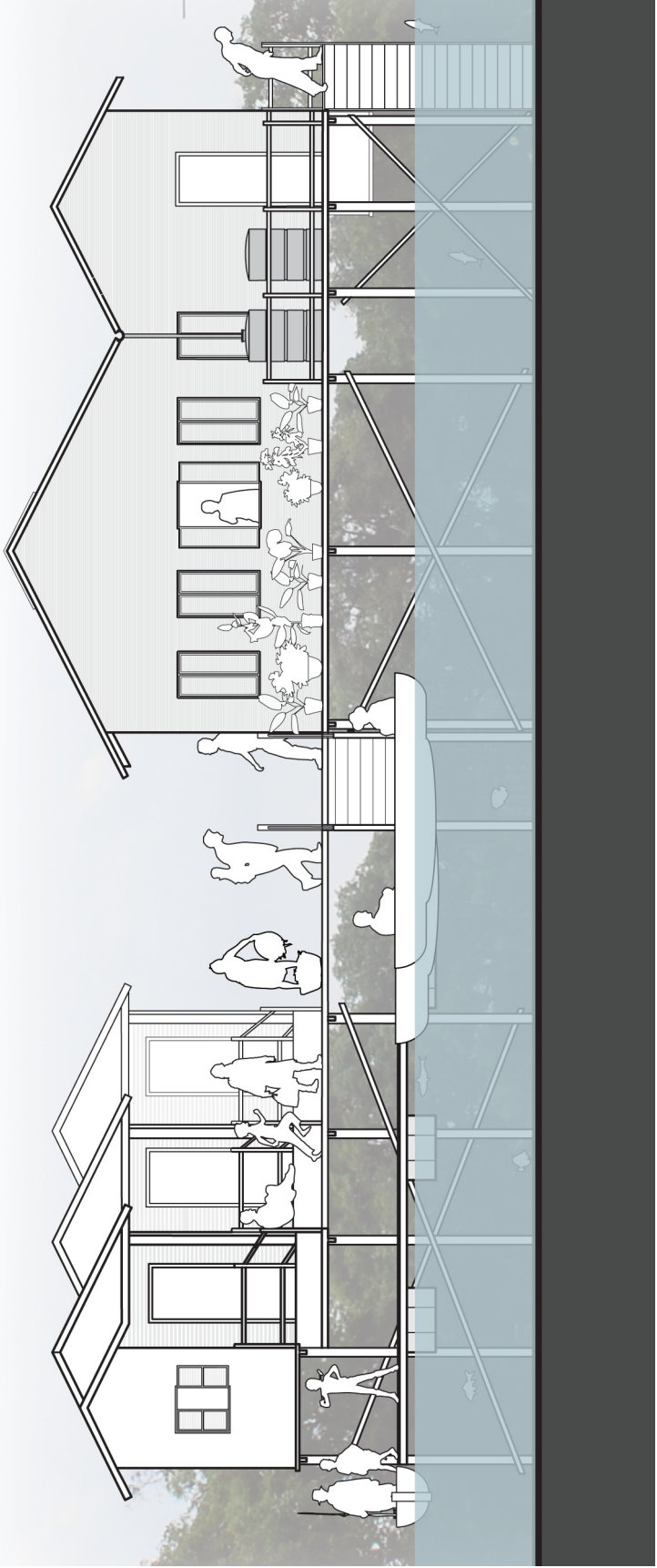

Monsoon season elevation

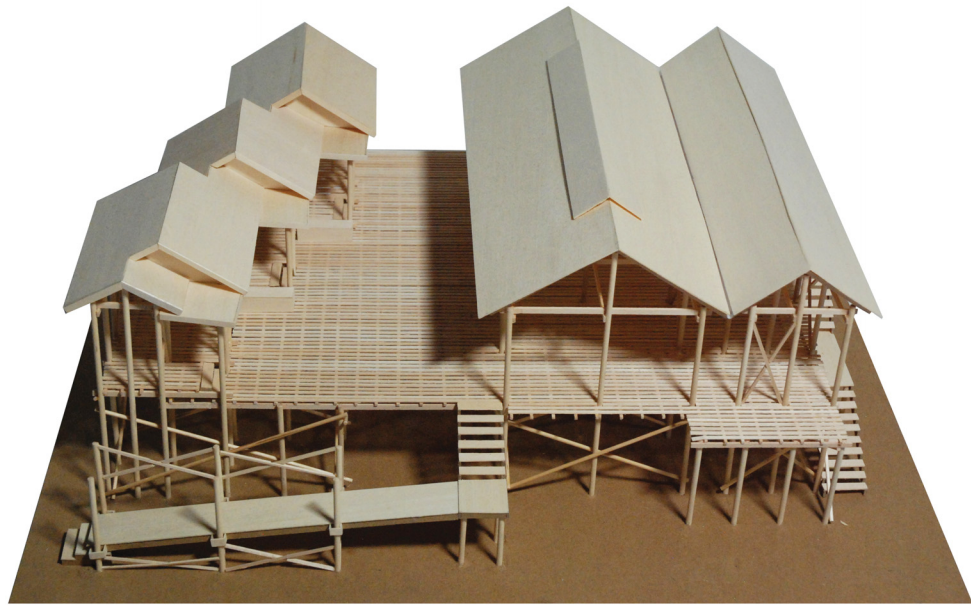

Framing model

## Building Systems

The building itself is an interactive educational tool where sustainable construction and sustainable systems (such as water collection, waste management and passive ventilation) offer the residents examples of sustainable use and management of resources that are largely familiar, affordable and easy to operate. These systems can be scaled down and adopted at the scale of the dwelling to improve quality of living in the village.

### *Wood Preservation*

The Center is built with wood stilts like all other houses in the village. To protect the stilts from decay and frequent replacement, they will be preserved with a boron-salt preservative.

Boron is a natural mineral that will not harm the fish or plant-life that the commune depends on for their livelihoods. By using circular wood for the stilts (keeping the trees intact), the vertical vessels in the tree that absorb food and water are preserved. Cutting off the end of the wood in the solution exposes these vessels to absorb the solution, which is highly soluble and therefore diffuses rapidly, coating the entire outside perimeter of the cross-section. As the wood dries, water moves out of the tree, leaving the solution behind. Upon dehydration, the salt renders the tree water insoluble to prevent the preservative from leaching out upon future wetting (Caldeira 2010, 188).

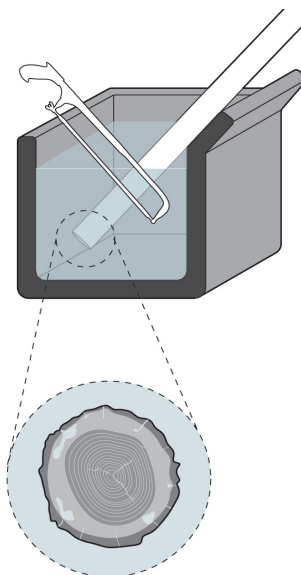

End of tree gets cut off in boron-salt solution. The vertical vessels in the tree absorb the solution and diffuse it through the active perimeter of the tree.

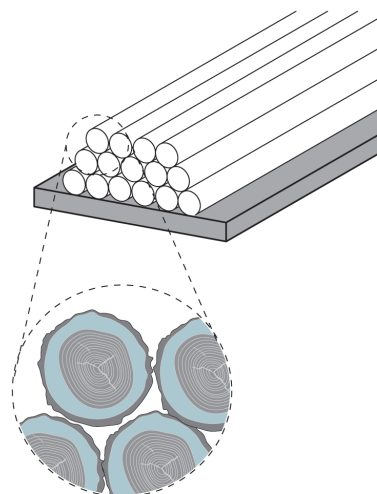

Wood gets stacked to dry for 1-2 days. Boron-salt solution is now completely coating the outside perimeter of the tree and stays in the wood as the water dries out.

Wood preservation process

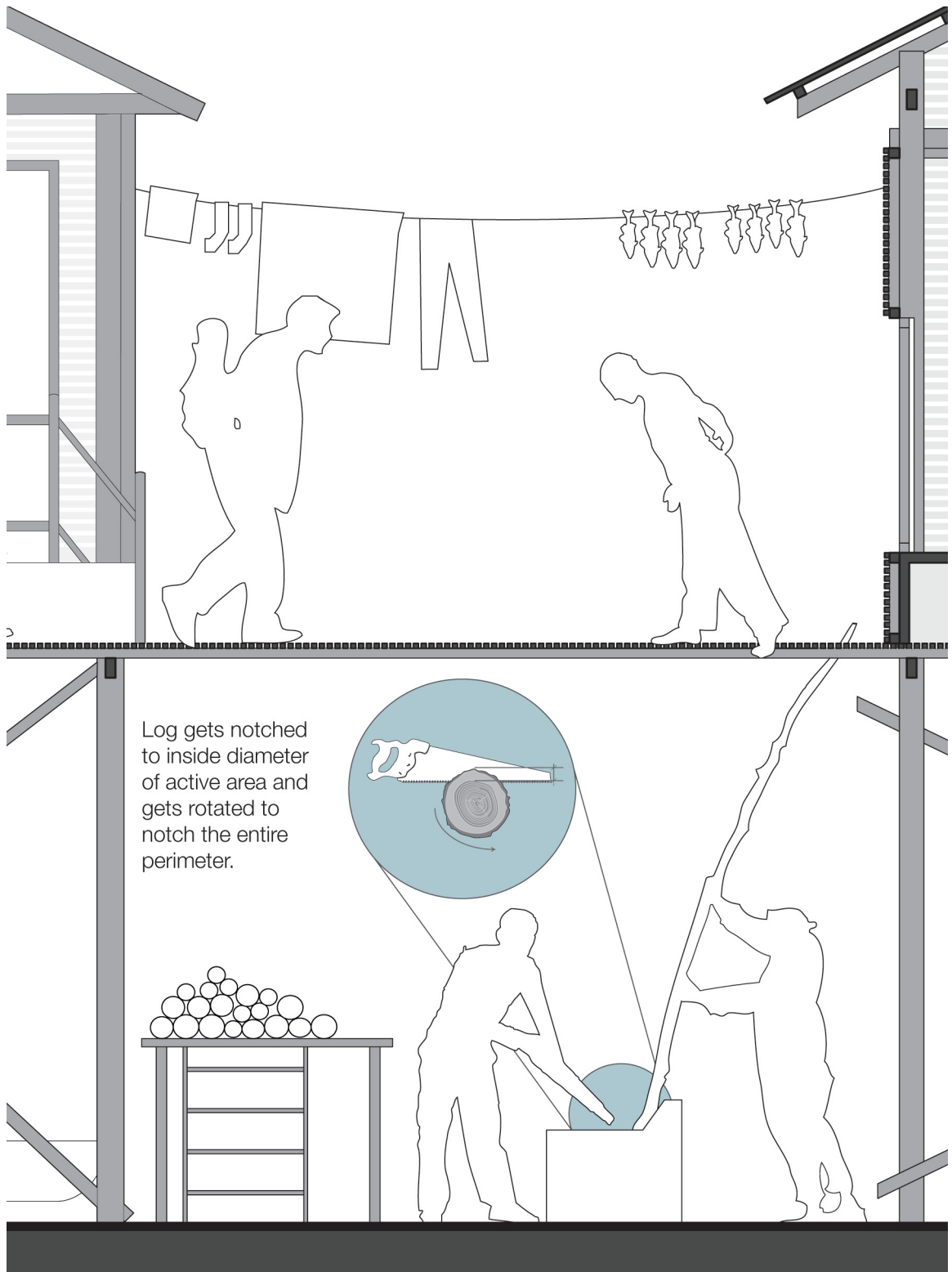

Log gets notched to inside diameter of active area and gets rotated to notch the entire perimeter.

Boron-salt preservation process

### *Ventilation*

The residents of stilt houses have established an efficient and effective system for passively ventilating the house. Air flowing underneath the house gets cooled by water during the monsoon season and then flows up into the house through widely spaced bamboo slats. The warm air flows out of the house through a gap between the wall and roof cladding.

The Center uses this system of passive ventilation and also improves it by drawing out the warm air that is gathering at the roof peak (the hottest air in the house). This is accomplished by creating a secondary roof structure at the top of the peak which creates a small gap between the primary and secondary roof. Air is drawn out through this gap which also permits diffused light into the building. The Center also improves ventilation by proposing a permeable cladding that uses woven fishing traps to replace the corrugated metal sheets that are typically used as cladding panels in the village. This permeable cladding promotes cross-ventilation, pulling air through the slats from one side of the Center to the other.

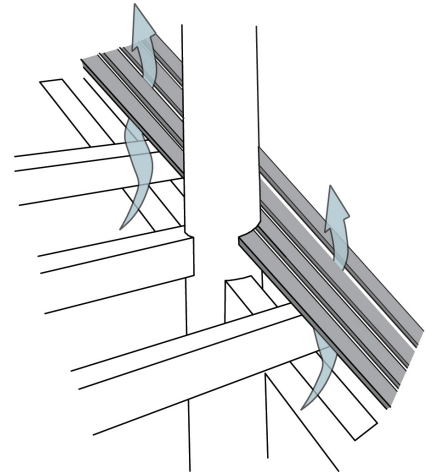

Air flow through bamboo floor

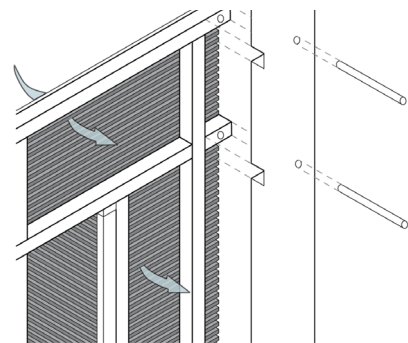

Air flow through permeable cladding

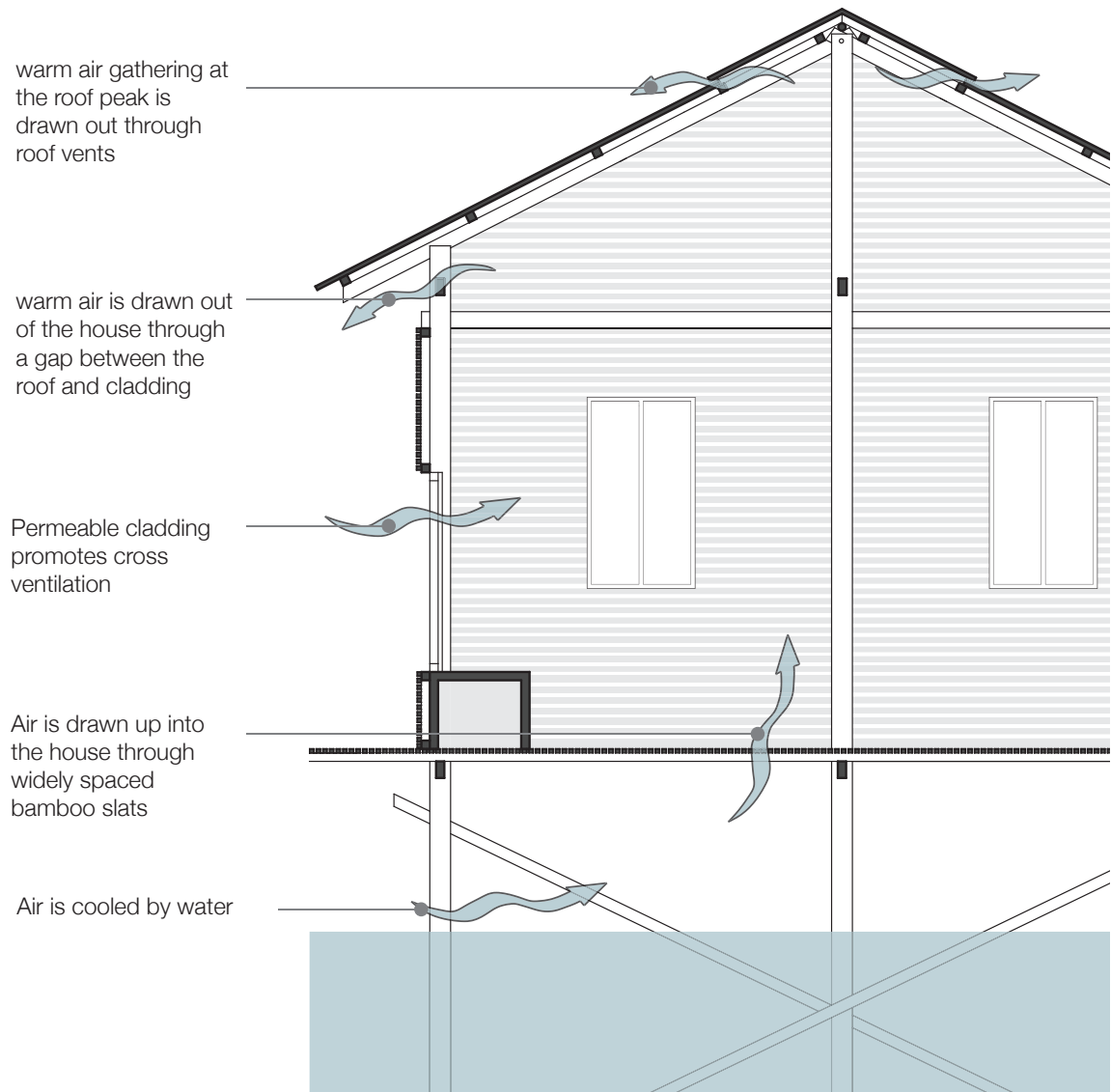

Ventilation of education center



### *Water Sanitation*

Unsanitary water from the Tonle Sap is still a main source of drinking water because it is easy to obtain and available at no cost. The Center collects rainwater as a way to introduce domestic rainwater harvesting to the village, providing an affordable solution for meeting local water needs without the burden of water carrying (Thomas 2007, 8).

Rainwater, in general, is of excellent quality with very little contamination (Thomas 2007, 36). Any contamination of the rainwater by roof substances will be destroyed through water boiling using methane powered burners inside the Center. The water can then be distributed to community members at minimal cost or used for hand washing in the Center.

For storing water, the Center uses a latex concrete tank, which is economical, durable, fire-resistant and easy to construct and repair (Knott 2005, 116). This tank was chosen because it has a high percentage of labor cost which will generate local employment and put money into the local economy (Thomas 2007, 36). The material, which consists of latex, fabric and a very thin layer of concrete, can also be used to construct the gutter and downspout. It can also be used as a future substitute material for corrugated metal roofing and cladding.

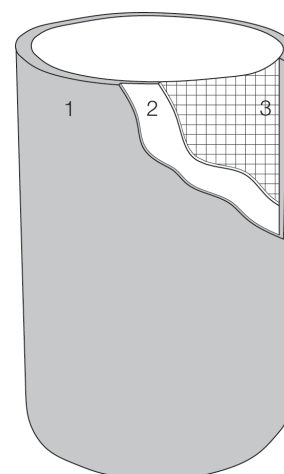

- 1 Latex slurry
- 2 Several layers of fabric
- 3 Formwork

Tank construction

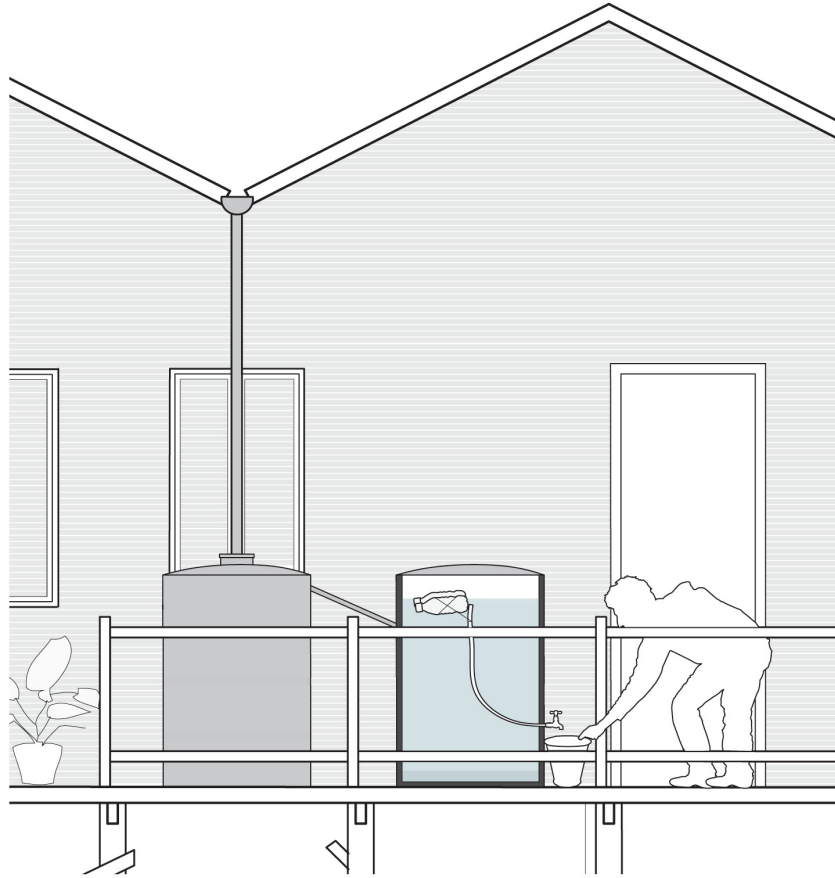

Rainwater collection

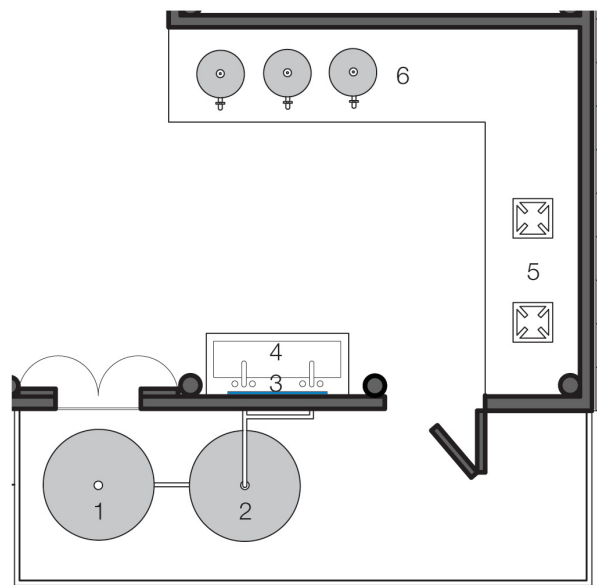

- 1 Rainwater Collection Tank
- 2 Overflow Tank
- 3 Display Panel
- 4 Double Sink
- 5 Water Boiling Station
- 6 Water Distribution Tanks

Water sanitation area

## Cladding

The Center introduces two new types of cladding that can provide substitutes for the corrugated metal cladding used in the village. Both proposals are designed to be easily attached and detached to the structure to resemble traditional cladding panels.

The first cladding proposal uses common Cambodian fishing traps (woven bamboo mats) that are tied or mechanically fastened to a wooden framework and then pegged into the notched structure. The small gaps in the fishing traps allow air to pass through the wall, ventilating the space.

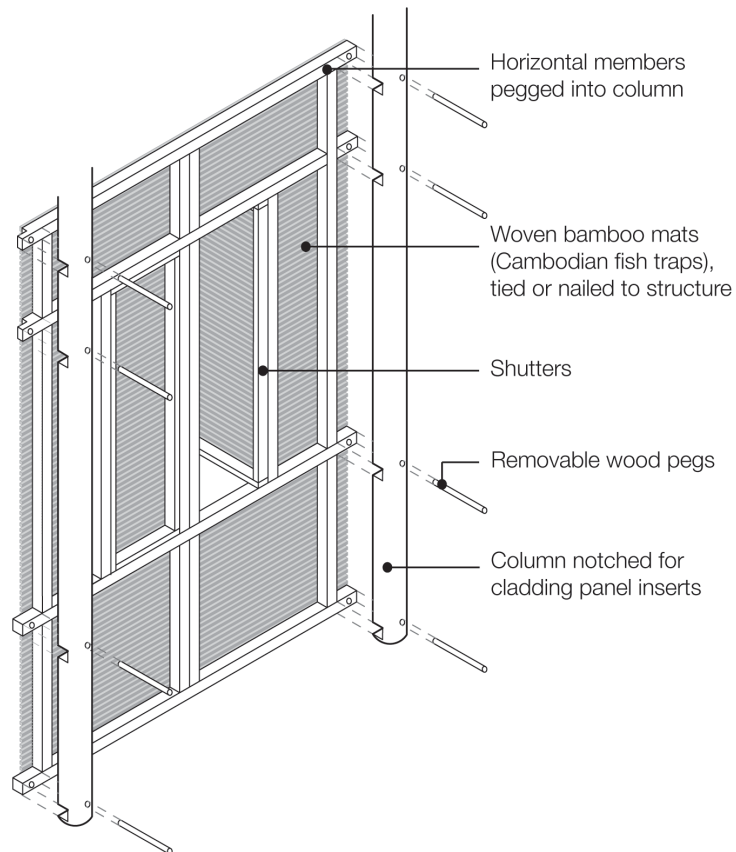

Proposed cladding 1  
Re-purposed fishing traps

The second cladding proposal introduces a more 'modern' type of cladding that sheds water by using overlapping recycled aluminum cans. This proposal provides a use for the cans that are polluting the lake and is resistant to the rust that deteriorates metal cladding. The cladding is simple to assemble, and if adopted by residents, would create a new employment opportunity in the village.

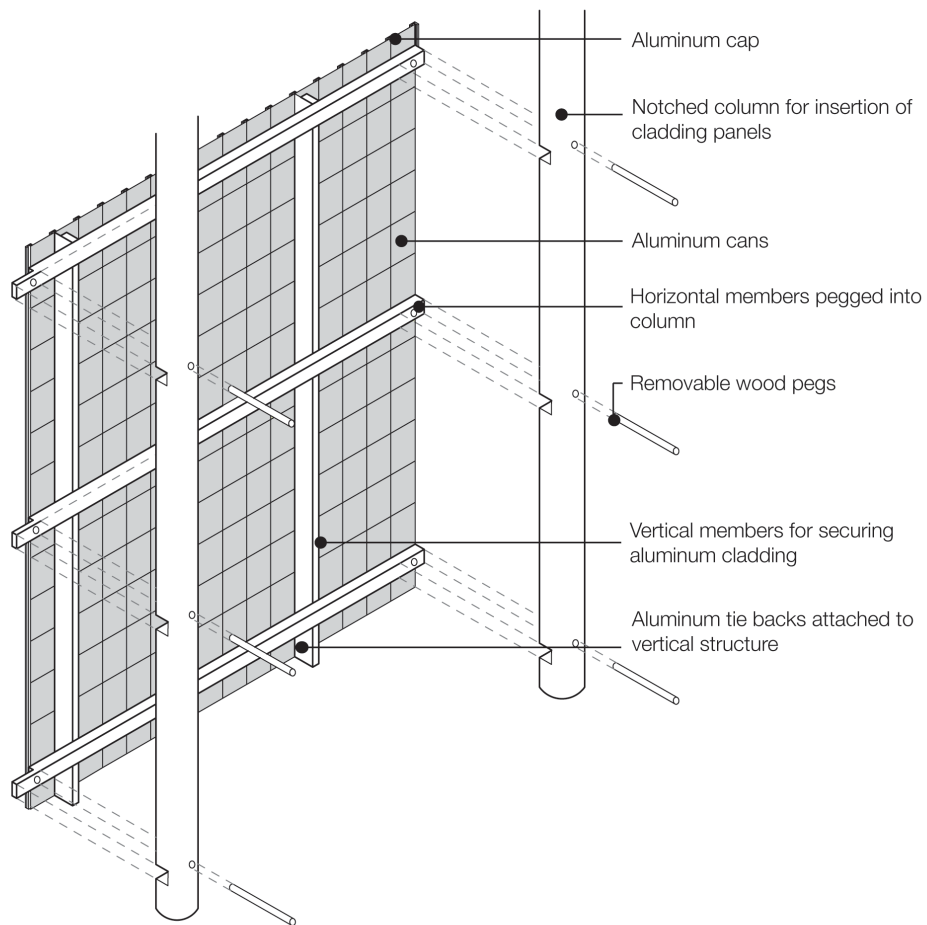

Proposed cladding 2  
Recycled aluminum cans

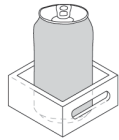

1 Place can in wooden holder

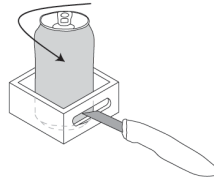

2 Rotate can on blade to cut top and bottom off

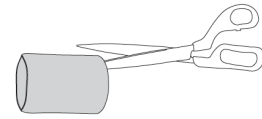

3 Cut cylinder in half with scissors

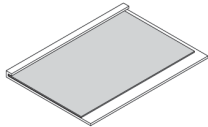

4 Place flat can in thicker metal bending tool

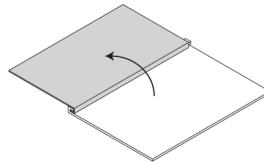

5 Bend flat can over to create ridged edges on both sides

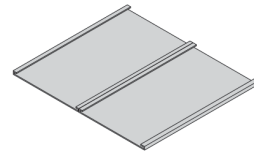

6 Place cans side by side

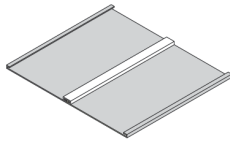

7 Lock the pieces together with bent metal cap

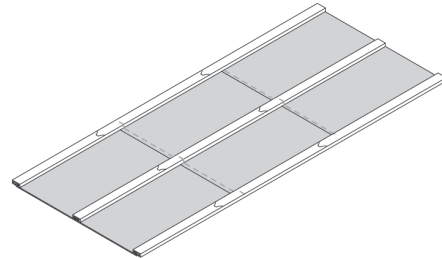

8 Overlap cans and caps to shed water

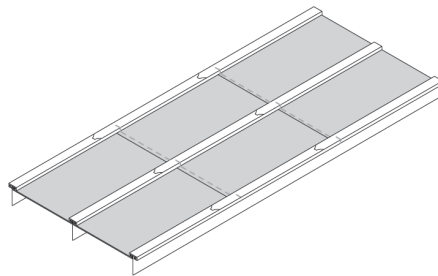

9 Insert aluminum tie backs for connection to structure

Aluminum cladding construction process

*Waste Management*

Lack of waste management in the commune is posing severe health risks to the residents of Tonle Sap Lake. There are currently no toilets available in the village, and proposals for future toilets do not yet accommodate the high water fluctuations on the site. The Center proposes a type of composting toilet where mobile containers that sit beneath the main floor collect the waste and are then transported to a facility (proposed in Phase 2 of this report) for processing.

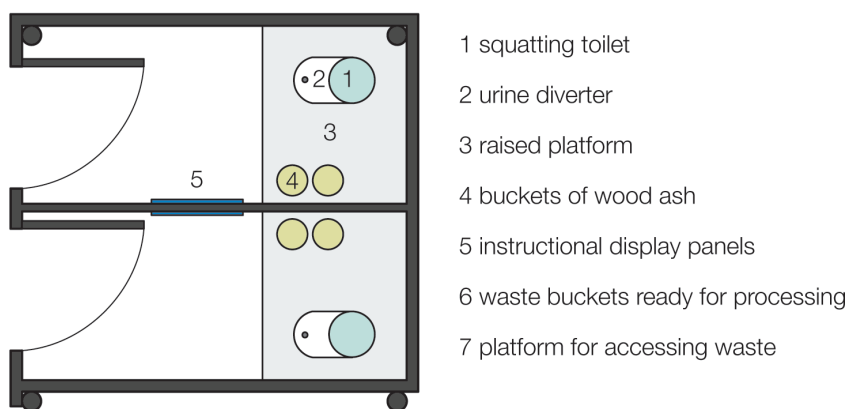

Toilet plan

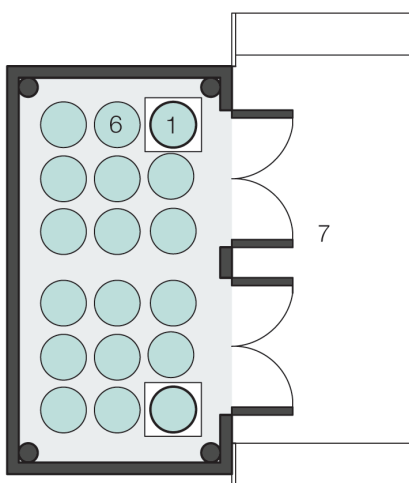

Waste storage plan

Urine diversion  
squatting toilet  
developed by  
EWBA (Torres  
2010).

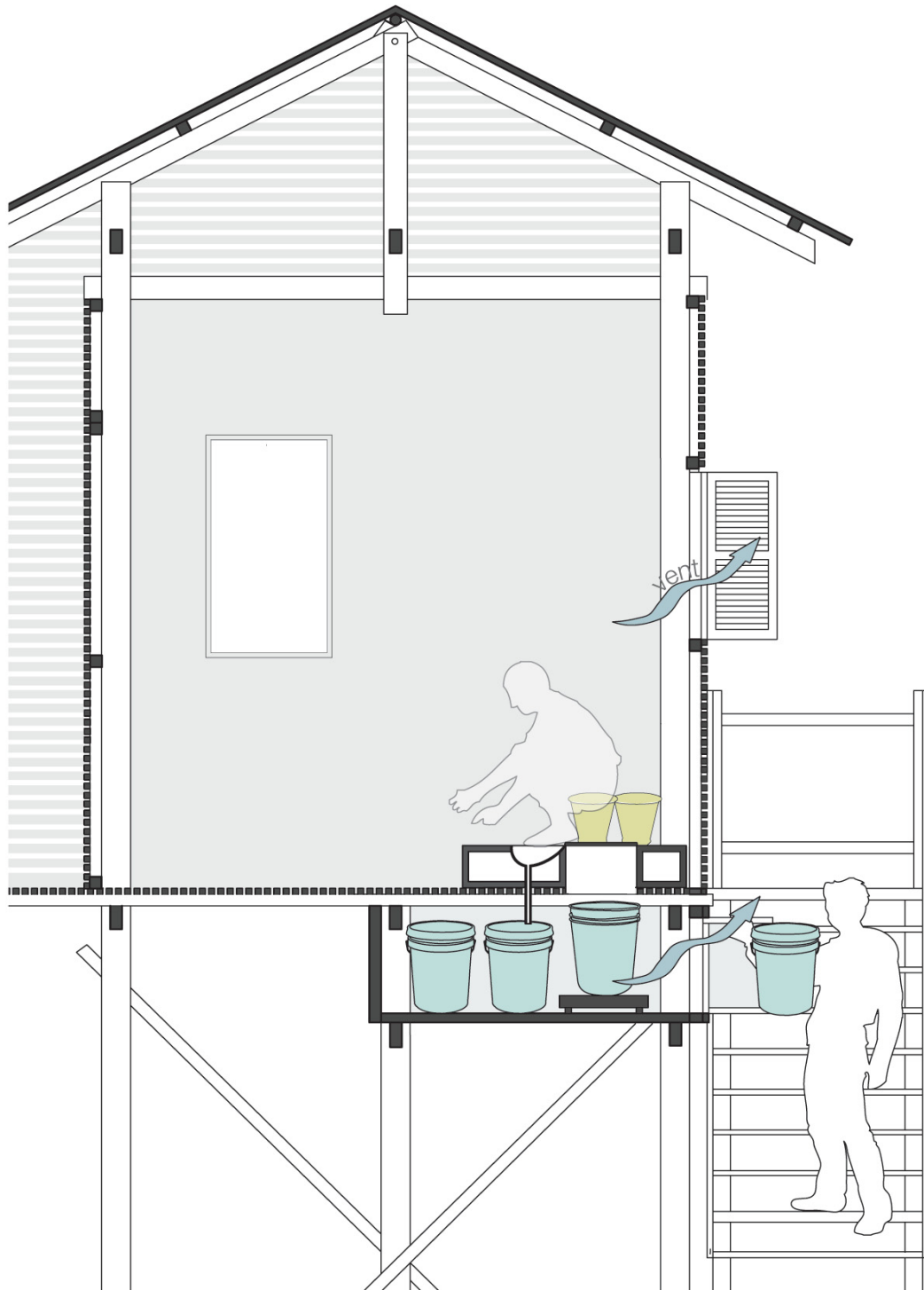

Section through toilet

## PHASE 2 WASTE PROCESSING

With instability in the world prices of fuel and increasing prices in food supply, rural people are faced with the challenge of finding inexpensive alternative sources of fuel and agricultural inputs. The traditional use of firewood as an alternative source of energy promotes destruction of the forest and causes respiratory illnesses to those who cook with it (primarily women).

As a way to provide an alternate low-cost fuel, decrease the degradation of the surrounding forest and introduce a strategy for waste management, this design proposes a bio digestion facility that will be built in the immediate years following construction of the Education Center.

This phase of the project promotes sustainable management of waste by processing human waste and fish guts produced at the Center into methane gas which can then be used to cook, boil water, and provide electricity. Since 80% of the villagers in Kompong Phluk currently collect wood for cooking, proposing an alternate fuel would greatly reduce the stress on the surrounding flooded forest (Marschke 2005, 90). The slurry produced as a by-product of the bio digestion process can also be distributed to villagers for fertilizing crops or gardens since 57% of villagers grow their own vegetables (Marschke 2005, 90).



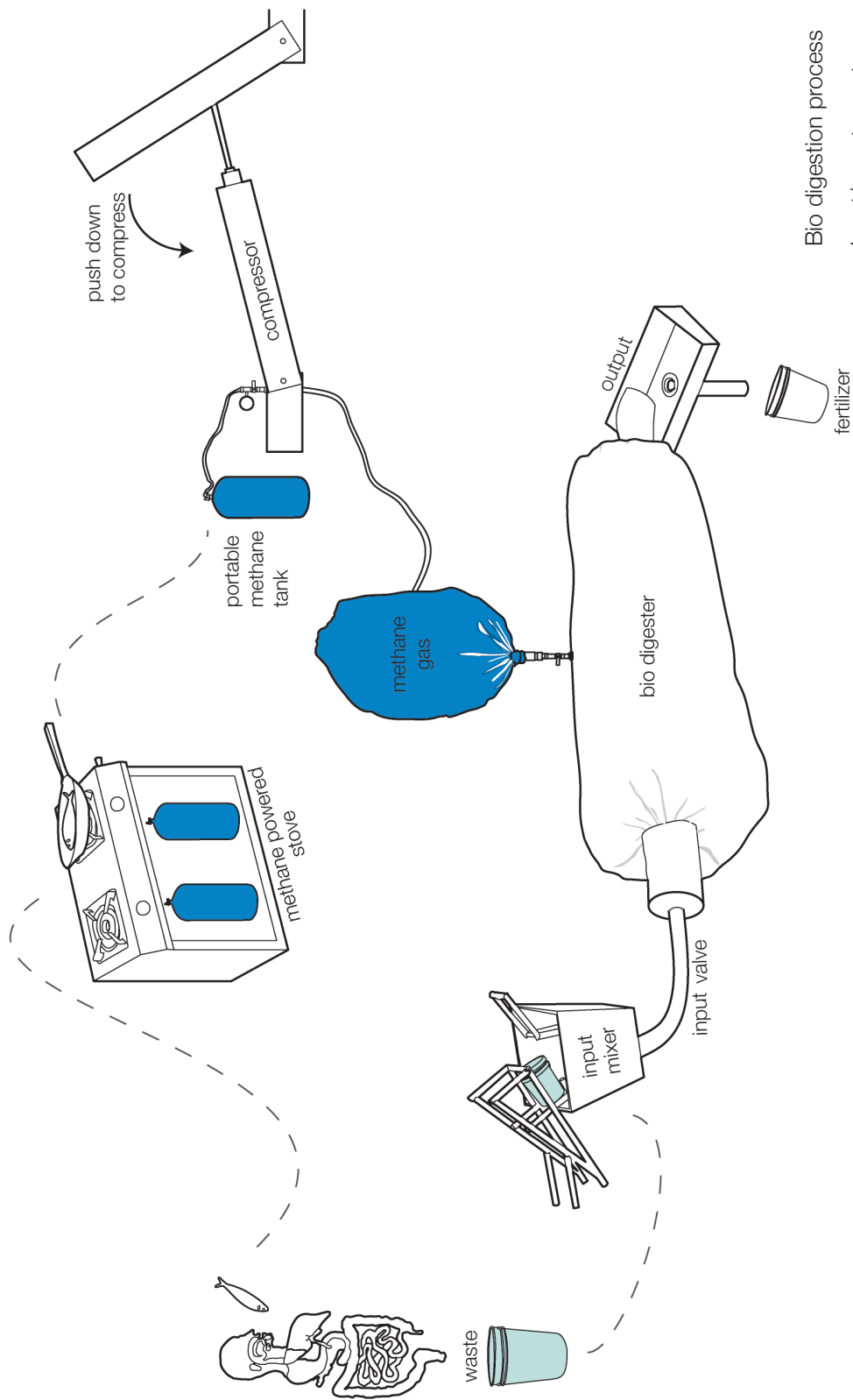

Bio digestion process  
Input/output system  
and compressor  
developed by EWBA  
(Torres 2010).

## Objectives

The bio digester will be implemented as a prototype that focuses on:

- 1) feasibility (materials and labor available in the village, the adoption of the technology by residents) and
- 2) integration into existing vernacular (making a building type that the residents will understand and inhabit).

## *Feasibility*

The small bio digester will be built by the cheapest means possible, with the intention that, as villagers use and understand the technology, 4-5 medium income families would also adopt the technology to fuel their own homes. The bio digestion facility will employ one full time worker from the village who will monitor the facility and educate the villagers on the process. The bio digester will require waste from 20-40 humans and will generate 1200-1600 liters of methane gas a day. This is enough gas to cook for 6-10 hours.

All materials used for construction are locally available and familiar to the residents. The facility draws upon the local construction methods of a typical floating house on Tonle Sap Lake to ensure ease of construction in future bio digestion facilities.

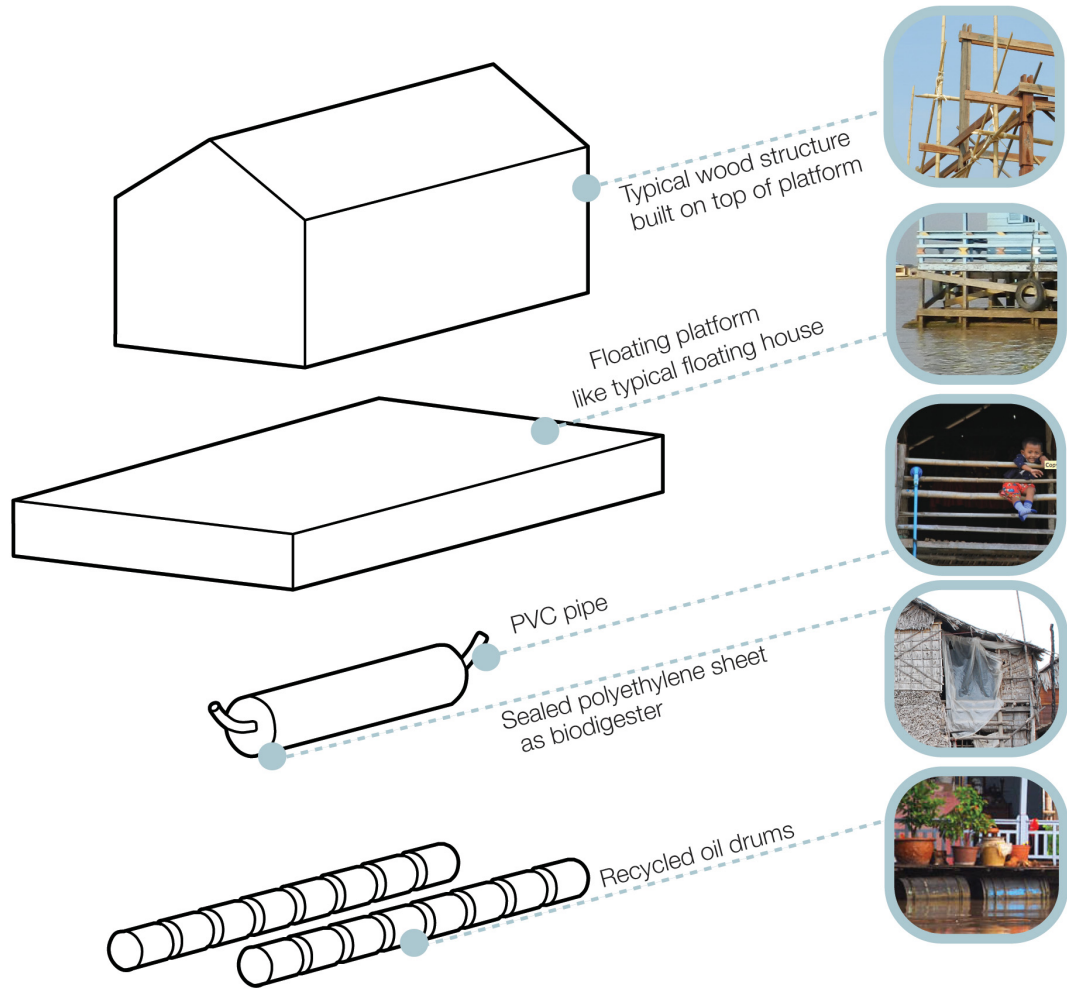

Drawing from the local material palette

### *Integration into Existing Vernacular*

A main requirement of the bio digestion processing facility is accommodation of the water fluctuations in the lake. While many low-cost bio digestion facilities developed in poor rural communities are buried underground, this is not an option for flood regions, since it may lead to contamination of the natural water source. In Kompong Phluk, the community would only be able to use an underground bio digester for 3-4 months a year when the commune is free of water. For this reason, it was decided that the facility needed to be a floating bio digester that would ride out the annual flood.

The concept of a floating bio digester on Tonle Sap Lake was introduced by Engineers without Borders Australia in 2010 (Torres 2010). In their project, the bio digester sits beneath a floating barge to accommodate the mobility of residents in different seasons. The buoyancy of the water counters the weight of the full bio digester. As the water recedes, the weight of the bio digester is transferred to the ground.

The design of the facility proposed for Tonle Sap Lake evolved from a study of floating houses on the lake and of gas station typologies in the region. It consists of a roofed barge that permits easy viewing of operation, with a lockable room to ensure secure methane gas during non-processing hours.

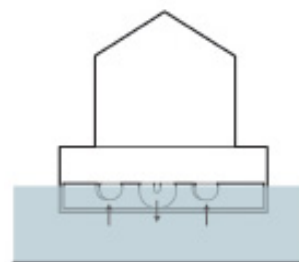

In monsoon season, the buoyancy force supports the weight of the bio digester

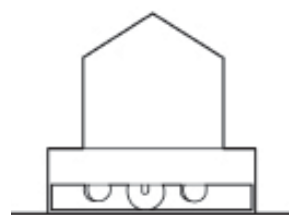

In dry season, the weight is transferred to the ground

Floating bio digester

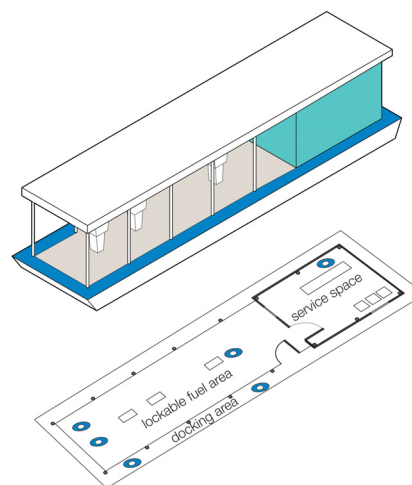

Typology of floating gas stations

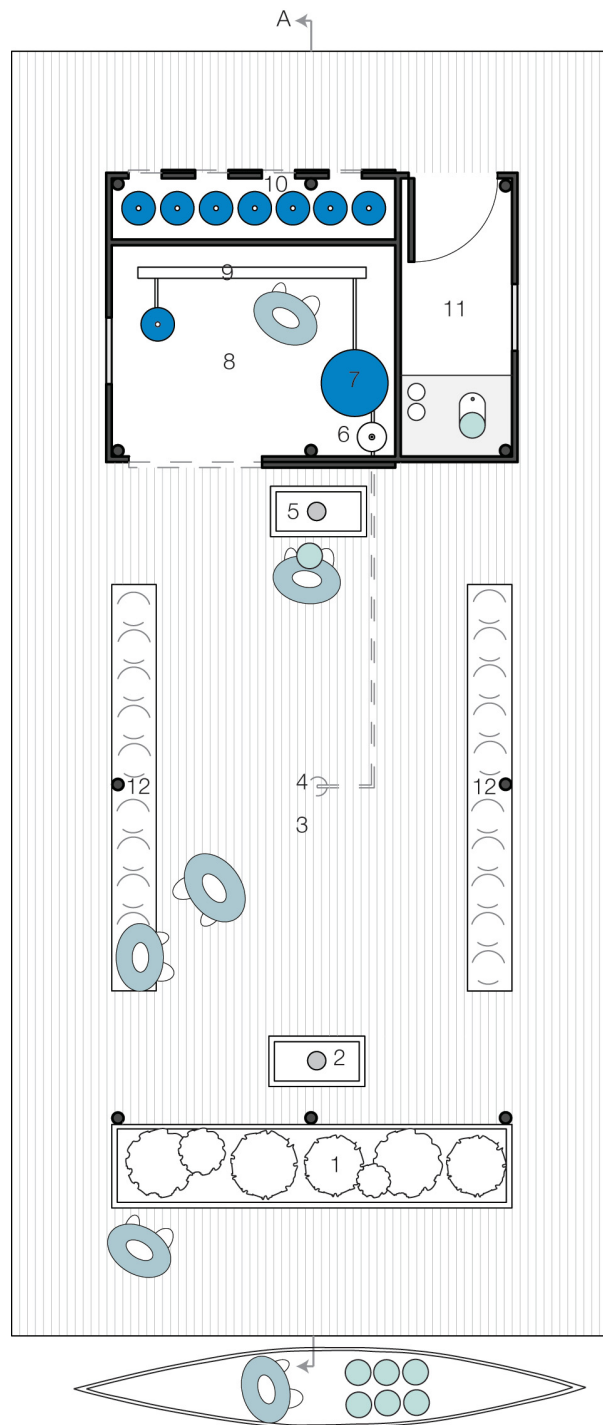

- 1 Garden
- 2 Slurry output
- 3 Floating platform
- 4 Methane pipe
- 5 Waste input
- 6 Flame trap
- 7 Methane storage
- 8 Gas handling area
- 9 Compressor
- 10 Methane tank storage
- 11 Toilet
- 12 Bench/waste storage



Plan  
Bio digestion processing facility

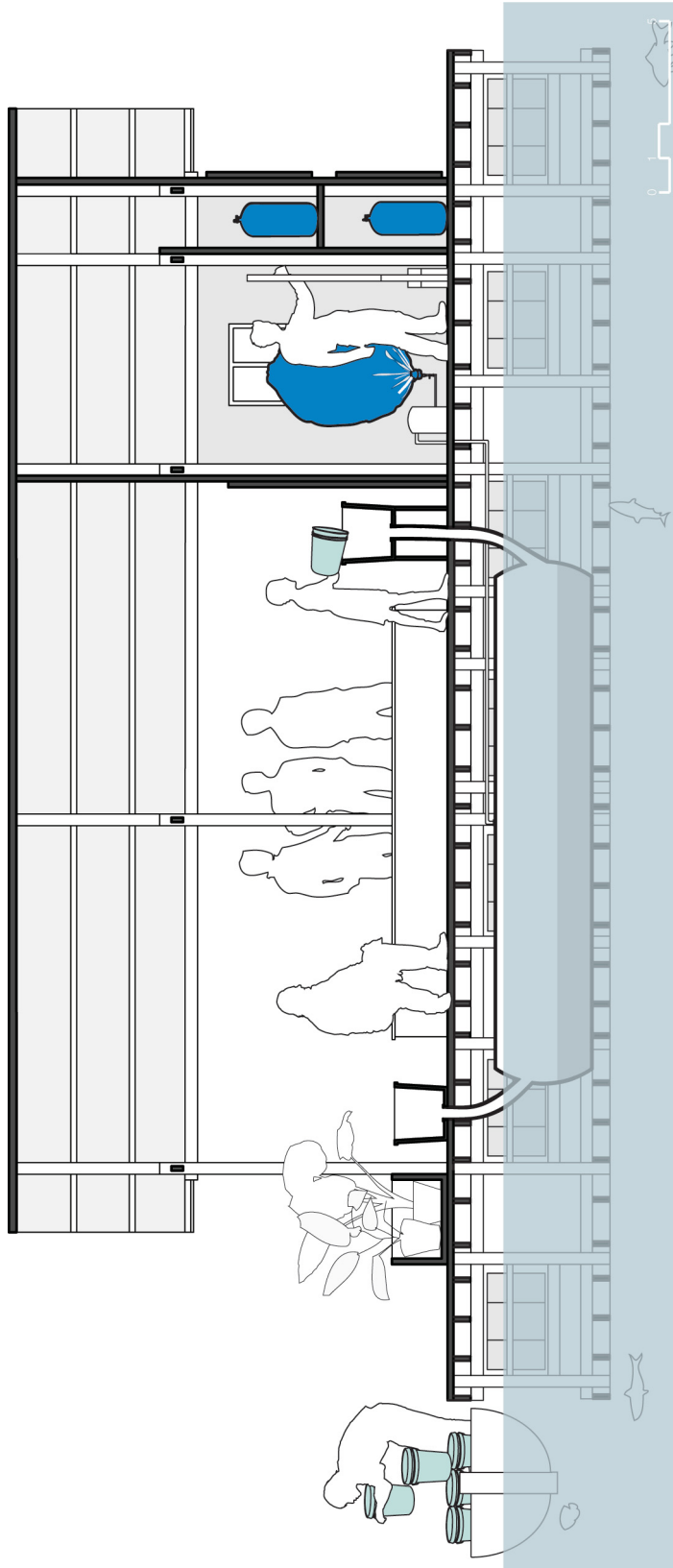

Section A

## CHAPTER 3: CONCLUSION

This thesis argues that the design and programming of a rural N.G.O center for education can propel economic and social development in rural populations of Cambodia. Rather than implement solutions to introduce change, this thesis provides the knowledge and training necessary to enable change to occur.

The architectural design focuses on the making of village scale infrastructure that can programmatically aid the community in mobilizing education as well as several small interventions that can be applied at the scale of the residential dwelling. Each solution closely considers the cost and availability of materials to ensure the adoption of the technology by residents, who are among the poorest people in Cambodia.

This thesis proves that through use of the familiar and the affordable, not only can development occur, but it can be sustained and improved over time by local residents. It demonstrates how the lives of 1 million people in Tonle Sap Lake can be radically improved through intimate interventions and the determination of one commune to preserve their resources.

## AFTERWORD

This thesis topic was generated from my interest in developing a method for designing sensitive architecture in traditional vernacular societies, without a particular site in mind. That being said, I think it is important to emphasize that while this research focuses on rural communities in Cambodia, many of the principles and methods developed in this work are transferable to any architectural project anywhere in the world.

One of the most successful and transportable lessons in this work are the methods generated for studying an international site and the identification of village patterns and typologies. These studies set up a framework to determine what 'should' be built by understanding what exists and what would add to and improve the existing. That study could be carried out in any location before schematic design to create architecture that is harmonious with its surroundings.

Through the development of various building systems in this project, I researched many topics that may be considered 'outside the discipline' such as wood preservation strategies, rainwater collection, waste management, and bio digestion. Many of these systems are directly transferable to other developing countries, aiding poor communities architecturally through improving their living conditions or even improving health or economic conditions. Beyond the specifics of each system, an important lesson is the inter-connectedness of the disciplines and



their dependence on one another. For example, it was impossible to suggest a solution for clean water without proposing a waste management solution or suggest putting a halt to the use of firewood for cooking without proposing an alternate solution for fuel. With each problem depending on the next, it became crucial to this project to look outside the typical 'boundaries' of the architectural discipline in order to design a building that solved more problems than it created. This is a lesson I will take with me to future projects, the inter-connectedness of social, economic and architectural problems and what we can do, as architects, to solve them.

## REFERENCES

- Acker, David, and Lavinia Gasperini. 2009. *Education for Rural People: The Role of Education, Training and Capacity Development in Poverty Reduction and Food Security*. Rome: Food and Agriculture Organization of the United Nations.
- Asian Development Bank. 2007. Saving Cambodia's Great Lake. Documentary Film. <http://www.adb.org/Water/Knowledge-Center/dvds/cambodia-great-lake.asp>.
- Atkin, Tony, and Joseph Rykwert. 2005. *Structure and Meaning in Human Settlements*. Philadelphia: University of Pennsylvania Museum of Archaeology and Anthropology.
- Baran, E. 2005. *Cambodian Inland Fisheries: Facts, Figures and Context*. Worldfish Center and Inland Fisheries Research and Development Institute. Phenom Penh: Ganad.
- Bennett, Nicholas. 1970. Primary Education in Rural Communities: An Investment in Ignorance. *Journal of Development Studies* 6, 4: 92-103.
- Bourdier, Jean-Paul, and Nezar AlSayyad. 1989. *Dwellings, Settlements, and Tradition: Cross-cultural Perspectives*. Lanham: University of America.
- Brand, Stewart. 1994. *How Buildings Learn: What Happens after They're Built*. New York: Viking.
- Brown, Barry. 2011. Kompong Phluk Street Elevation. Photograph. Private collection.

- Bruntland Report. 1987. *Our Common Future: The World Commission on Environment and Development*. New York: Oxford University Press.
- Caldeira, Fernando. 2010. Boron in Wood Preservation A Review in Its Physico-Chemical Aspects. *Silva Lusitana* 18, 2: 179-96. <http://www.scielo.oces.mctes.pt/pdf/slu/v18n2/v18n2a05.pdf>.
- Chan, R., and V. Chheang. 2008. Cultural Challenges to the Decentralization Process in Cambodia. *Ritsumeikan Journal of Asia Pacific Studies* 24: 1-16.
- Ellis, Frank. 1998. Household Strategies and Rural Livelihood Diversification. *Journal of Development Studies* 35, 1: 1-38.
- Knott, Albert, and George Nez. 2005. *Latex Concrete Habitat: A Manual on Construction of Roofs for Recovery from World Poverty*. Victoria: Trafford.
- Mann, Dennis A. 1985. Between Traditionalism and Modernism: Approaches to a Vernacular Architecture. *Journal of Architectural Education* 39, 2: 10-16.
- Marschke, Melissa. 2005. Livelihood in Context: Learning with Cambodian Fishers. Ph. D. diss., University of Manitoba.
- Moeung, Dara. 2001. Health Implications for Women and Children of Wood Fuel Use in Cambodia. *Energia News* 4, 4: 2-4. [www.energia.org/fileadmin/files/media/EN122001\\_moeung.pdf](http://www.energia.org/fileadmin/files/media/EN122001_moeung.pdf).

Obanda, Diana N. 2008. Reducing Leaching of Boron-based Wood Preservatives – A Review of Research. *Bioresource Technology* 99, 15: 7312-322. <http://www.sciencedirect.com/sciencearticle/pii/S096085240800028X>.

Oliver, Paul. 2003. *Dwellings*. London: Phaidon.

Poole, Colin. 2005. *Tonle Sap: The Heart of Cambodia's Natural Heritage*. Bangkok: River Books.

Rapoport, Amos. 1980. Vernacular Architecture and the Cultural Determinants of Form in *Buildings and Society: Essays on the Social Development of the Built Environment*, 283-301. Edited by Anthony D King. London: Routledge and Kegan Paul Ltd.

Rudofsky, Bernard. 1964. *Architecture without Architects*. New York: Museum of Modern Art.

Saunders, Graham. 2008. *Cambodia: The Essential Guide to Customs and Culture*. New York: Kuperard.

Schumacher, E.F. 1974. *Small is Beautiful: a Study of Economics as if People Mattered*. London: Sphere Books.

Tainturier, Francois. 2006. *Wooden Architecture of Cambodia*. Phnom Penh: Center for Khmer Studies.

Thomas, T.H., and D.B. Martinson. 2007. *Roofwater Harvesting: A Handbook for Practitioners*. Delft, IRC International Water and Sanitation Centre. Technical Paper Series 49: 1-160. <https://we.riseup.net/assets/4866/Roofwater%20harvesting%20handbook.pdf>.

Torres, Arthur, et al. 2010. Tonle Sap Sanitation Project: Floating Community Waste Management Station. Engineers without Borders Australia. [www.ewb.org.au](http://www.ewb.org.au).

Water and Sanitation Program. (W.S.P.) 2008. Economic Impacts of Sanitation in Cambodia Summary, A five country summary conducted in Cambodia, Indonesia, Laos PDR, The Philippines and Vietnam under the Economics of Sanitation Initiative (ESI), by the World Bank Report. [www.wsp.org/UserFiles/file/529200894119\\_ESI\\_Short\\_Report\\_Cambodia.pdf](http://www.wsp.org/UserFiles/file/529200894119_ESI_Short_Report_Cambodia.pdf).

Wright, Geoff, et al. 2004. Establishment of the Tonle Sap Basin Management Organization. Asian Development Bank & Cambodia National Mekong Committee. Tonle Sap Basin Profile. [http://www2.adb.org/Projects/Tonle\\_Sap/tonle-sap-basin-profile.pdf](http://www2.adb.org/Projects/Tonle_Sap/tonle-sap-basin-profile.pdf).