

A GEOPHYSICAL STUDY OF THE LISCOMB SATELLITE PLUTON

AN HONOURS THESIS
BY
JOHN JENNINGS
MARCH 13, 1989

Distribution License

DalSpace requires agreement to this non-exclusive distribution license before your item can appear on DalSpace.

NON-EXCLUSIVE DISTRIBUTION LICENSE

You (the author(s) or copyright owner) grant to Dalhousie University the non-exclusive right to reproduce and distribute your submission worldwide in any medium.

You agree that Dalhousie University may, without changing the content, reformat the submission for the purpose of preservation.

You also agree that Dalhousie University may keep more than one copy of this submission for purposes of security, back-up and preservation.

You agree that the submission is your original work, and that you have the right to grant the rights contained in this license. You also agree that your submission does not, to the best of your knowledge, infringe upon anyone's copyright.

If the submission contains material for which you do not hold copyright, you agree that you have obtained the unrestricted permission of the copyright owner to grant Dalhousie University the rights required by this license, and that such third-party owned material is clearly identified and acknowledged within the text or content of the submission.

If the submission is based upon work that has been sponsored or supported by an agency or organization other than Dalhousie University, you assert that you have fulfilled any right of review or other obligations required by such contract or agreement.

Dalhousie University will clearly identify your name(s) as the author(s) or owner(s) of the submission, and will not make any alteration to the content of the files that you have submitted.

If you have questions regarding this license please contact the repository manager at dalspace@dal.ca.

Grant the distribution license by signing and dating below.

Name of signatory

Date

ABSTRACT:

The Liscomb Satellite Pluton is located to the north of the Main Liscomb Complex in central Nova Scotia. Because of the limited amount of outcrop the boundaries of the pluton have yet to be accurately determined through geology. However due to the density contrast that exist between the granite and the surrounding metasedimentary rocks, the boundaries of the pluton can be determined using contoured Bouguer gravity values which show a 5.0 mgal low centered over the pluton.

13 refraction lines were shot over the study area with two purposes in mind: 1. To determine the thickness and the variation of the till layer, which would then allow for the 'stripping' of the till layer from the Bouguer gravity values. 2. To determine if bedrock differentiation is possible due to their differences in seismic velocity. The refraction profiling determined that the subsurface can be approximated by three layers; a till layer (velocity ~1700 m/sec), a weathered layer (velocity ~3500 m/sec) and basement (velocity ~ 5000 m/sec). Determination of the basement type i.e. granite versus metasediments was not possible to the inaccuracy of the seismic profiling.

The gravitational attraction of the till layer is ~.2 -.3 mgals, which is insignificant and can therefor be ignored when modeling. The pluton model constructed, using a 3D modeling program, show a elliptical cylinder, with a cross section of 7 km by 3 km with a minimum depth of 10 km. No contact is evident to the Main Liscomb Complex above 1.0 km. Depth to the surface closely approximates a plane.

TABLE OF CONTENTS:

Abstract.....	i
Introduction.....	1
Data Acquisition.....	9
Data Reduction.....	11
Topographic Correction.....	13
Calculation of Errors.....	14
Seismic Results.....	17
Consequences for Gravity.....	21
Gravity Modeling.....	24
Constraints on Modeling.....	26
Gravity Results.....	28
Discussion.....	42
Conclusion.....	44
References.....	46
Appendix A.....	48
Appendix B.....	66

FIGURES:

#1 Regional Geology.....	1
#2 Contour Map of Bouguer Gravity.....	3
#3 2.5D Model.....	4
#4 3D Model - Block Model.....	5
#5 Contour Map of Observed and Calculated Gravity.....	6
#6 Distribution of Seismic Lines.....	9
#7 Geometry of a Three Layer Model.....	12
#8 Geometry for Topographic Correction.....	13
#9 Seismic Record.....	15
#10 Graphical Error Determination.....	16
#11 Time - Distance Graph Illustrating a Fault.....	20
#12 Geology of Main Liscomb Pluton.....	27
#13 Updated 3D Model.....	29
#14 Geographical Location of Pluton.....	30
#15 Updated Contour Map of Observed and Calculated Gravity.....	31
#16 Profile A-A'-- North-South.....	32

#17	Profile B-B'-- West-East.....	33
#18	Profile C-C'-- Northwest-Southeast.....	35
#19	Gravity Anomaly From Depth.....	36
#20	3D Model Using a Contact.....	37
#21	Contour Map of Calculated Gravity: Contact Model.....	38
#22	Profile A-A'-- North-South: Contact Model.....	39
#23	Profile B-B'-- West-East: Contact Model.....	40
#24	Profile C-C'-- Northwest-Southeast: Contact Model.....	41

TABLES:

#1	Range of Rock Velocities.....	8
#2	Velocities, Dips and Depths of Layers.....	18
#3	Gravity Correction Due to Till.....	22
#4	Prism Parameters for 3D Model.....	28

INTRODUCTION:

This study is a follow up to work done by Brogan (1988) on the Liscomb Satellite Pluton of central Nova Scotia. The Liscomb Complex and the surrounding metasedimentary rocks have been mapped using geological data accumulated through field mapping of Nova Scotia (Keppie, 1979; Bujak and Donohoe, 1980; Giles and Chatterjee, 1987). However the location of the Liscomb Satellite Pluton had yet to be accurately determined. Figure #1 shows the regional geology of the

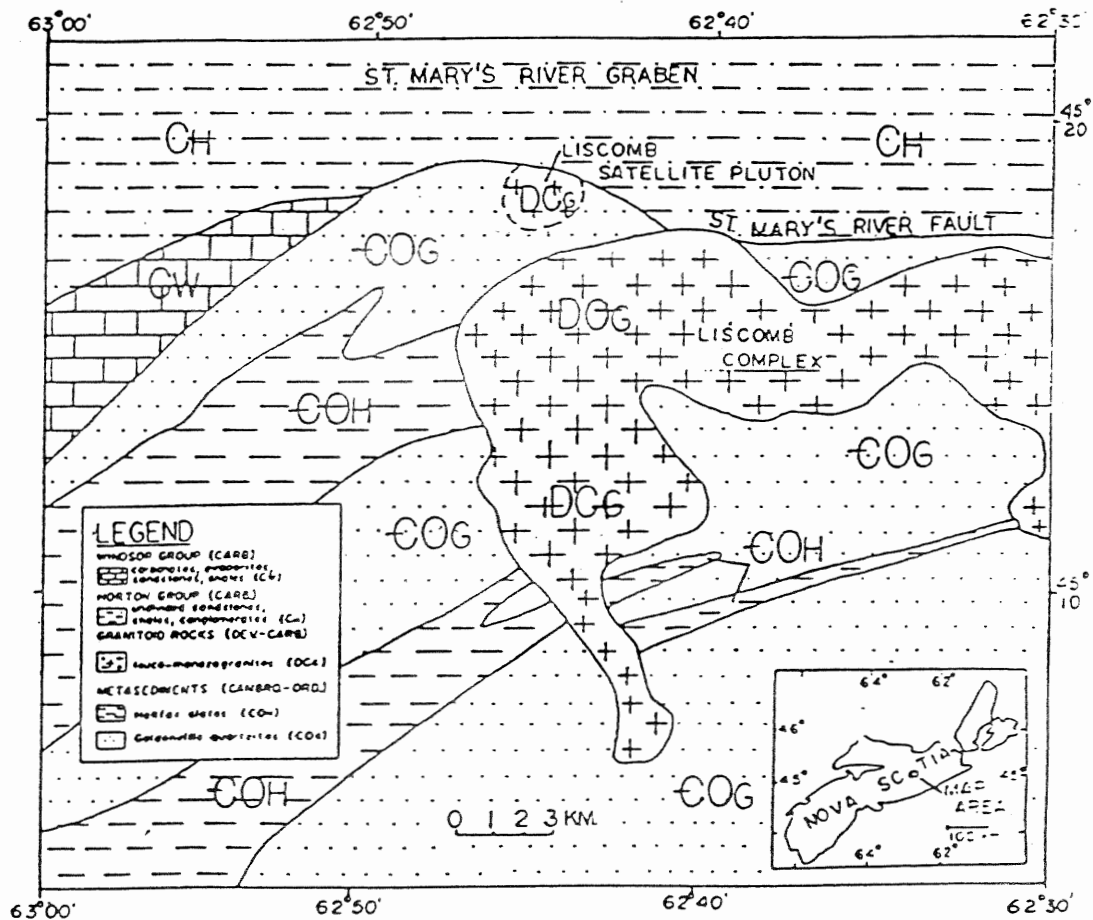

Figure #1. Regional geology of the study area.

area which consists of Cambro - Ordovician metasediments i.e. the Halifax slates and the Goldenville quartzites. These units were intruded during the Devonian - Carboniferous by numerous granitic plutons (Acadian Orogeny). During the Carboniferous, a second group of sedimentary and carbonate rocks - the Horton and Windsor Formation - were deposited. Deposition stopped with the initiation of the Hercynian Orogeny of the Carboniferous. Erosion, due to this uplift and latter glacial episodes, exposed the Main Liscomb Complex.

As the ice from the last Pleistocene glacial period regressed, it deposited a large amount of glacial till on the exposed bedrock. This glacial till layer limits present outcrop exposure, making field mapping of the area quite difficult. Brogan (1988) noted that while conducting his gravity survey over the Satellite Pluton he was unable to locate any outcrop of the pluton. No outcrop was seen during field work for this study. Figure #1 shows only the inferred location of the Pluton boundaries and although the Pluton is illustrated on numerous geological maps of Nova Scotia, its boundaries have not been accurately determined. It was because of the limited extent of outcrop and unknown boundary positions that Brogan conducted his gravity survey. Due to the density difference between the granite and the metasediments Brogan was able to delineate the boundary of the satellite pluton and its association with the Main Liscomb Complex through interpretation of the Bouguer gravity values.

Brogan (1988) interpreted the Bouguer gravity map of the

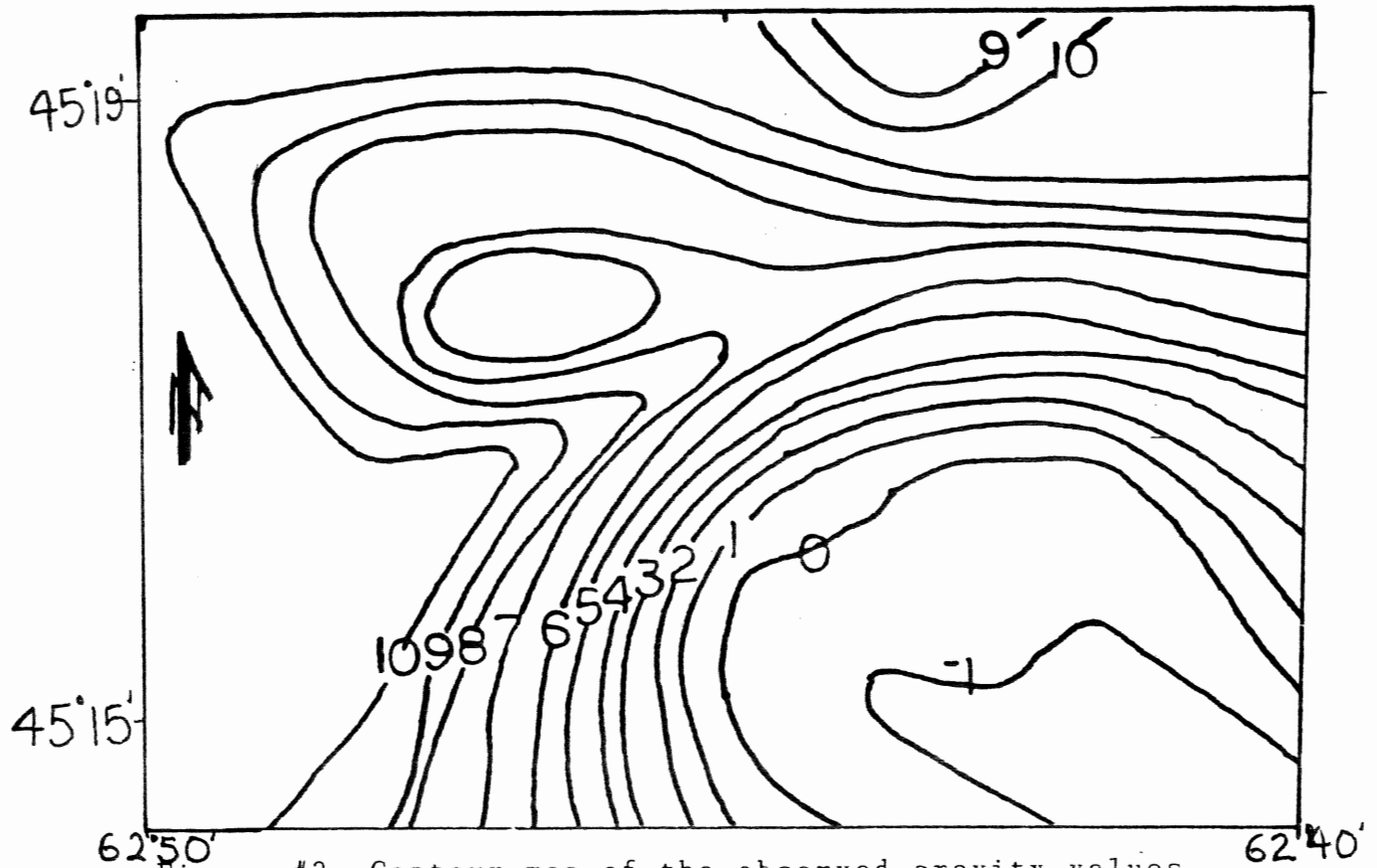

Figure #2. Contour map of the observed gravity values
From Brogan, 1988.

area (Figure #2) using both a 2.5 dimensional modeling program (Magrav), and a 3 dimensional modeling program (Threed). Magrav, the 2.5 dimensional program, calculates the gravitational effects of a buried n - sided polygon with a limited half-strike length. Figure #3 (Brogan, 1988) shows a north - south cross section for a pluton with a density contrast of $-.09 \text{ g/cm}$ with the surrounding host rock (metasediments), a half strike length of 1.5 km, and a depth to the top surface of zero - indicating an outcropping body. The 2.5 dimensional model which best fits the gravity data has steep boundaries, and requires no connection to the Main Liscomb pluton to a depth of at least 13 km. A

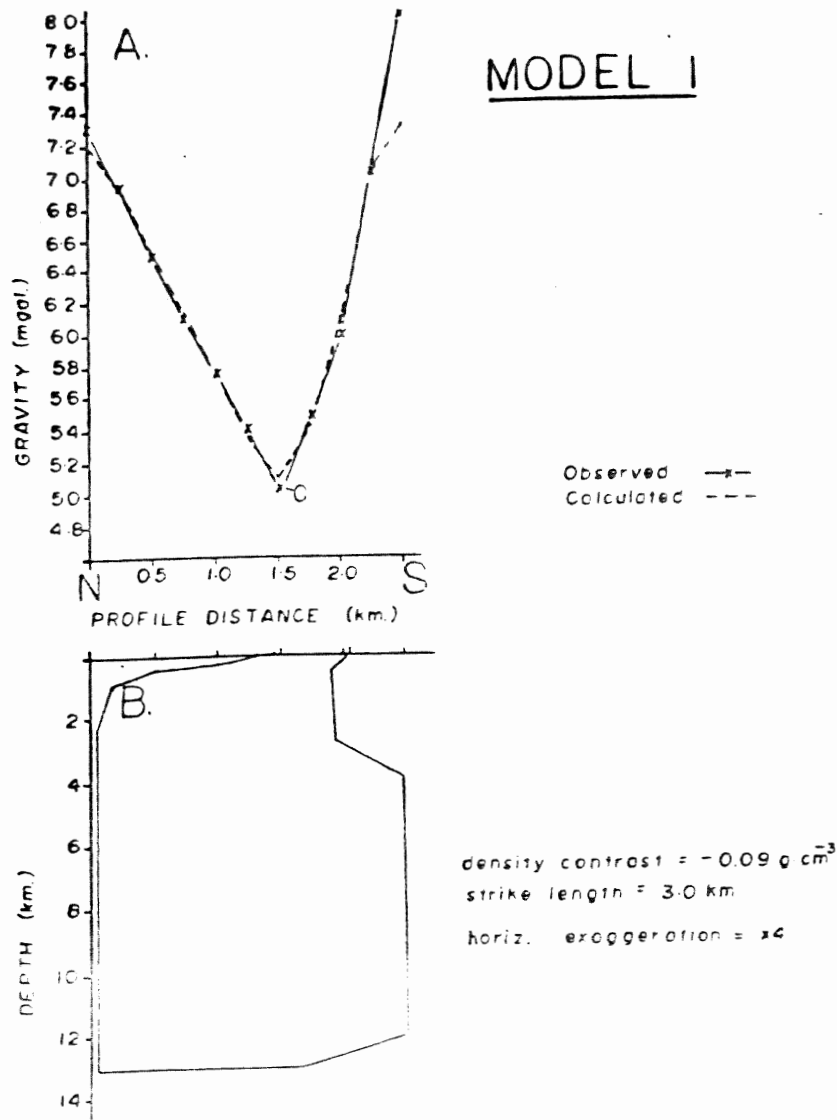

FIGURE #3. 2.5 dimensional model for a north-south cross section, after Brogan, 1988.

significant problem with the program is that the half strike length of the body acts as a scaling factor for the magnitude of the gravity anomaly. by increasing the half strike length an increase in mass of the body is assumed thus making the gravity anomaly larger. The inability to model the pluton as a three dimensional body means that the 2.5 dimensional model should only be used as a first approximation of the Pluton dimensions.

Threed - the 3 dimensional program - models the pluton as a number of vertical prisms with variable dimensions and depths.

Brogan (1988) modeled the data as a pluton with a concave-down, oval, upper surface, an east - west strike length of 4.0 km and a north - south strike length of 3.5 km. The body extends to at least 20 km in depth, and any attachment to the Main Liscomb Complex is at a minimum depth of .5 km. The best fit model uses a density contrast of .17 g/cc. Figure #4 shows the prisms used for the modeling. Brogan (1988) approximated the pluton by 30

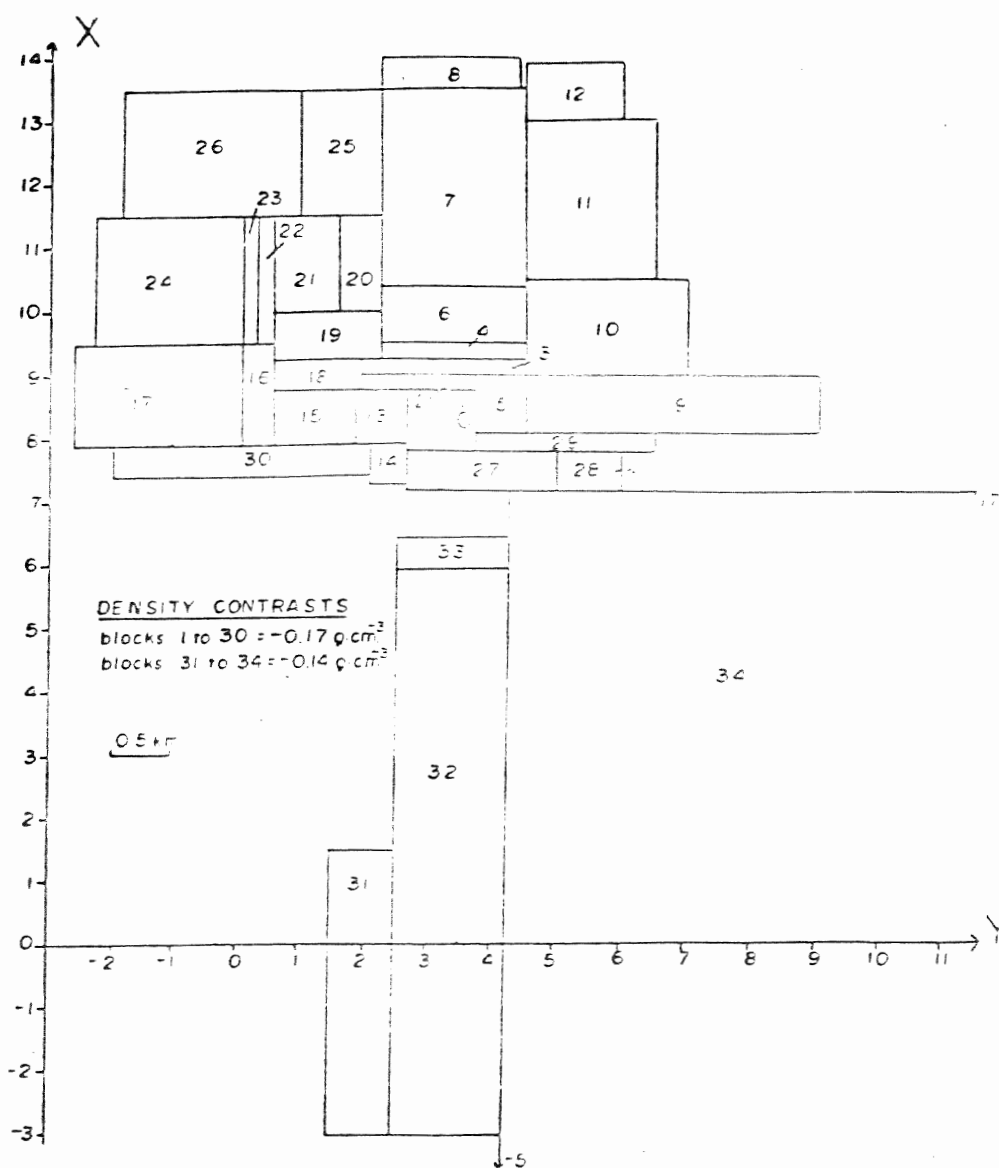

Figure #4.3 dimensional model from Brogan, 1988.

blocks each having variable cross sectional dimensions and varying depths to the their top. Brogan noted that the 3 dimensional model most accurately delineates the boundaries of the pluton. The accuracy of Brogan's model can be evaluated by comparing the observed gravity contours with those calculated from the 3 dimensional model. Figure #5 illustrates a good agreement between the calculated and observed gravity over the pluton.

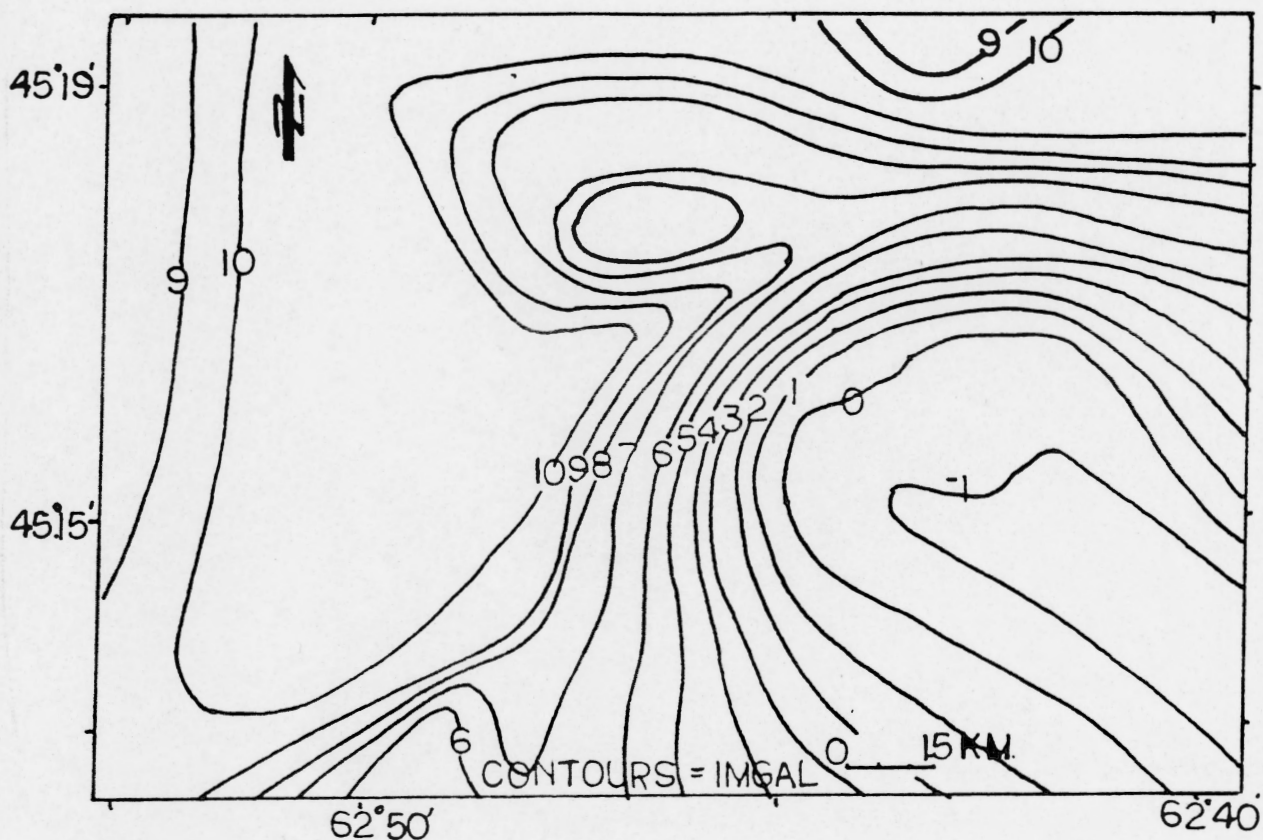
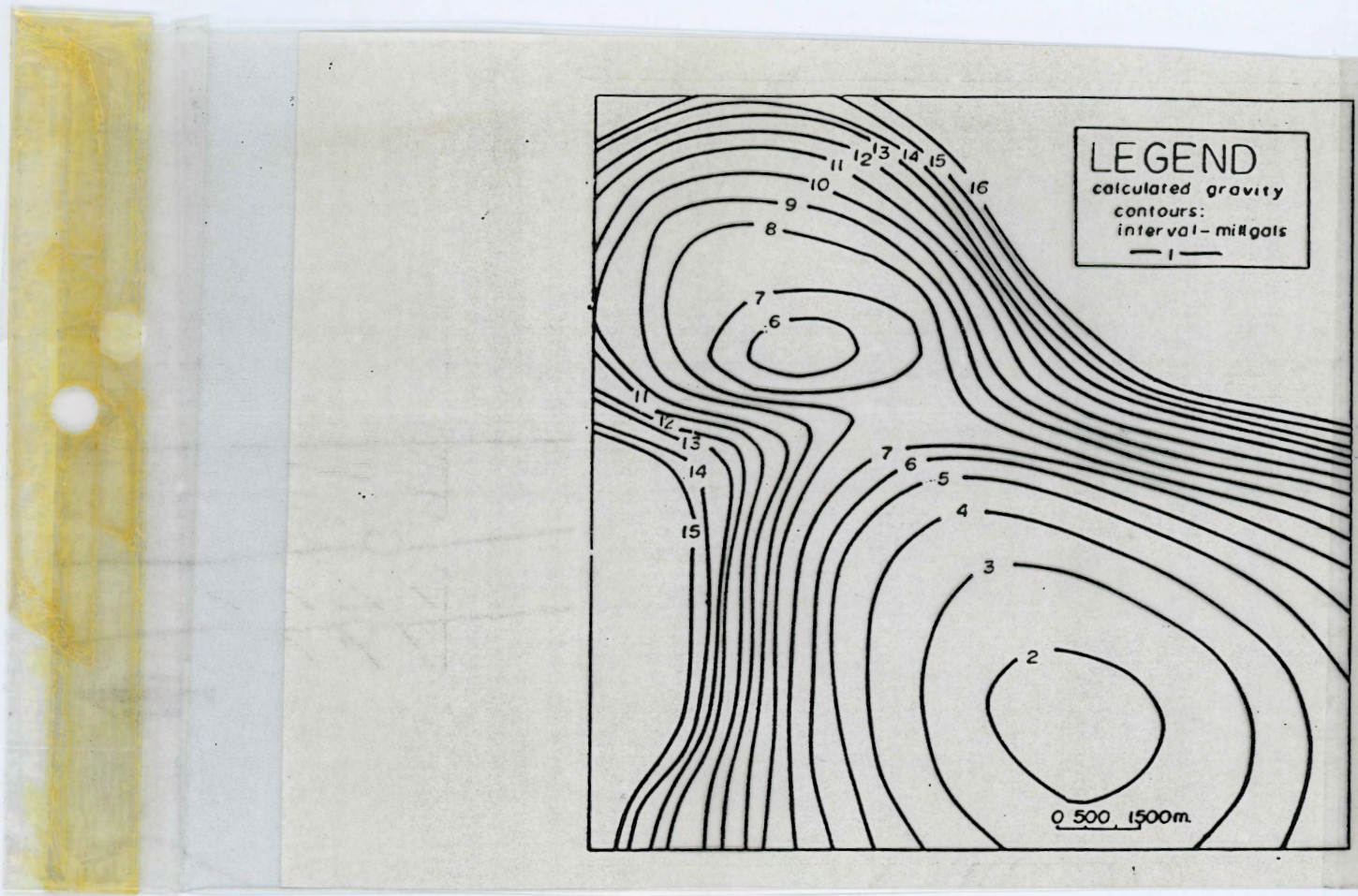

Figure #5. Contour map of the observed and calculated gravity

Dobrin and Savit (1988) stress two essential points that must be kept in mind on the examination of any gravity survey.

- the gravitational field measured at ground level is the total attraction contributed by all subsurface sources in the



Print as transparency and overlay previous page.
Align with punched hole.

region.

- the lack of uniqueness of a gravity field because of this summation of the subsurface sources means that an infinite number of different geological configurations can be constructed from identical gravity profiles.

This second point by Dobrin and Savit (1988) is over emphasized because the geology of the area places limits on possible subsurface geology.

An additional problem in the 1987/88 gravity survey carried out by Brogan is that due to limited access, no traverse completely ran the entire length or width of the body. Also the gravity field associated with the Main Liscomb Complex to the south affects the gravitational signature of the Liscomb Satellite Pluton. These problems cast some doubt into the accuracy of mapping using gravity surveying alone.

Also influencing the validity of the gravity data is the variable thickness of till. Brogan (1988) ignored the effect the till thickness has on the gravity values. The uncertainty in the gravity interpretation because of the till could be reduced if there was a reliable estimate of till thickness and knowledge of the variation in thickness over the study area. Refraction seismics can quantify the thickness of the glacial till (depth to the pluton) and thus allow for the determination of the till's effect on the gravity data.

The density contrast between the host metasedimentary rocks and the intruded pluton is estimated to be .17 g/cc (Brogan, 1988). Since the velocity of seismic energy in a rock is

dependent on density, the .17 g/cc contrast may result in a difference in seismic velocity. However, differentiating granite from metasediment may not be possible from their velocities. Table #1 shows the range of velocities for different rock types versus their frequency of occurrence. Grant and West (1965) determined a wide range of velocities for granitic and

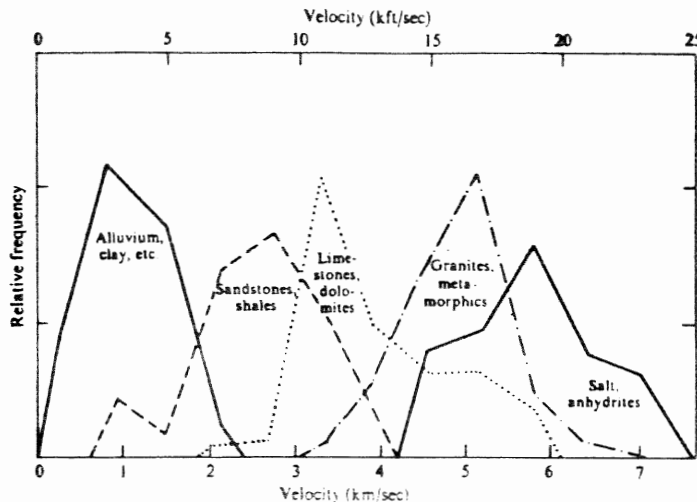

Table #1. Velocity of various rock types. from Grant and West, 1965.

metamorphic rocks i.e. from 3.0 km/sec to 7.0 km/sec. This velocity range is due both to the range of different mineral within any given rock type and the range of pressure and temperature experienced by the metasediments which determine the density of the rock. Thus while the contrast of densities is useful for gravity surveys, it may not produce a difference in velocities which are characteristic of the rock type.

With the seismically determined depth of overburden the effect of till on the Bouguer gravity values can be calculated and then stripped from the Bouguer gravity. The resulting gravity map would then be more representative of deeper bodies, therefor requiring the alteration of the model presented by

Brogan.

DATA ACQUISITION:

Seismic data was collected over three days in the fall of 1988; October 18th, November 16th, and December 9th.

In total 14 seismic lines were shot on or near the proposed location of the satellite pluton (Figure #6).

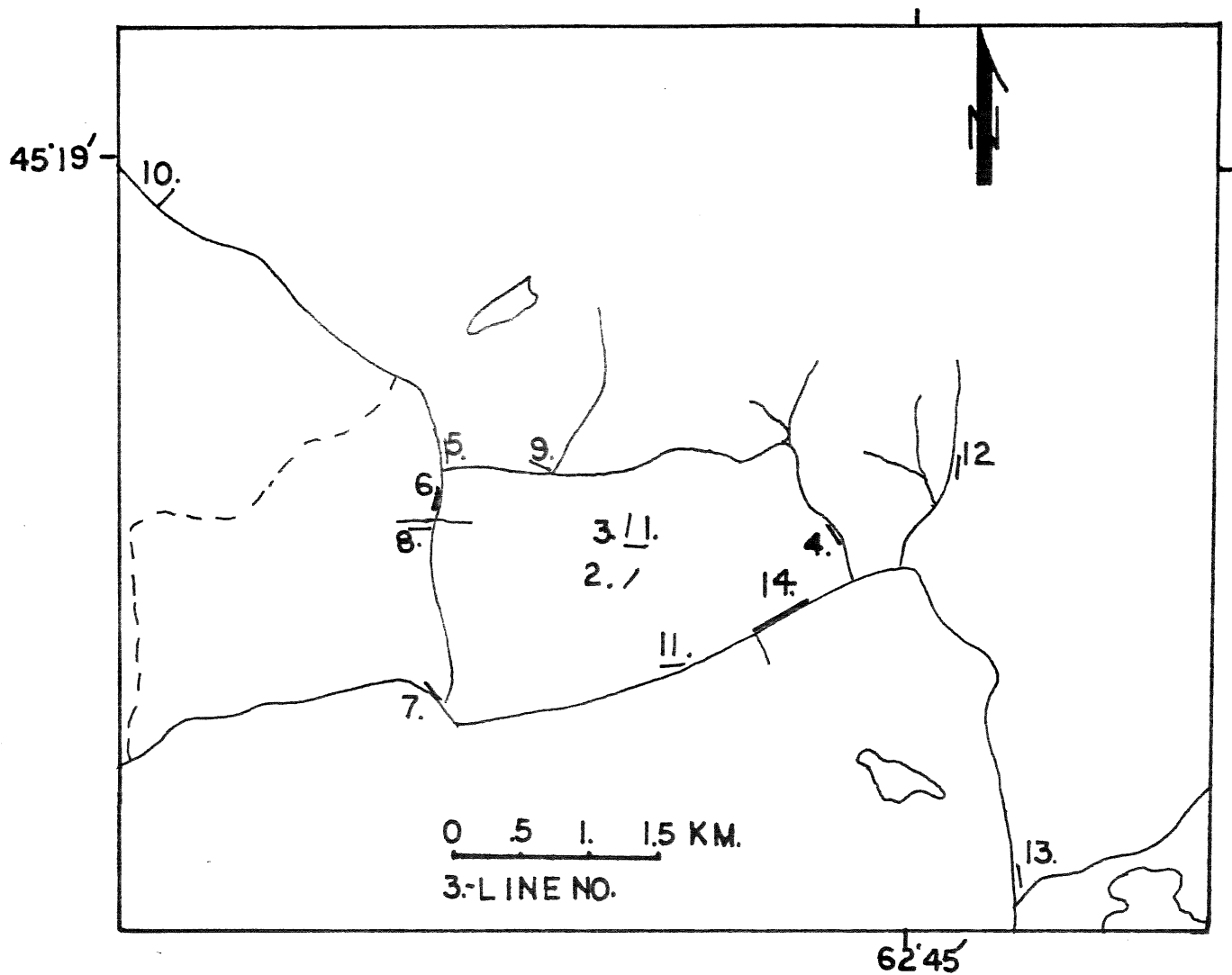

Figure #6. Distribution of seismic lines.

The location of these lines was governed by several factors:

- The accessibility to the area.
- The need for wide spread coverage over the pluton.
- The necessity of keeping the spread cable straight to reduce errors in the data
- The placement of some lines over the supposed position of the surrounding metasedimentary rocks to find out if they can be distinguished seismically from the granites. Thus several lines were shot off Brogans proposed boundaries of the Satellite Pluton.

Data was collected using a 12 channel seismograph. Lines #1 through #13 used a geophone spacing of 10 meters, while line #14 used a spread cable length of 720 meters (~66 metres between geophones) - see Appendix A for the seismic records. Distance from the shot point to the first geophone averaged 10 meters although this distance occasionally varied in order to achieve maximum coupling with the ground. Shooting the lines on relatively horizontal ground helped reduce errors in the arrival times of the first breaks. Geophone elevations were not surveyed in; the time saved allowed for more data collection, only line #4 needed the elevations of the geophones in order to make topographic corrections on the data.

Previous use of the seismic equipment, showed that the 'buffalo' gun would make the best energy source for the surveying parameters i.e. spread cable length of 120 meters. A buffalo gun consists of a metal tube down which a firing pin is dropped. The pin triggers a shell which is located in the bottom of the

tube. The buffalo gun which fires 12-gauge shotgun shells is portable and produces strong first breaks for relatively distant receivers - well within the 120 meter spread cable length. The buffalo gun is placed in a hole 25-50 cm in depth for firing. The hole is then filled with water to improve ground coupling between the energy source and the ground.

Line #13 was shot with a buffalo gun and a hammer source. While both energy sources produce good data resolution and ground penetration, the buffalo gun produces slightly clearer and better defined first breaks. (Appendix A - Line 13 - Rec. 1 & Rec. 2)

Tests were conducted to observe the quality of data obtainable by the 720 meter spread cable (Appendix A - Line 14-Rec. 1). Unfortunately the 12-gauge buffalo gun does not produce sufficient energy for such penetration. Future work with this cable requires the use of a larger energy source than the 12-gauge buffalo gun.

DATA REDUCTION:

Reducing refraction data to a usable form involves the determination of the arrival time of the seismic energy at each geophone and plotting these values versus the distance to each of the geophones. Both the normal and reversed shooting directions were plotted. Plotting of both directions allows for correction of the error introduced due to a dipping bed. Figure #7 (Mota, 1954) shows a representative graph of time versus distance for a double refractor or three layer case and the accompanying geological model. Field data suggests a three layer model.

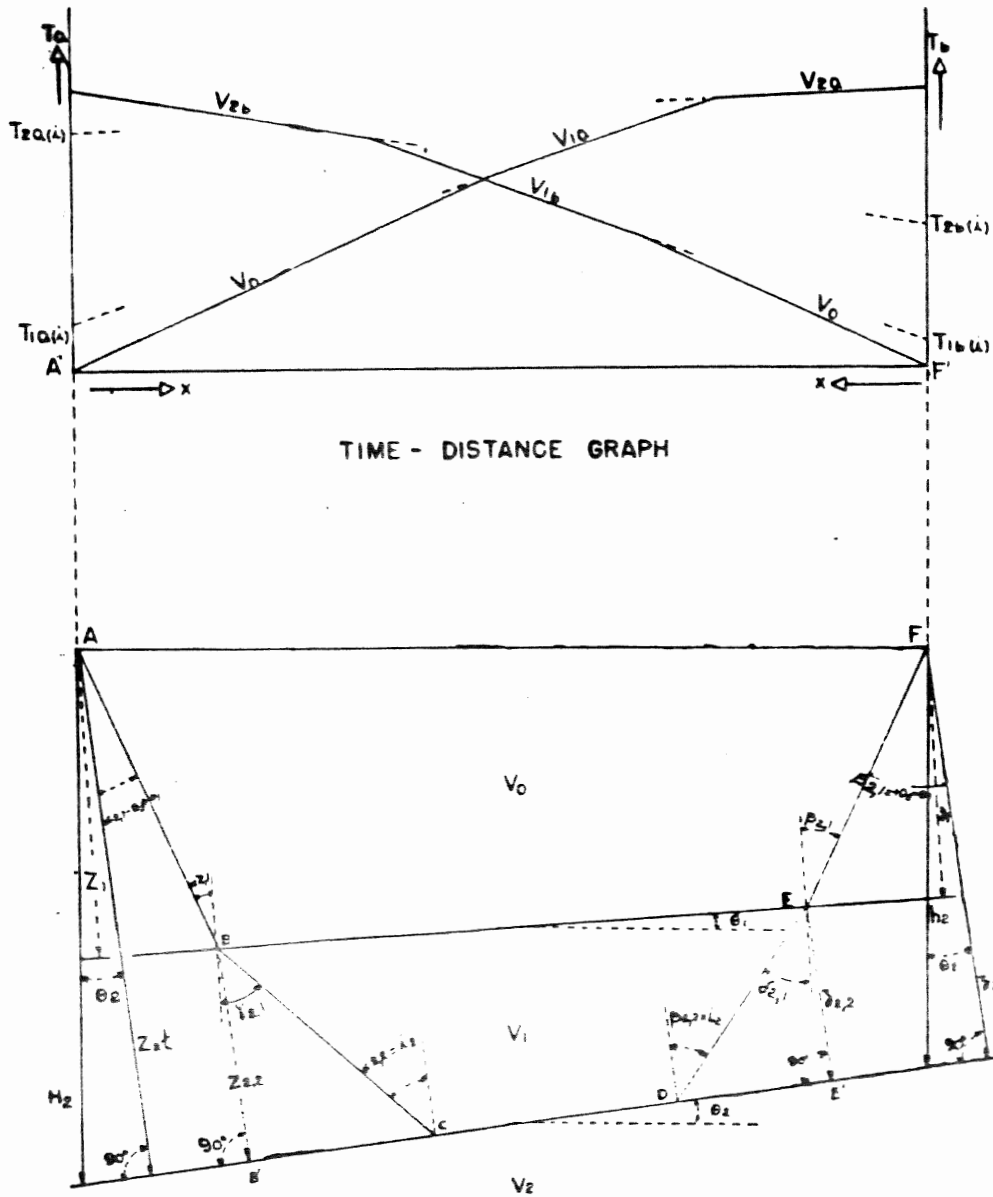

Figure #7. Geometry of the geological model used. Equations are in Appendix B. After Mota, 1954.

Using Mota's (1954) equations and the graphs determination of the layers velocities, thickness, and dip was possible. Appendix B shows the equations used for calculations for Line #1 - #13, excluding Line #3 which due to poor ground to geophone coupling produced useless results (see seismic records in Appendix A). Appendix B also shows the time - distance graphs for the seismic lines.

case. The extra time required for the wave to travel from the datum to the geophone must be added to the travel time if the datum is above the geophone or subtracted if the datum is below the geophone. The elevation correction for each geophone is

$$\text{elevation correction} = \frac{(e - h + E - 2d) * \sqrt{V_1^2 - V_0^2}}{V_1 * V_0}$$

where e is the elevation at the top of the shot hole, E the elevation of the geophone in question, d the elevation of the datum plane, and h the depth of the charge in the hole. This equation can be simplified by assuming that the shot location is on the datum plane. Thus e, h, and d become zero. The elevation correction is then only dependent on the velocities in layer 1 V_0 and layer 2 V_1 , and the elevation of each geophone.

(ii) CALCULATION OF ERRORS:

In this study there are 2 main sources of error which can be measured and corrected for: topography and determination of the times for first arrivals from the seismic records.

The effect of topography on the data is easy to quantify but difficult to correct for after the field work has been done. Using average velocities for V_0 of 1725 m/sec, and V_1 of 3500 m/sec the elevation correction associated with a 1 meter elevation difference between shot point and geophone is .50 msec. Such error from elevation can be eliminated by measuring the elevation of each geophone and making the necessary correction. However due to time constraints this was not possible for every

line. Error due to topography was minimized in the field by choosing relatively horizontal ground. The error due to not correcting for topography in these circumstances will be smaller than the second and more important source of error-determination of first arrival times.

Due to the quality of the seismographic records an error of .5 msec is introduced upon picking of the first arrival times at each geophone. Figure #9 shows a typical seismic record (Appendix A shows the remaining records used in this study).

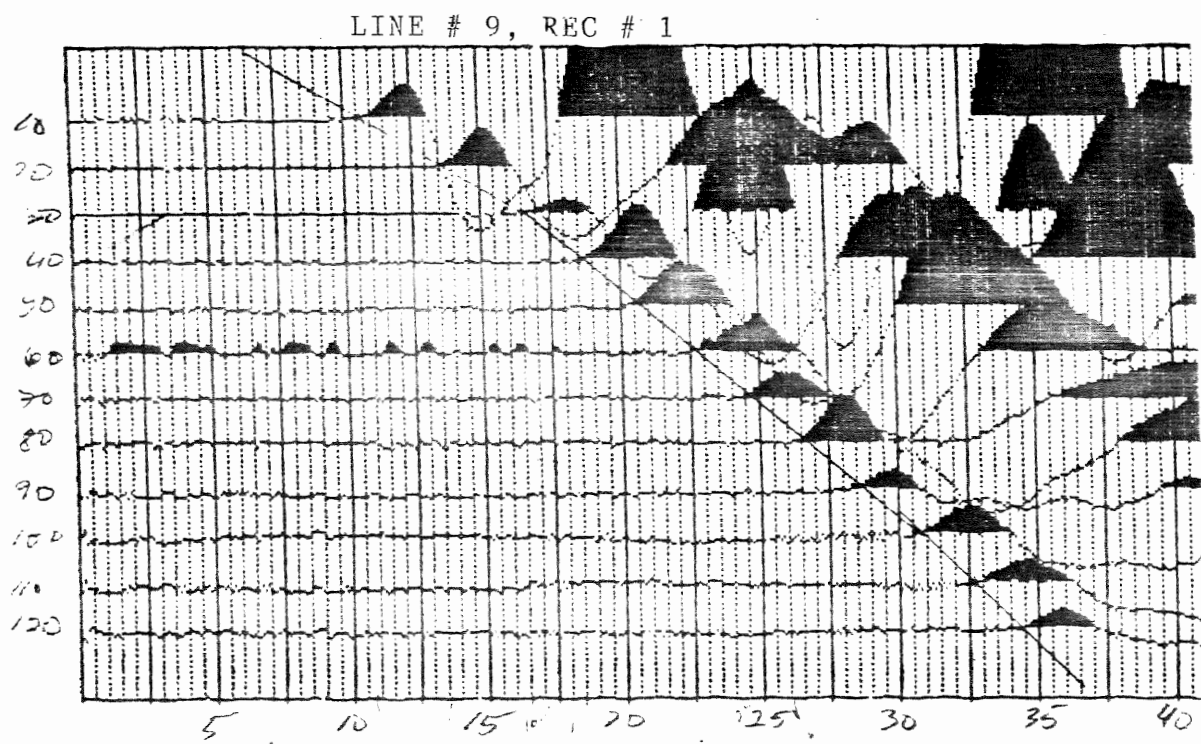

Figure #9. A typical seismic record used in this study, shown here to illustrate the error involved in picking.

Using graphical error methods this .5 msec error can be used to calculate errors in velocities (Figure #10). This is accomplished by averaging the highest and lowest reasonable slopes for both the updip velocity and the downdip velocity thus

LINE #7, V2u: ERROR CALCULATION

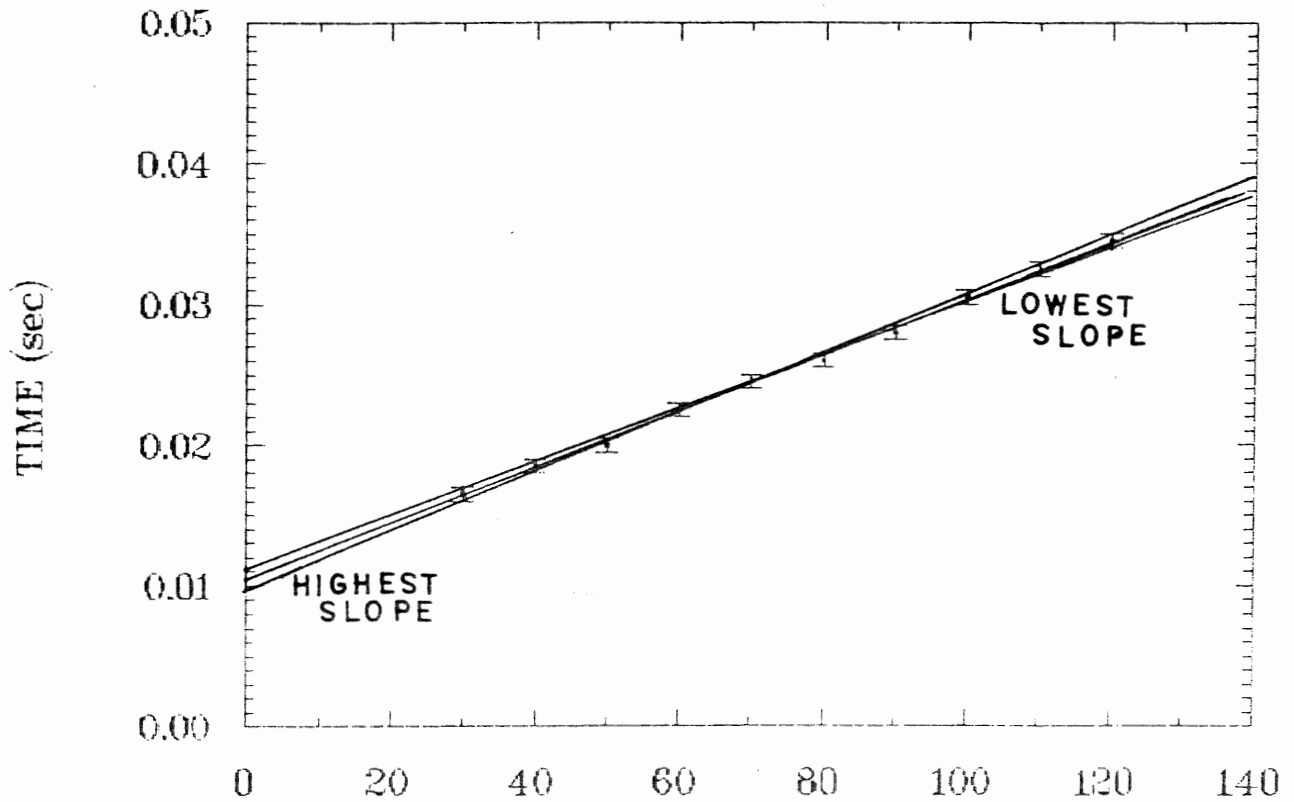

Figure #10. Illustration of graphical error method used.

obtaining the error in slope.

$$\text{error in slope} = \frac{1}{2} (\text{highest reasonable slope} - \text{lowest reasonable slope})$$

Thus the fewer the points defining a velocity and the higher the magnitude of the velocity the larger the error in the velocities. A higher velocity means that energy can travel much

farther in the $\pm .5$ msec error range, therefor giving a wider range of possible velocities. While the exact determination of V_1 is complicated, it can be approximated by $1/V_1 \sim 1/V_u + 1/V_o$. This approximation means that the error in V_1 can be estimated simply from the error in V_u and V_o using:

$$\delta V = \sqrt{(\delta V_u)^2 + (\delta V_o)^2}$$

The calculated errors for the thirteen lines are shown in Table #2. Other errors such as the irregular nature of the subsurface produces minor changes in the arrival time. Calculation of a model assumes horizontal homogeneity of the subsurface layer which due to different erosional patterns and variation in till depths is not the true case.

RESULTS:

Table #2 shows the results from the corrected data. The seismic survey indicate a 3 layer model whose average velocities are $V_o = 1725$ m/sec, $V_1 = 3500$ m/sec, and $V_2 = 5300$ m/sec. Although the calculated errors shown in Table #2 are relatively large for velocity determination, i.e. often on the order of ± 1000 m/sec, the range of velocity values calculated is well constrained.

V_o -- 1538 m/sec to 2000 m/sec

V_1 -- 2804 m/sec to 4860 m/sec

V_2 -- 4589 m/sec to 6032 m/sec

By comparing these velocities to average velocities

81

LINE #	BEARING	V (m/sec)			DIP OF AVE. DEPTH	DIP OF AVE. DEPTH	DIP OF AVE. DEPTH	
		1	2	3	1	BED OF 1	BED 2	BED TO 2
1	096	2000 ±400	4800 ±1300	-----	-05.5	13.8 m.	-----	-----
2	219	1500 ±050	3400 ±0400	6000 ±1100	+04.1	05.4 m.	-00.8	25.4 m.
3	358	-----	-----	-----	-----	-----	-----	-----
4	140	1500	4900 ±0600	5900 ±4400	+02.1	13.7 m.	-13.3	28.9 m.
5	176	1900(1)	3100 ±0300	5600 ±1700	+03.8	05.6 m.	-06.1	17.2 m.
6	206	1900 ±060	3800 ±1900	5200 ±1300	-01.6	08.6 m.	08.0	30.0 m.
7	314	1500(2)	3200 ±0700	4600 ±0300	-01.7	04.9 m.	00.3	16.2 m.
8	087	1900(1)	2800 ±0800	4800 ±1000	+15.5	14.4 m.	-00.5	(3)
9	120	1900(1)	3400 ±0700	5200 ±1500	-05.2	10.7 m.	05.0	21.7 m.
10	048	1700 ±050	2600 ±0600	5200 ±1600	+10.0	08.7 m.	-07.6	17.3 m.
11	265	1500(2)	3800 ±0700	5800 ±1400	-01.2	03.2 m.	04.1	18.5 m.
12	175	1500(4)	4300 ±0600	-----	+00.6	15.6 m.	-----	-----
13	167	1500(4)	4000 ±0600	4700 ±1900	+04.0	11.8 m.	-02.0	26.5 m.

TABLE #2:

Calculation of velocities, depths, and dips from the seismic records (Appendix A). Appendix B shows the calculations used in determining these values. (1), (2), and (4) have been taken from neighboring lines due to the difficulty in obtaining first breaks. The error in velocity because of this is negligible when compared to error from picking arrival times. (1) Velocity of till layer taken from Line #6. (2) Velocity of till layer taken from Line #2. (3) Unable to calculate depth to 2 bed; shown in Appendix A, Line #8. (4) Velocity of till layer taken from Line #4. Error in velocities are shown in the velocities column with a ±. The (-) for the dips indicates a dip 180 degrees from the bearing, while a (+) indicated a dip in the direction of the bearing given.

tabulated in The Handbook of Physical Constants a reasonable geologic model was constructed.

Glacial till has an average, saturated velocity of 1730 m/sec. This lies well within the range of values given for V_0 . The velocity of granite has a wide range of values but average about 5200 m/sec. Thus V_2 may represent the velocity of granitic rock. V_1 possibly represents a weathered granite or grus layer. Twidale (1982) notes weathering patterns of granite display a sharp contact or at most a narrow transition zone between weathered granitic material and fresh granite. This change in physical properties results in changes in seismic velocities which would be evident on the seismic profiles. V_1 could represent this weathered zone. The second layer averages 14.1 meters, with a range of 8.60 m to 20.05 m. Sten and Fowler (1979) note that due to the porous nature of the local till intense weathering of the subsurface can take place in Nova Scotia. Thus an average thickness of 14 meters may be realistic for a granite weathering zone. The variability of the velocity in this weathered zone i.e. ~2000 m/sec, is because weathering does not progress at a uniform rate, and its intensity will vary from one local to another. This means a large variation of densities and thus a large range of recorded velocities over a relatively small area.

Several of the refraction seismic lines were shot over the proposed location of metasediments i.e. Lines #7, #10, and #11. However the thickness of the second layer and its velocity do not vary substantially from thicknesses and velocities over the

granite. This evidence contradicts a weathered zone hypothesis as these two rock types - metasediments and granite - should weather at different rates.

LINE #12

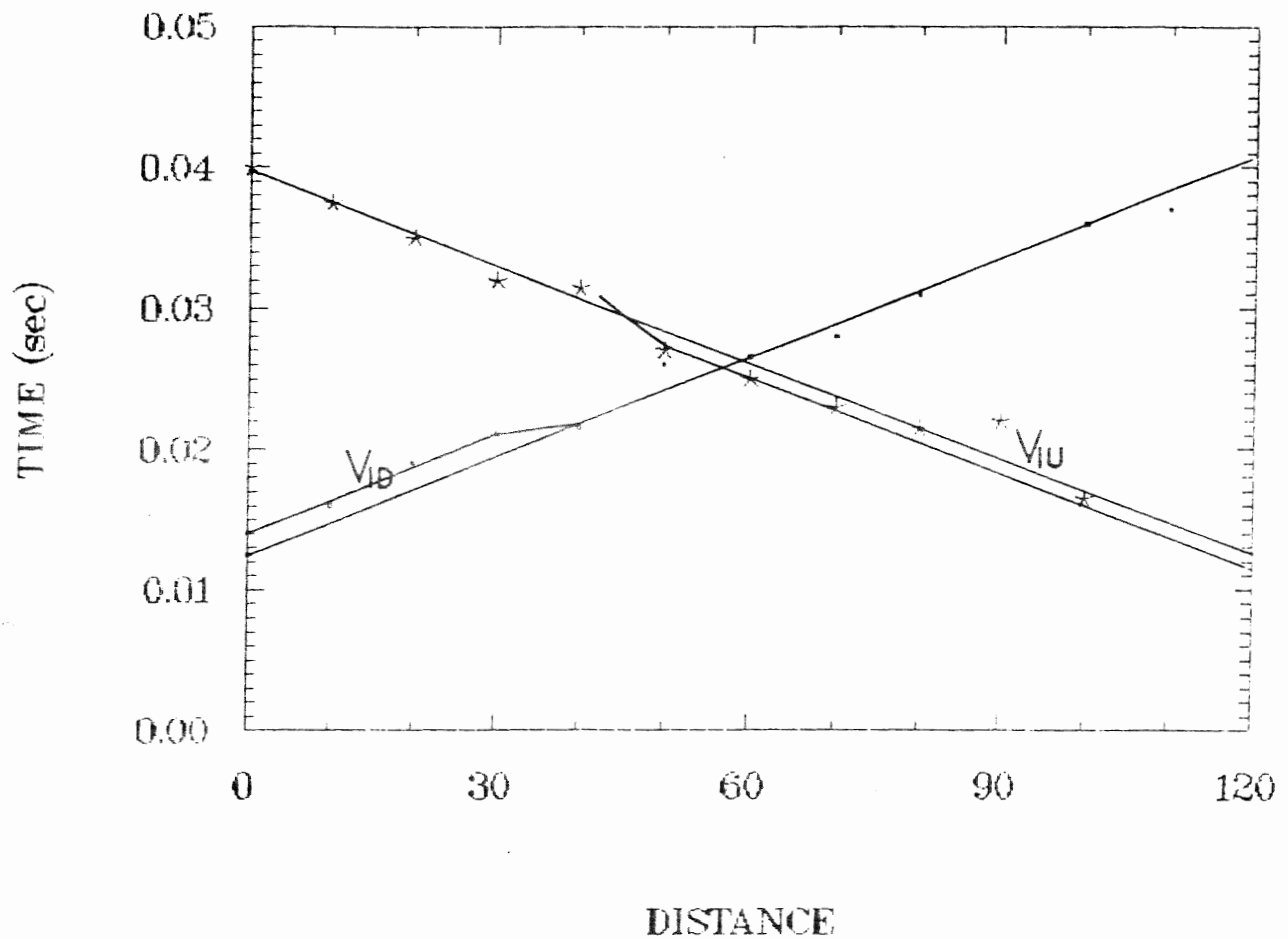

Figure #11. Illustrating a highly faulted surface.

The data also indicates a large number of faults cross-cutting both the weathered zone and the fresh granitic body.

Figure #11 (similar faults can be seen in the time - distance

graphs in Appendix B) shows the effect a fault will have on the arrival times. The throw direction and height can be easily determined using the following equation (Dobrin and Savit, 1988).

$$(T2a - T2b) * V2 = \text{throw of fault in layer two}$$

This supports the model of a weathered and fractured intermediate layer - V1. Typical throws of these fractures are 3 - 5 meters.

The dips of the refracted layers are relatively shallow as one would expect on the top of a pluton. Also since each seismic line examines such a small area of surface, that the measured dips may reflect only minor undulations of the pluton's surface due to erosion.

The large error in calculated velocities and the fact that the velocities of metasediments are close to those of granites, i.e. ~ 5700 m/sec (Handbook of Physical Properties of Rocks, 1982), means that while mapping of the subsurface is possible differentiating between the metasediments and the granite is not.

CONSEQUENCES FOR GRAVITY:

Brogan's (1988) gravity modeling of the Liscomb Satellite pluton assumed that the gravity meter sat on the granite pluton during the field measurements. The seismic data disproves this assumption by quantifying the thickness of a till layer on top of the pluton. The low density till layer has an affect on the gravity data, but whether this effect is of any substantial

LINE #	GRAVITY VALUES	TILL THICKNESS	CORR.(1) FOR TILL	CORR.(2) FOR GRANITE	TOTAL(3) CORRECTION	B.S CORR.- GRAV. CORR.	CORRECT GRAVITY
1			NOT NEAR A GRAVITY STATION				
2			NOT NEAR A GRAVITY STATION				
3			NO DATA				
4	6.85	13.66	2.64	0.00	2.64	+ .06	6.91
5	6.38	05.61	1.26	1.19	2.45	- .20	6.18
6	5.64	08.60	1.93	0.61	2.54	- .10	5.54
7	8.67	04.84	1.09	1.33	2.42	- .22	8.54
8			NOT NEAR A GRAVITY STATION				
9	5.08	10.71	2.41	0.20	2.61	- .03	5.05
10	9.45	08.71	1.96	0.59	2.55	- .10	9.35
11	8.73	03.15	0.71	1.66	2.37	- .27	8.46
12	6.49	10.57	2.38	0.23	2.61	- .04	6.45
13	0.00	11.76	2.64	0.00	2.64	.00	0.00

TABLE #3:

Calculation of the effects the overlying till layer has on the gravity value from Brogan (1988). All gravity values and corrections are in milligals. Till thickness is in meters. (1) correction for the till = till thickness * .2248 mgals (2) correction for granite = (base station till thickness - till thickness) * .1930 mgal (3) total correction = till correction + granite correction.

consequence to the model produced by Brogan (1988) must be determined.

By stripping the effect of the till layer off the Bouguer gravity values a more accurate model of the pluton can be constructed. This stripping is done mathematically by correcting for the presence of till under the base station, then subtracting this correction from the till correction made to the gravity values at stations where the till thickness is known. The correction to the base station is

$$B \text{ grav corr} = B \text{ grav} + FA \text{ corr} - B \text{ corr}$$

The correction for free air (FA corr) is .3086 mgal/meter, while the correction for bouguer (B corr) is .0419 mgal/meter with the density of till equal to 2.00 g/cc. Thus .2248 mgals must be added to the gravity values for every meter of till.

The new datum plane is the elevation of the granitic body under the base station i.e. the ground elevation - the thickness of till. The gravity stations must therefor be corrected relative to this new datum plane. The correction to the gravity value is the addition of .2248 mgals per meter of till above the datum plane plus .193 (from Brogan, 1988) mgals per meter of granite above the datum plane. Table #3 shows these correction and the Bouguer gravity relative to the base station. Only gravity values near seismic line are corrected because the till thickness at that location is known.

The maximum correction applied to the gravity values listed

in Table #3 is .274 mgals, thus although the gravitational stripping of the till layer from the gravity values produces a smaller anomaly, the magnitude of that change is relatively small. Corrections made to stations which lie on top of till thickness which is close to the till thickness under the base station are very small i.e. .0336 mgal. However since the pluton has been mapped using geology, some outcrop should exist. Such outcrop would mean an error of .375 mgals on the gravity values. Therefor it can be seen that the uncertainties caused by an inadequate knowledge of till thickness within the range measured will not have a major effect on the Bouguer gravity contours

Further correction may have to be applied due to the weathered zone. However since the density contrast between the weathered granite and the granite is less than that between the till and the granite, the corrections needed in order to subtract the effect of the grus will be much smaller than the corrections for the till layer shown on Table #3.

GRAVITY MODELING:

The previous section showed that the thickness and variation of the till layer - determined by seismic refraction - over the pluton does not affect the gravity data by a significant amount. However this conclusion is important as it places a constraining parameter for the remodeling of the data. Brogan (1988) matched the observed gravity data by varying three quantities; horizontal extent of the individual blocks, density contrast between the Satellite Pluton, the Main Liscomb Complex,

and the surrounding host, metasedimentary rocks, and by varying the depths to the tops of the blocks. This third parameter - depth to the tops - has now been determined by seismic refraction profiling and because the depth of the blocks i.e. the thickness of the till, does not alter the gravity data by any significant amount the modeling of the pluton should be done by varying only the horizontal extent of the blocks and/or by varying the density contrasts between the three rock types.

Remodeling of Brogan's (1988) gravity data was undertaken with a number of objectives in mind.

1. To re-examine the minimum depth for a possible contact between the Satellite Pluton and the Main Liscomb Pluton.
2. To examine the effect the deeper mass of the bodies have on the gravity values measured at the surface and to determine a minimum depth for both the Satellite Pluton and the Main Liscomb Complex.
3. To determine the gravitational effects from the Main Liscomb Complex on the gravitational signature of the Satellite Pluton.
4. To simplify the model proposed by Brogan (1988), i.e. modeling the pluton with the fewest number of blocks possible while still approximating the observed gravity.

One must remember that while the error in the gravity values is very small $\pm .05$ mgals (Brogan, 1988), the error due to the sparsity of gravity measurements over large parts of the study area results in a much larger error in the observed gravity contours than $\pm .05$ mgals. Brogan contoured the observed gravity data from 96 stations over an area of 22 km (for the distribution

of station see Brogan, 1988). Therefor modeling of the Pluton should be with as few blocks as possible because the accuracy of the survey does not warrant the fine subdivision of Brogan's (1988) model. Reduction of the number of blocks used for the model in no way diminishes the importance or accuracy of the results.

Before modeling with the 3 dimensional program Threed was undertaken some constrains on the input parameters - density contrast, block location, and depth to the top and bottom - were determined by examining the geology of the area, and the physical characteristic of the rock types. Remodeling of Brogan's (1988) data was done solely using the 3 dimensional program because the calculated data can be contoured and compared to the observed data.

CONSTRAINTS ON MODELING:

(i) Density contrasts - Douma (1978) determined that the average density of the meguma metasediments is 2.73 g/cm³, while the density of granitic rocks in Nova Scotia is 2.64 g/cm³. Thus the density contrast used in modeling should be ~ -.09g/cm³. However Douma's values are only averages for the rocks and thus act only as a guide for the density contrasts used.

(ii) Depth of blocks - the effect from the till layer on the gravity value is fairly small and thus ~~for all intensive purposes~~ ^{will} can be ignored. Variation of the depths to the top of the blocks will be limited because a relative uniform depth to the top is expected. Previous geological mapping of the Liscomb

Pluton (Bujak, et al., 1980) is an indication that part of the pluton must be outcropping. The boundaries of the pluton shown in Figure #1 correspond to a 1.5 mgal low - Figure #2. Thus the blocks near the Main Liscomb Complex should outcrop, while blocks further north should be at a deeper but more uniform depth.

(iii) Gravity signature of Main Liscomb Complex - The Main Liscomb Complex has been extensively mapped (Giles and Chatterjee, 1987). Thus the initial blocks that are input should closely mimic the outcropping granitic bodies of the Complex. However, the gravitational anomaly calculated using the Threed program does not match the observed gravity over this southern section of the study area. Thus it was assumed that underlying the high grade gneisses and schists in the southeastern area is a low density body i.e. part of the Main

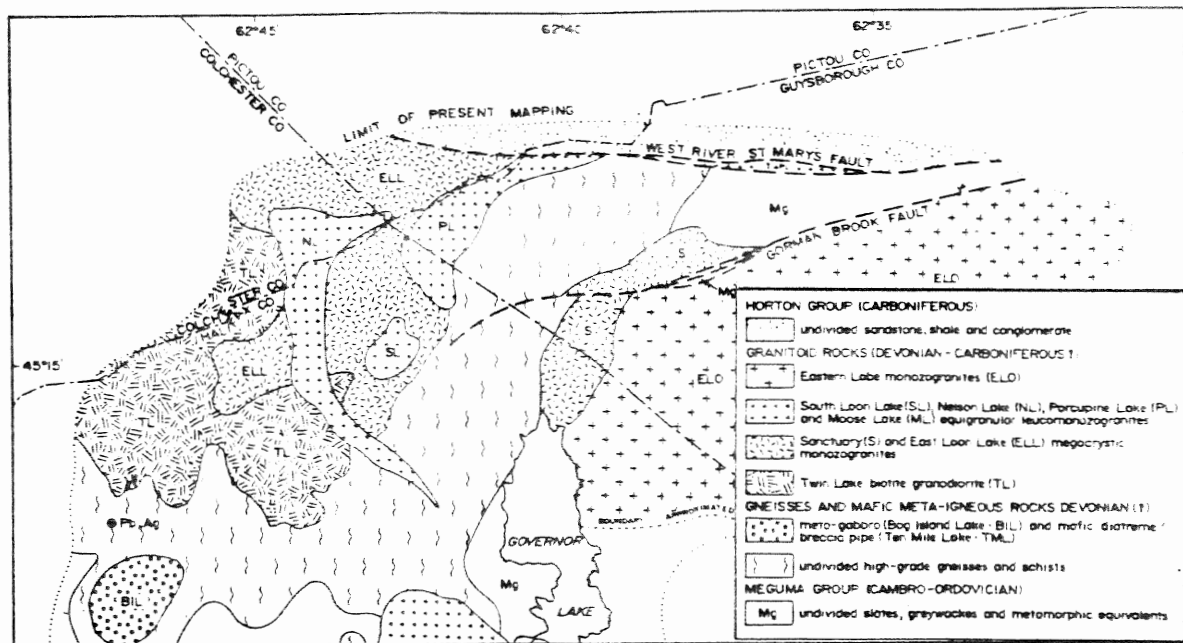

Figure # 12. Showing the present day mapping of the Main Liscomb Complex after Giles and Chatterjee, 1987.

Liscomb Complex (Figure #1). Thus the gneisses and schists can be considered as a possible roof pendant. This assumption is substantiated because the geology of the area (Figure #12) shows; the outcropping of monzogranite (mapped by Giles and Chatterjee, 1987) on either side of the schist, and the extension of the N.L. leucomonzogranite 2.5 km into the schist, suggesting the erosion of the overlying schist.

(iv) Gravity high between the Satellite Pluton and the Main Liscomb Pluton - The observed high gravity in the area between the Satellite Pluton and the Main Liscomb Complex suggests that no connection exists between the two bodies (Figure #2).

GRAVITY RESULTS:

(i) With the above mentioned constraints on the input parameters a best fit model was generated. Table #4 shows the prism parameters used in the model (For an explanation of the x, y coordinates or a description of the program see Nagy, 1966).

NO	BLOCK	COORDINATES OF CORNER POINTS				DEPTH	TOP	DENSITY
		X1	X2	Y1	Y2			
1	10	-2000.0	6500.0	5400.0	13000.0	10000.0	.0	-1.10
2	20	-2000.0	5750.0	4000.0	5400.0	10000.0	.0	-1.10
3	30	-2000.0	3000.0	3000.0	4000.0	10000.0	.0	-1.10
4	40	-2000.0	2250.0	1500.0	3000.0	10000.0	.0	-1.11
5	50	-2000.0	1500.0	.0	1500.0	10000.0	.0	-1.10
6	60	5750.0	6750.0	250.0	530.0	10000.0	40.0	-1.00
7	70	5750.0	6750.0	700.0	1500.0	10000.0	.0	-1.05
8	80	6750.0	8250.0	-1100.0	1500.0	10000.0	40.0	-1.00
9	90	5750.0	7000.0	1500.0	3000.0	10000.0	.0	-1.00
10	100	7000.0	8250.0	1500.0	3000.0	10000.0	40.0	-1.00
11	110	6500.0	7200.0	3000.0	4000.0	10000.0	.0	-1.00
12	120	7200.0	8250.0	3000.0	5500.0	10000.0	40.0	-1.00
13	130	6750.0	7200.0	4000.0	5250.0	10000.0	.0	-1.05
14	140	8250.0	9000.0	-2500.0	4500.0	10000.0	40.0	-1.00
15	150	7250.0	8250.0	-1750.0	1000.0	10000.0	40.0	-1.00

Table #4. Showing the size, depth, and density of the blocks used to model the Pluton.

Block #1 - #5 approximate the Main Liscomb Complex. These blocks are assumed to be outcropping (depth to top = 0.00). This assumption is necessary for the matching of the gravity values over the Complex. To further constrain the model the location of blocks #1 - #5 were not changed during the modeling process. Only in the density contrast was variation allowed to occur.

Blocks #6 - #15 made up the Liscomb Satellite Pluton. Thus modeling of the pluton was accomplished using only 10 blocks.

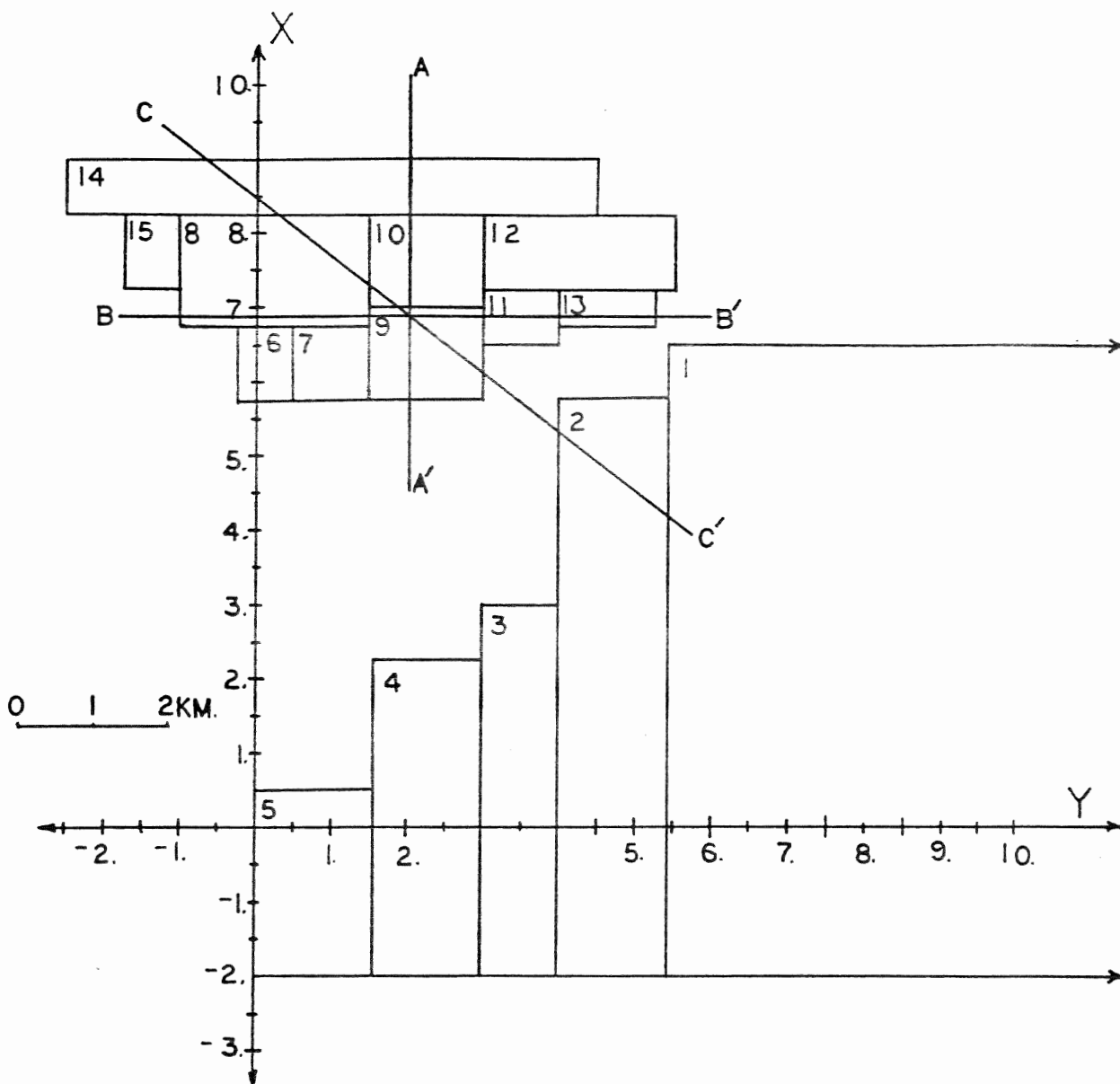

Figure #13. Updated 3-D block model.

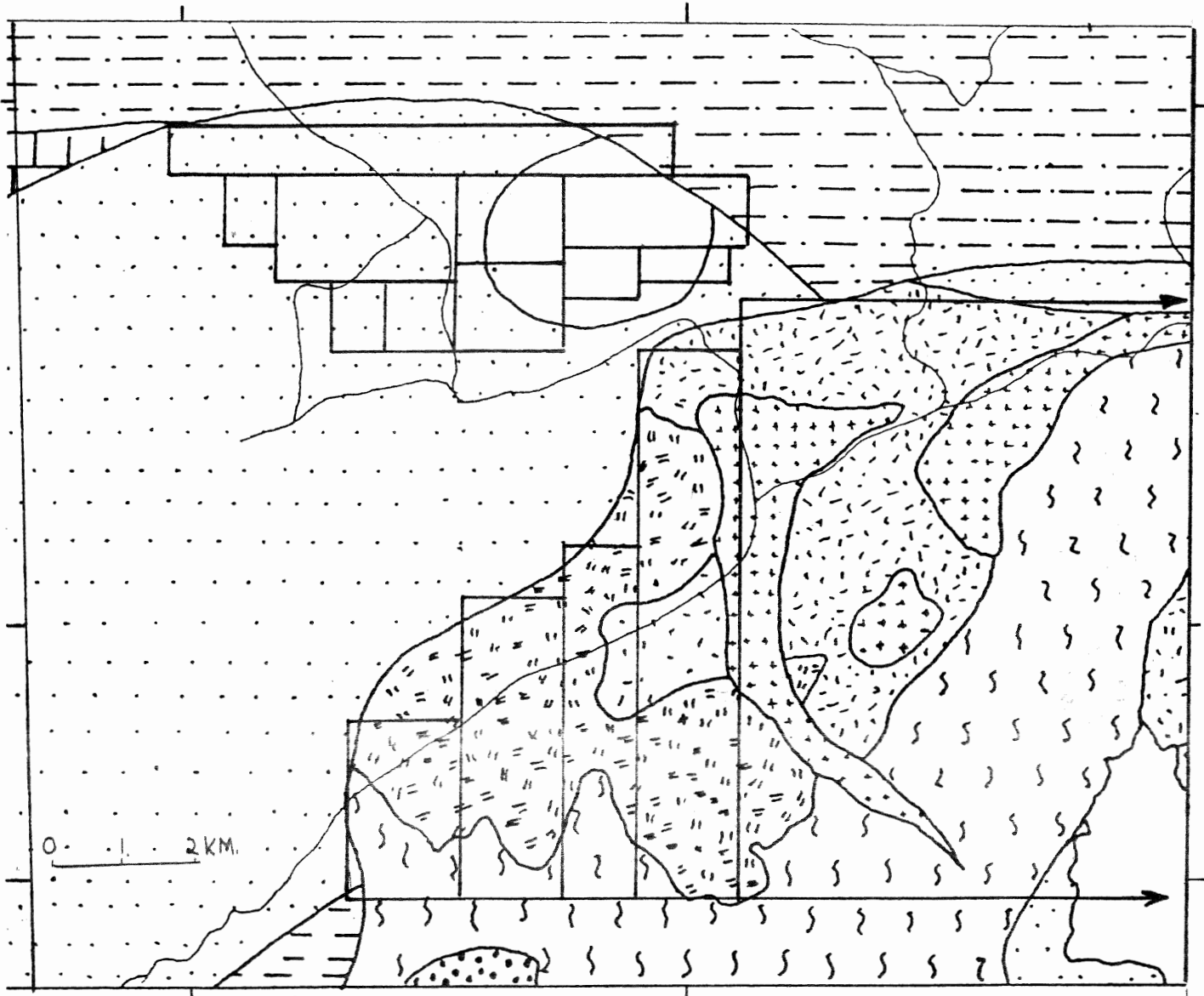

Figure #14. Geographical location of pluton.

The depths to the top of these blocks vary from 0.00 in the south to 40.0 meters in the north and to the west. Figure #13 shows the location of blocks #1-#15 in an X-Y coordinate system. While Figure #14 shows the location of these blocks in relation to the geology of the area.

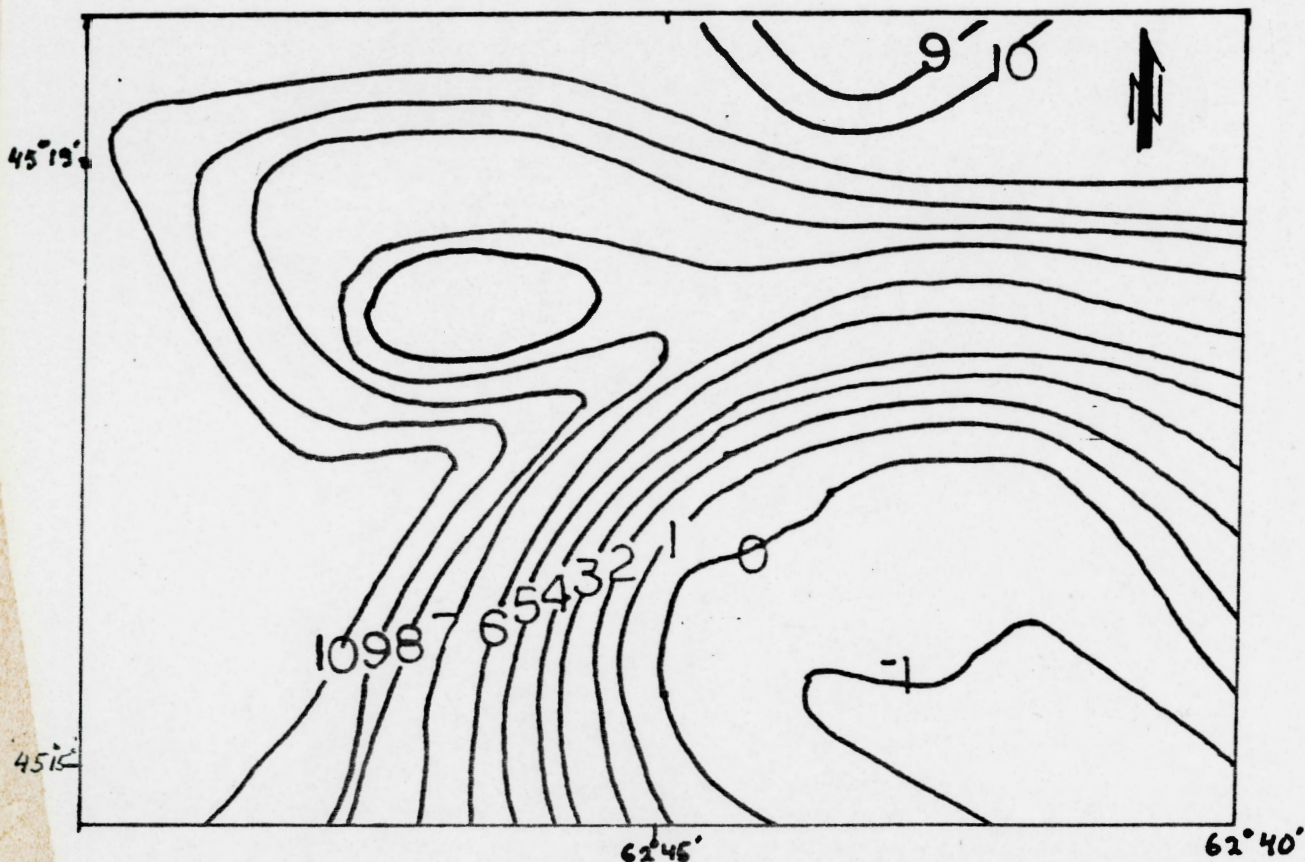
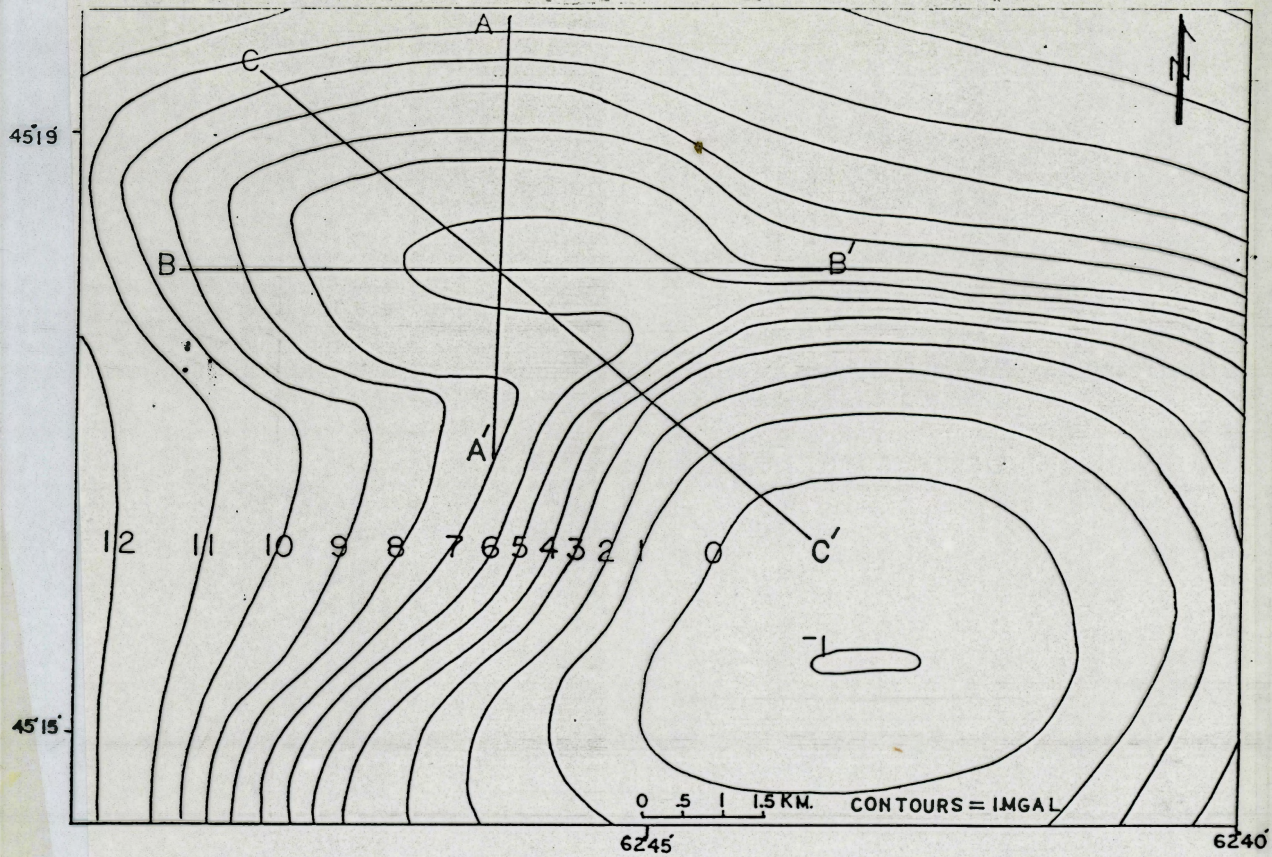

Figure #15 . Comparison of calculated and observed data for the remodeled data.

Figure #15 compares the observed Bouguer gravity value and the calculated values. The final model shows an elliptical body with an east - west length of 7 km and a north - south width of 3 km. Profiles A-A , B-B , and C-C (Figures #16, #17, and #18 respectively) show a pluton with steeply dipping sides i.e. near vertical, and a horizontal top. The only significant change in the depth to the surface of the pluton is evident between the northern and southern blocks of the pluton. The southern blocks - those closest to the Main Liscomb Complex - are shown to outcrop while



Print as transparency and overlay previous page.
Align with punched hole.

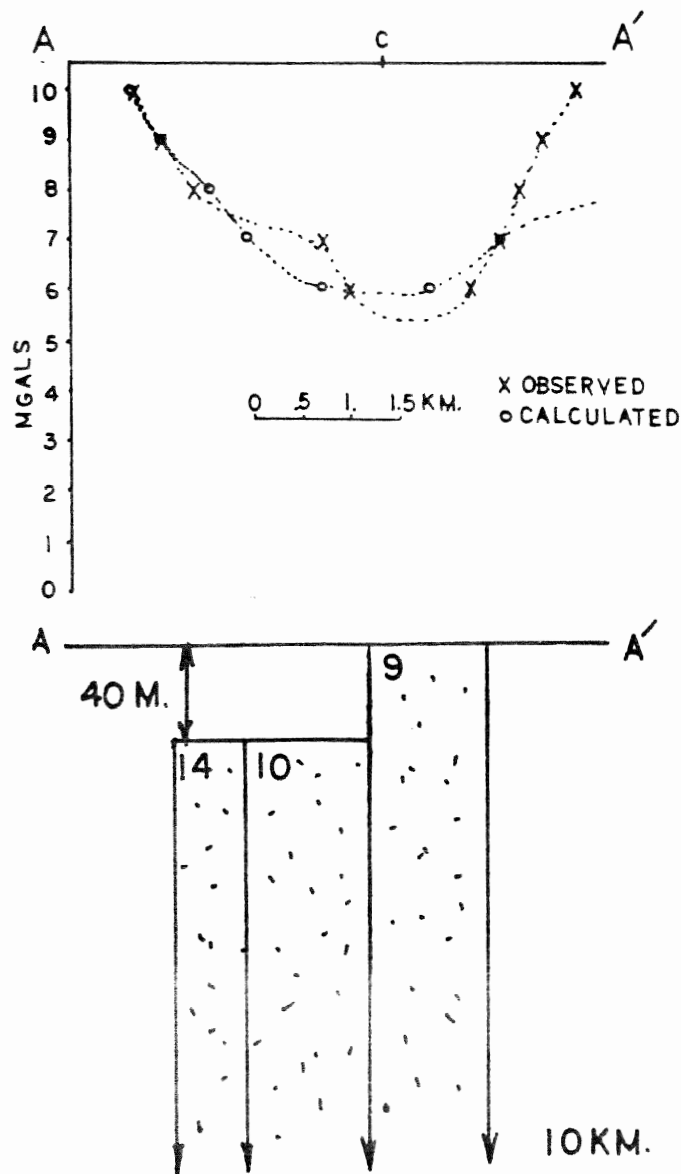

Figure 16. Profile A-A'

those to the north and the west are at a depth of 40 meters. This variation of depth was necessary for the matching of the 1.5 mgal low on the southern edge of the gravity anomaly while maintaining the more gentle gravity contours to the north. The vertical depth of the pluton is at a minimum of 10 km.

Profile A-A , which trends north - south across the pluton (Figure #16), shows good agreement between the observed and calculated gravity values along the northern portion of the profile, however there is disagreement at the southern end of the

profile. The calculated gravity values are on the order of 3 mgals less than the observed values. This offset may be because of the initial constraints placed on the blocks used for the modeling of the Main Liscomb Complex i.e. the x - y positions of the blocks and/or the density contrast of the blocks representing the northern portion of the Main Liscomb Complex (Blocks #1-#5).

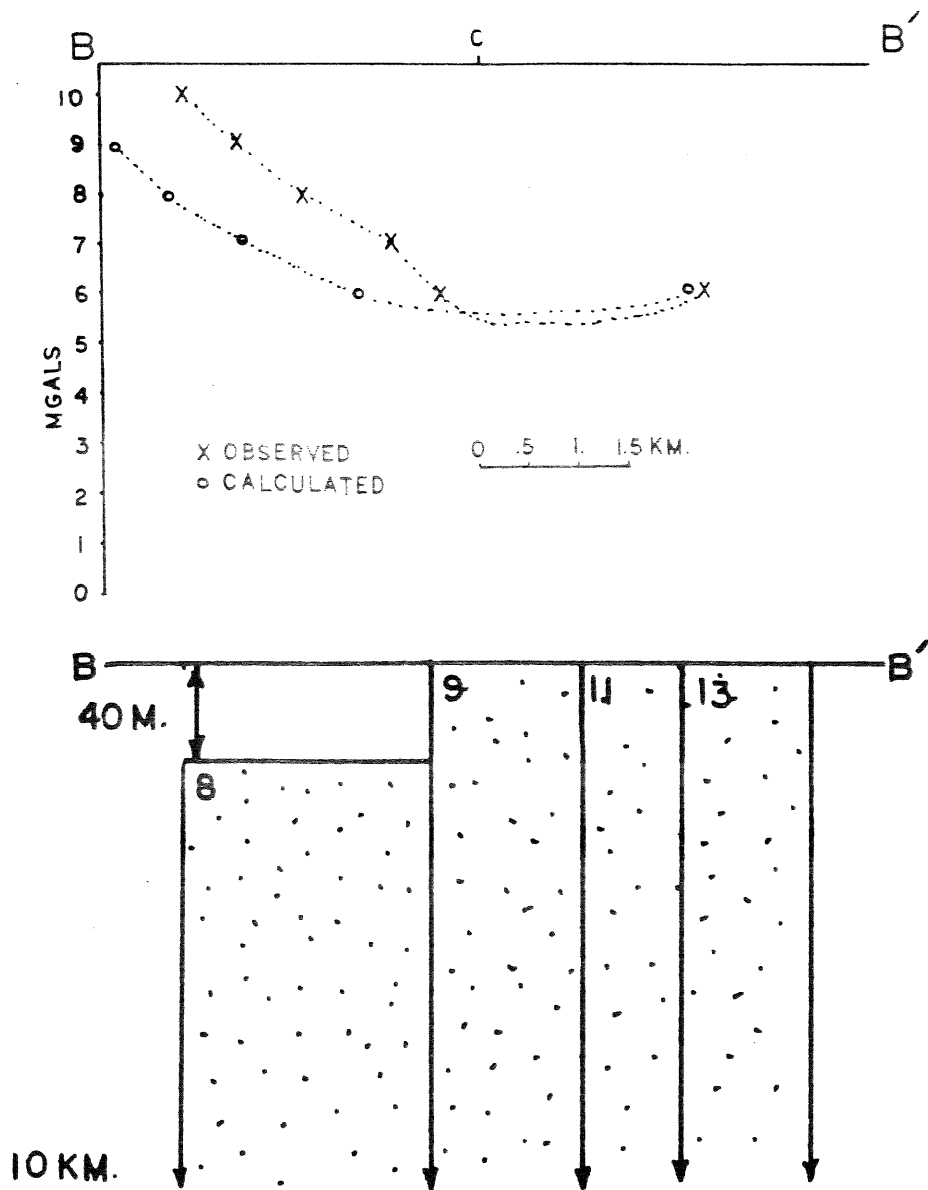

Figure #17. Profile B-B'

Profile B-B trends west - east across the pluton. The calculated and observed gravity value show similar trends i.e. a gravity low over the pluton (Figure #17). However in the western section of the profile the calculated gravity is ~ 1.5 mgals lower than the observed gravity. This disagreement may be as a result of a denser body of rock to the west of the study area, which would increase the observed gravity. The validity of this assumption can be established through future gravity work to the west of the Satellite Pluton. Both calculated and observed gravity are equal over the 1.5 mgal gravity low to the east.

Profile C-C, which trends diagonally over the pluton (northwest - southeast), examines both the Satellite Pluton and the Main Liscomb Complex (Figure #18). The calculated and observed gravity values are in agreement over the Satellite Pluton and both values decrease towards the southeast, however the calculated values begin to decrease before the observed values.

Profile C-C, as does profile A-A suggest that the blocks which approximates the Main Liscomb Pluton are either placed too close the Satellite Pluton or the northern granites have a higher density than the granites to the south. Both hypothesis will effectively decreases the calculated gravity. However the placement of blocks #1 - #5 was done after examination of the geology of the area - and the placement of the blocks to the north are situated only on outcrops of granite. Assuming that the placement of the blocks are correct, a lower density contrast for the northern section of the Main Liscomb Complex seems to be

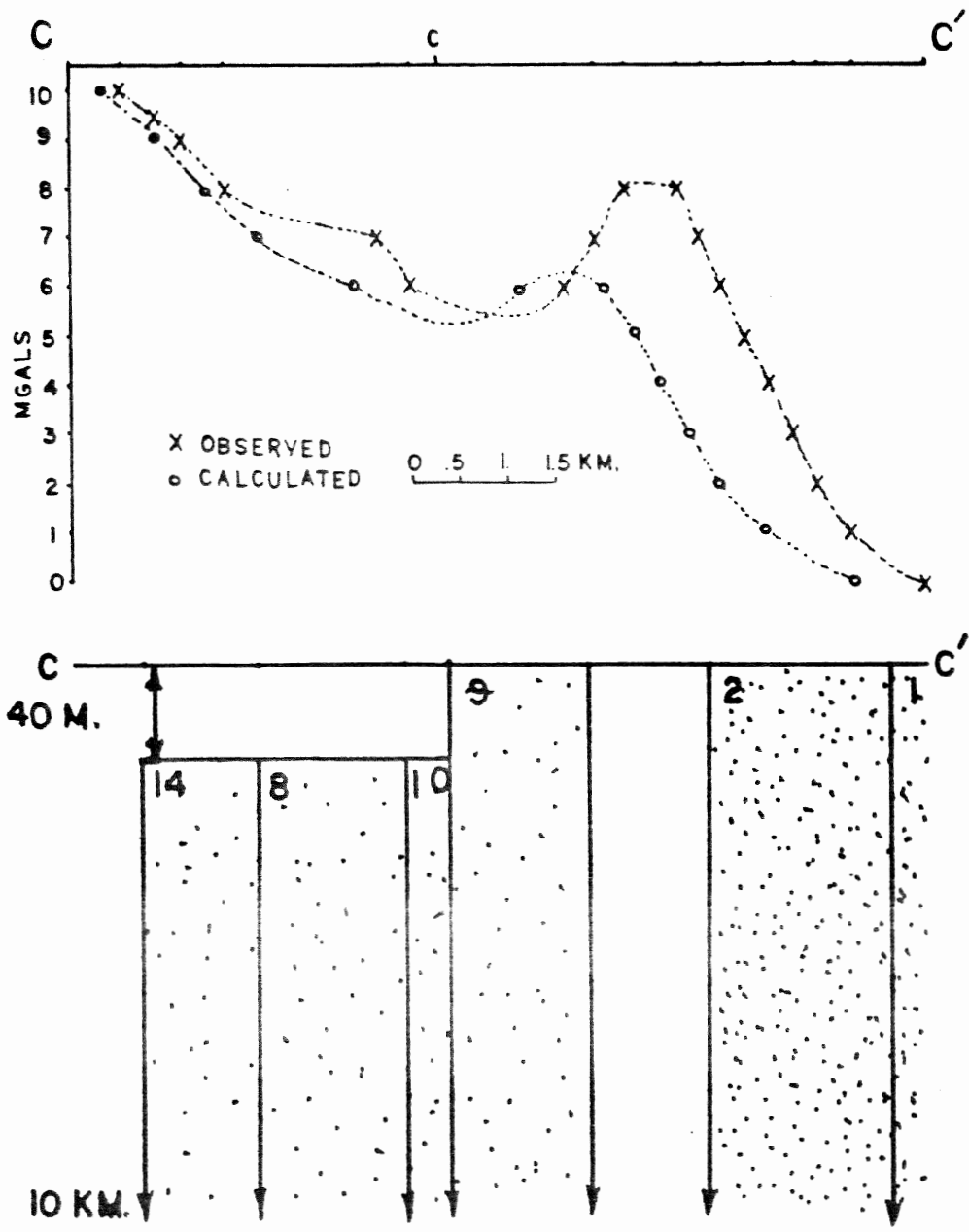

Figure #18. Profile C-C'

the most reasonable explanation for the disagreement between the observed and calculated values. This assumption that the Main Liscomb Pluton is composed of a variety of densities may be correct because the Main Liscomb Complex is made up of a variety of rock types - Figure #12 - each possibly having a different density.

(ii) Determination of the depth extent for the Pluton: The minimum depth to the bottom of the Satellite Pluton and the Main Liscomb Complex was determined by examination of the gravitational effect of the bodies at certain depth ranges. Brogan (1988) suggested a minimum depth of 20 km. This suggestion is not valid. Figure #19 shows the gravity signature calculated from the blocks used in the best fit model (Figure #13), for the interval of 10 - 20 km.

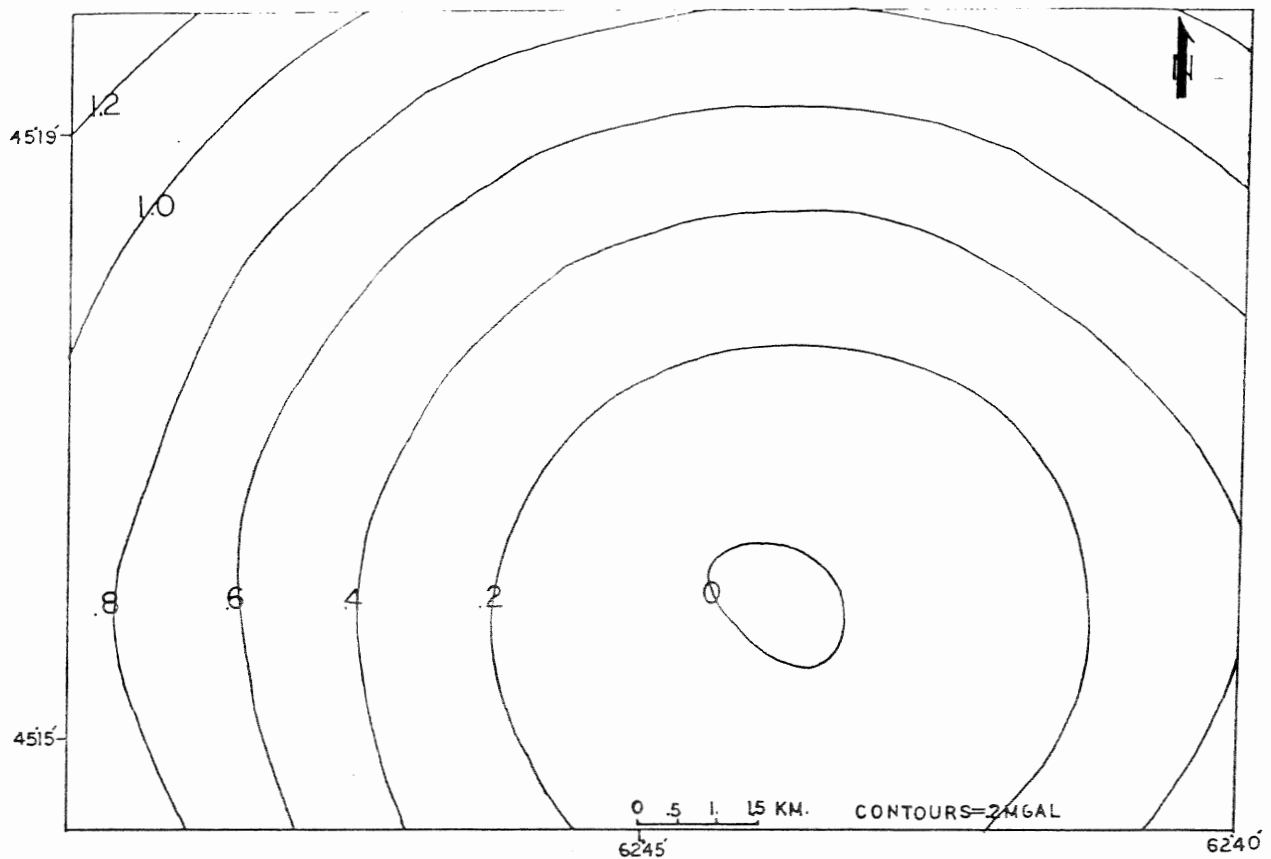

Figure #19. Bouguer gravity values from depth

Only the gravitational effect from the Main Liscomb Complex is evident and the effect from the Main Liscomb Complex is only ~1.0 mgals, over an area of 10 km. Thus the gravitational effect from a mass below 10 km is negligible in the data calculations. Therefore depth to the bottom of the plutonic body need be no more than 10 km.

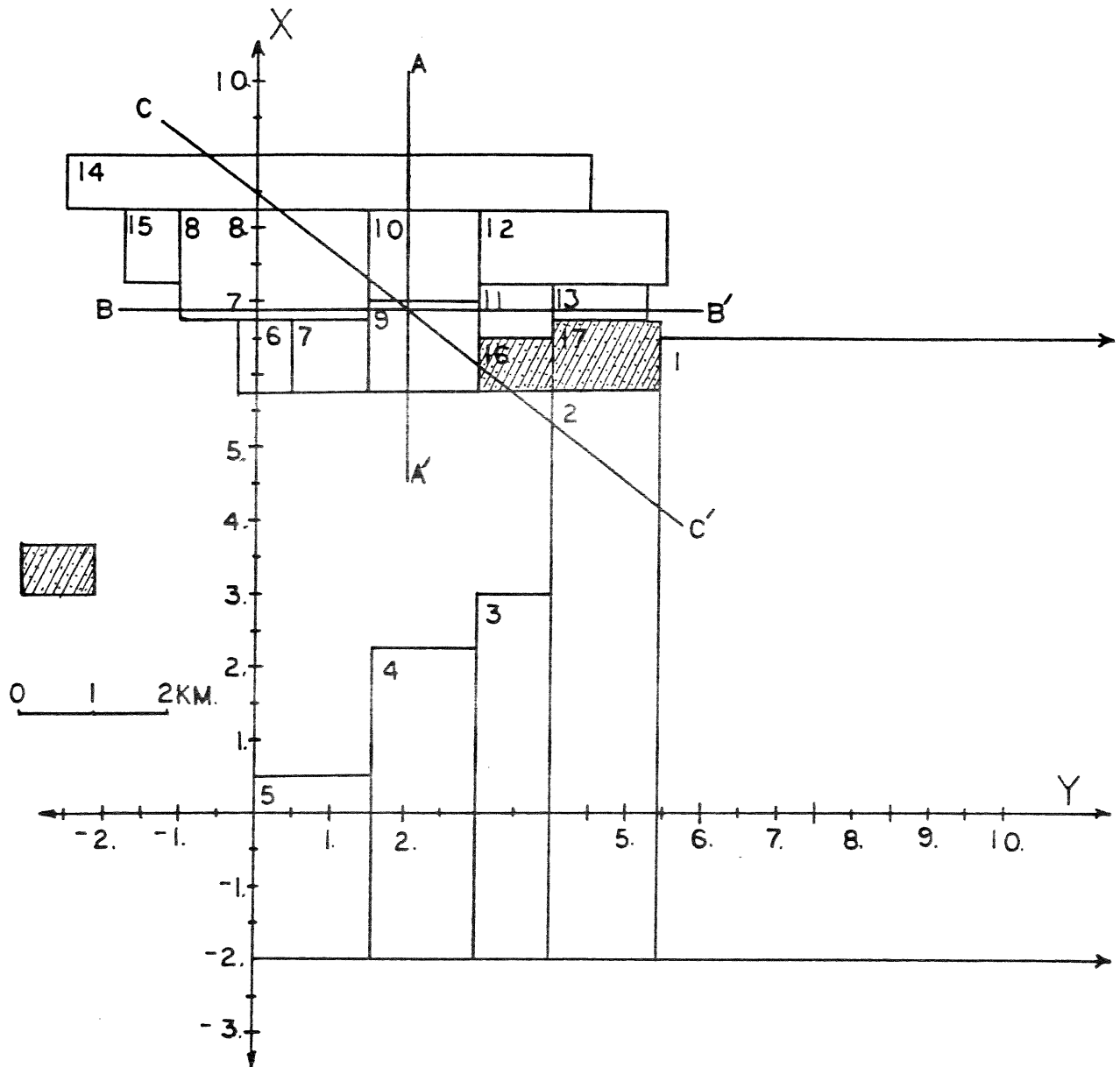

Figure #20. 3D model using contact blocks.

(iii) Determination of a possible depth to a contact between the Liscomb Satellite Pluton and the Main Liscomb complex: Brogan through his modelling (1988) suggested a minimum depth to a contact at 500 meters. However because remodelling of the data uses different density contrasts, block locations, and depths it should produce a different minimum depth to the contact. Blocks #16 and #17 which connect the two bodies (Figure #20) were input into the best fit model.

Examination of the gravity field associated with these two extra blocks at different depths allowed for the determination of a minimum depth of a possible contact.

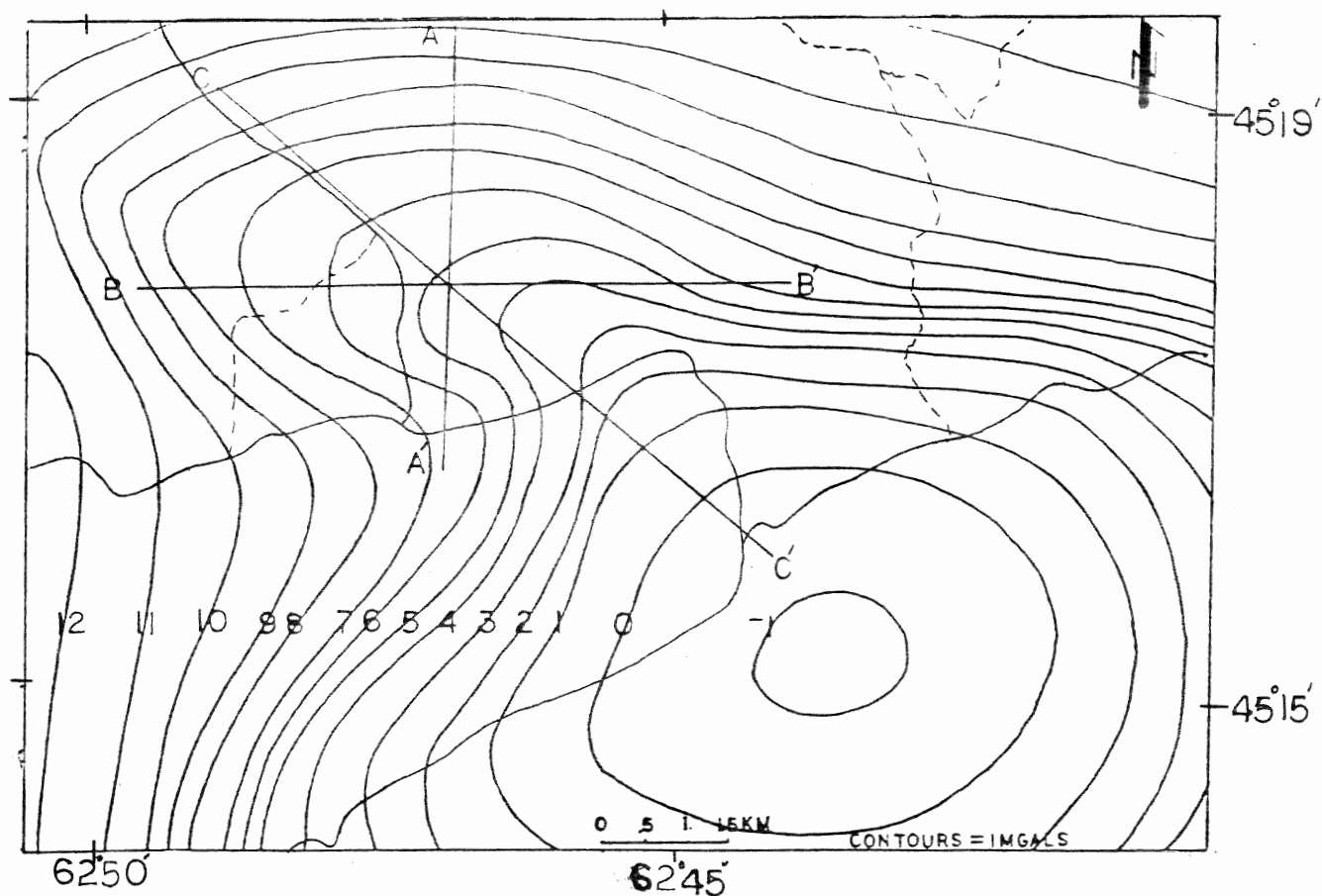

Figure #21 Contour map of calculated gravity: contact model.

Initial modeling assumed a possible surface connection between the two intrusive bodies (Figure #21). The contoured calculated data clearly does not match the observed data.

Profile C-C best illustrates this difference (Figure #24), and although both values decrease towards the southern end of the profile, the calculated values are 5 mgals less than the observed data. Profiles A-A and B-B (Figure #22 and #23

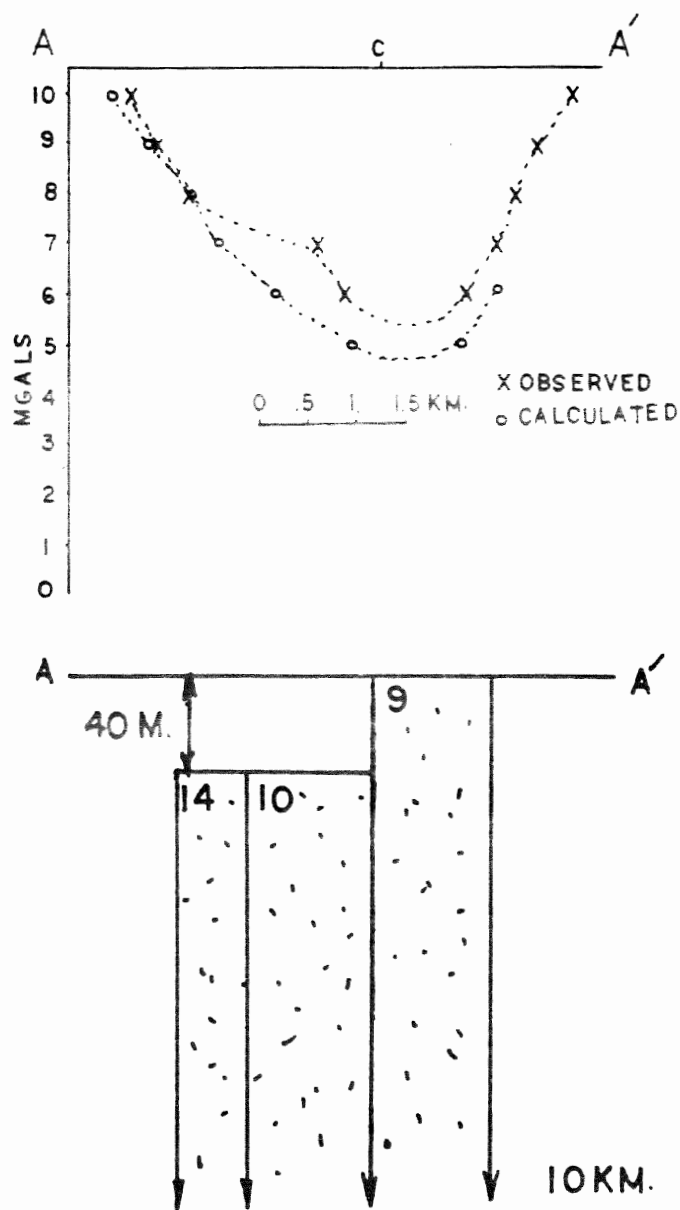

Figure #22 Profile A-A'.

respectively) show good agreement between the calculated and the observed data, however the match is less accurate than similar profile of observed and calculated data with out a contact (Figures #16 and #17).

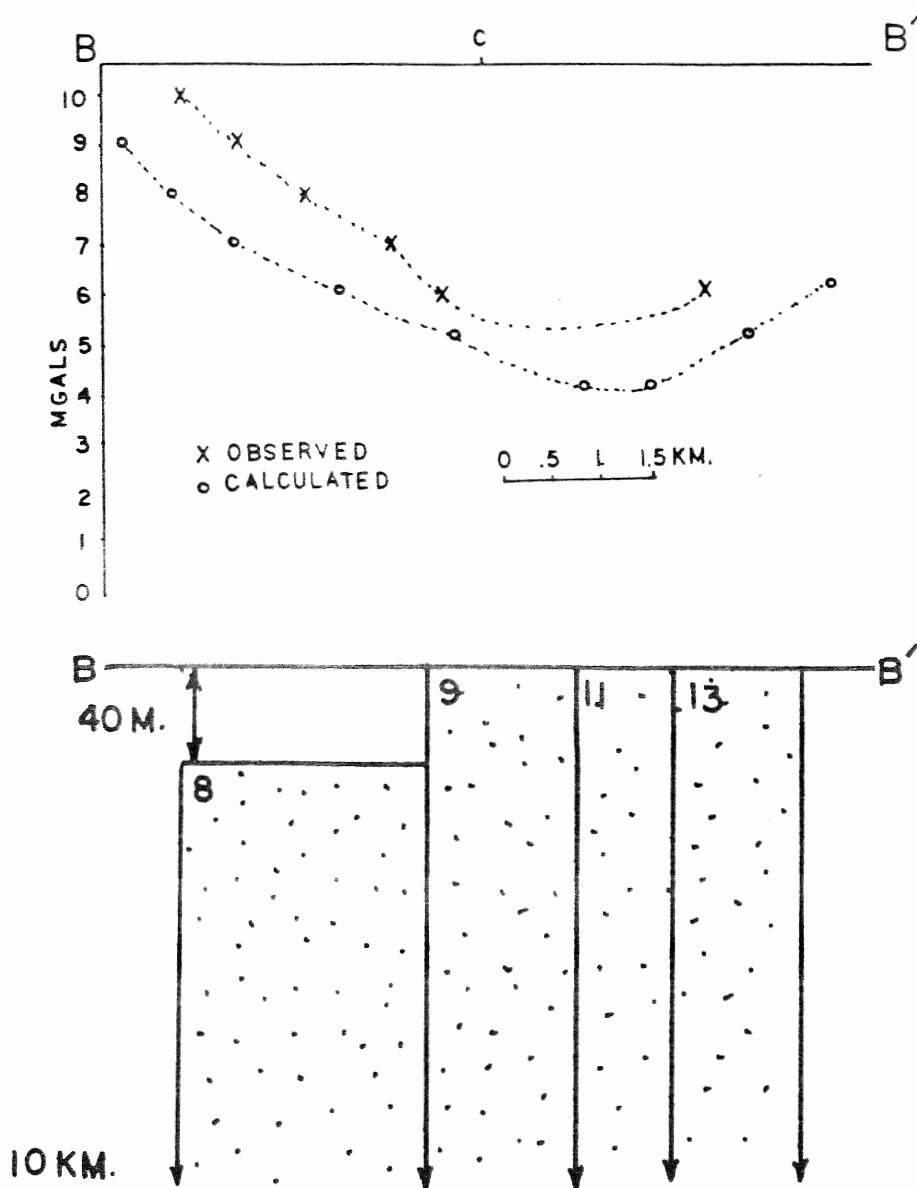

Figure #23. Profile B-B'.

Thus while there is no surface contact between the bodies, modeling shows that a possible connection at a depth greater than 1.0 km is possible. The gravity effect of a connection at depths greater than 1.0 km become insignificant at the surface i.e. within the data error.

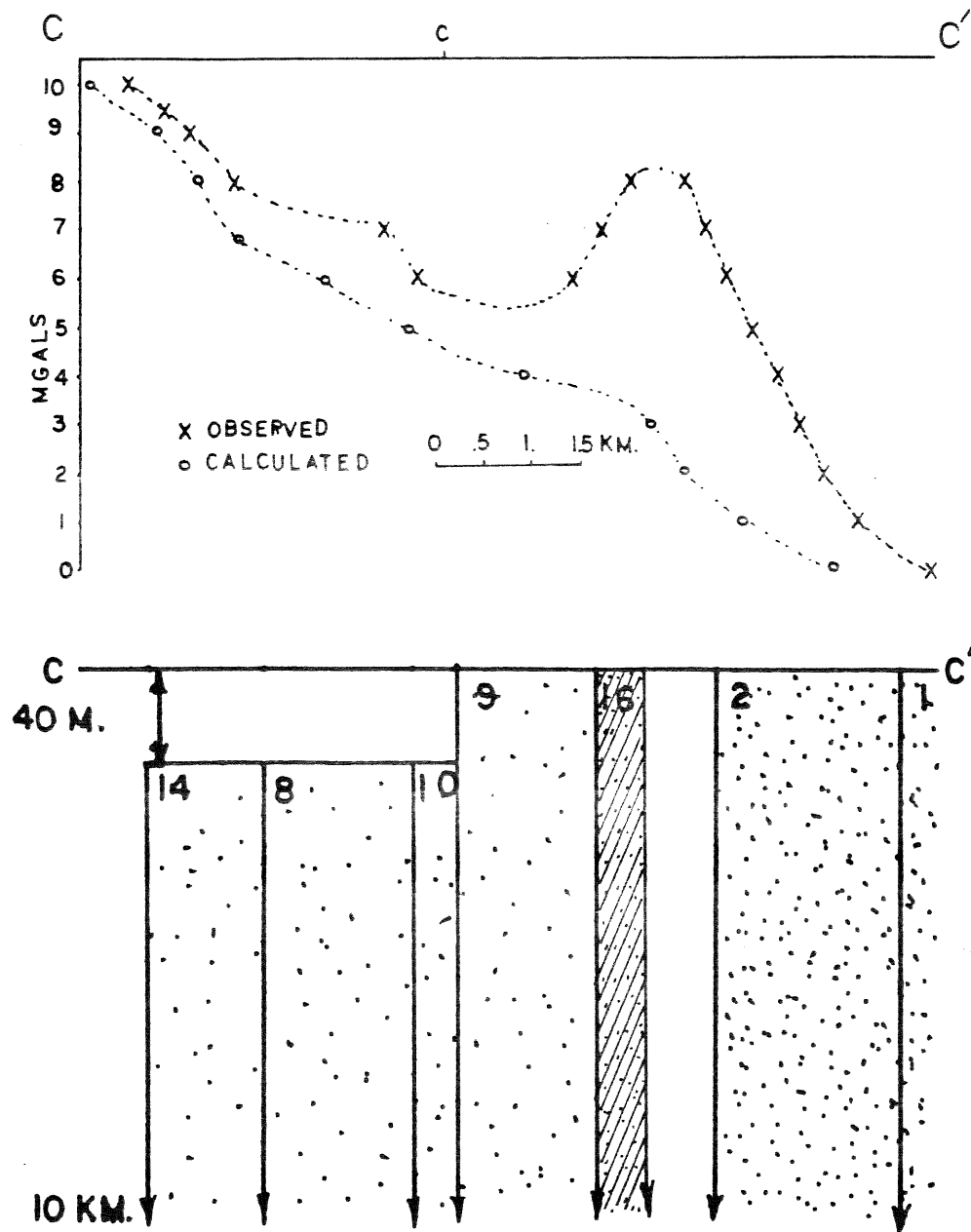

Figure #24. Profile C-C'.

DISCUSSION:

Gravitational modeling is an important tool for subsurface mapping of bodies at depth. The accuracy of the model produced from a set of gravity values is dependent on a number of different factors: density contrasts between the body and the surrounding rock, the depth to the top and bottom of the body, the volume or horizontal extent of the body, and the influences from other gravitationally anomalous bodies. By placing limits on any one of these factor a more accurate picture of the subsurface can be produced. Determination of possible limits on these factors can come from a variety of sources: regional geology, density determination from typical rocks in the area or from laboratory measurements, depth to the top of the body from borehole data or from refraction or reflection seismic, and from previous gravity survey near or over the study area.

The granitic bodies of Nova Scotia have been studied for a number of years using a variety of methods. These studies place fairly good limits on the factors which influence a gravity model. These limitations can then be applied to the Liscomb Satellite Pluton. Douma (1978) determined that the average density contrast between Nova Scotia granites and their metasedimentary hosts is $-.09 \text{ g/cm}$. Detailed geological studies of the Main Liscomb Complex allows for the modelling of this large body located to the south of the Satellite Pluton. Brogan (1988) carried out a detailed gravity study over the Satellite Pluton in order to accurately define its boundaries. This study added to the body of knowledge by determining the

depth to the top of the Pluton and by placing new constraints on the depth extent of the Liscomb bodies and finally by examining the hypothesis of a possible contact between the Main Liscomb Complex and the Satellite Pluton.

Refraction seismic determined that the depth of the till layer over the Pluton was on the order of 10 meters. The affect of a less dense layer over the granite means that Brogan's Bouguer gravity values were in error ie. Brogan assumed that the entire rock column was of granite. However Table #3 show that the error generated from Brogan's assumption does not alter the gravity values by a large amount $\sim .2 - .3$ mgals. Therefore any models of the Pluton should have a relatively flat and unvarying top surface.

Brogan's model (1988) of the Satellite Pluton uses fairly high density contrasts, $-.17$ g/cm and $-.14$ g/cm for the Main Liscomb Complex and the Satellite Pluton respectively. The remodeling of the Pluton with constraints from the refraction seismics produced a model with more realistic density contrasts, $-.10$ g/cm and $-.08$ g/cm.

A major source of discrepancy between the calculated and the observed gravity data comes from the positioning of the northern contact of the Main Liscomb Complex. The gravitational modeling suggests that the blocks are located to far to the north, however the location of the blocks were determined by the geology i.e. the location of the granite outcrops (Giles and Chatterjee, 1987). A factor which could cause this discrepancy is the density contrasts. Since the calculated and observed

gravity values are in good agreement for most of the study area, the density might only be different in the northern section of the Main Liscomb Complex. A lower density contrast would better fit the data in this area.

CONCLUSIONS:

A refraction survey over the Pluton determined that the subsurface can be approximated by a three layer model. Layer 1 has an average velocity of 1725 m/sec and an average thickness of 9 meters. This layer represents the till layer. Layer 2 has an average velocity of 3500 m/sec and an average thickness of 14 meters. Thus representing the weathered granitic layer. The intensity of the weathering is due to the extremely porous nature of the tills of Nova Scotia. This second layer shows a large variation of velocities - 2800 m/sec to 4800 m/sec which is a result of the variation of weathering. The third layer which is basement has an average velocity of 5000 m/sec.

The large error involved in the determination of velocities of the layers means that refraction seismics can be used only to map the subsurface, it can not be used to differentiate between the granite and the metasediments. However, the refraction survey placed constraints on the depth to the top of the pluton. Which allowed for the more accurate modeling of the gravity data.

The new model was constructed from 15 blocks - #1-#5 bounding the Main Liscomb Complex, and #6-#15 representing the Satellite Pluton. The model shows a pluton with an elliptical

body having a north - south width of 3 km and an east - west length of 7 km. The body extends to a depth of 10 km. and shows no contact to the Main Liscomb Complex above a depth of 1.0 km. The top of the Pluton is at two depths - blocks to the south are shown to outcrop, while those to the north and the west are at a depth of 40 meters.

REFERENCES:

- Brogan, M., Gravity Modeling of the Liscomb Satellite Pluton. Honours Thesis, 1988.
- Bujak, J. P. and Donohoe, H.V., Geological Highway map of Nova Scotia; Atlantic Geoscience Society, Special Publication Number 1, 1980.
- Douma, M. Gravitational interpretation and Modeling of the South Mountain Batholith; BSc. Honours Thesis, Dalhousie University, 1978.
- Dobrin, M.B. and Savit, C.H., Introduction to Geophysical Prospecting, Fourth Edition, McGraw-Hill Book Company, New York, 867p., 1988.
- Giles, P.S. and Chatterjee, A.K., Peraluminous Granites of the Liscomb Complex. Nova Scotia Department of Mines and Energy Report: 87 - 1, pg 95 - 98, 1987.
- Grant, F.S., and West, G.F., Interpretation Theory in Applied Geophysics, New York, McGraw-Hill, 1965.
- Keppie, J.D., Geological Map of Nova Scotia. Nova Scotia Department of Mines and Energy, 1979.
- Mota, L. Determination of Dips and Depth of Geological Layer By Seismic Refraction Method, Geophysics, vol. 19, p. 242-254, 1954.
- Nagy, D., The gravitational Attraction of a Right Rectangular Prism; Geophysics, vol. 31, p. 363 -371, 1966.

Sten, R.R, and Fowler, J.H., Minor and Trace Element variations
in Wisconsinian Tills, Eastern Shore Region, Nova Scotia,
Nova Scotia Department of Mines and Energy, paper 79-4, 1979.

APPENDIX A: SEISMIC RECORDS

LINE # 1. Rec # 3 bearing 096 -- NORMAL

LINE 1 Record 3

39.1-382 = 0019 m/sec

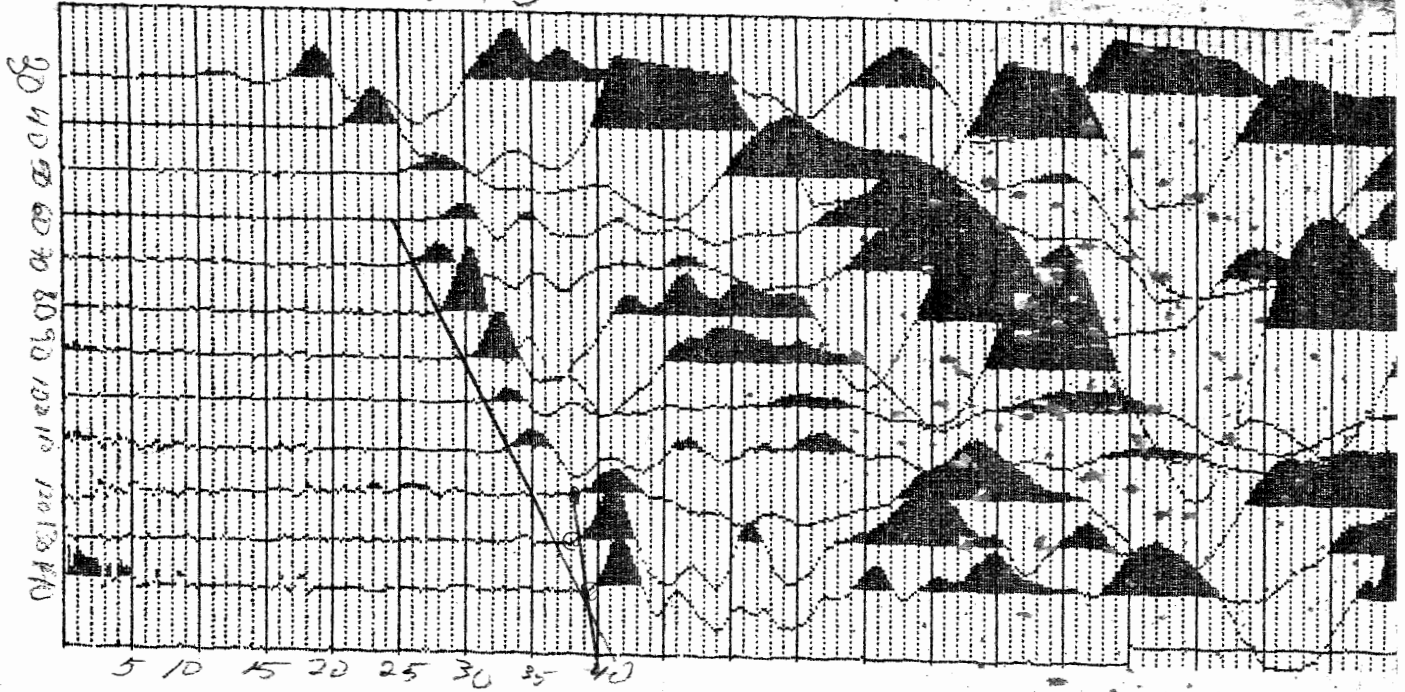

LINE # 1. Rec # 6 bearing 276 --REVERSED

Line 1 Rec 5 Rev

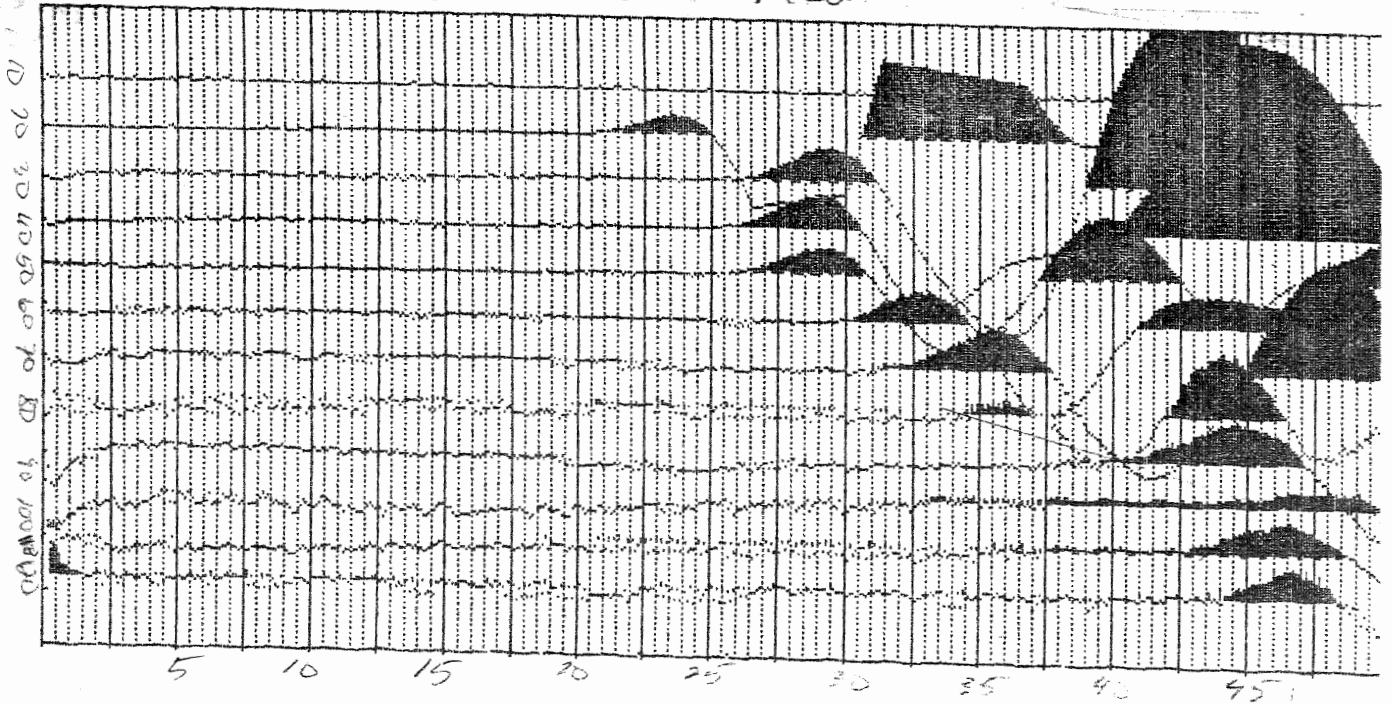

LINE # 2. Rec # 1 bearing 219 -- NORMAL

LINE 2 Record # 1

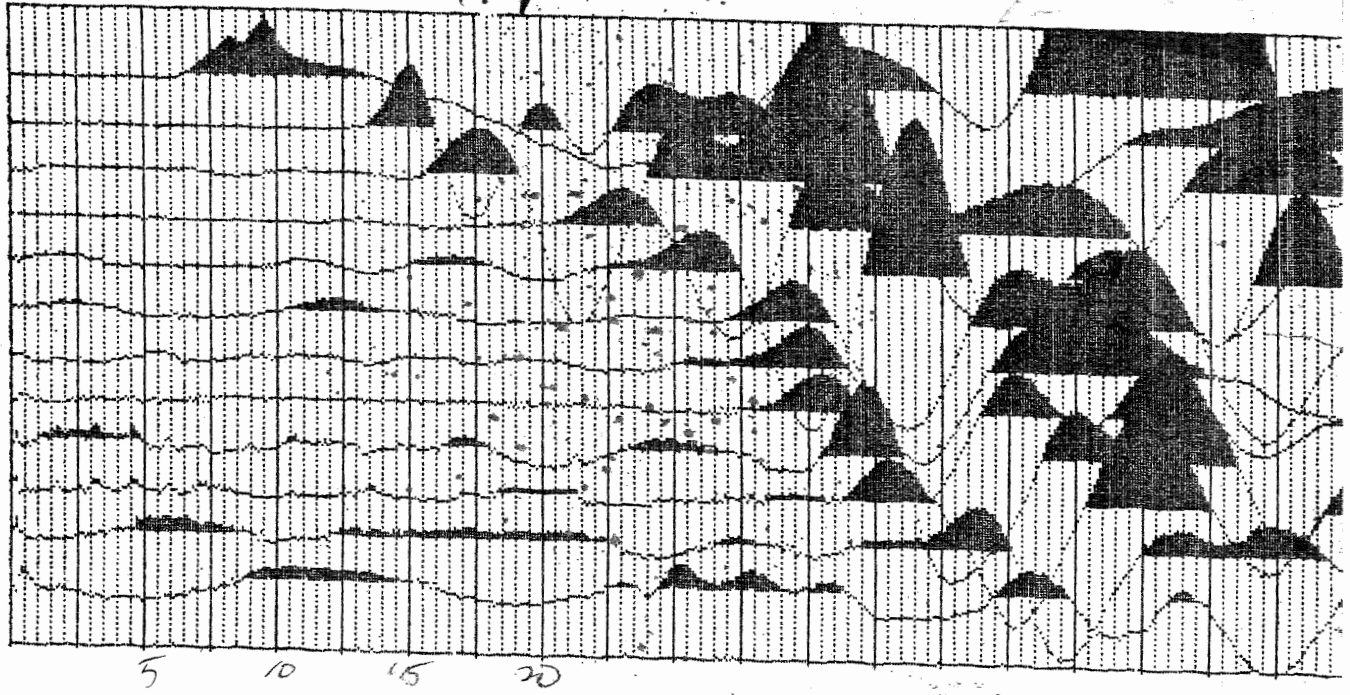

LINE # 2. Rec # 2 bearing 219 -- NORMAL

Line 2. Rec 2

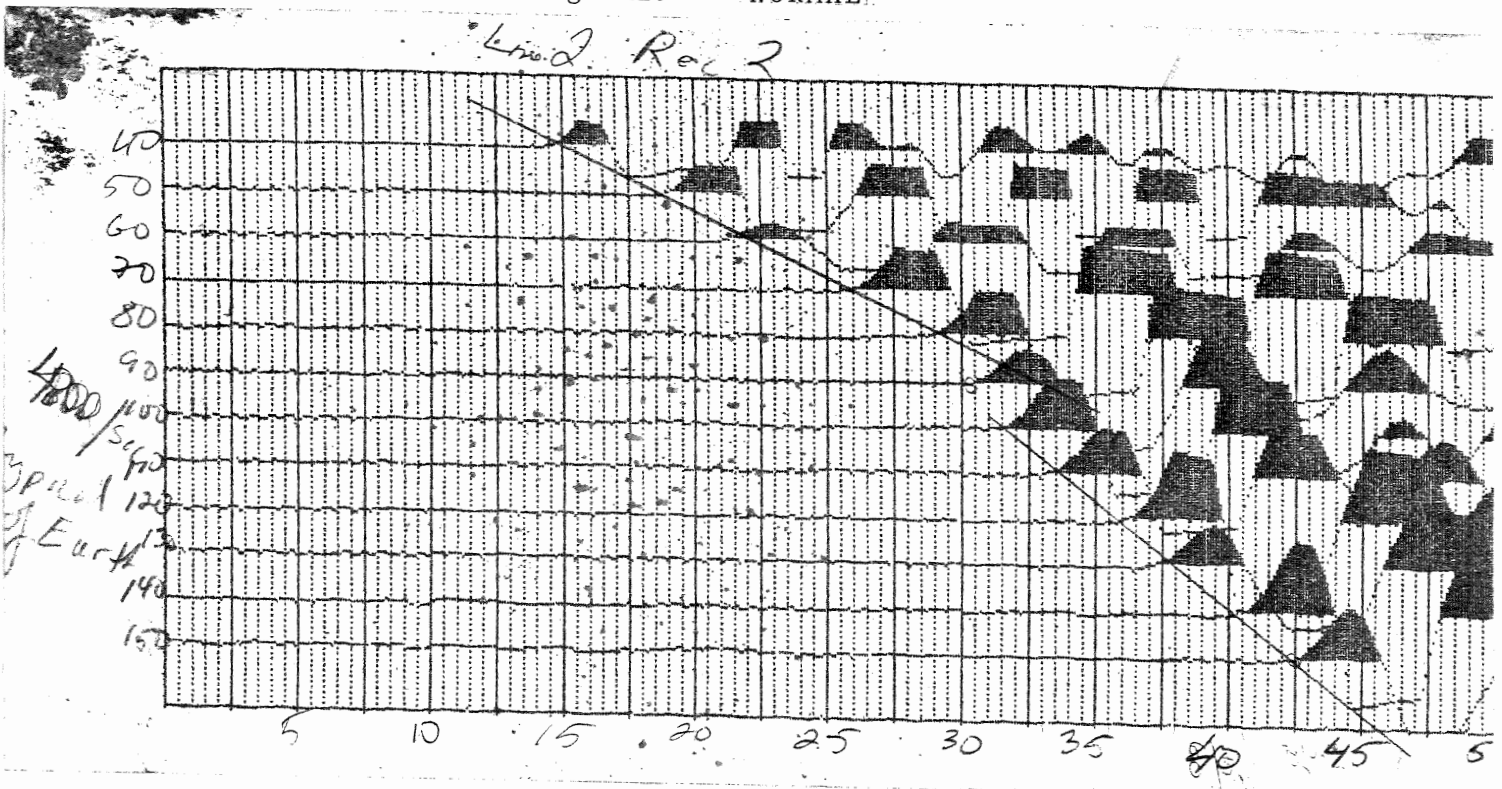

LINE # 2. Rec # 6 bearing 039 -- REVERSED

Line 2 Rec 6 Reverse

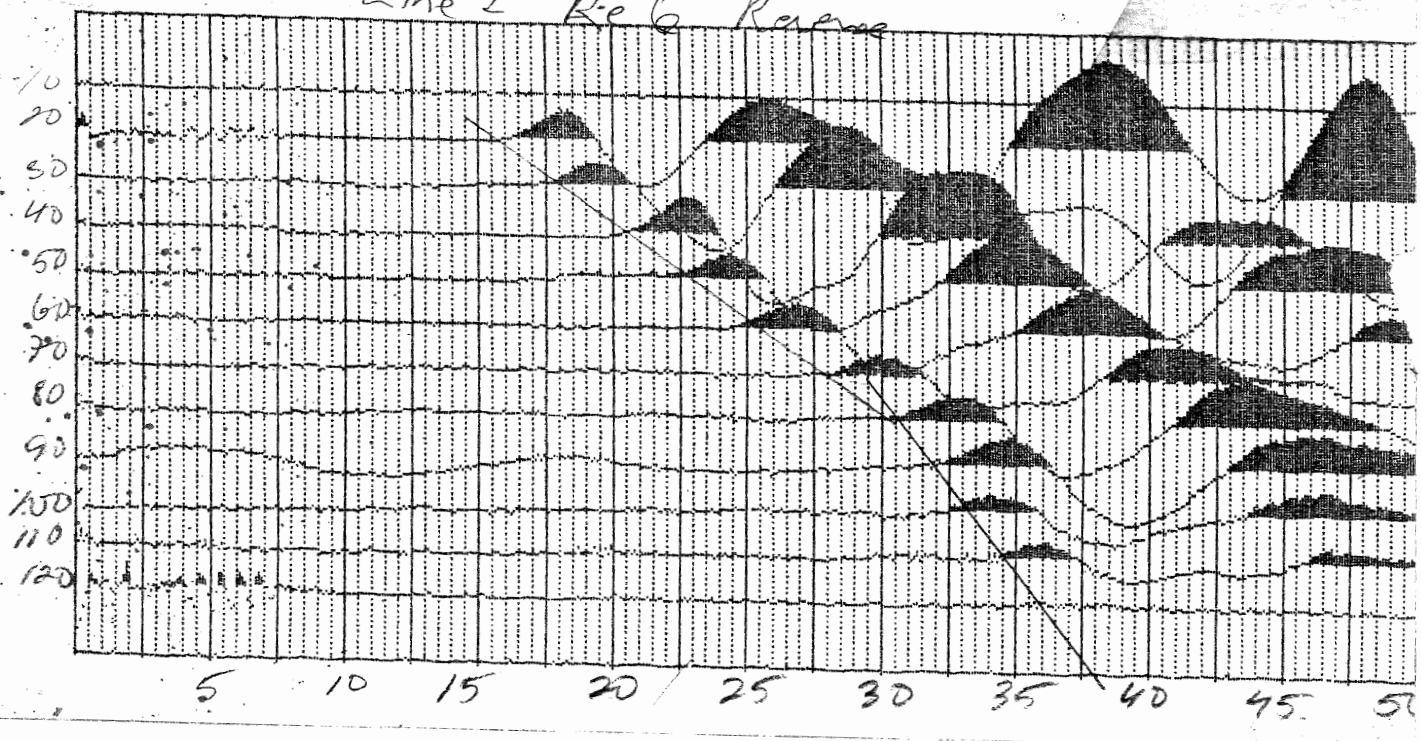

LINE # 3 Rec#1. bearing 358 -- NORMAL

Line 3 Rec 1

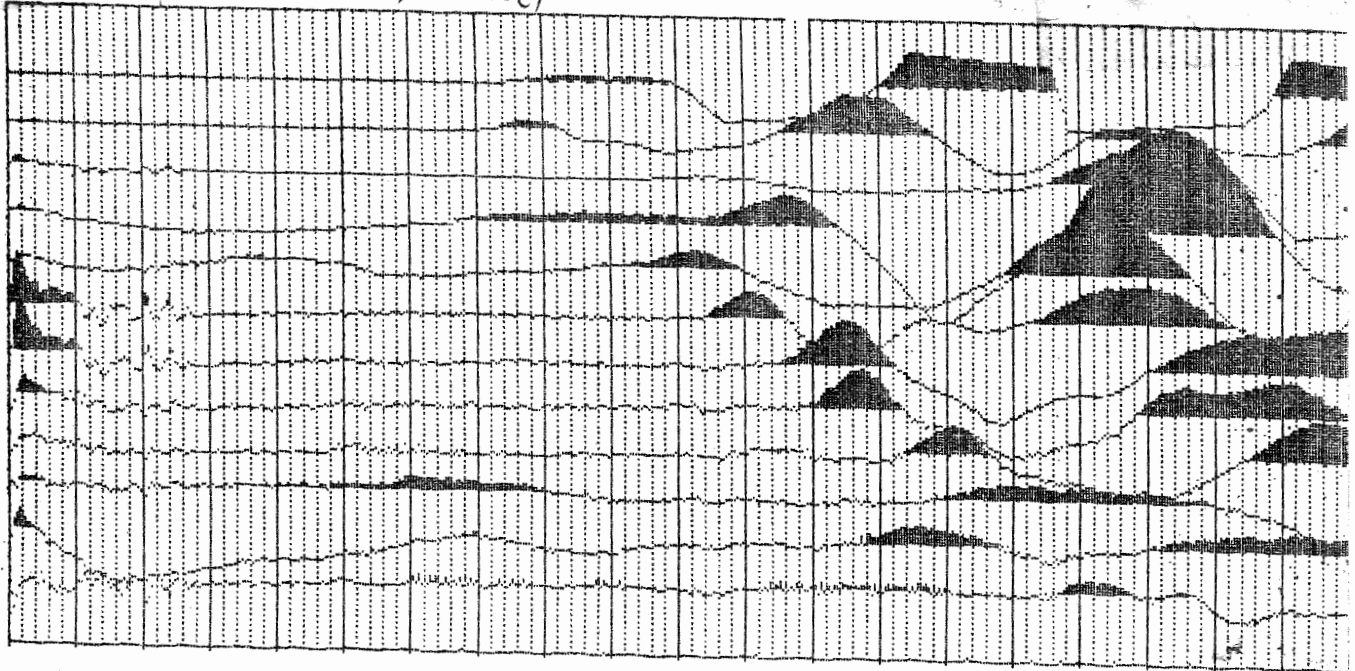

LINE # 3 Rec # 2. bearing 178 -- REVERSED

LINE 3 Rec 2

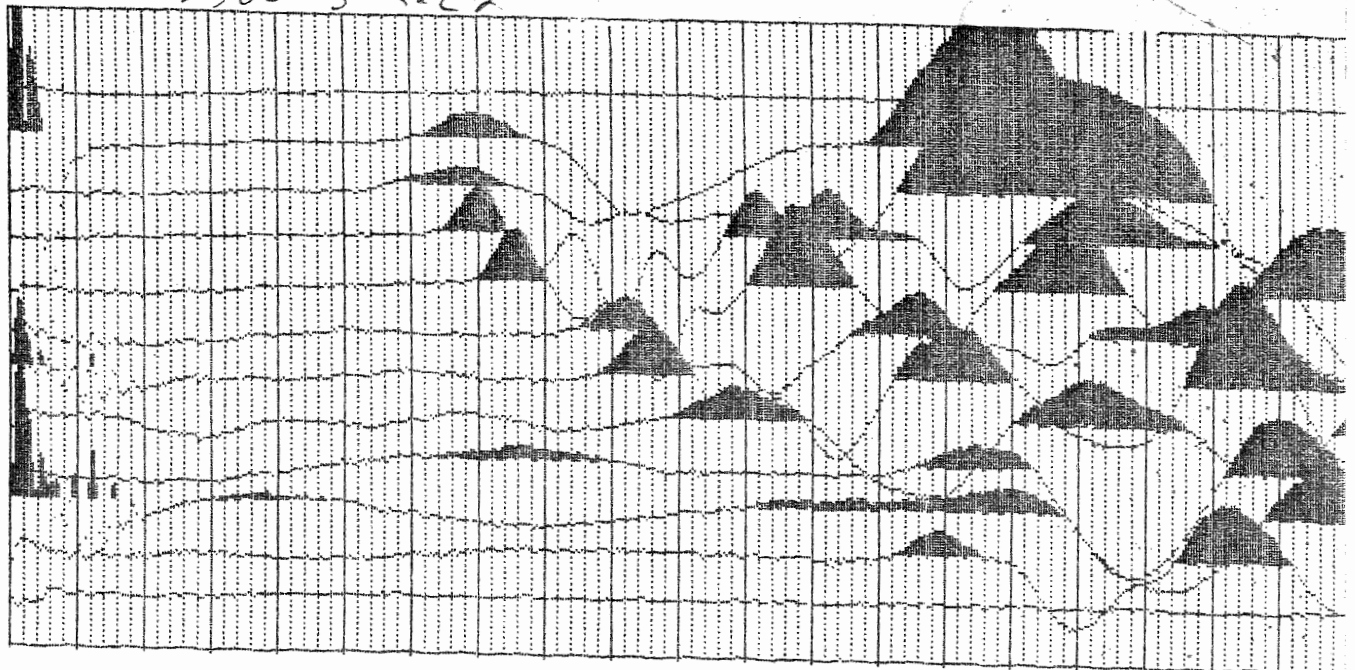

LINE # 4 Rec # 1. bearing 140 -- NORMAL

Line 4 Rec 1

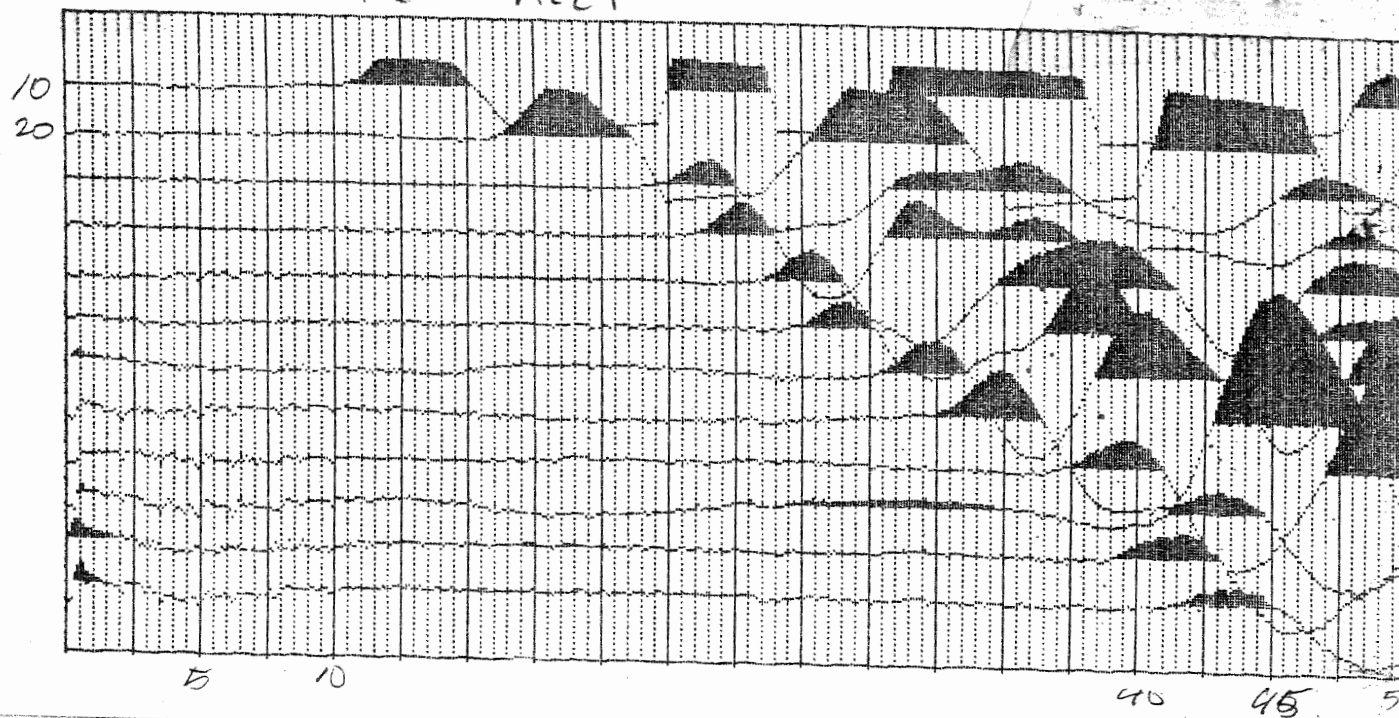

LINE # 4. Rec # 4. bearing 320 --REVERSED

Line 4 Rec 4 Reverse

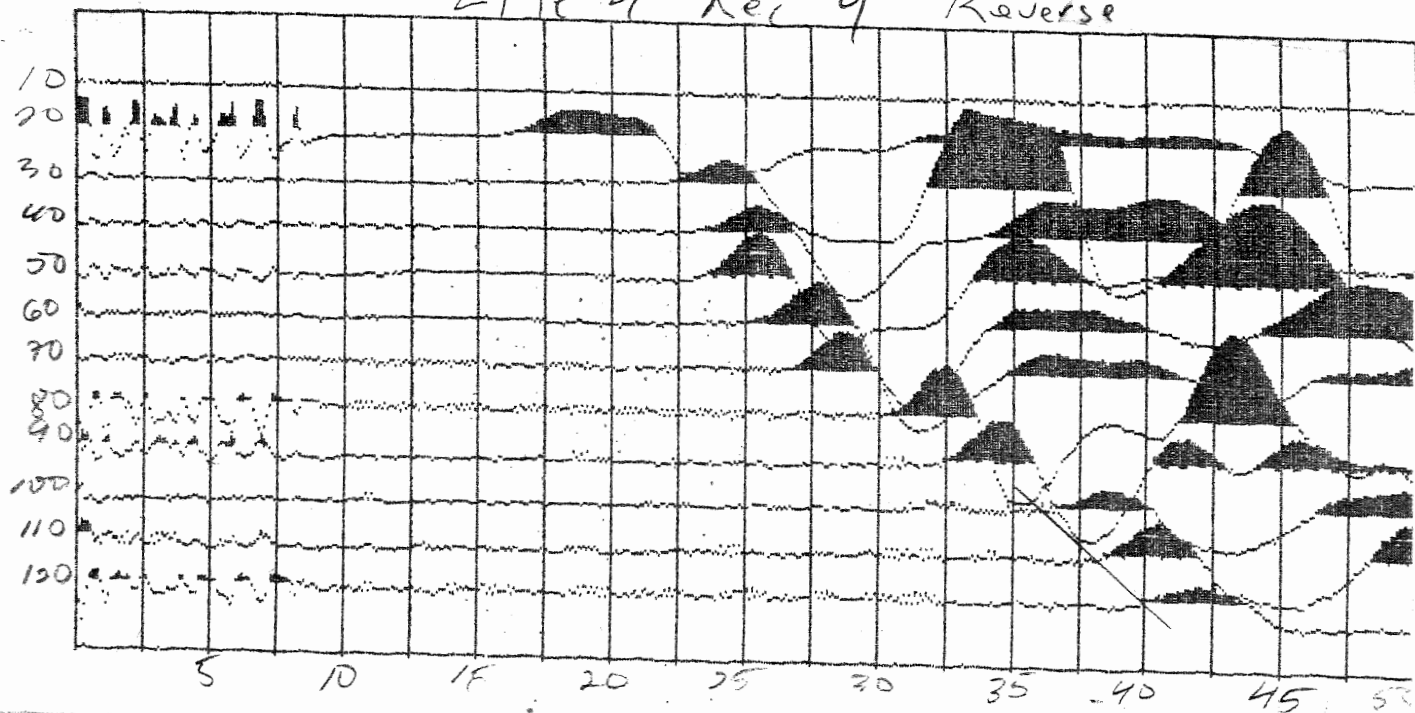

LINE # 5. Rec # 1. bearing 176 --NORMAL

Rec 5 #1 100 msec

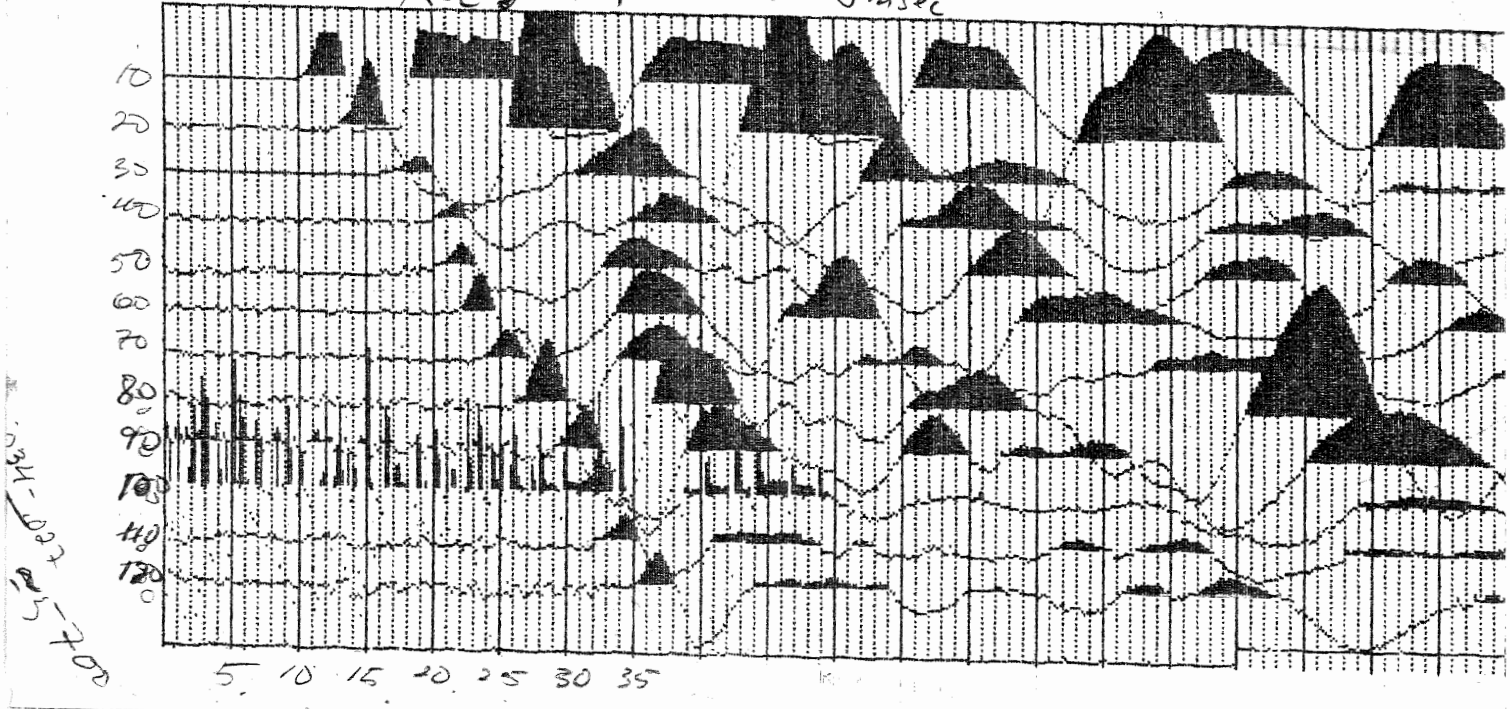

LINE # 5. Rec #2. bearing 356 -- REVERSE

LINE 5 Rec 2 Reverse 50 m/sec

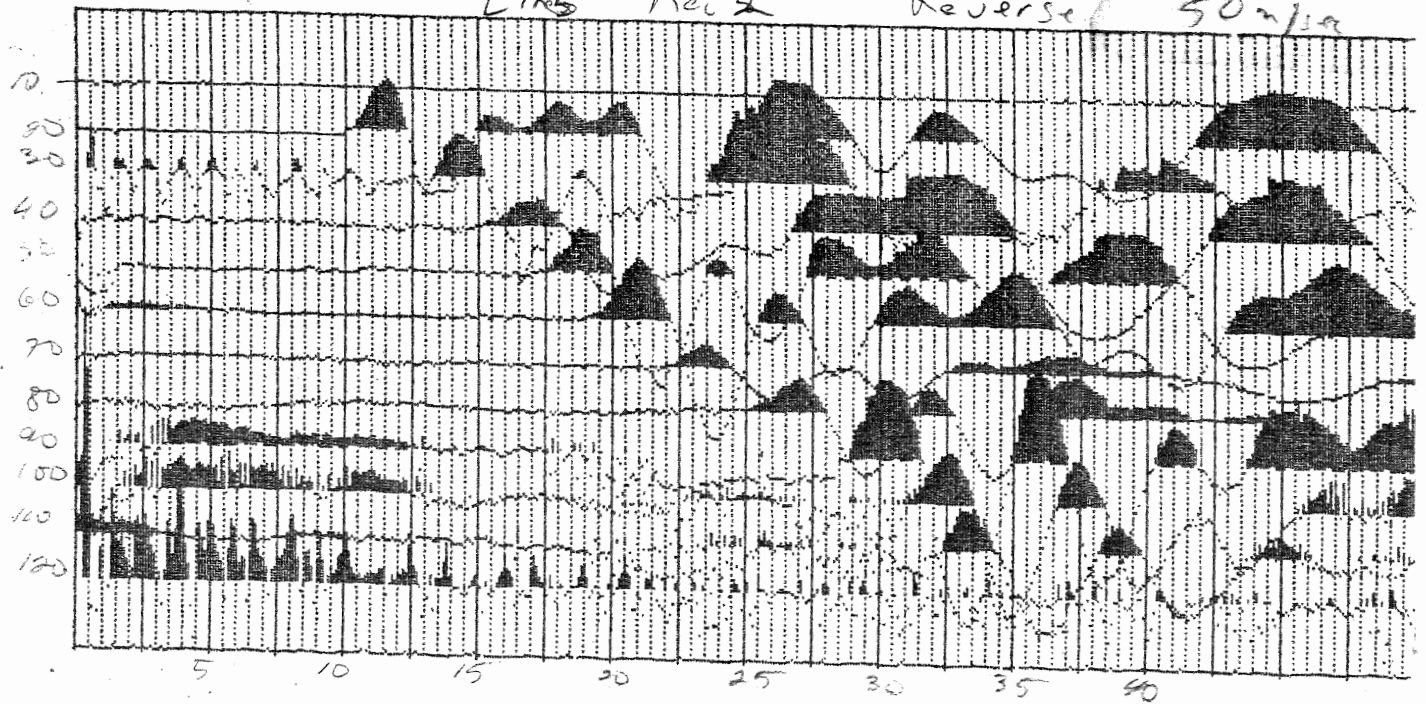

LINE # 6. Rec # 1. bearing 206 -- NORMAL

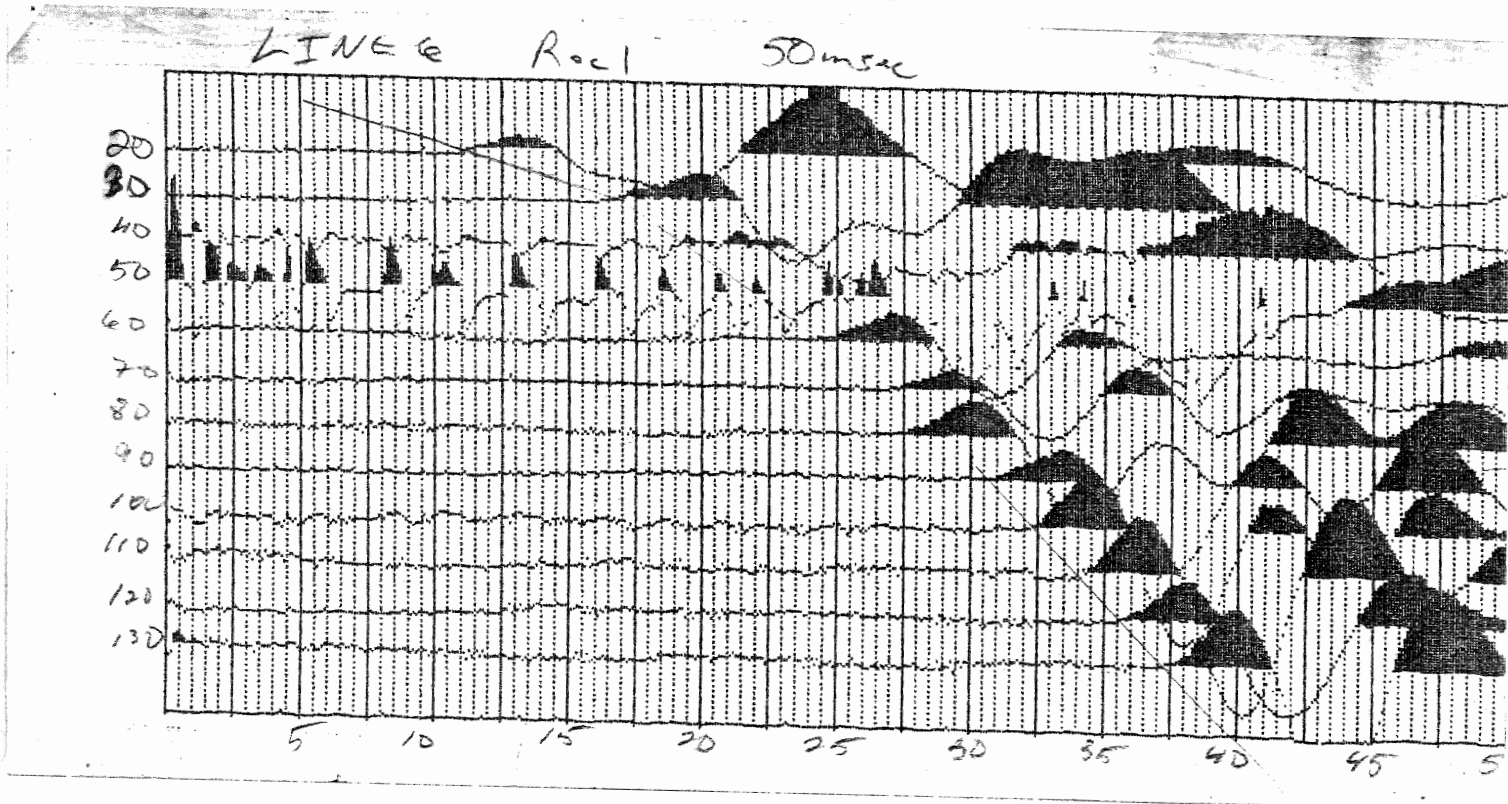

LINE # 6. Rec # 2. bearing 026 -- REVERSED

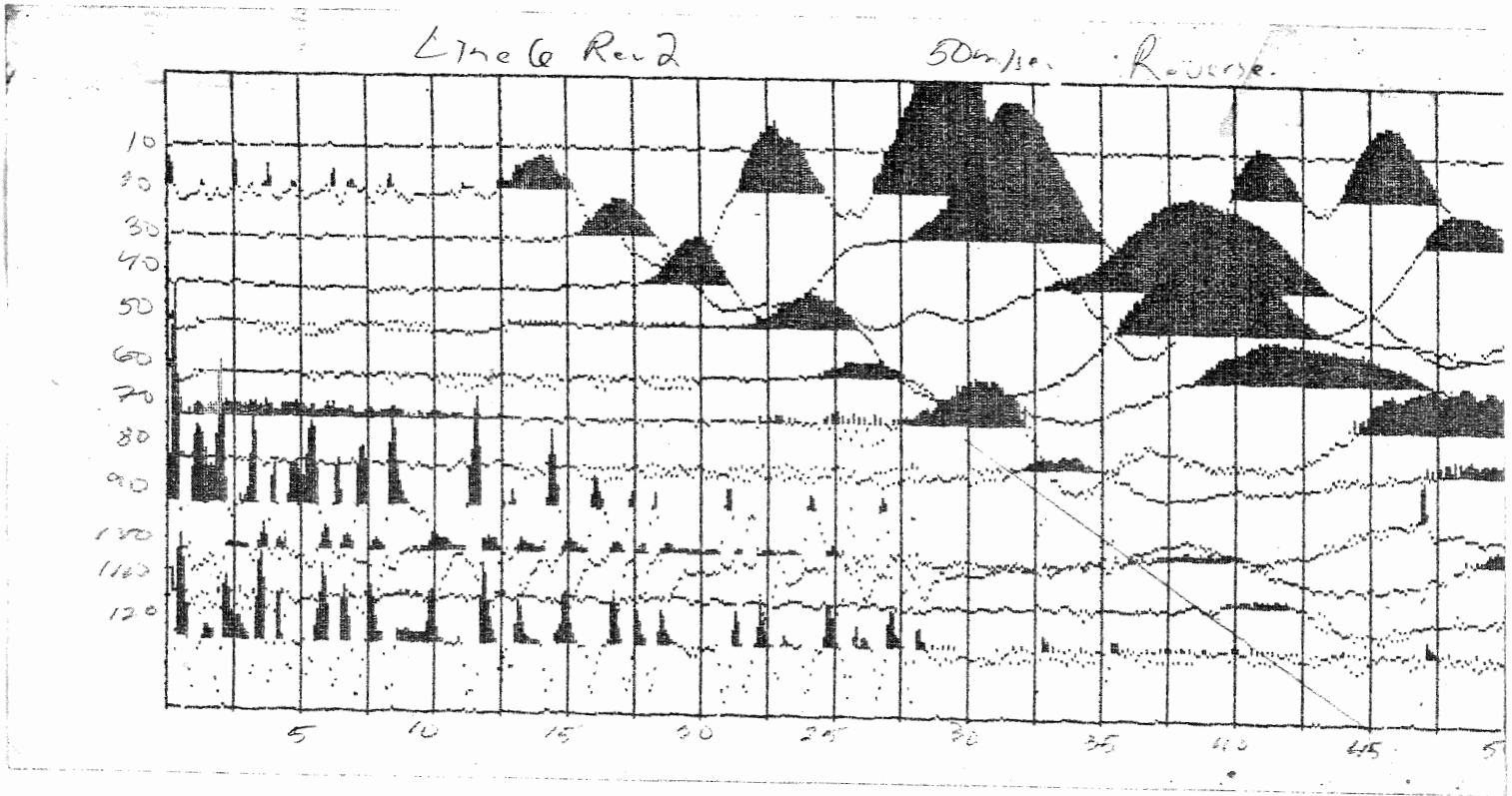

LINE # 7. Rec # 1. bearing 314 -- NORMAL

LINE 7 REC 1 50m/sec

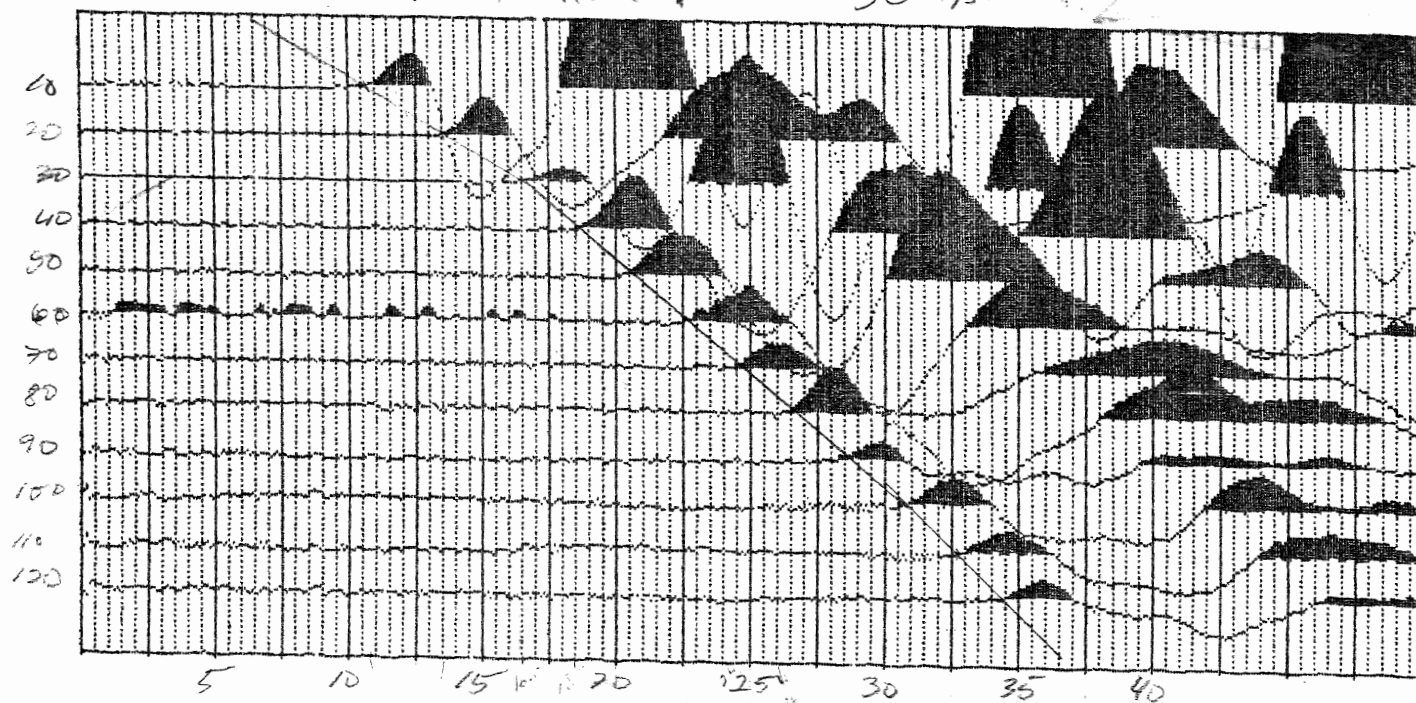

LINE # 7. Rec # 2. bearing 134 -- REVERSED

LINE 7 Rec 2 Rev. 50m/sec

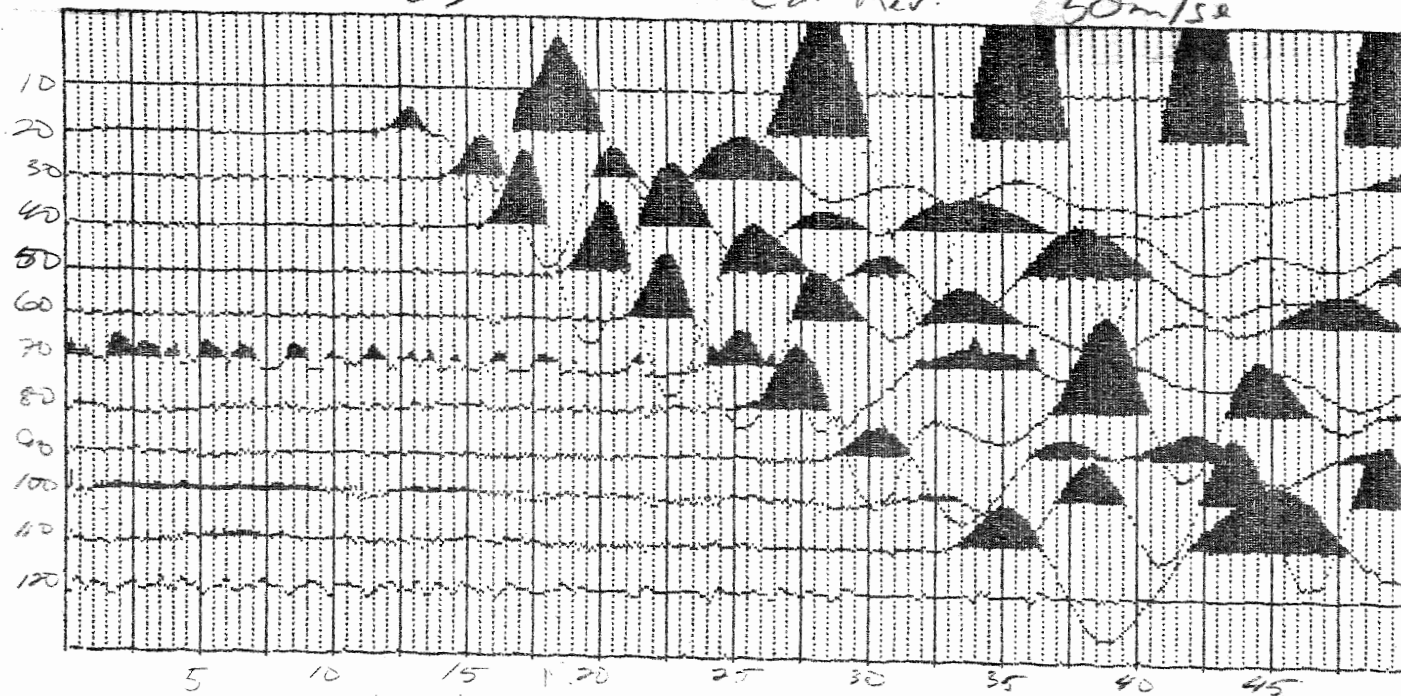

LINE # 7. Rec # 3. bearing 134 -- reversed

Reversed LINE 7 Rec 3 50m/sec

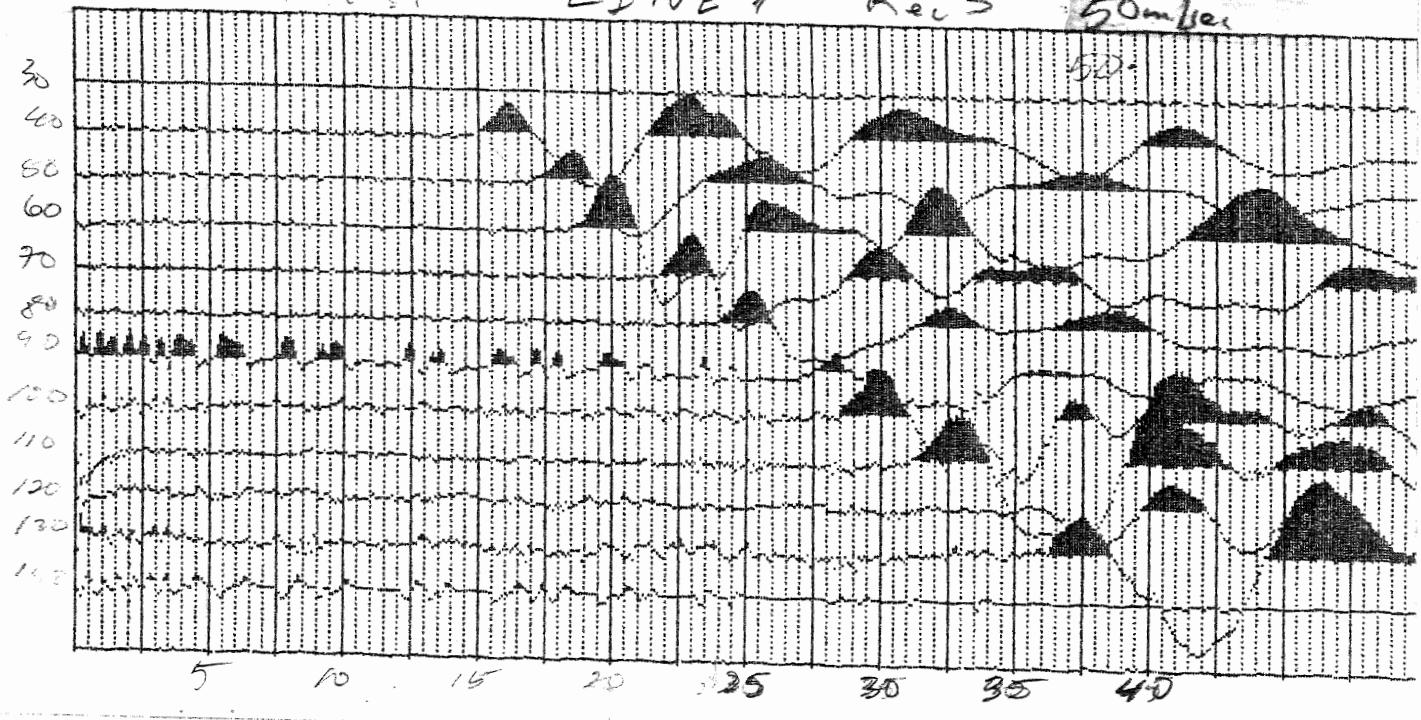

LINE # 8. Rec # 1, bearing 87 -- NORMAL

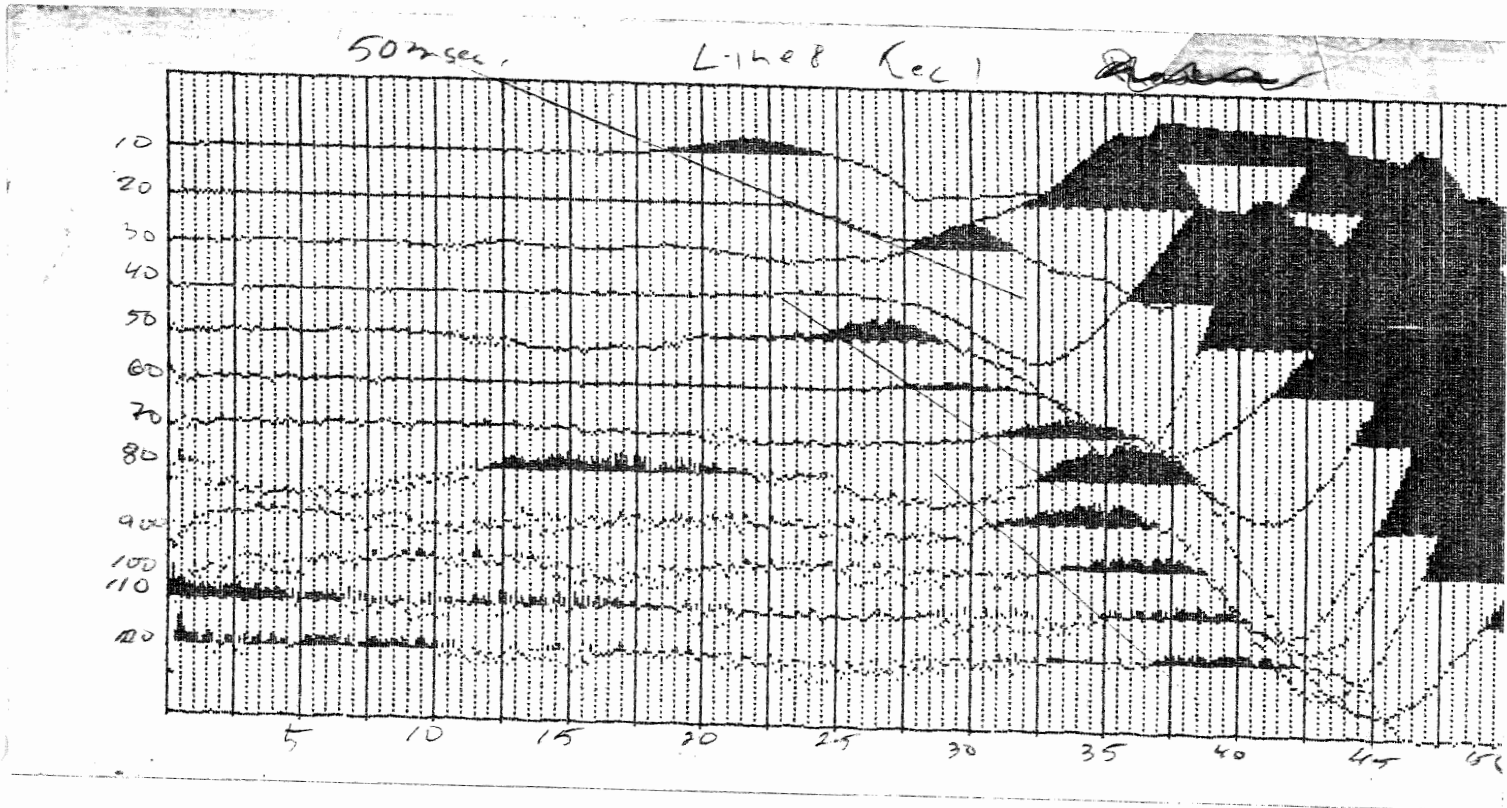

LINE # 8. Rec # 2. bearing 267 -- REVERSED

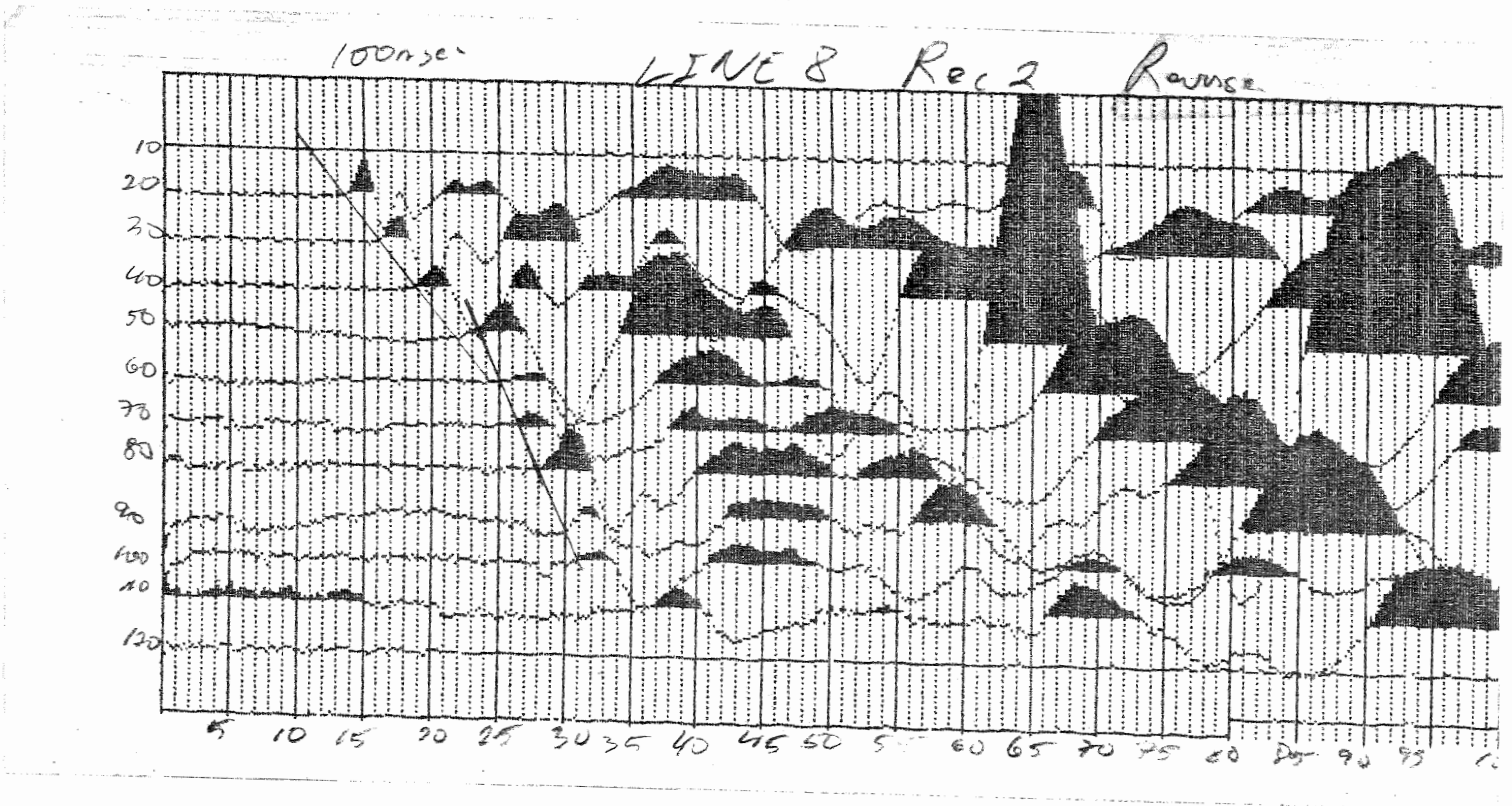

LINE # 9. Rec # 1. bearing 120 -- NORMAL

LINE 9 Rec 1

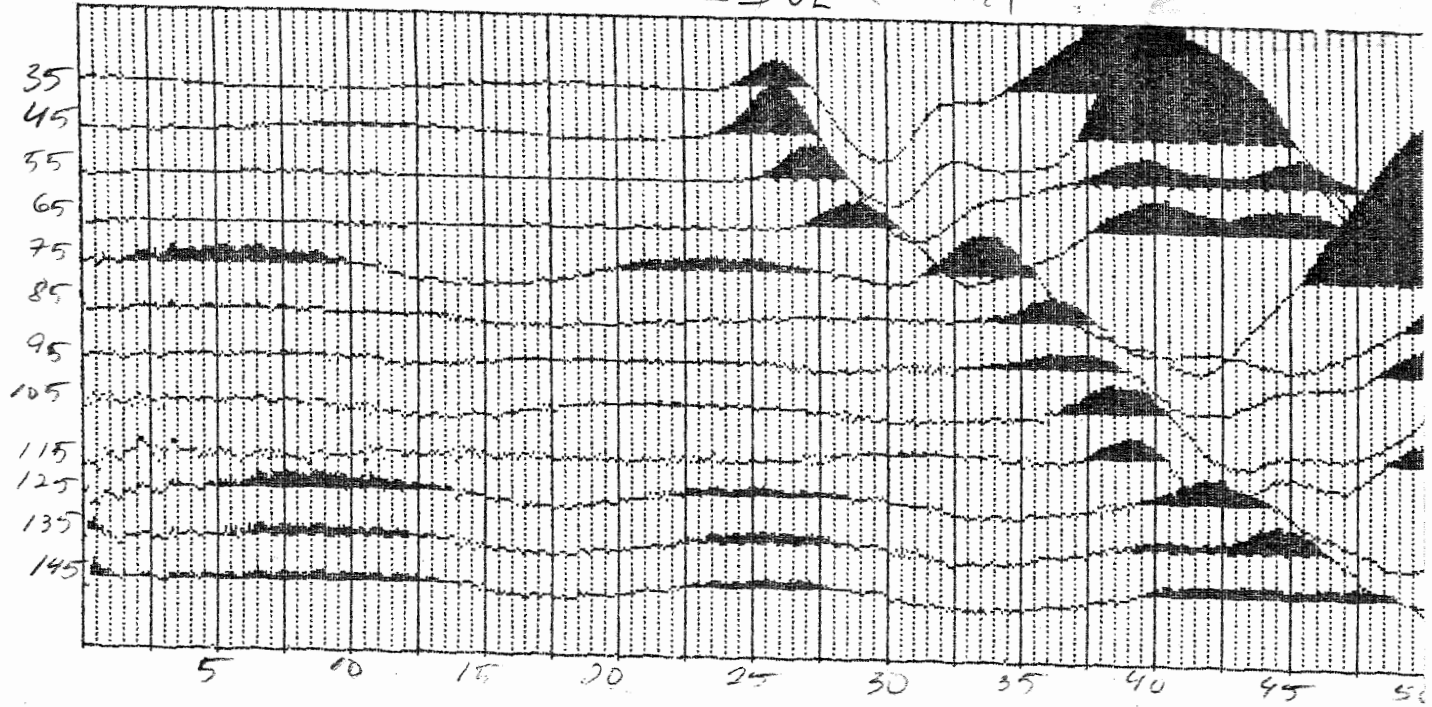

LINE # 9. Rec # 2. bearing 300 -- REVERSE

Line 9 Rec 2 Reverse

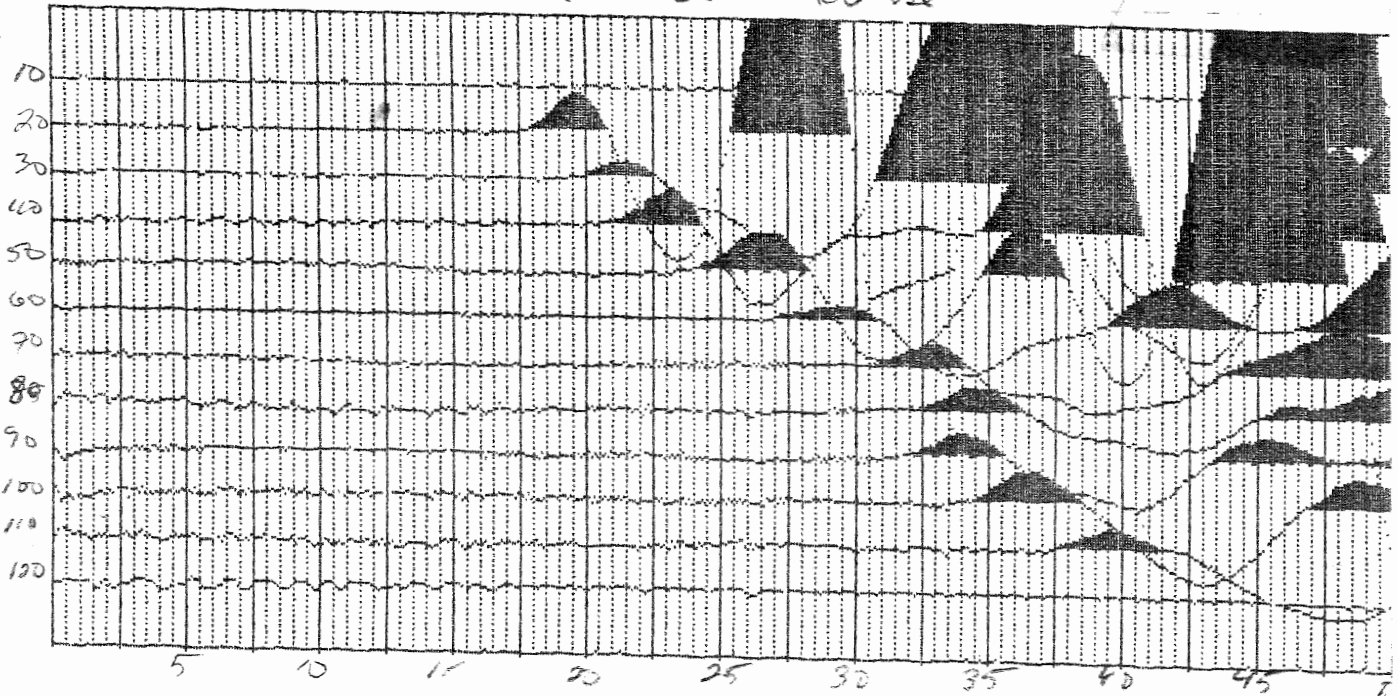

LINE # 10. Rec # 1. bearing -- 048 -- NORMAL

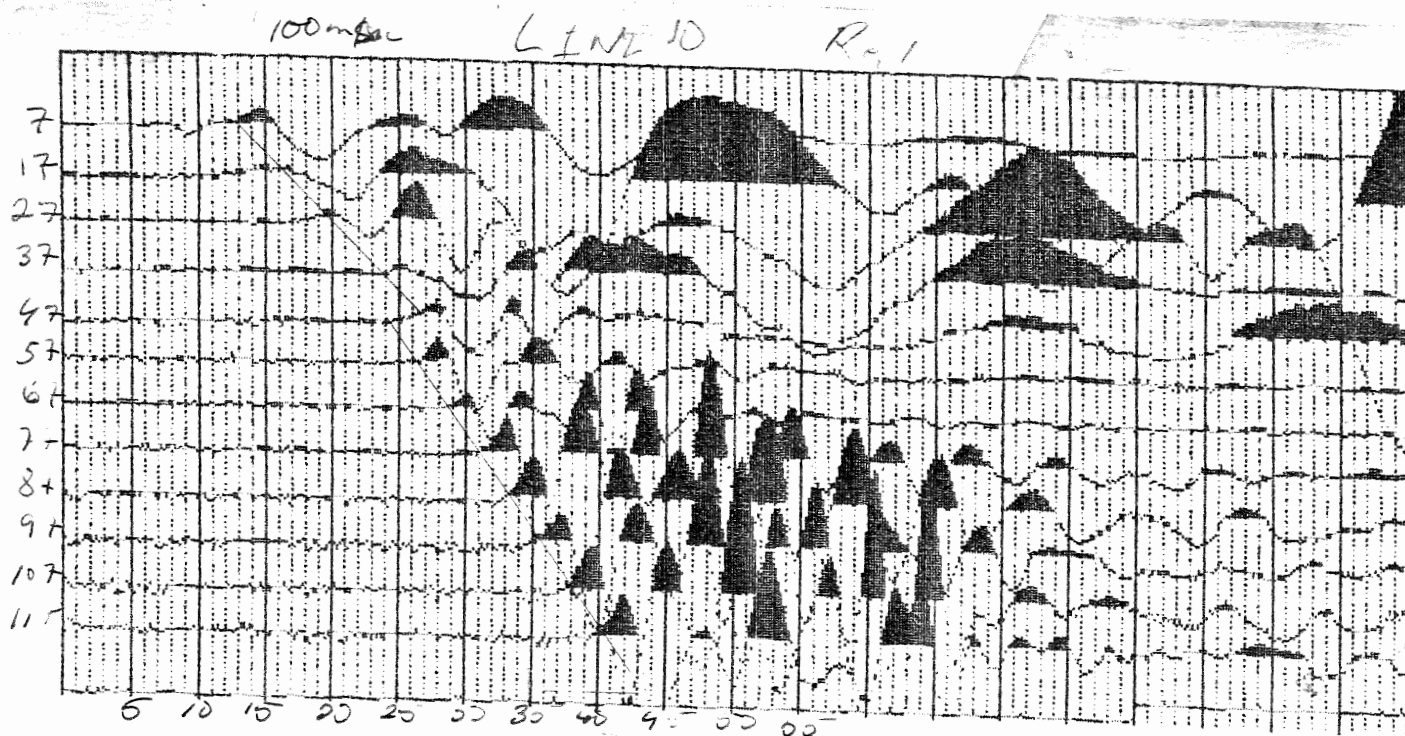

LINE # 10. Rec # 2. bearing 228 -- REVERSED

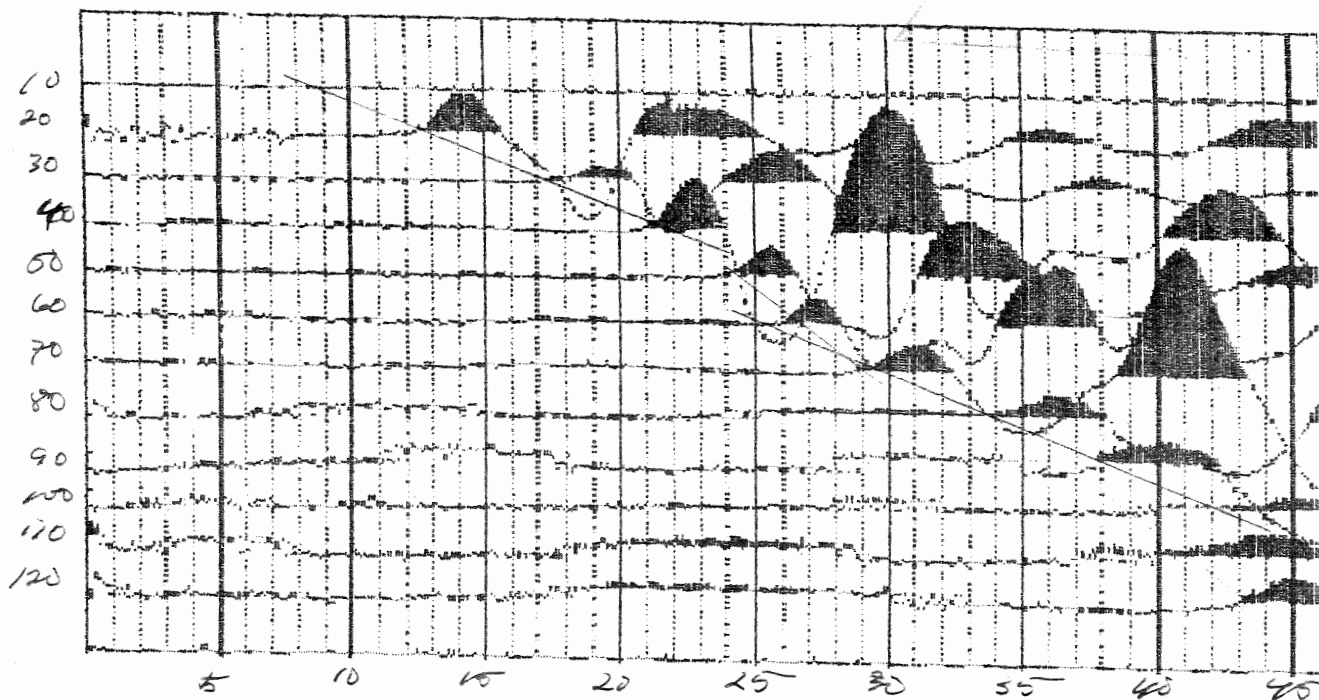

LINE # 11. rec # 1. bearing 265 -- NORMAL

LINE 11 Rec 1

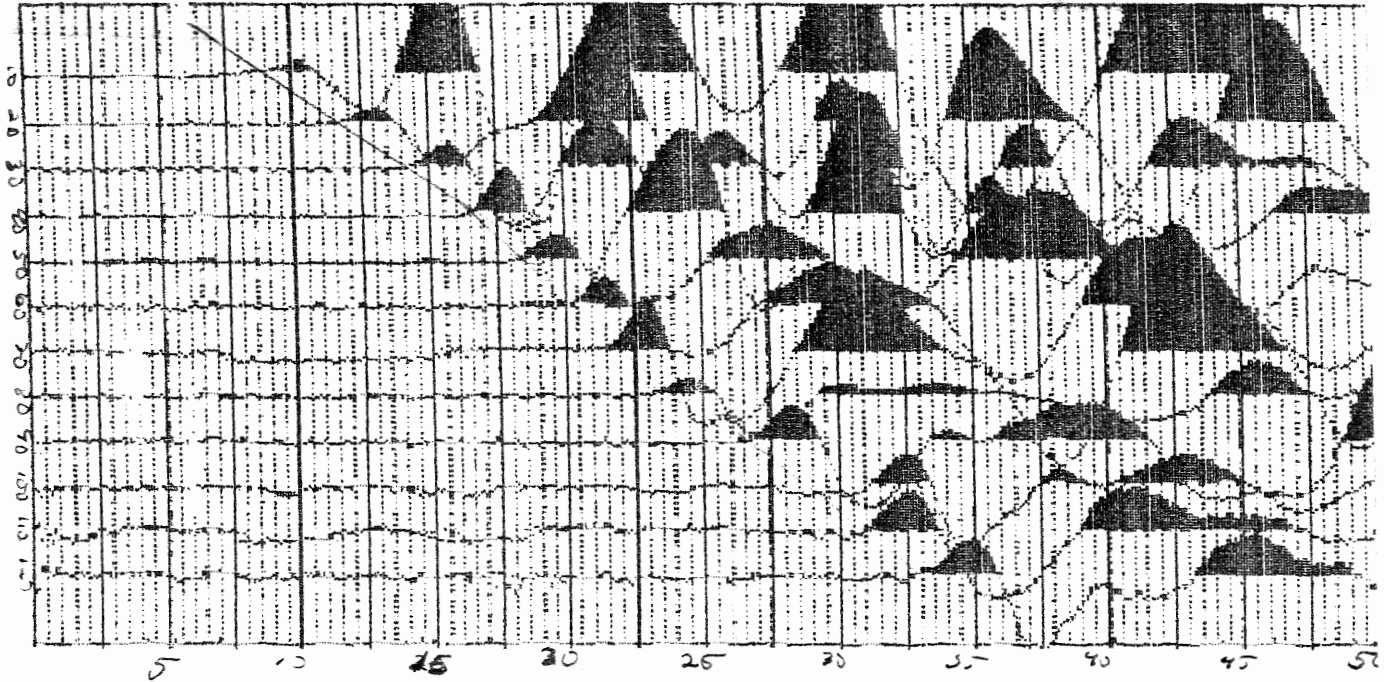

LINE # 11. Rec # 2. bearing 85 -- REVERSED

LINE 11 Rec 2

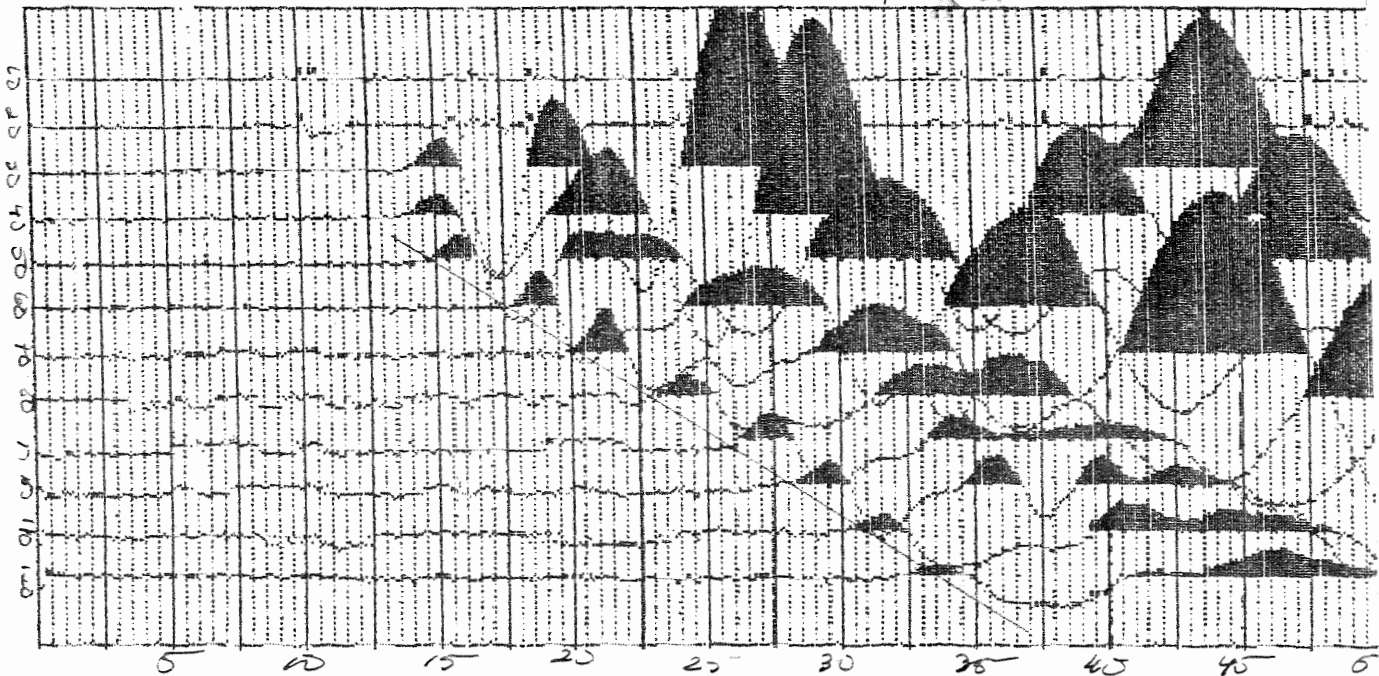

LINE # 12. Rec. 1, bearing 175 -- NORMAL

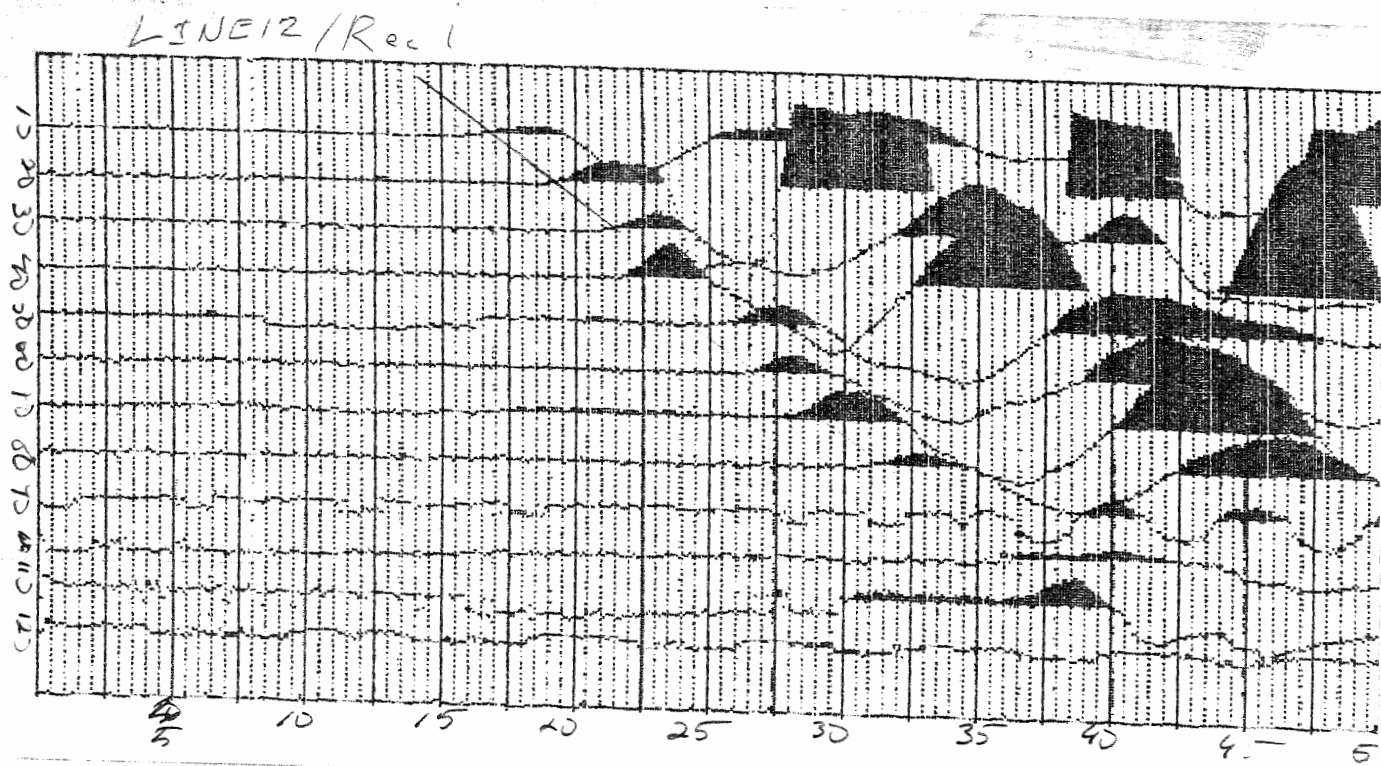

LINE # 12. Rec.2, bearing 355-- REVERSED

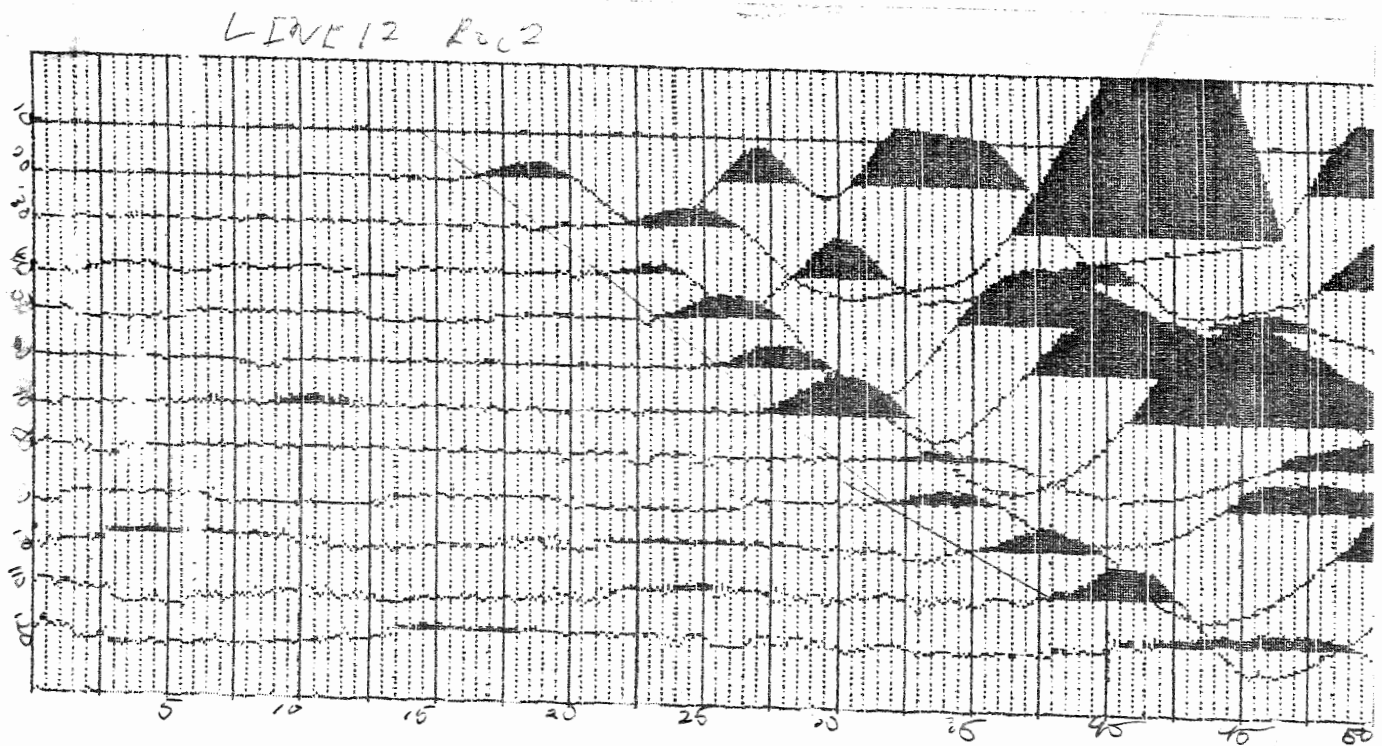

LINE # 13. Rec. # 1 bearing 167 -- NORMAL BUFFALO GUN SOURCE

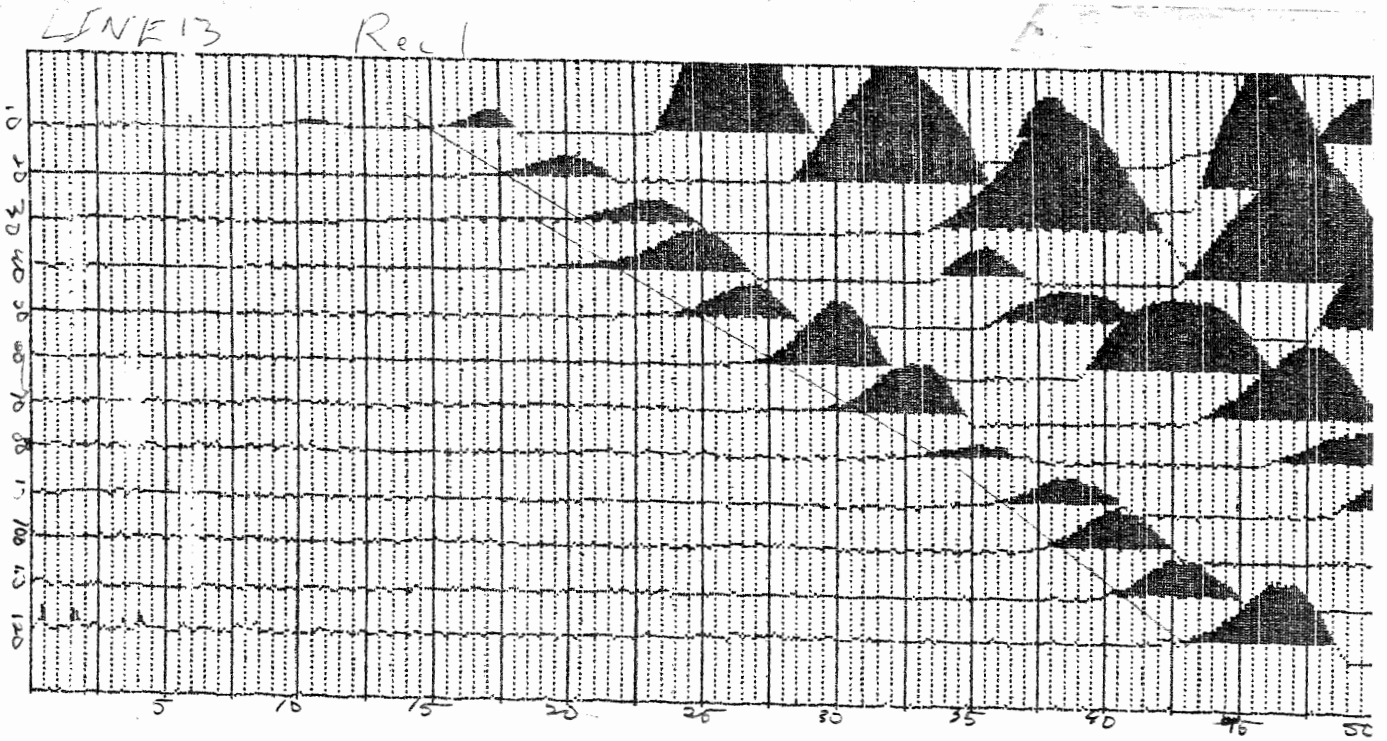

LINE # 13. Rec # 2 bearing 167 -- NORMAL HAMMER SOURCE

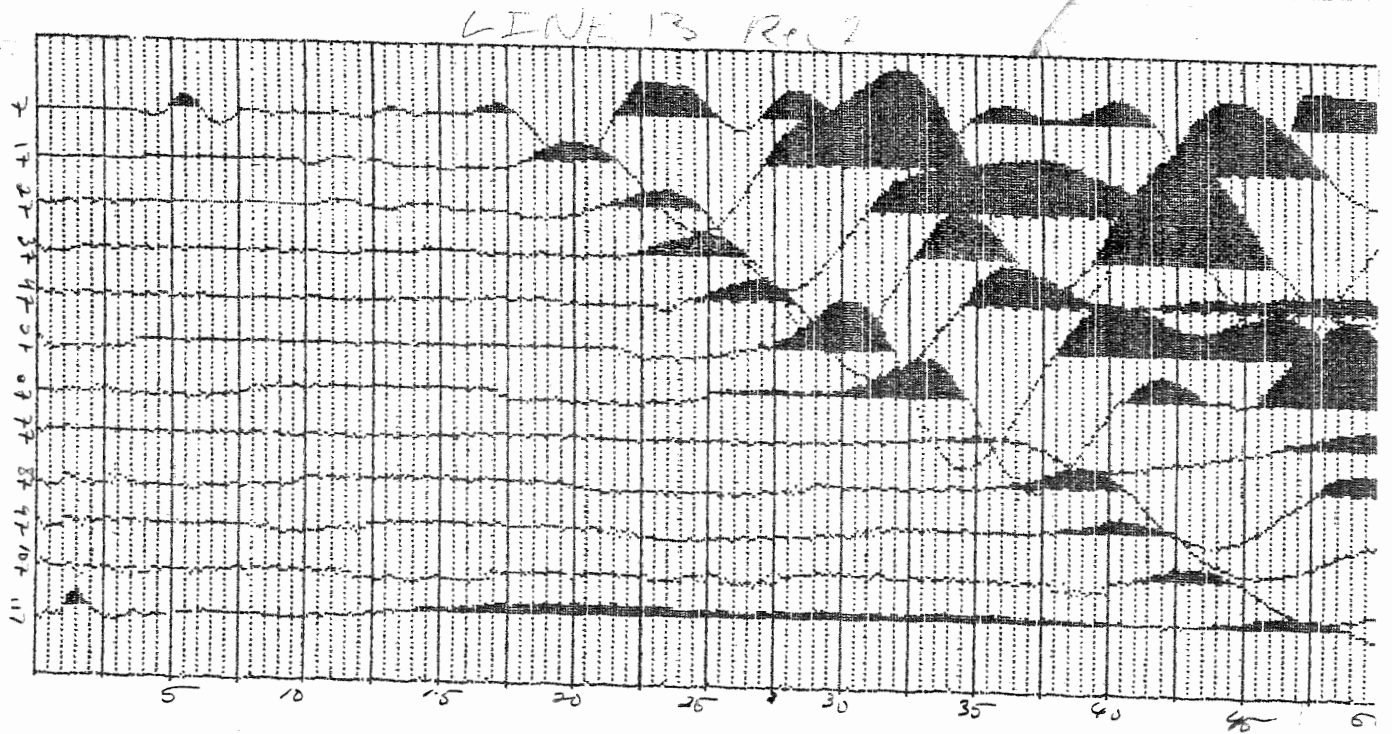

LINE # 13. Rec # 3 bearing 347 -- REVERSED

LINE 13 Rec 3

50 m/sec.

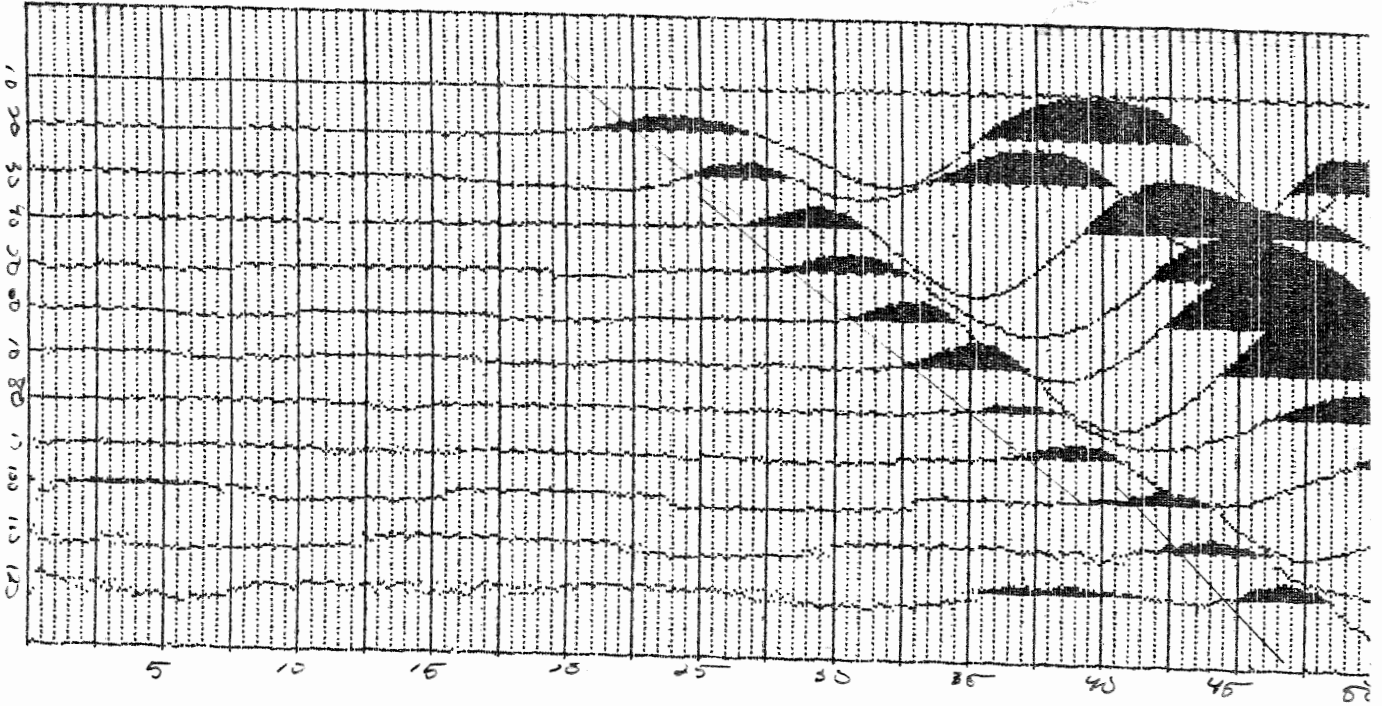

LINE # 14. Rec #1. 720 Meter Spread

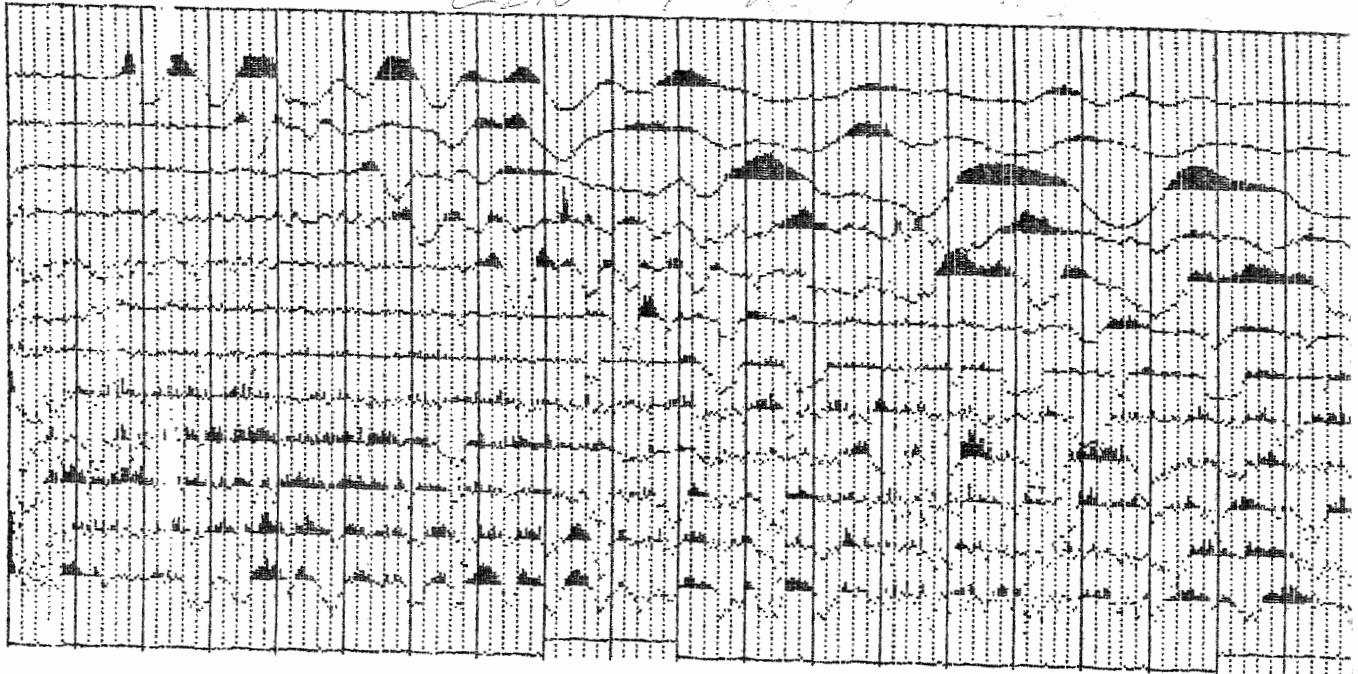

APPENDIX B:

Determination of velocities, dips and depths was accomplished using equations from Mota (1954). The times for the first arrivals were plotted versus distance for both normal and reversed profiles (Graph #1 - #13). The slopes of the lines, and the y - intercept for each graph was used to calculate the velocities, depths and dips for a 3 layer model i.e. two refractors (Figure #7 shows the relationship between the graphs and the geometry of the refracting layers.

Determination of velocities and dips:

From figure #7, we can see that:

$$\phi (\text{dip of top layer}) = \frac{\arcsin (V_o/V_b) - \arcsin (V_o/V_a)}{2}$$

where V_o = velocity of top layer.

V_a = updip velocity in the second layer.

V_b = downdip velocity in the second layer.

The critical angle can be determined by:

$$i_c = \frac{\arcsin (V_o/V_b) + \arcsin (V_o/V_a)}{2}$$

Thus the true velocity of the second layer (V_1) is:

$$V_1 = V_o / \sin i_c,$$

$$\phi (\text{dip of second layer}) = \frac{[\arcsin (V_1/V_o * \sin \alpha_{2,1}) - \arcsin (V_1/V_o * \sin \beta_{2,1})]}{2} + \phi_1$$

where $\alpha_{2,1} = \arcsin (V_o/V_{2b}) - \phi$

$\beta_{2,1} = \arcsin (V_o/V_{2a}) + \phi$

and V_{2b} = downdip velocity in the third layer.

V_{2a} = updip velocity in the third layer.

The critical angle for this second refractor is:

$$i_c = \frac{[\arcsin (V_1/V_o * \sin \alpha_{2,1}) + \arcsin (V_1/V_o * \sin \beta_{2,1})]}{2}$$

Thus the true velocity of the third layer (V_2) is:

$$V_2 = V_1 / \sin i_{c_2}$$

Determination of depths:

First thickness of the top layer was determined (Z):

$$z_1 = \frac{1 * T_{1b} * V_0 / \cos i_{c_1}}{2}$$

$$Z_1 = \frac{1 * T_{1a} * V_0 / \cos i_{c_1}}{2}$$

where z_1 = thickness of layer downdip.
 Z_1 = thickness of layer updip.
 T_{1b} = y - intercept time for downdip direction.
 T_{1a} = y - intercept time for updip direction.

Depths to the top of the second layer can be determined by multiplying z_1 and Z_1 with $1/\cos i_{c_2}$.

Thickness of the second layer can be found using:

$$Z_{2,2} = \frac{V_1 * (T_{2a} - \{Z_1 / V_0 * \cos(\alpha_{2,1} + \beta_{2,1}) + 1 / \cos \alpha_{2,1}\})}{2 \cos i_{c_2}}$$

$$z_{2,2} = \frac{V_1 * (T_{2b} - \{z_1 / V_0 * \cos(\alpha_{2,1} + \beta_{2,1}) + 1 / \cos \beta_{2,1}\})}{2 \cos i_{c_2}}$$

where $Z_{2,2}$ = thickness of second layer updip.
 $z_{2,2}$ = thickness of second layer downdip.
 T_{2a} = y - intercept time of second layer for updip direction.
 T_{2b} = y - intercept time of second layer for downdip direction.

Depths to the the top of the third layer can then be determined by:

$$H_2 = 1 / \cos \phi_2 * [Z_1 * \{ \cos(\alpha_{2,1} - \phi_2 + \phi_1) / \cos \alpha_{2,1} \} + Z_{2,2}]$$

$$h_2 = 1 / \cos \phi_2 * [z_1 * \{ \cos(\beta_{2,1} + \phi_2 - \phi_1) / \cos \beta_{2,1} \} + z_{2,2}]$$

LINE #1

63.

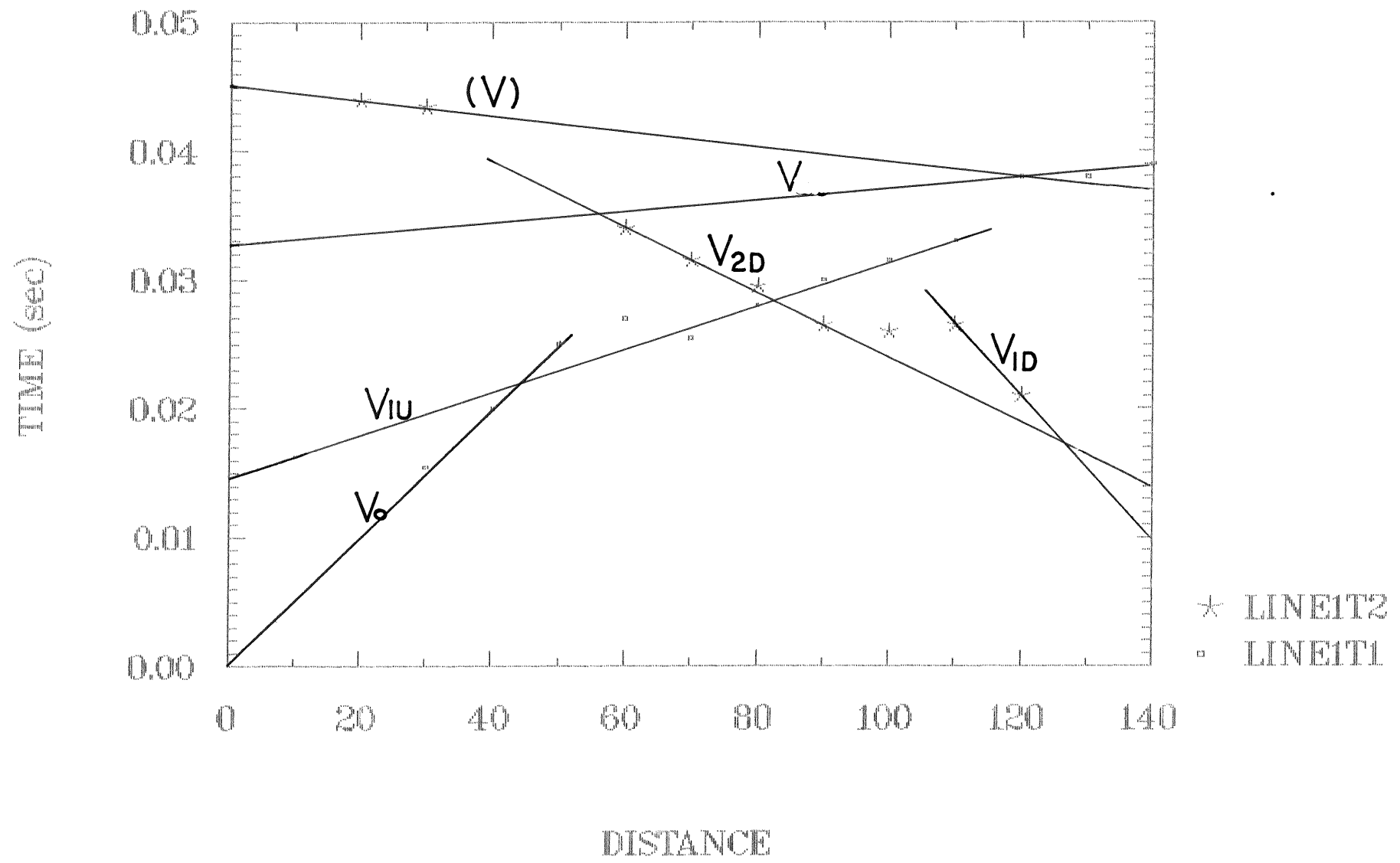

LINE #2

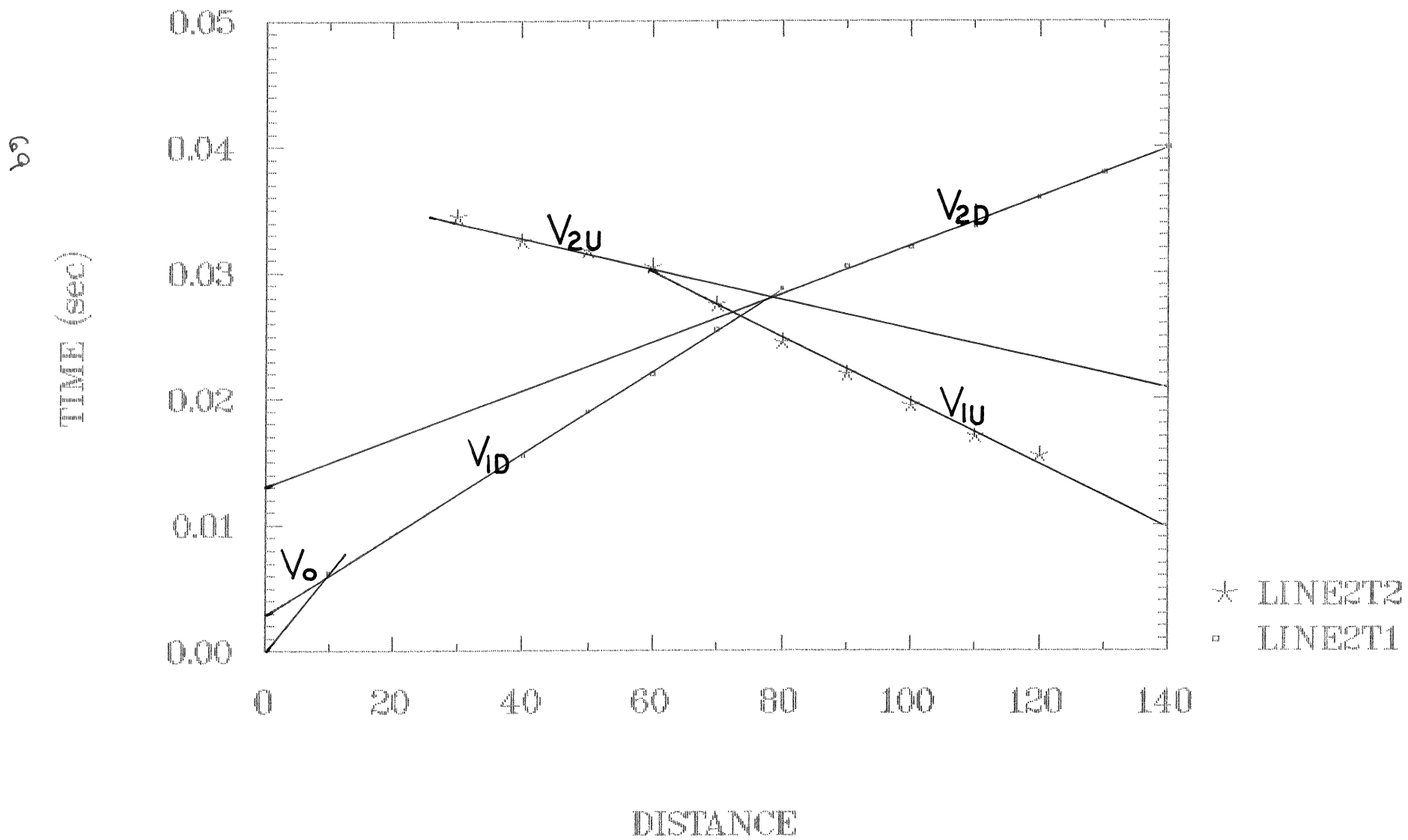

LINE #4

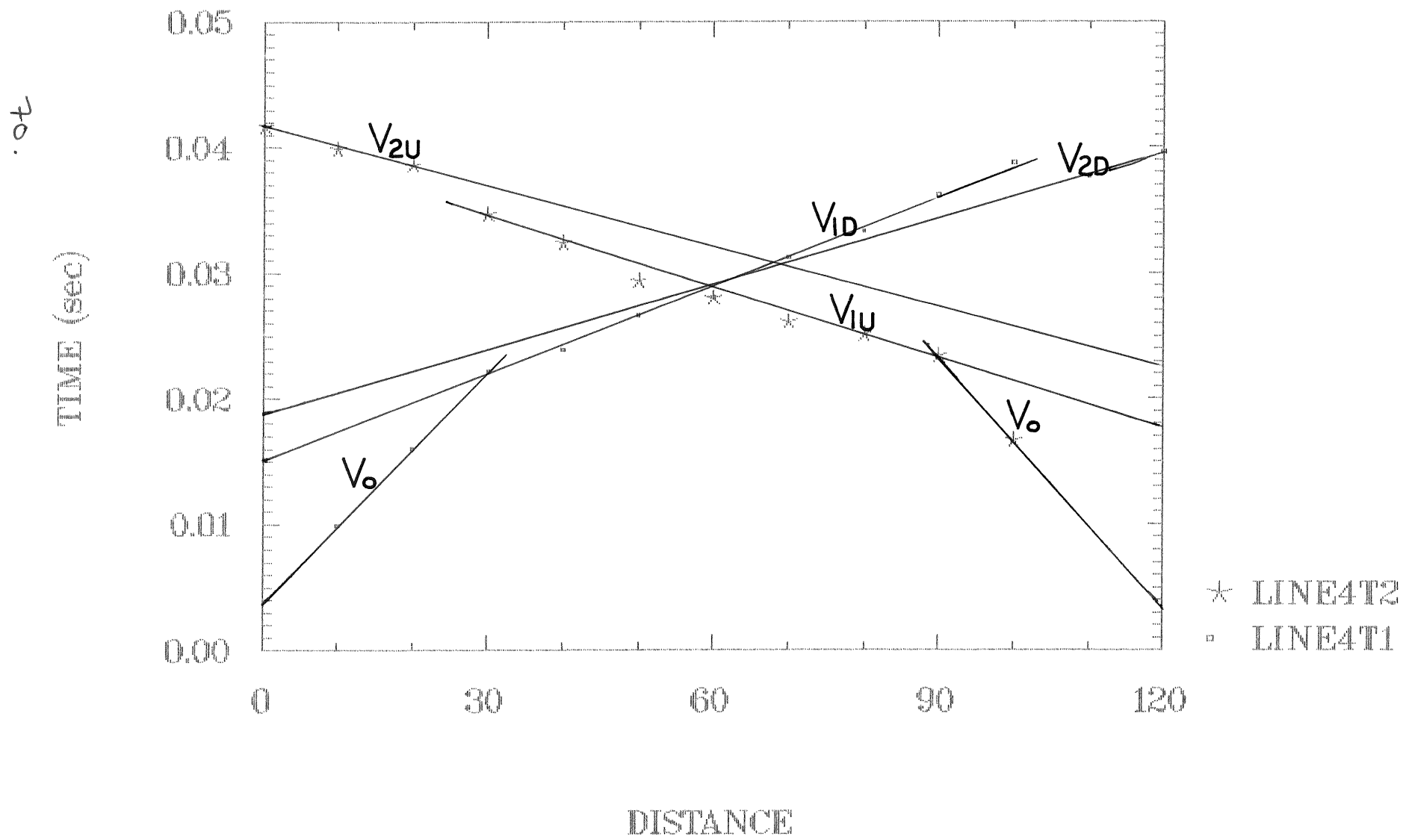

LINE #5

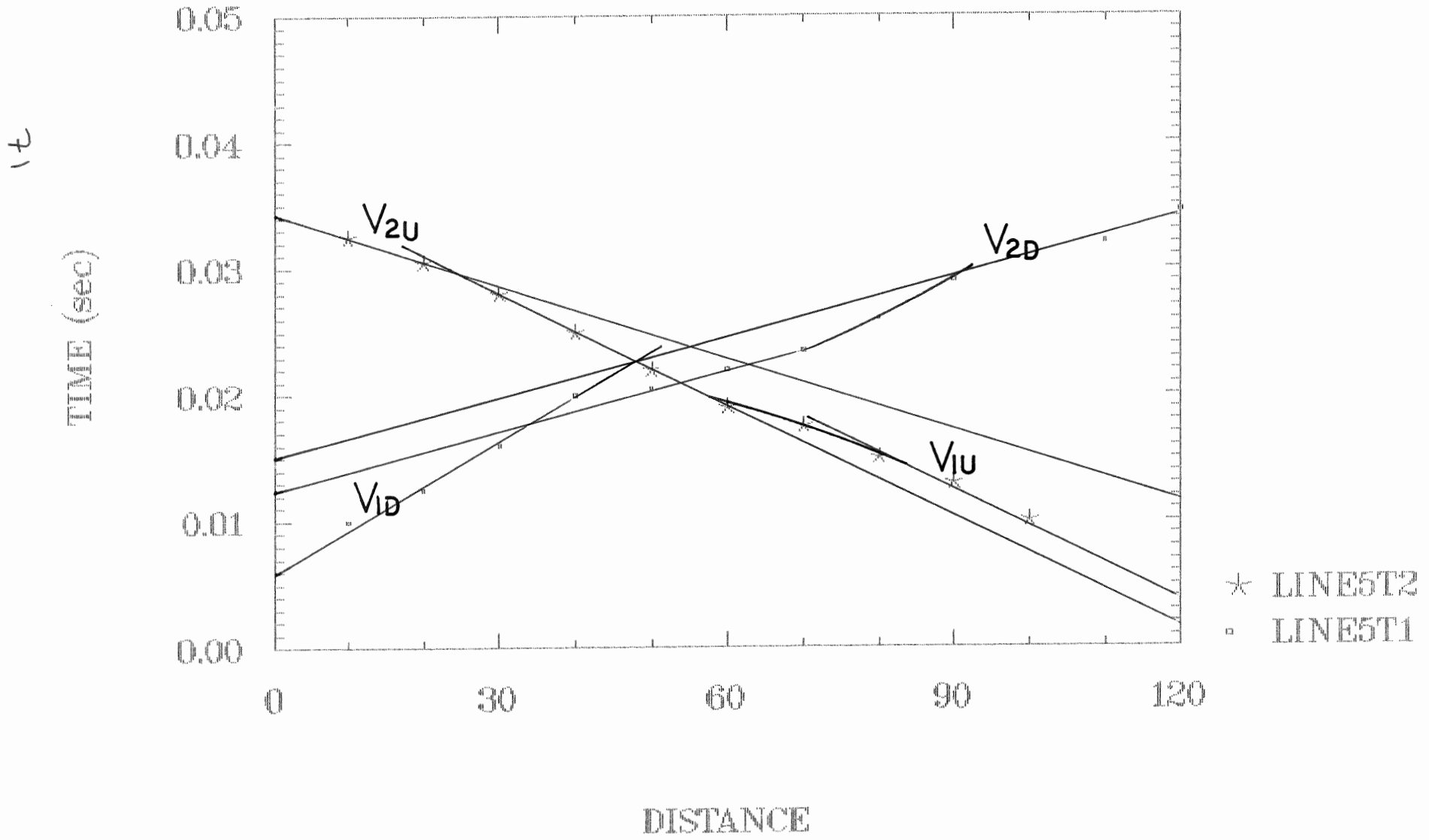

LINE #6

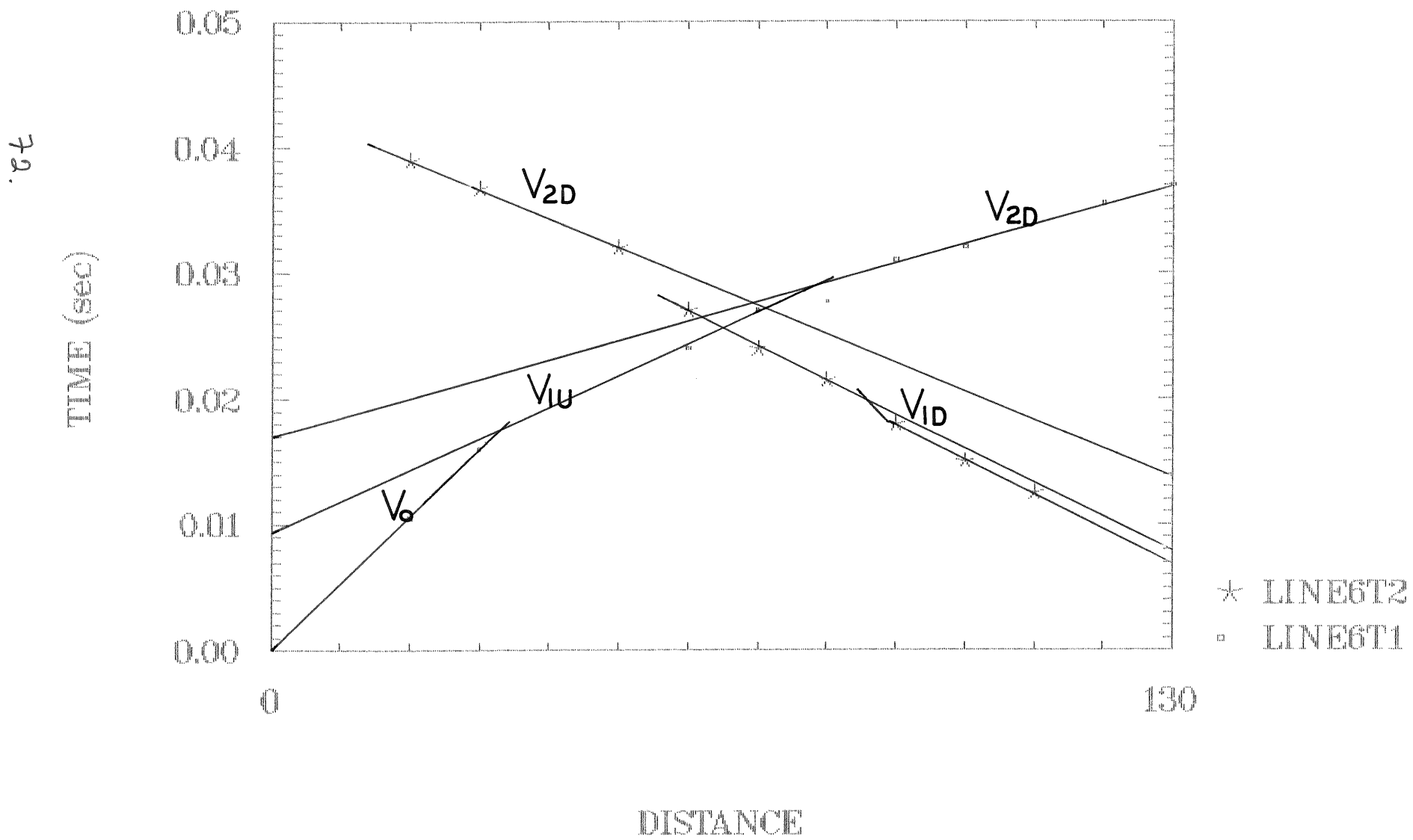

LINE #7

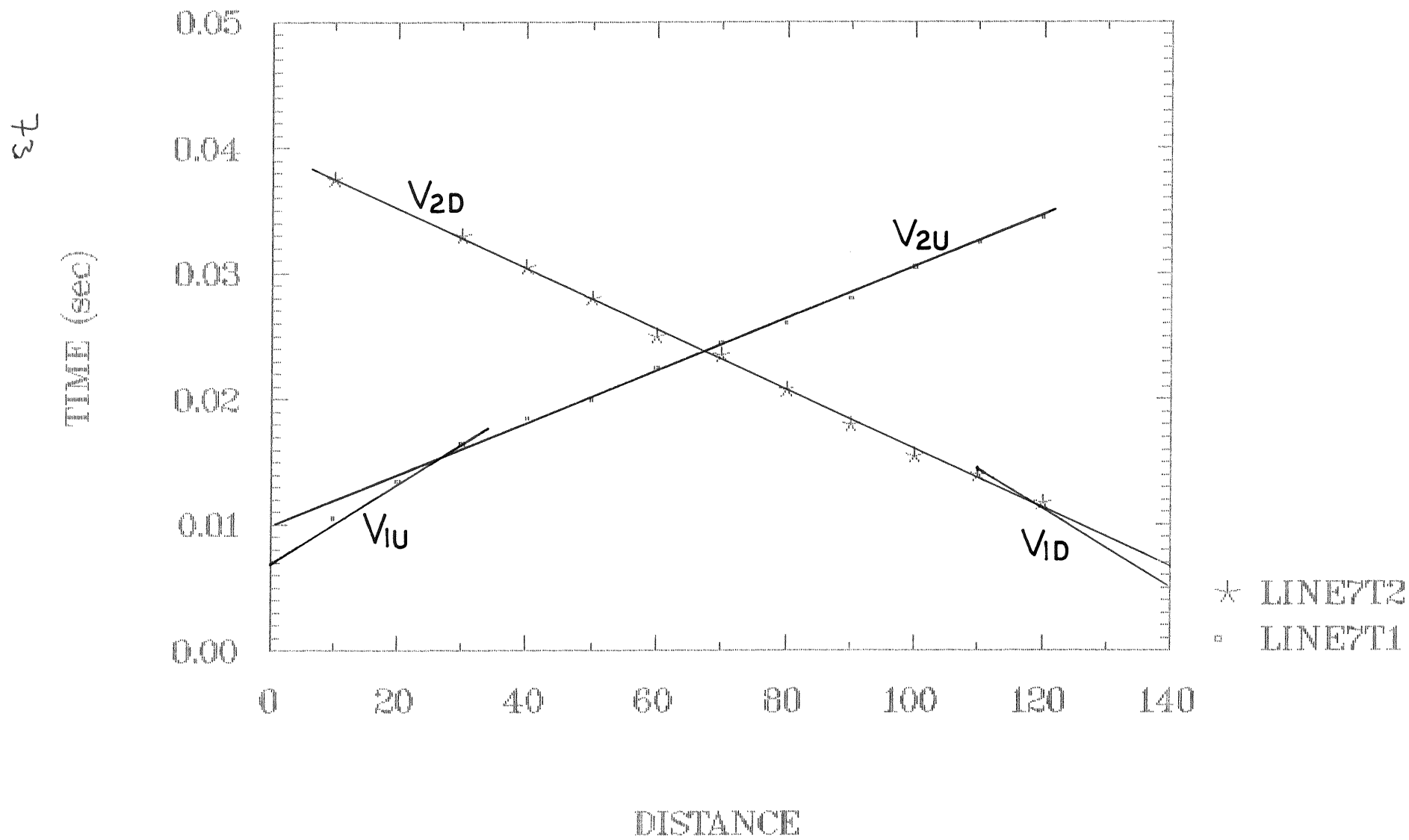

LINE #8

PH.

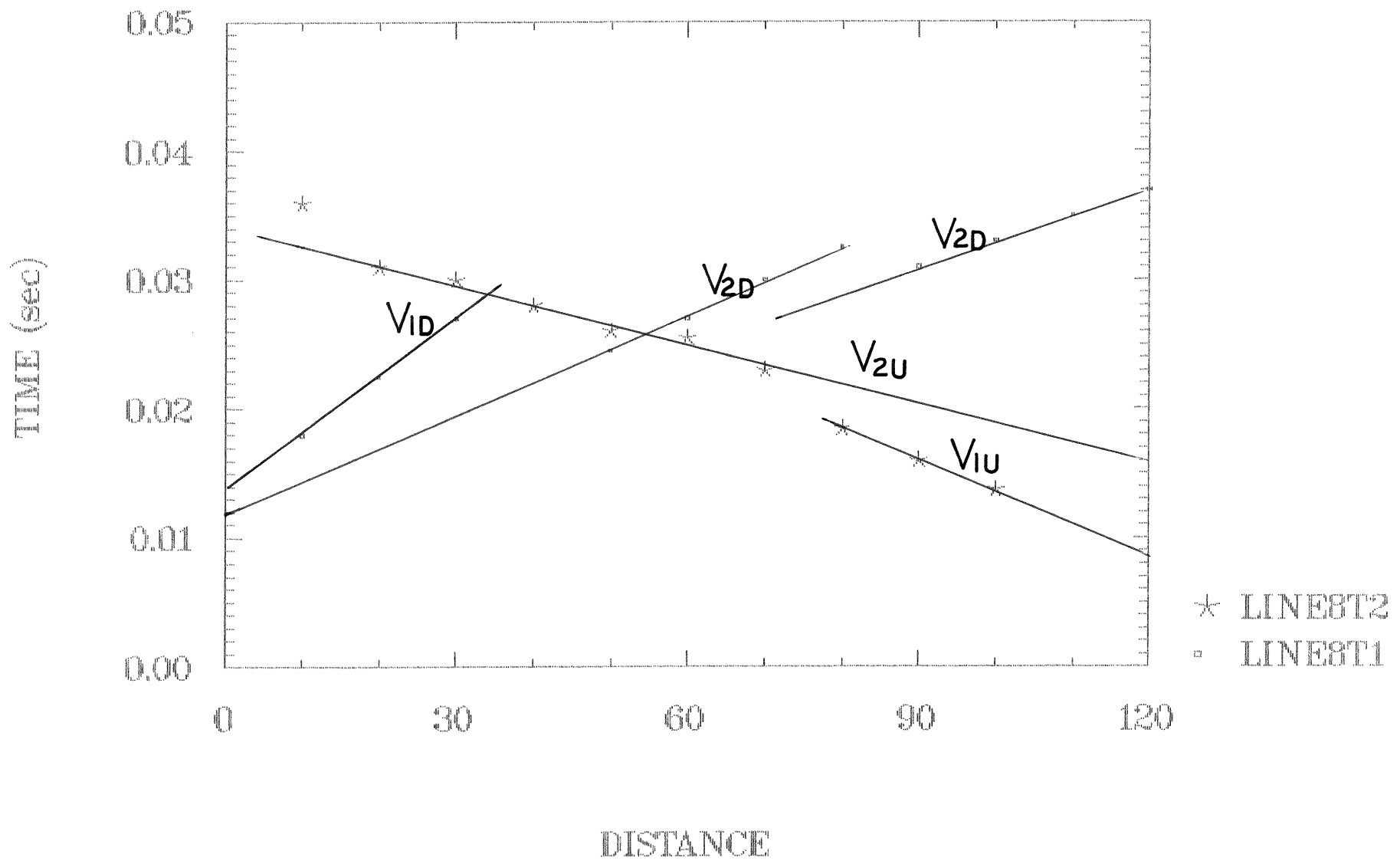

LINE #9

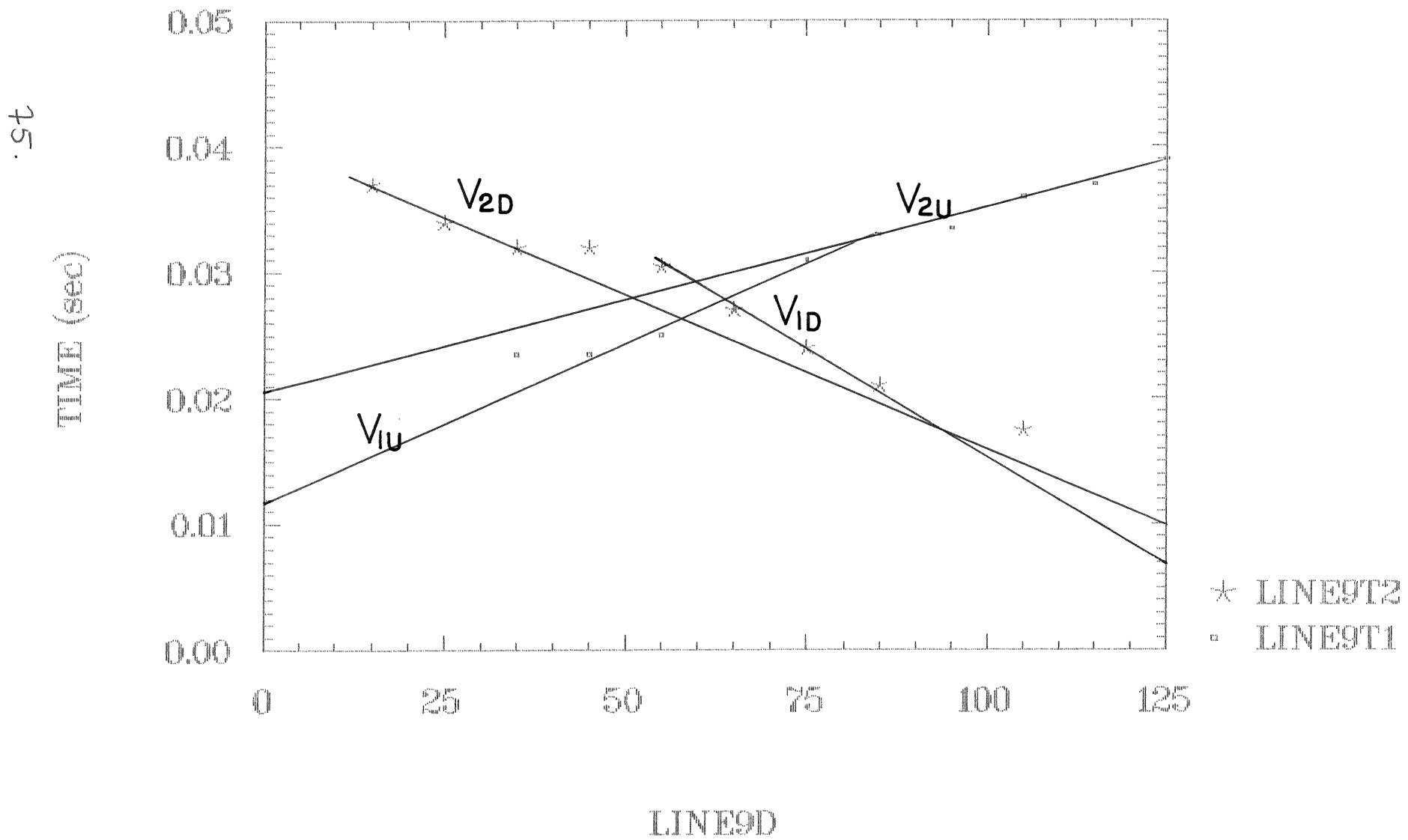

LINE #10

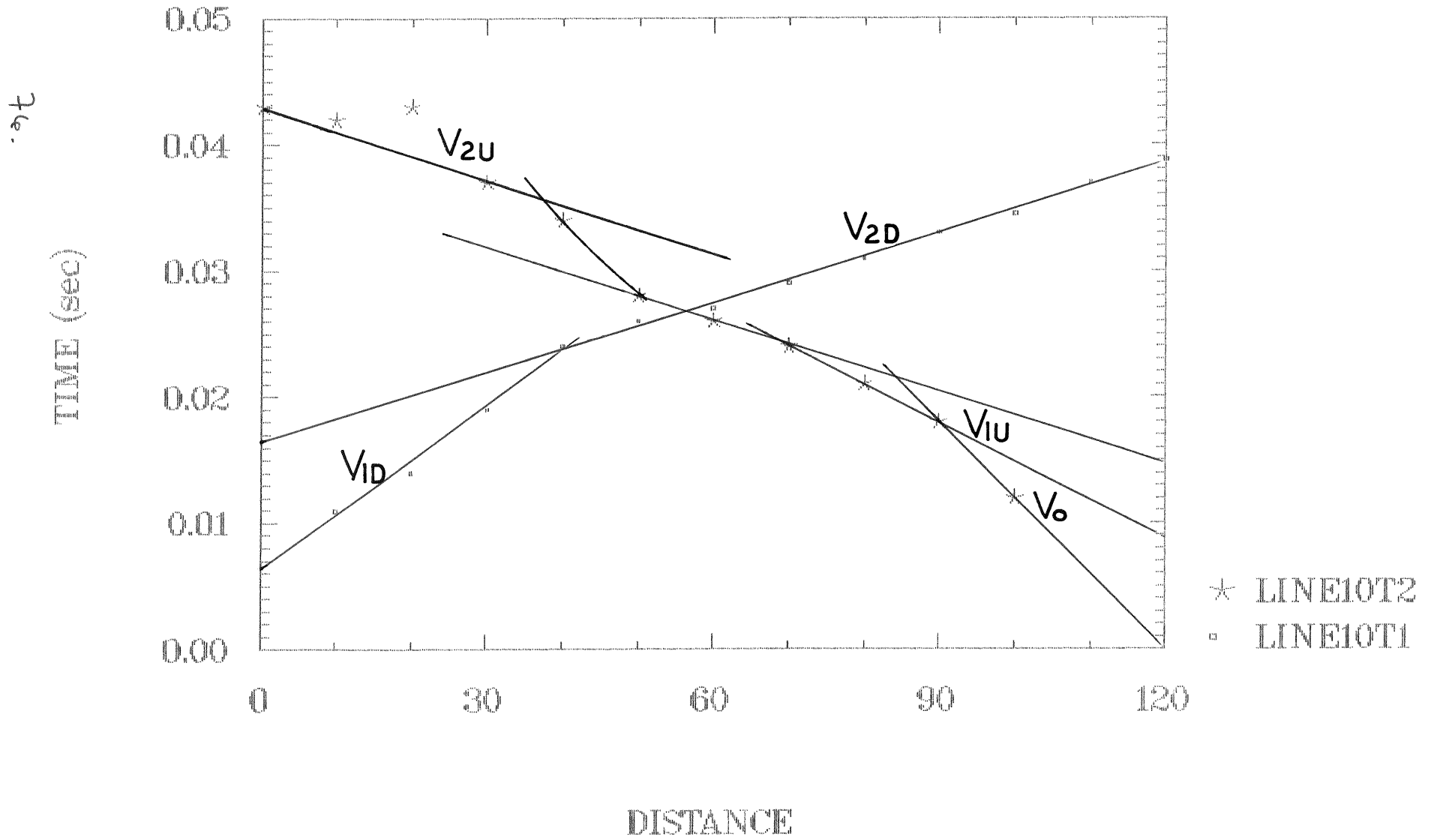

LINE #11

77.

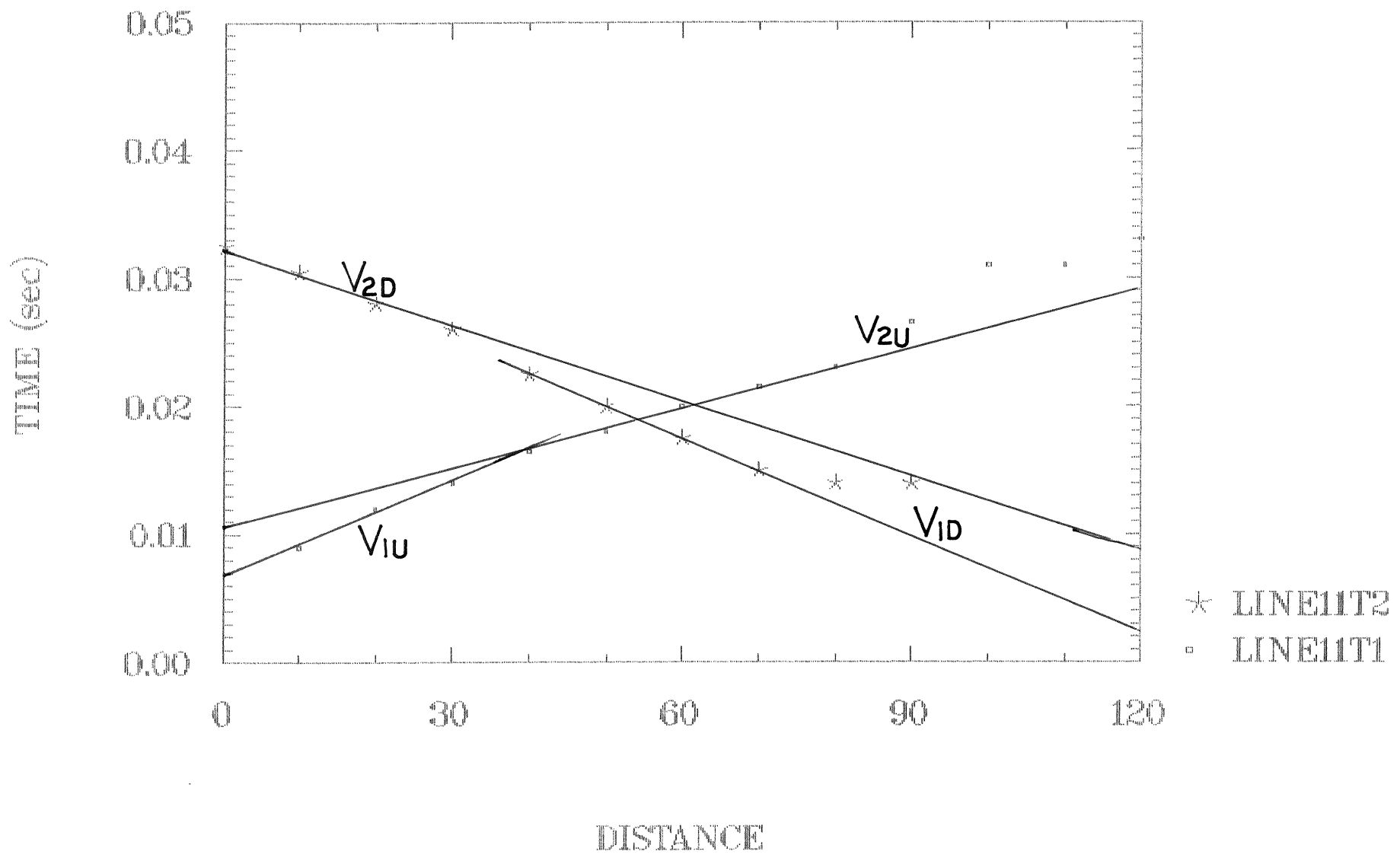

LINE #12

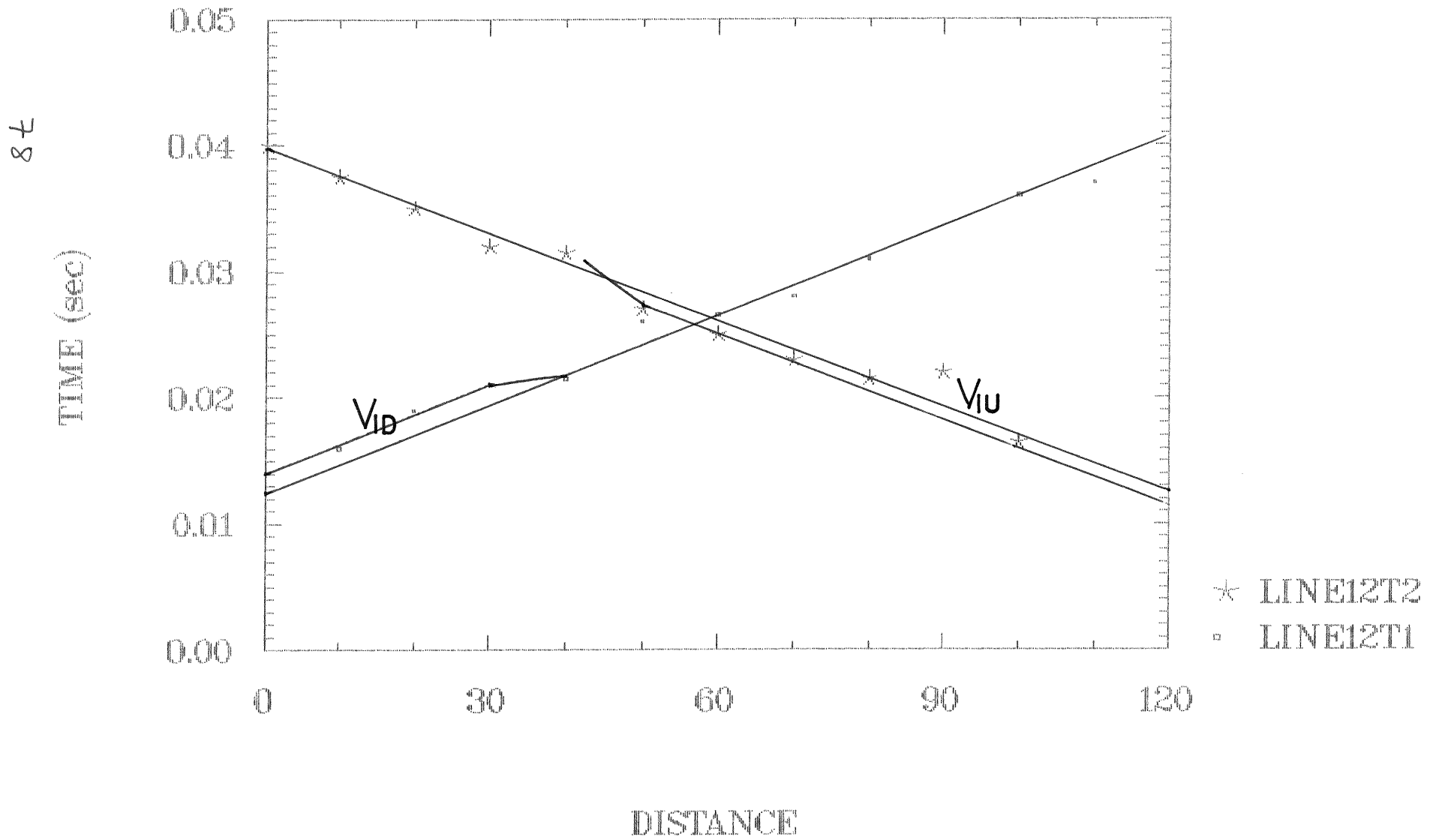

LINE #13

