

**Working Nomads: The Relocation of the Individual in a
Transient, Industrial Environment**

by

Fatima Rehman

Submitted in partial fulfilment of the requirements
for the degree of Master of Architecture

at

Dalhousie University
Halifax, Nova Scotia
March 2015

© Copyright by Fatima Rehman, 2015

CONTENTS

Abstract	iii
Acknowledgements	iv
Chapter 1: Introduction	1
Thesis Question.....	1
Chapter 2: Existing Conditions	3
Alberta Oil Sands: A Shifting Industry	3
Framing The Issue.....	4
Existing Work Camps	7
Closed Camps: Incubators for Social Isolation.....	9
Permanent Community Demographics	11
Government of Alberta Regional Growth Plan.....	12
The Case for Temporary Industry Related Inhabitation	15
Chapter 3: Theoretical Framework	17
Japanese Metabolism	17
The Nature of Flexible Dwelling.....	18
Re-enforcing Identity in a Fragmented Environment.....	21
Chapter 4: Design.....	23
Shifting Site Types	23
Site Parameters and Organizational Principles	29
System for (Re)Assembly.....	32
Public Modules	34
Dwelling Modules	41
(XL) Scale.....	41
Existing Community Scale.....	43
Remote Scale	44
Chapter 5: Conclusion	49
Bibliography.....	50

ABSTRACT

The lucrative development of the Alberta oil sands has created a unique settlement condition that has flooded the region with a temporary and dynamic work force. Current resource developers have developed an alternative to permanent settlement: remote, temporary, and mono-functional housing camps to support their ever-expanding, and contracting employment demands. By operating under the pretext of temporary accommodation, private companies construct and operate camps emphasizing cost, efficiency and portability. What is being overlooked is consideration of the human dimension. As a result, housing camps face a variety of social issues, including; vandalism, sexual harassment, and substance abuse.

This thesis is a study of the architecture and nature of temporary, industry related inhabitation. The intention is to “relocate” the individual in the process by developing a system of flexible organizational patterns, public, and private spaces, and to promote a sense of community in a transient environment that is often characterized as an isolating and dehumanizing experience.

ACKNOWLEDGEMENTS

I would like to thank Niall Savage and Diogo Burnay for their encouragement, enthusiasm and critique throughout the process. Your dedication to teaching and love for meaningful architecture have made a strong impression on me, and I am thankful to have had the opportunity to learn from you both.

Thank you Carolyn, Cait, and the rest of my studio family for your companionship, which kept me smiling and laughing throughout this journey.

Thank you to my family for your constant words of love and encouragement. I am very grateful to have had your support to move far from home to pursue my dreams and reach my goals.

CHAPTER 1: INTRODUCTION

Thesis Question

How can the introduction of incremental units of public space form a network of temporary inhabitation that fulfills a sense of community for transient inhabitants and permanent communities in the Alberta oil sands region?

The province of Alberta derives over one fifth of its revenue from the oil sands industry. The dominant and volatile industrial economy experiences 'booms' and 'busts' depending on market prices of oil.¹ This method of operation results in the need for a flexible and diverse workforce to plan, construct, and operate an industry that is vastly spread across northern Alberta. There are thousands of people currently residing in temporary closed camps outside Fort McMurray; the region's main urban centre. Workers from many trades are flown in from all over the country to work at remote sites for 20 days on and 7 days off. This migration of workers has little positive impact on permanent communities and residents in the region. Large municipalities feel the pressure of a population on their infrastructure, and smaller communities lack the infrastructure to begin with. In addition, the day to day life of the transient worker is solely dictated by industry, and the temporary buildings that house residents compound notions of exclusion and disconnection.

This thesis intends to explore the unique housing needs associated with the changing conditions of resource development in the Alberta Oil sands region. It intends to combat feelings of anonymity, isolation and a lack of

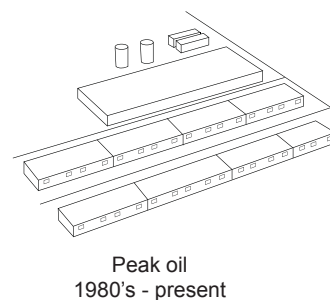
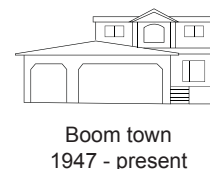
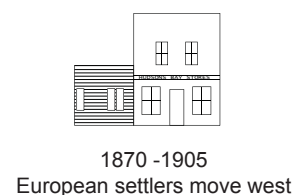
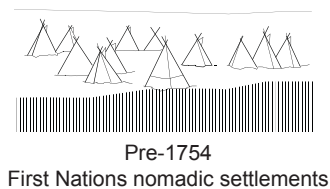

1. Jeff Lewis and Jeffrey Jones, "Under Pressure in the Alberta Oil Patch," *The Globe and Mail*, (February 20, 2015): 1.

belonging experienced by the majority of the transient workforce. Lastly, this thesis seeks to address the physical, and social barriers that exist between small rural communities and transient communities of workers.

The design proposal recognizes the place for temporary architecture in the region and proposes a demountable, modular system of private, and public spaces whose components are adaptable, and responsive to various site types. Pockets of public space will be carved out at the urban, collective, and personal dwelling scale. Multiple dwelling modules will be combined, creating a void for shared amenities including; recreation, cultural space and community kitchens, to occupy. The void spaces will be accessible by both transient residents, and permanent communities. This new typology of public space has the potential to remain in use by residents long after the industry has shifted phases, creating a positive impact on rural and transient communities in the region.

CHAPTER 2: EXISTING CONDITIONS

Alberta Oil Sands: A Shifting Industry

Approximately 350 kilometres north east of Edmonton Alberta resides an expansive, and established network of unpaved roads, extraction plants, hospitals and temporary housing camps, all of which are a product and legacy of privately owned energy companies. The Canadian economy is heavily if not solely reliant on the existence and success of these companies, meaning a long time tradition of corporate constructs continues, where private enterprises are given full autonomy with little government regulation to establish and run these facilities.

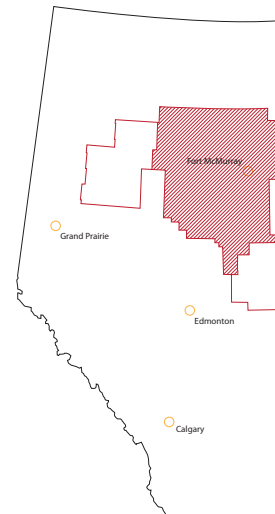

Map of the Athabasca oil sands region, 2014; map from Government of Alberta, "CRISP AOSA"

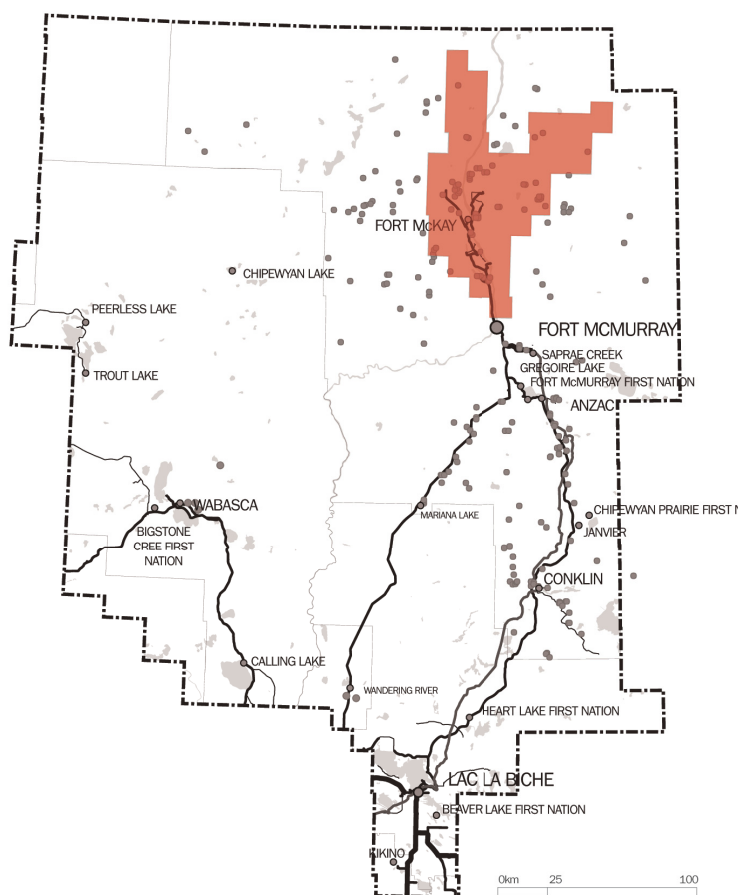

Map of the surface mineable area in the Athabasca region, 2014; map from Government of Alberta, "CRISP AOSA"

The Alberta oil sands since its beginnings in 1967, make up the single biggest private investment in Canada, with 170 billion barrels of oil in underground deposits.² In addition to providing economic gain through international exports, the industry of extraction, refinement, and pipeline construction employ thousands of Canadians from across the country. The region has had to grapple with a booming economy, and an influx of permanent residents and temporary workers, which in turn puts strain on existing communities and infrastructure. A transient travel to where the work is lifestyle is a reality for thousands of Canadians temporarily residing in the region. This unique reality of modern nomadism, is where this architectural thesis begins.

Framing The Issue

Over the last ten years, the northern Alberta town of Fort McMurray has grown to be a sprawling bedroom community of 70,000, and service hub for workers of the Athabasca oil sands. In 2006 it boasted a conservative population of 20,000 souls. Municipal planners are struggling to meet the infrastructure needs for new migrant communities, as well as cope with outstanding needs of long time residents. The average age in town is young; 31.6 years. The local airport sees close to 1.3 million travellers through its doors yearly, with over 240 000 workers flying in on company chartered planes.³ In addition to its sprawling population, it is estimated that a 'shadow' population of 39,000 – 80,000 workers live in nearby camps, exhausting amenities like hospitals, roads, and Tim Horton's. There have even been reports of

2. Shawn McCarthy, "Why the Oil Sands matter to every Canadian," *The Globe and Mail*, (October 28, 2014): 1.

3. Jeff Lewis, "Fort McMurray cracks under oil boom's strain." *The Globe and Mail*, (October 28, 2014): 1.

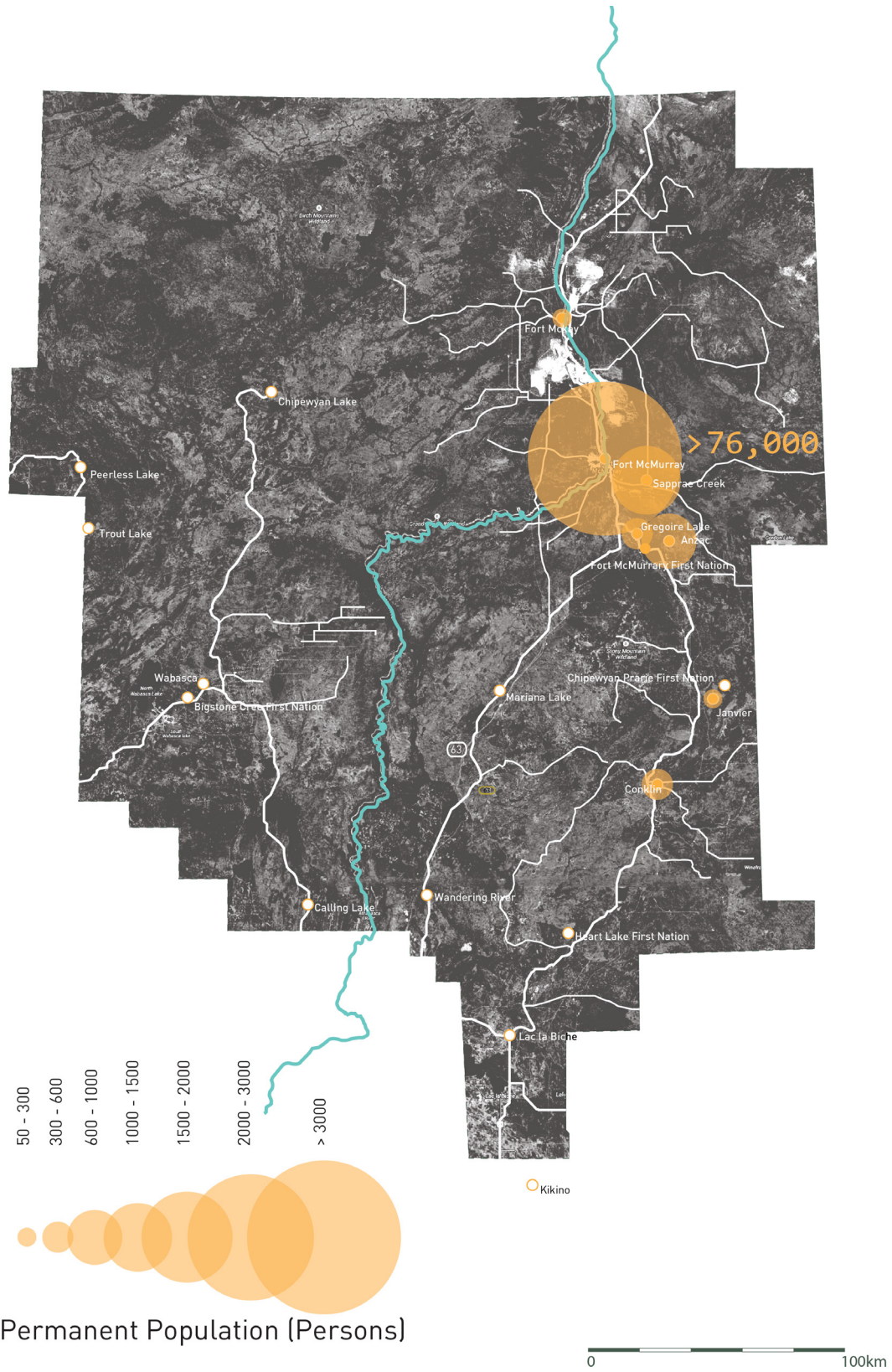

Map of established community populations and locations, 2013; data from Google

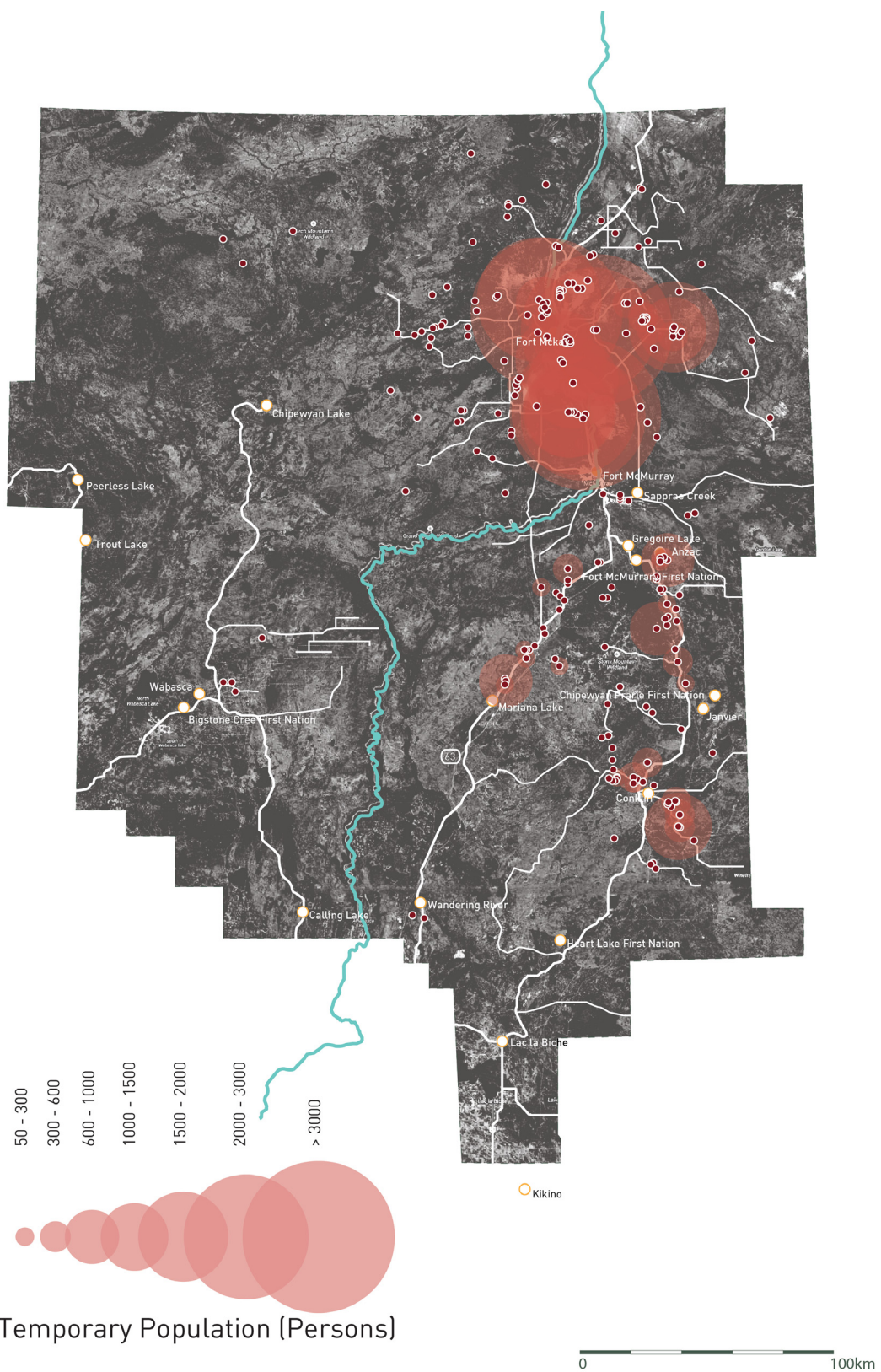

Map of estimated population and locations of temporary camps, 2013; data from Google

increases in local food bank use in the last several years. The city's housing and infrastructure are being pushed to their maximum, and temporary work camps provide a short lived sigh of relief to a strained community.⁴

Industry related temporary work camps, are an alternative to single industry driven boom towns, that have since been abandoned or fallen into disrepair after industry left. Current resource developers have established remote, mono-programmatic temporary housing camps to support their fluctuating and shift based employment demands. The fact that the infrastructure, and architecture is conceived as temporary, allows private companies to construct and operate camps emphasizing cost, efficiency and portability as leading factors in design decisions.⁵ What is being unconsidered is the human dimension, and the social ramifications of working and living in these camps.

Existing Work Camps

There are currently over 200 operational temporary work camps in the Athabasca region, and their populations vary from 60 person camps to over 5000 person camps. The shifting nature of these camps make it difficult to pin point exact populations that make up this unique form of inhabitation. What is consistent between work camps is the separation of program on site. A typical work camp is organized around allocating a maximum number of sleeping dormitories. Collective amenities take the back seat.

4. Lewis, "Fort McMurray cracks under oil boom's strain." 1.

5. Kelly Doran, "Scraping for Oil: The Vast Reconfigured Landscape of Alberta's Athabasca Oil Sands is Largely Hidden from View, Remaining a Mystery to Designers," *Canadian Architect*, (2009), <http://www.canadianarchitect.com/news/scraping-for-oil/1000228228/?&er=NA>.



Typical corridor entrance to individual dorms

Dorm (private) : 13 415 sm 74%



Circulation (shared): 1036 sm 7%



Dining (shared) : 940 sm 6%



Recreation (shared): 460 sm 5%



Support/Prep (shared) : 1215 sm 4%



Office/Admin (private) : 780 sm 2%



Utilities: 402 sm 2%



Total Camp area: 18 248 sm

Parking: 7052 sm

Program distribution in a typical camp, data from Black Diamond Limited

Closed Camps: Incubators for Social Isolation

Sunday Creek Lodge is an example of a 1100 man camp. A central check in, dining room, full service kitchen, and two recreation units are linked to private dormitories by a covered arctic corridor. This facility also has its own well, water treatment plant, waste water treatment plant, and is serviced by a neighboring community's electrical grid. All of it's food and waste is trucked in and out on a weekly, and daily basis respectively. All waste is transported by truck to the Fort McMurray landfill. Furthermore, management, blue collar workers, tradespersons, and hospitality staff all occupy segregated dormitories. These isolated dormitory blocks, typically housing 30 to 40 inhabitants in each, are physically separated from dining, and recreational spaces by either harsh climate, or narrow corridors. The confinement of space, compounded by the transient 2 or 3 week shifts completed by inhabitants, who are usually far from where they call home leads to isolation, and apathy amongst the population.



Fort McMurray has an overall crime rate 5X the provincial average, photo by Ian Willms, "A day in Fort McMurray," *The Globe and Mail* (Oct. 29, 2014)



Photograph of a typical temporary camp, 2014; photograph from Black Diamond Limited



1 dormitory
sleeps 44
persons on
average



x 11

This camp
sleeps a
total of 1100
persons

- Recreation Rooms
- Dining Hall
- Kitchen
- Offices
- Circulation Corridor
- Entry
- Waste Water Treatment
- Fresh Water Storage
- Back Up Fuel Tank
- Above Ground Utilidor

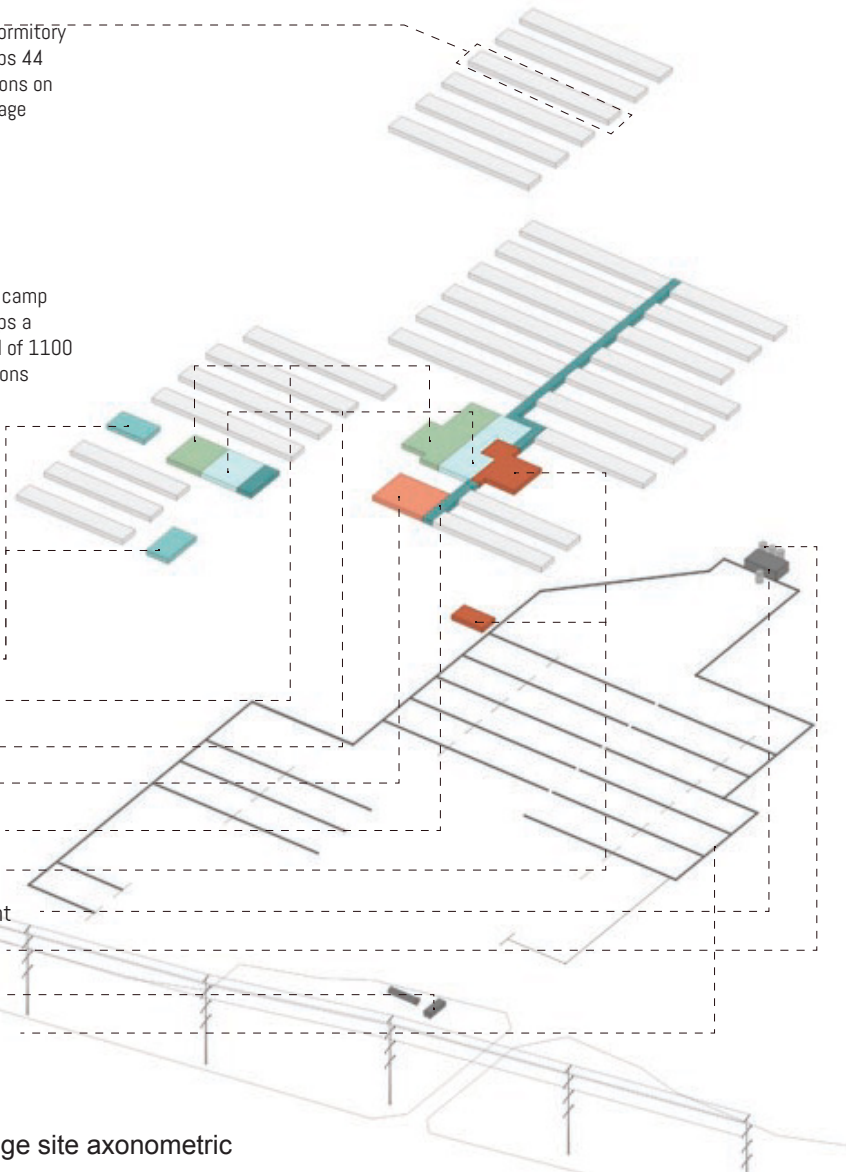

Sunday Creek Lodge site axonometric

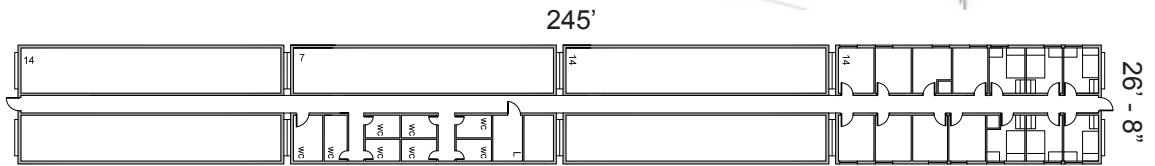

Typical 44 person dormitory plan

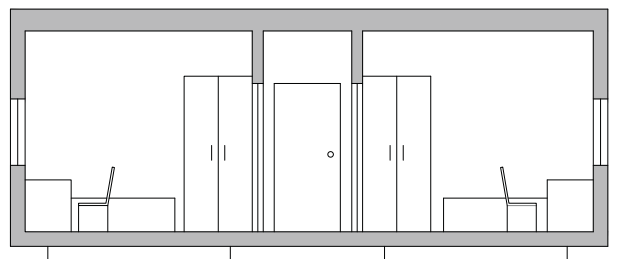

Typical section through dormitory

Management of these facilities argue that the geographic limitations of work camps, and the harsh climate that delineate constricted circulation and access in combination, create a situation of control that suppresses substance abuse problems and increases productivity.⁶ In reality, the increasing prevalence of drug and alcohol abuse, is in fact connected with a sense of isolation felt by transient workers who spend their time in closed camps. The current approach of temporary work camps can also be contributed to the modernist legacy of normalization. Housing is manufactured with minimum requirements in mind, to serve the greatest number of people, and the process of mass production speaks to the greater context of over consumption and waste the camps support.

Permanent Community Demographics

Permanent communities in the Athabasca and Wood Buffalo Region, excluding the urban centre of Fort McMurray are primarily rural hamlets of 800 persons or fewer. Conklin has a permanent population of 337 people, and approximately 3 km away is a temporary work camp. This type of condition is common in the region, companies prefer to build exclusive accommodation for their employees to facilitate ease in transporting workers to site. Proximity to existing communities also allows shared use of utility grids. The oil sand industry makes up 37% of employment in rural communities, whereas industry employment in urban areas in the region reaches 53%.⁷ Rural communities in the region have large aboriginal populations, compared to their municipal counterparts whose population is primarily

6. Charlie Hailey, *Camps: A Guide to 21st Century Space* (Cambridge: MIT Press, 2009), 302.

7. Wood Buffalo Municipal Census 2012, 95.

Caucasian, but with steadily growing South and Pacific Asian populations.⁸ The diversity that exists in hamlets and major urban centres in the region is also reflected in the inhabitants of temporary work camps.

The needs of rural communities vary from hamlet, to hamlet depending on population size, and access to government funding for infrastructure projects. It is clear that the stronger of a relationship a rural community has with resource development in the area, the more likely infrastructure and housing needs can be met. Fort McKay is a hamlet of less than 500 persons with over 90% of an aboriginal population. It has embraced industry, and the hamlet has prospered as a result, building community facilities and recreational amenities.⁹ Other hamlets are not as fortunate and continue to witness the barrier between the amenities provided for transient workers, and the needs of their own communities. This thesis recognizes the possibility to integrate community, and housing infrastructure for existing residents within the design proposal for temporary housing, benefiting both types of communities.

Government of Alberta Regional Growth Plan

Oil sand related employment is concentrated south of the Surface Mineable Area, approximately 30 km north of Fort McMurray. The majority of the employment in this area is comprised of operations, and construction activity. Two thirds of the population in the region resides in Fort McMurray, and over 10 percent are living in work

8. Ibid., 55.

9. Kelly Cryderman, "The dispute the entire oil industry is watching," *The Globe and Mail*, (December 14, 2013): 1.



Community of Fort McKay, showing prevalence of community amenities



Community of Conklin, showing limited community amenities

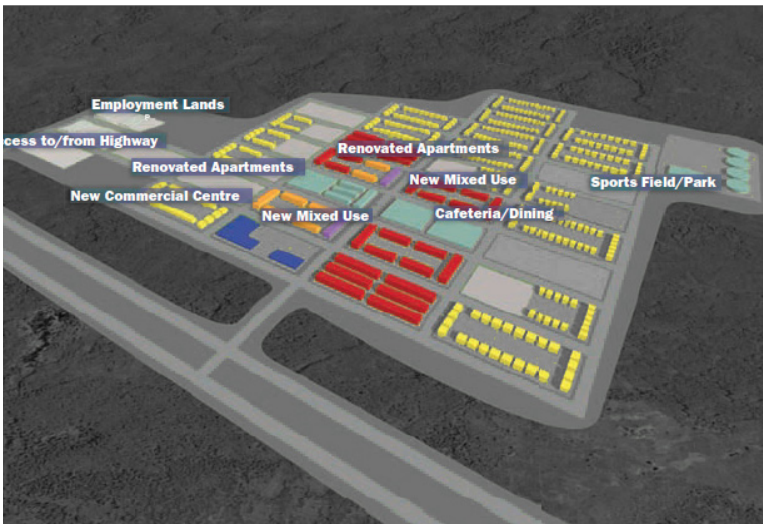
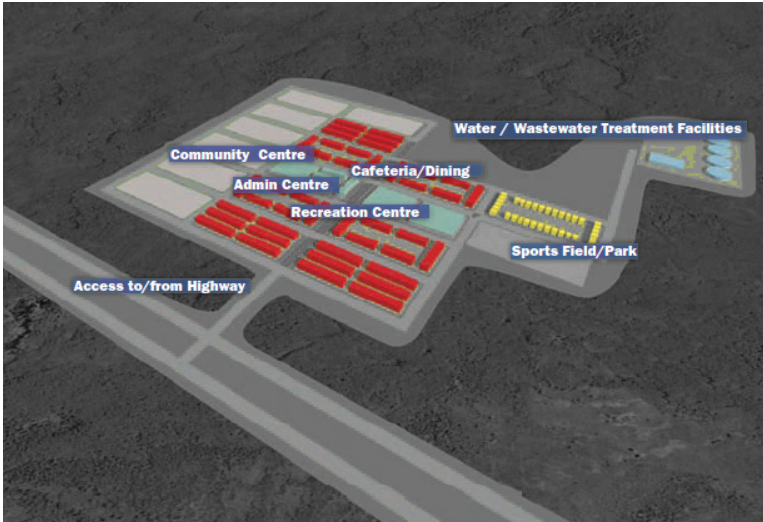

Phased development of planned camps, 2014; map from Government of Alberta, "CRISP AOSA"

camps.¹⁰ By 2045 there will be 10,200 persons in planned camp communities, and 42,300 in the New Urban Growth Nodes.¹¹ New Urban Growth Nodes have been proposed by the Alberta government as an alternative and sustainable approach to the housing crisis in the Athabasca region. The intention is that fewer workers will have to work in traditional temporary camps, and emphasis will be placed on housing these workers and their families in existing communities, and new planned camps.¹²

The Comprehensive Regional Infrastructure Sustainability Plan outlines planned work camps, that would initially house temporary workers primarily working in construction industries. These camps would be planned from the start, allowing for greater flexibility in the future to serve long-term communities for operations staff, and their families. The report states that these planned camps would be strategically located along a highway corridor, and thus minimize commuting times to multiple project sites. They would be planned in such a way to allow for growth to occur, housing would be built to a higher standard and greater recreational, educational and family oriented amenities would be included.¹³ The notion of urban growth nodes and planned temporary camps proposed by the Government of Alberta express the existing desire to rethink industry related inhabitation.

The transient population of workers in the region are worthy

10. Government of Alberta, "CRISP AOSA: Comprehensive Regional Infrastructure Sustainability Plan for the Athabasca Oil Sands Area," 46, last modified April 2011, <http://www.energy.alberta.ca/Initiatives/3240.asp>.

11. *Ibid.*, 7.

12. *Ibid.*, 42.

13. *Ibid.*

of a thoughtful approach to their unique condition. Although the Alberta government is encouraging and proposing a shift towards nodes of temporary development that evolve into permanent communities, the needs of temporary workers in the region are still present, and the way in which they are housed currently poses opportunity for further design. In order to frame the argument for continued nomadic living around the development of the Athabasca oil sands, one must look at the nature of industry related inhabitation.

The Case for Temporary Industry Related Inhabitation

The changing nature of the oil sands industry is a crucial point in making the case for temporary inhabitation in the region. Since the 1970's the region has been ramping up construction of roads, pipelines and refineries. The peak of resource extraction is set to be reached by the year 2080, after which sites will shift to an operations based phase, requiring reduced man power. In the post peak period land reclamation will be increasing, and the region will again face new employment demands and losses. The fluctuating character of the industry demands a flexible, and shifting creature of architecture.¹⁴

The future of the region is expected to see continued job growth in the north eastern parts of the surface mineable region, Fort McMurray will continue to be the primary service hub for the region and attract population growth. If the city was to accommodate the estimated employment projections it would double in population to a size of 145,000 during the

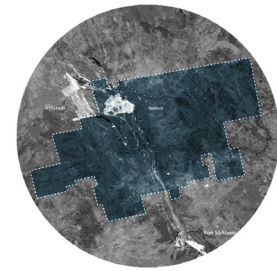

1974

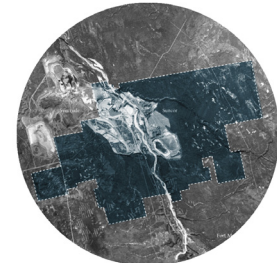

2004

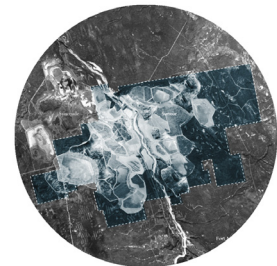

2036



2080

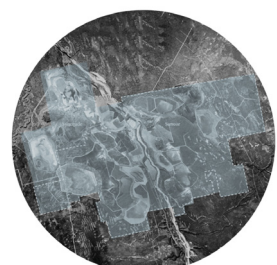

Post -Peak

14. Kelly Doran, "Operational alternatives: (Re-)configuring the landscape of Alberta's Athabasca oil sands," in *Sustain and Develop*, ed. Joshua Bolchover et al. (New York: Princeton Architectural Press, 2009), 40.

Projected evolution of industry development, data from Kelly Doran, "Operational Alternatives"

peak oil period. In addition to the pressure this would place on roads and services the location of jobs will be outside of reasonable commuting distances.¹⁵ Traditional work camp populations would increase to 20,000 - 25,000 during the peak oil period, or alternatively, the increase in population would be absorbed into new urban growth nodes located in proximity to the northern surface minable region. However, what would permanent development mean to the remote region after peak oil, approximately 60 years from now?

This thesis proposes that due to the very real and tumultuous nature of resource extraction, a temporary and flexible system of settlement is the most sustainable, and appropriate approach to industry related inhabitation, for both transient communities working in the oil sand industry, and neighboring permanent communities. The position of this thesis is that temporary architecture can adapt to the shifting economic needs of the industrial region, and provide a sustainable alternative to permanent settlement, all without losing sight of the possibility of community.

15. Government of Alberta, "CRISP AOSA," 46.

CHAPTER 3: THEORETICAL FRAMEWORK

Japanese Metabolism

The contemporary need and search for alternatives to permanent settlements is not new. The Japanese Metabolists looked to find catalysts for new forms of urban development that addressed issues of land scarcity, housing shortages, and unplanned sprawl. They conceived of organizing a city around strict private and public spaces, where large infrastructural components make up one part of the city, and private spaces form a landscape of modular cells in between. This meant that populations had an increased sense of mobility within the city. Furthermore, they conceived society as being unbound to place.¹⁶ This notion is relevant to the discussion of temporary architecture for Northern Alberta work camps as it is an precedent for moving populations and architecture.

In addition, the Japanese Metabolists had an aversion to the conventional relationship between architecture, and the ground it sits on. Specifically, Japan's ground was either too densely populated, expensive, environmentally sensitive, or unstable to build upon. Therefore, an alternative 'artificial ground' was conceived where structures would hover over the ground on pilotis or a platform. The uniqueness of the ground condition was seen as an opportunity for speculation. A member of the group, Kawazoe makes this point by stating: "The very difficulty of obtaining land is actually unfolding a new possibility for housing..."¹⁷ In Capsule Village, dwellings of leisure are suspended above a hillside through the use of

16. Meike Schalk, "The Architecture of Metabolism. Inventing a Culture of Resilience," *Arts* 3, no. 2 (2014): 281.

17. Rem Koolhaas and Hans Ulrich Obrist, *Project Japan: Metabolism Talks* (London: Taschen, 2011), 340.

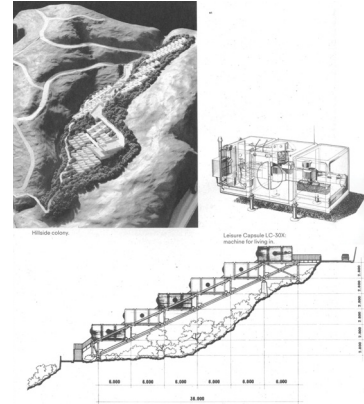

Capsule Village, 1972; from Koolhaas, and Obrist, *Project Japan: Metabolism Talks*

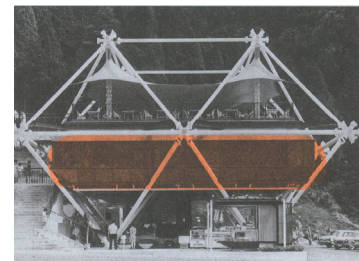

Odakyu Drive-in Restaurant, 1969; from Koolhaas and Obrist, *Project Japan: Metabolism Talks*

a scaffold structure that protects the vegetation below. In the Odakyu Drive-In Restaurant, a modular space frame is utilized to allow for growth through the use of prefabricated extension joints, creating the opportunity for a constantly expanding and contracting urban structure.¹⁸

The Metabolist concept of Proliferation and Colonization addresses the uncertainty of ground conditions by proposing megastructures, that adapt to their conditions by adding and removing modules depending on economic or social need. Allowing for the possibility of exponential growth within a flexible framework.¹⁹ The Mina Pilgrim City is an example of this symbiosis. Conceived by Kenzo Tange and Ekuan, it is particularly relevant to this thesis as it consists of a packable and retractable city of components. Situated halfway between Mecca and a pilgrimage site, the city would be erected to accommodate pilgrims, and dismantled after the pilgrimage is over, maintaining the sacredness of the site. All components would be demountable, and repacked to be stored at the base of the hills until needed again.²⁰

The Nature of Flexible Dwelling

“The way we reside is increasingly being set in motion. This social transformation, often not easily processed by those affected, is more over unfolding at a pace that generates feelings of uprootedness, loneliness and a loss of meaning.”²¹ This condition is outlined by Stephan Rammler,

18. Ibid., 347.

19. Ibid., 346.

20. Ibid., 351.

21. Stephan Rammler, “A Mighty Fortress...On the Sociology of Flexible Dwelling,” in *Living in Motion: Design and architecture for flexible dwelling*, ed. Mathias Schwartz-Clauss et al. (Ditzingen: Vitra Design, 2002), 199.

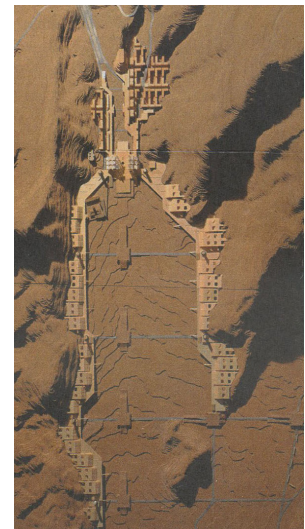
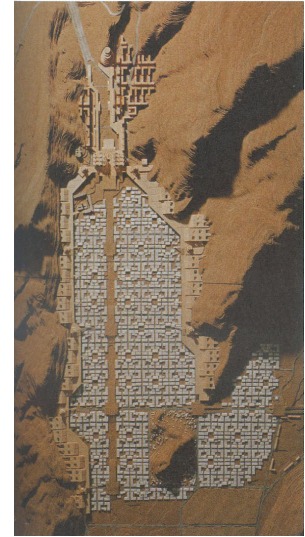

Mina Pilgrim City, 1974; from Koolhaas, and Obrist, *Project Japan: Metabolism Talks*

who contributes this phenomena to a globalized society that demands frequent relocations, flexible housing forms, and in some cases a routine nomadic existence.

The distinction between settlers and nomads in western culture has resulted in the exclusion of huts, tents, yurts and igloos from the notion of architecture. However mobile, and flexible domestic elements have existed in western domestic spaces since antiquity, fading into shadow and re emerging particularly during the modern movement of the 20th century. “Today more than ever, the progressively overlapping spheres of work and home, as well as the increasing importance of mobile, unconstrained and flexible lifestyles cause us to search for living options that are independent of fixed patterns and predetermined locations.”²² This statement expresses that there are clear needs for alternatives to permanent dwelling.

Robert Kronenberg states that establishing a personal, identifiable home-like place is dependent on the ability to modify ones surroundings. In his reading of Martin Heidegger, Kronenberg recognizes that the process of making a building is what creates dwelling, and gives meaning to place, but relents that permanence is not the only way to inscribe meaning. He cites the Japanese landscape as recognizing passage, and place through the placement of rocks and encircling trees with rope, and indigenous traditions of defining place by taking the same route described in oral histories as examples of impermanent place making. Furthermore, he states that the process of making a home

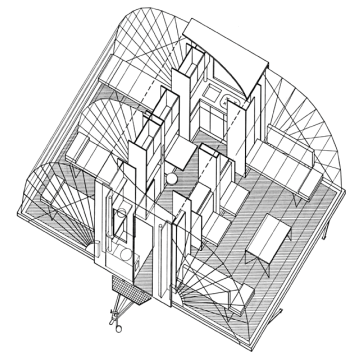

Eduard Bohtlingk Markies, Camper with fold-out rooms, 1986; from Schwartz-Clauss, *Living in Motion: Design and architecture for flexible dwelling*

22. Mathias Schwartz-Clauss, “Dwelling on Living in Motion - an Introduction,” in *Living in Motion: Design and architecture for flexible dwelling*, ed. Mathias Schwartz-Clauss et al. (Ditzingen: Vitra Design, 2002), 12.

is not a finite act, but rather a ‘transient and continuously developing act’.²³

Nomadic elements arguably already exist in a domestic setting, the partition screen acts not only as a piece of furniture, but as an element of architecture in the form of flexible, and mobile walls. A central concern of the early modern movement was to introduce dynamic qualities into the domestic environment. Flexible furniture, spaces and objects create a level of engagement with ones surroundings in a more meaningful way than the switching on of a light, or opening of a window.²⁴ The ability to rearrange your surroundings according to mood and circumstance suggests an inherent relationship to one’s built surroundings.

The possibility of flexible personal space for transient workers could create a stronger feeling of belonging in a temporary community. Personal space in isolation would not achieve this, but in addition to public spaces, greater autonomy over ones own surroundings could contribute to a sense of ones place in a temporary environment. Flexible and changing personal furniture could be a way of creating ownership for transient inhabitants in the region.

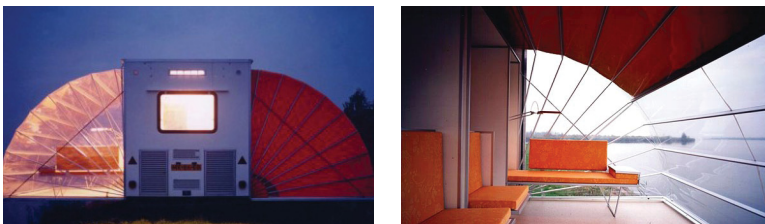

Eduard Bohtlingk Markies, Camper with fold-out rooms, 1986; from Schwartz-Clauss, *Living in Motion: Design and architecture for flexible dwelling*

23. Robert Kronenburg, “Modern Architecture and the Flexible Dwelling,” in *Living in Motion: Design and architecture for flexible dwelling*, ed. Mathias Schwartz-Clauss et al. (Ditzingen: Vitra Design, 2002), 22.

24. Ibid.

Re-enforcing Identity in a Fragmented Environment

Nikos Papastergiadis in his book on the turbulence of migration states that cultural Identity, in the context of the migrant's journey needs constant ritualization, and performance for it to maintain, and strengthen its presence in an individual's every day life. The importance of space in this daily ritual, and in particular the domestic space is paramount.

The strangers identity is defined by the oscillation of belonging to a group and being outside of one, it is therefore the domestic space that reinforces the strangers identity. As displacement, rupture and fragmentation become the dominant motifs for articulating the prevalent forms of experience in the modern world, it becomes vital to think again about how such experiences can be communicated.²⁵

The challenges associated with migrant communities are also reflected in the mental health of routine temporary shift workers, who are far from home and their families, but choose the lifestyle for economic or personal reasons. The existing anonymous architecture of camps only compound these feelings of isolation and identity fragmentation. An articulated architecture of variation and flexibility has the potential to celebrate the existence of a unique, shared experience.

A high degree of mobility and flexibility is expected from the individual today, and many are indeed willing to conform to these requirements. Yet humans cannot infinitely withstand stress. At the point when physical and psychological health are impaired, and the private life becomes strained and unsettled, the limits have been reached.²⁶



Jim

Carpenter from Cobden,
Ontario



Popinder

Hospitality from Calgary,
Alberta



Chad

Electrician from Bishop's
Falls, Nfld



Annicia

Electrician from
Kelowna, B.C.



Bowen

Rope access technician from
Sydney, Australia

25. Nikos Papastergiadis, *The Turbulence of Migration: Globalization, Deterritorialization and Hybridity*. (Cambridge: Polity Press, 2000), 12.

26. Rammler, "A Mighty Fortress," 218.

Individuals temporarily working in the region, 2014; photos by Ian Willms, "Workers' Lives in Northern Alberta," *The Globe and Mail* (Oct. 29, 2014)

This thesis proposes that the introduction of public space in temporary industry related environments, can have a positive contribution to the mental health of a camp inhabitants. By providing space for meeting fellow transient workers, and private space to make ones own, the architecture of temporary industry related inhabitation instead of attempting to mimic the comforts of 'home' can support an alternative transient community.



Conceptual image of public space in an industry-related transient community

CHAPTER 4: DESIGN

Shifting Site Types

The design proposal addresses the unique needs of the changing conditions of industry related inhabitation through a flexible method of settlement, that is applicable across scales and sites. The proposal develops a system of demountable, modular components that can be aggregated to create a variety of housing, and community space organizations. Three site types are selected from the region to test the design system. Existing sites for temporary camps are selected based on proximity to open pit mines and steam assisted extraction sites. Differences lie in their relationship to existing communities and industrial sites. The following images represent five site types identified, and analyzed in the region.

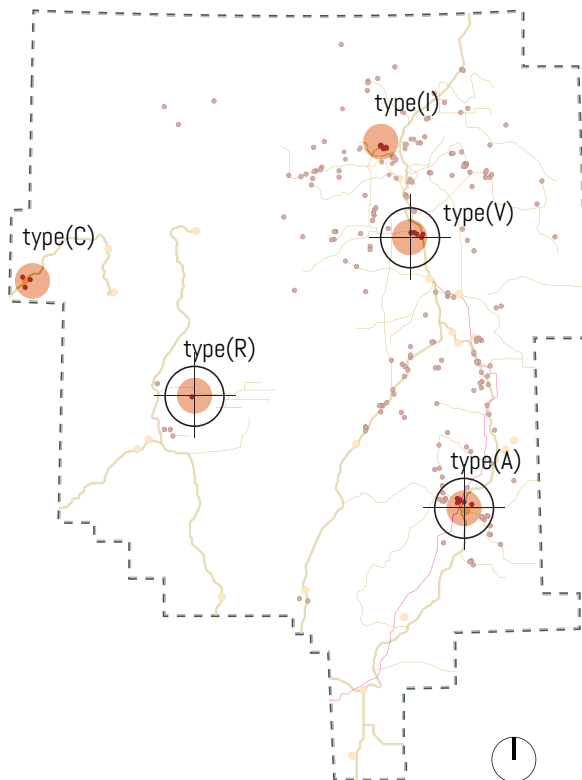

Location map of selected site types in the region, 2014; data from Government of Alberta, "CRISP AOSA"

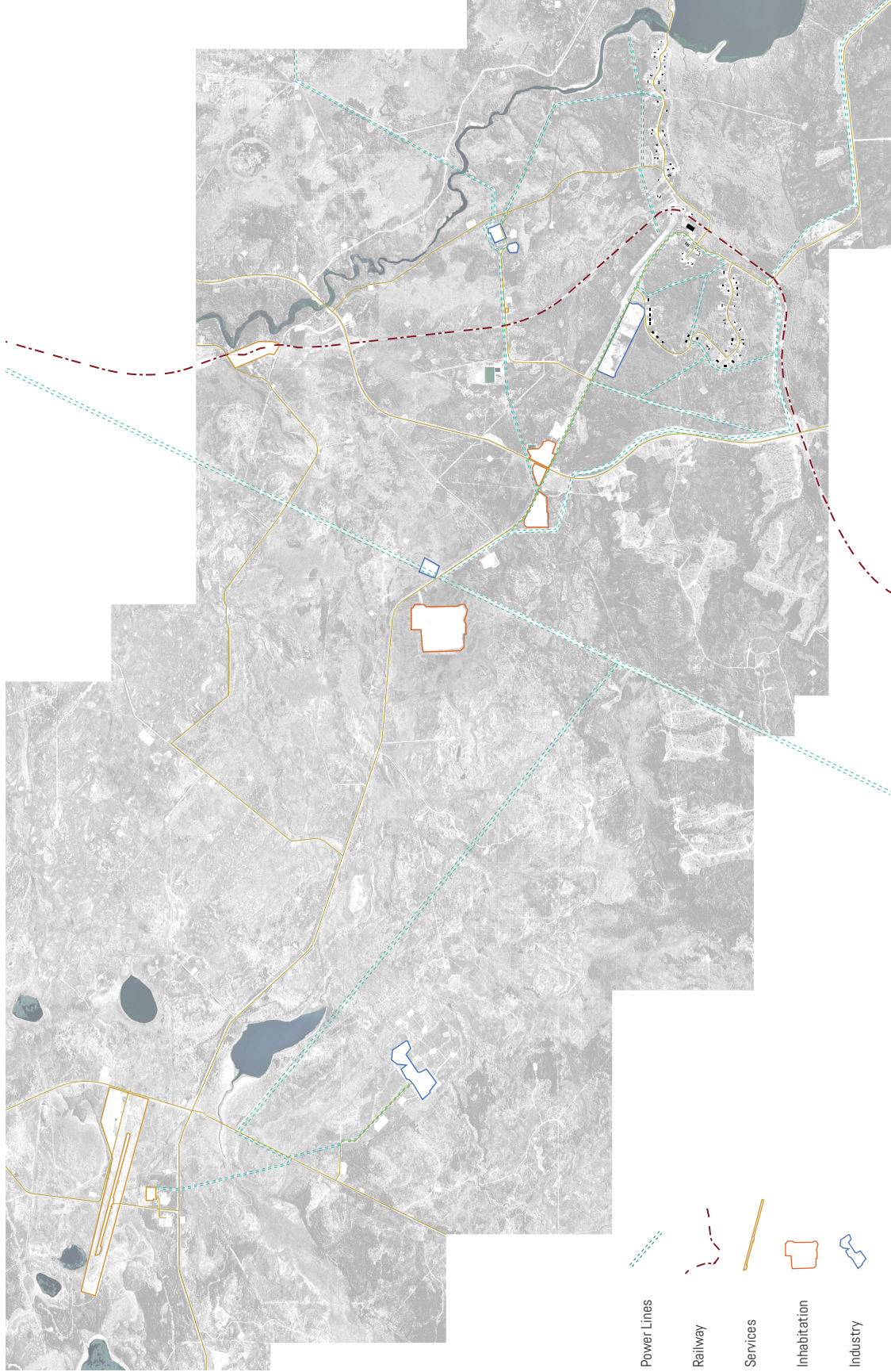

Type(A) inhabitation adjacent to an existing community (base map from Google 2013)



Type(R) remote inhabitation (base map from Google 2013)

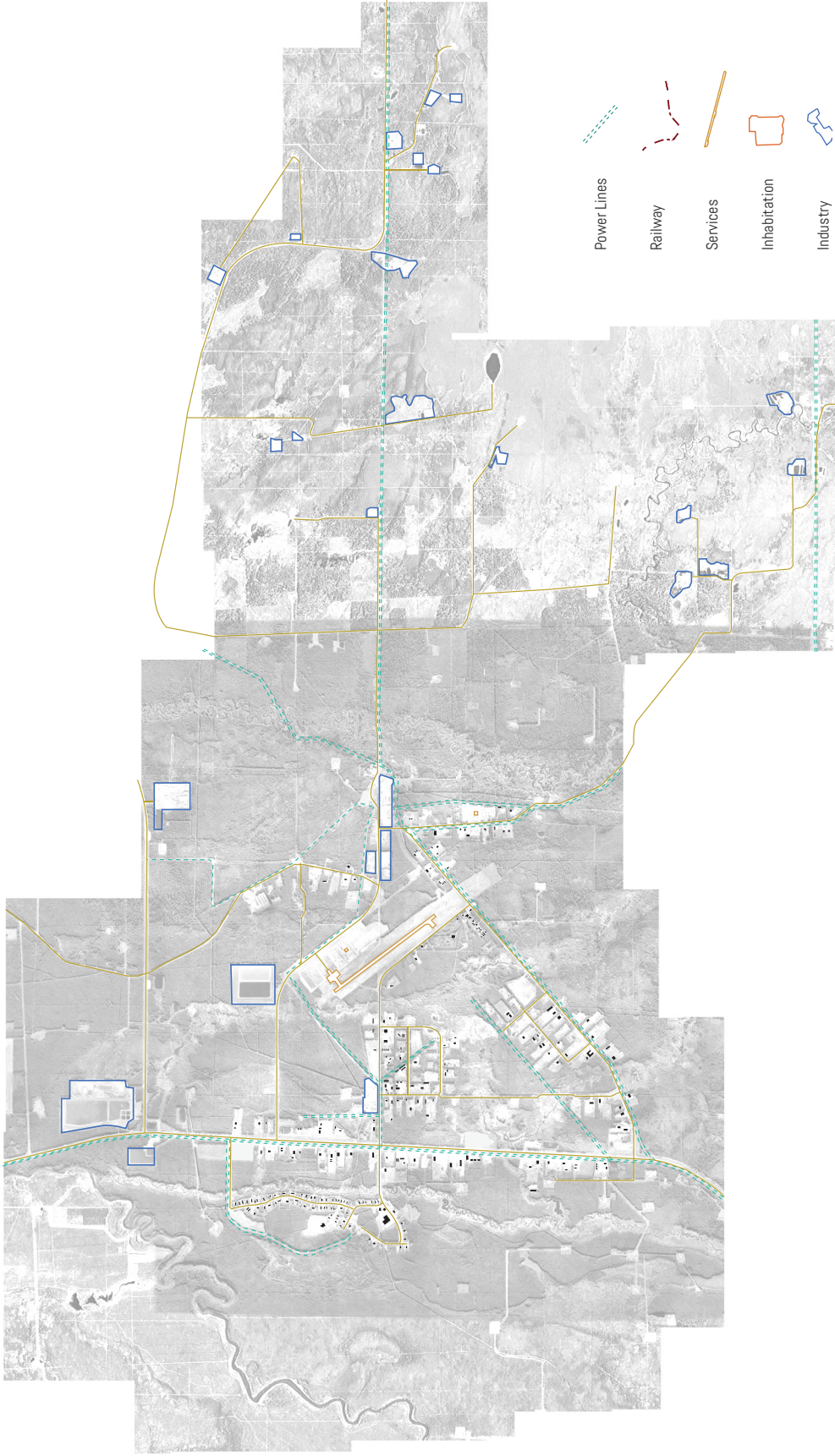

Type(C) temporary habitation within an established community (base map from Google 2013)

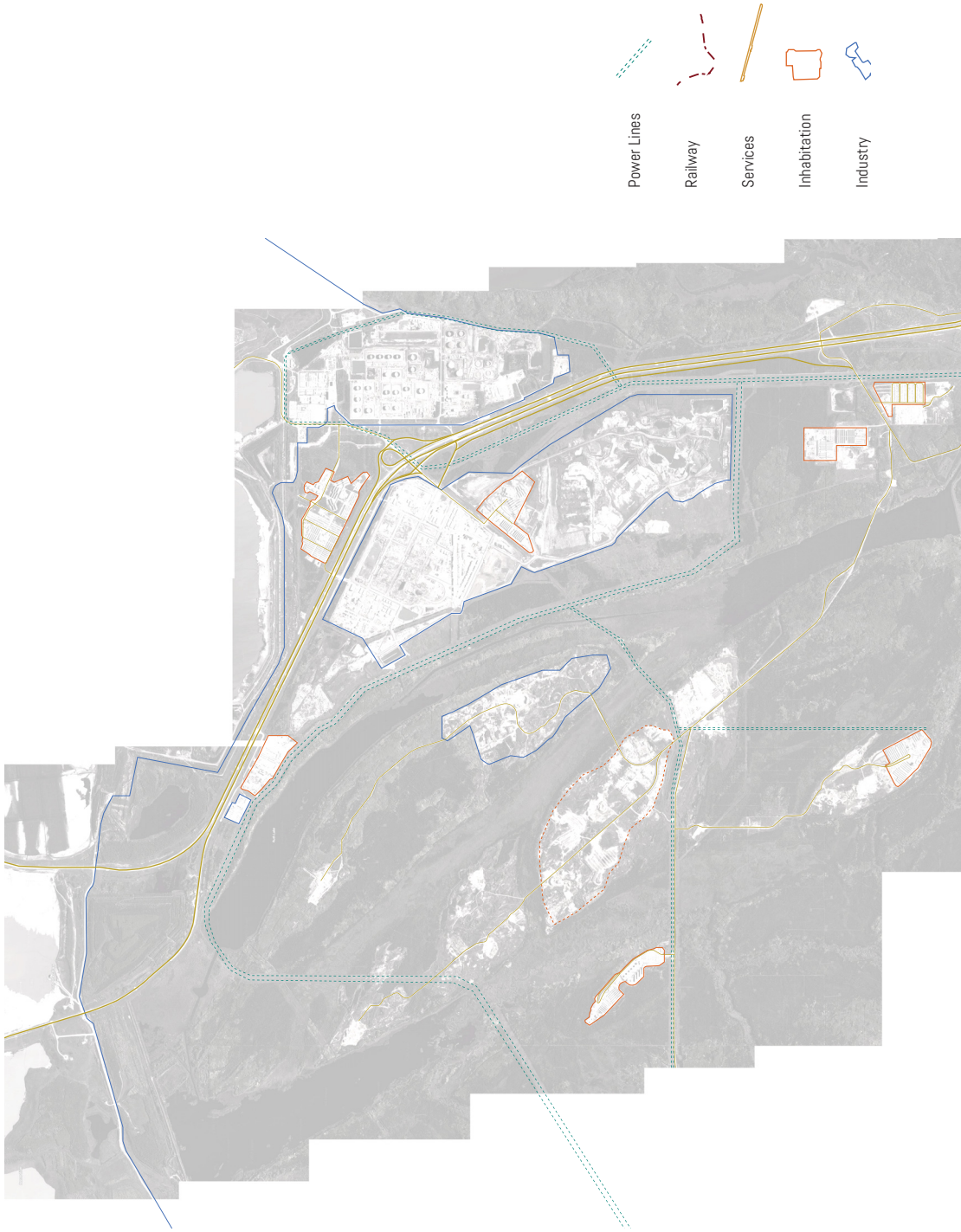

Type(V) village of clustered inhabitation adjacent to industrial site (base map from Google 2013)

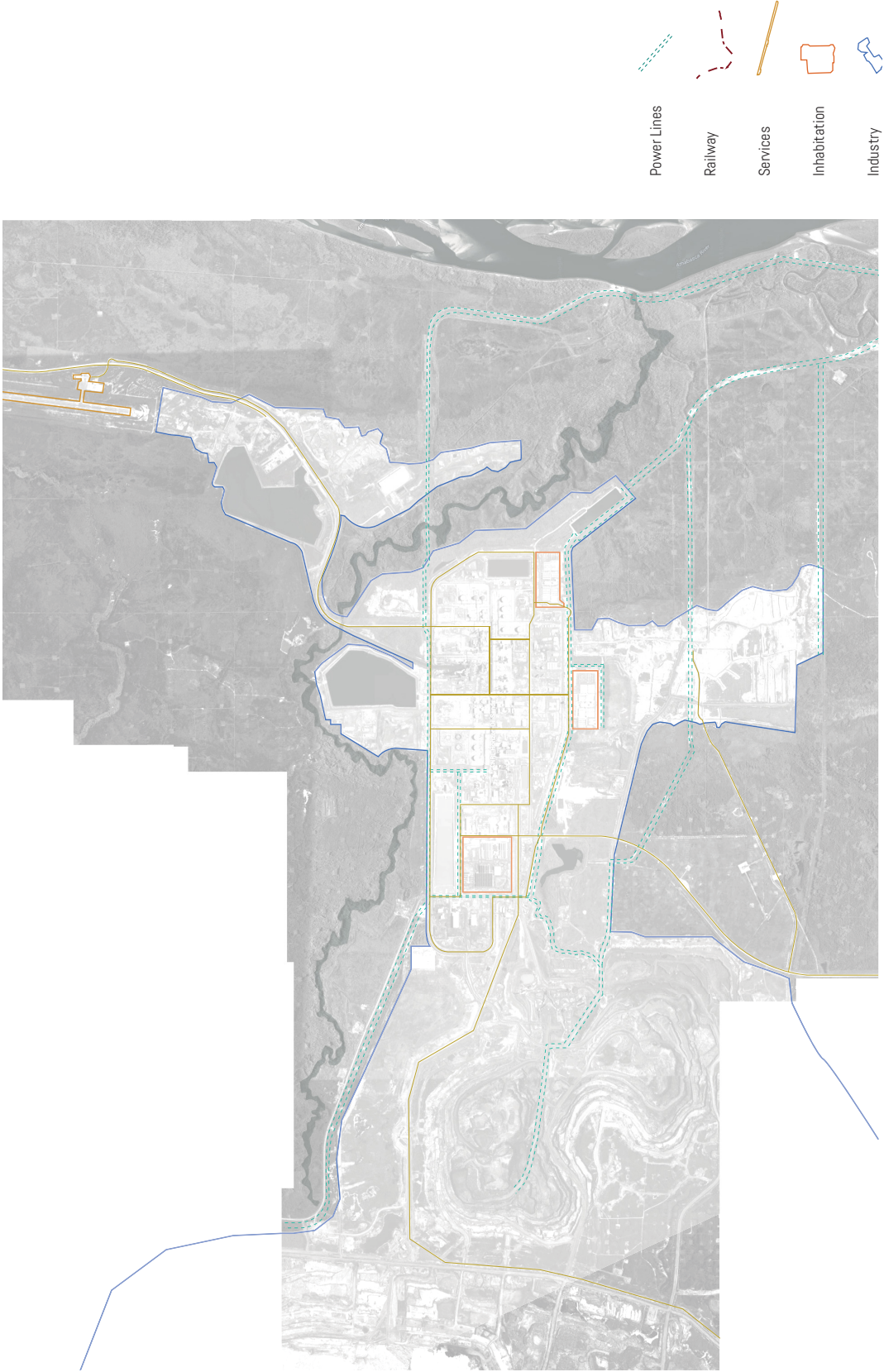

Type(I) inhabitation within industrial site, (base map from Google 2013)

Site Parameters and Organizational Principles

The approach to temporary inhabitation of site is rooted in the intention of making a place in a landscape that is often categorized as placeless, and unremarkable. Site selection for temporary inhabitation is solely based on proximity to open mines, extraction plants or other industry related factors. This thesis establishes a set of organizational principles that can be applied to any site, regardless of scale, that contribute to making a place for the individual in a temporary landscape. Of the five site types studied, three were chosen to test the design principles. The sites were selected based on their variance in scale and proximity to existing communities. The intention behind site selection is to develop a system that is applicable at a multitude of scales to meet the shifting employment demands of the industry.

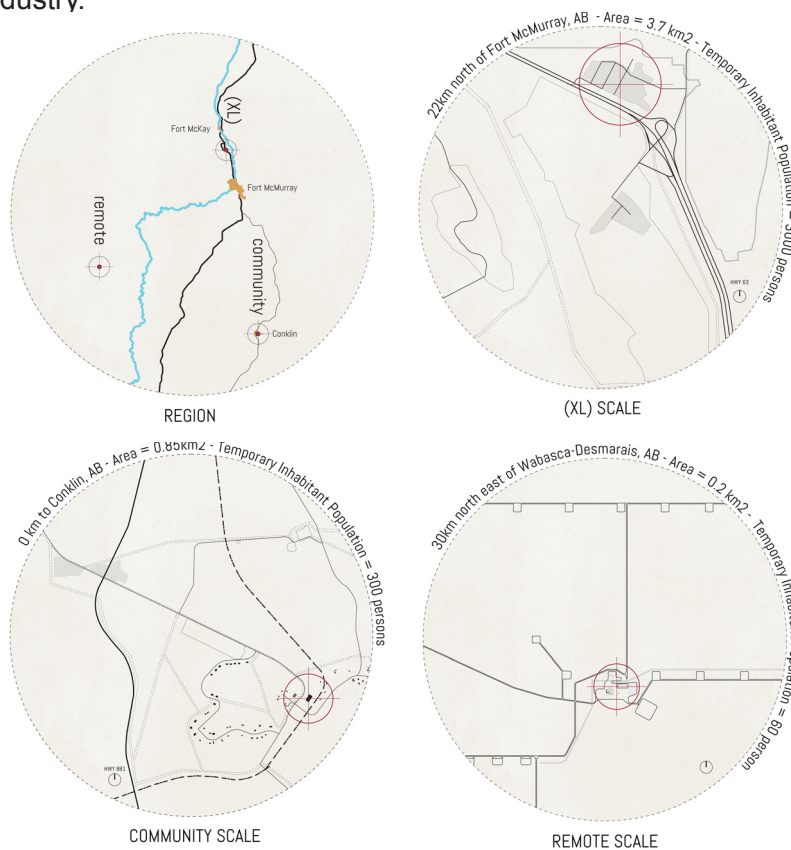

Selected sites for testing design proposal at an urban scale

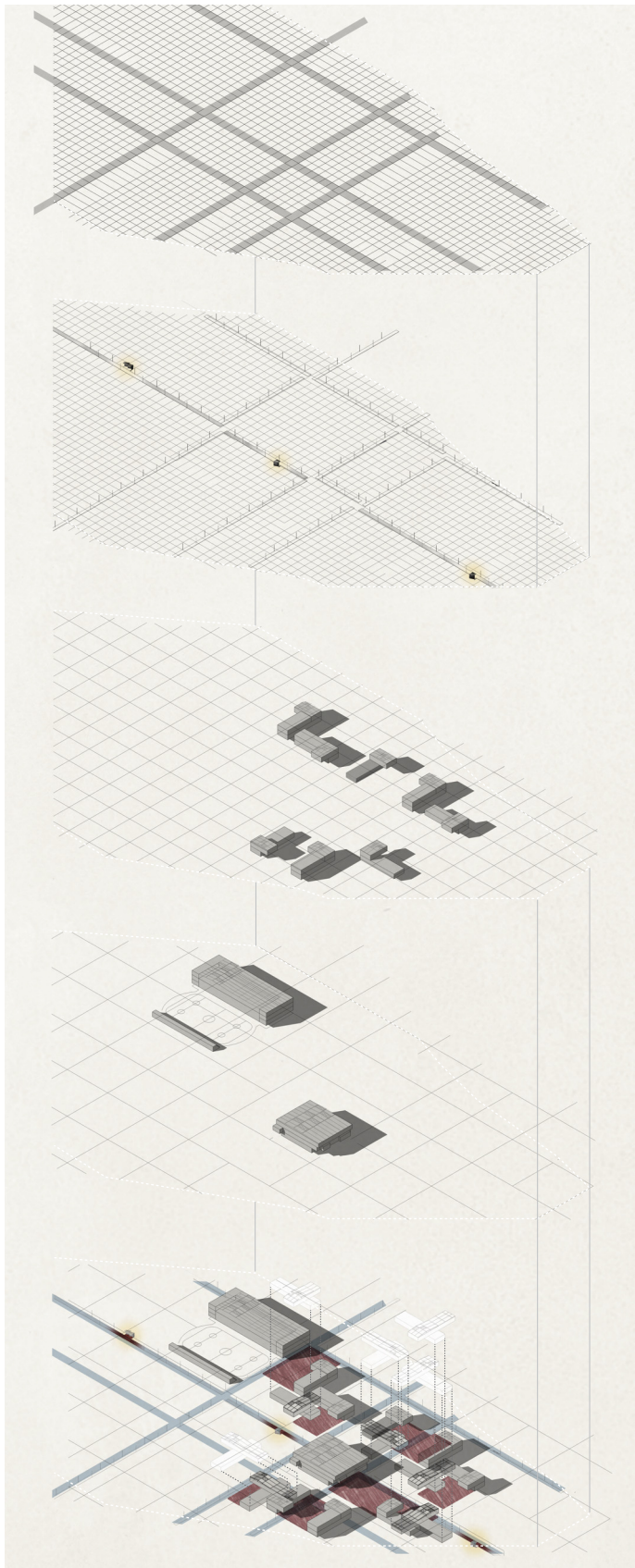

Each site is marked with a patterned grid of modules of 16'-24'-96', derived from the personal dwelling module built on a 8' structural grid.

A 16' grid is laid out first to house circulation pathways, forming 'pockets' to be occupied by dwelling and public modules.

The circulation elements are given a form of a raised platform for pedestrian circulation embedded with 'conduit' for crucial services to be delivered to housing modules.

Portions of the platform are extruded to create warming huts along the path to shelter inhabitants in transit to their dwellings.

A 24' grid marks where the housing modules will occupy the site. Placement of the modules considers location of entrances to other modules, creating outdoor community pockets.

The 96' grid organizes the placement of large public buildings. These buildings house a combination of individual dwelling units, basketball courts, ice rinks, community canteens, and laundry services for both transient and permanent communities to inhabit.

In a situation where a temporary industrial community requires more housing, a second layer of dwelling modules can be attached to previous modules.

This layered method allows for variation within outdoor and indoor spaces and appropriates the grid to create inhabitable temporary environments.

Site principles, diagram depicting layers of organization on each site



Detail of site principles, depicting layered approach to settlement

System for (Re)Assembly

The office of Kieran Timberlake promotes prefabrication as a method of building with the potential to streamline current construction processes without sacrificing quality and craft. By conceiving a building as a composition of few highly individualized elements rather than many small parts the designer is able to move from the part to the whole efficiently. By isolating elements of a building; wall, floor, structure as all inclusive elements the opportunity for craft lies in how the elements join to create an integrated whole.²⁷ This approach is adopted in this thesis as a means of recognizing the opportunity for temporary architecture to transcend the connotations of prefabrication as banal.

The design proposal of this thesis concentrates on the conception of the joint. A series of components, and their connections to one another are designed as inputs to a larger design strategy, that manifests at different site types. The tactile expression of the joint makes visible the demountable nature of the architecture, and elevates the notion of temporary inhabitation rather than masking or diminishing it.

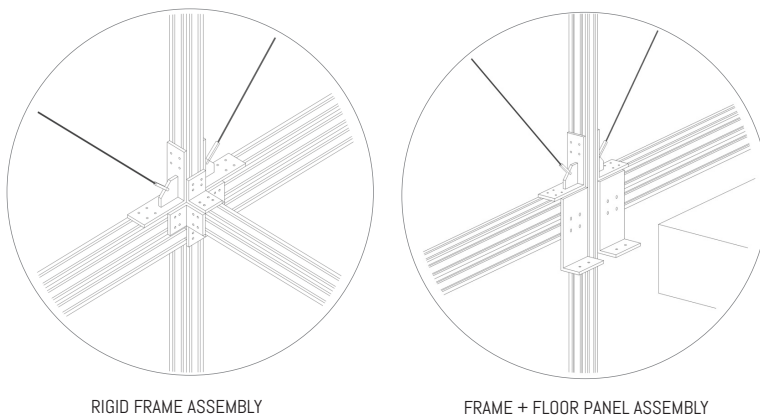

Details of joint connections, emphasizing the demountable nature of the structure.

27. Stephen Kieran and James Timberlake, *Loblolly House*. (New York: Princeton Architectural Press, 2008), 54.

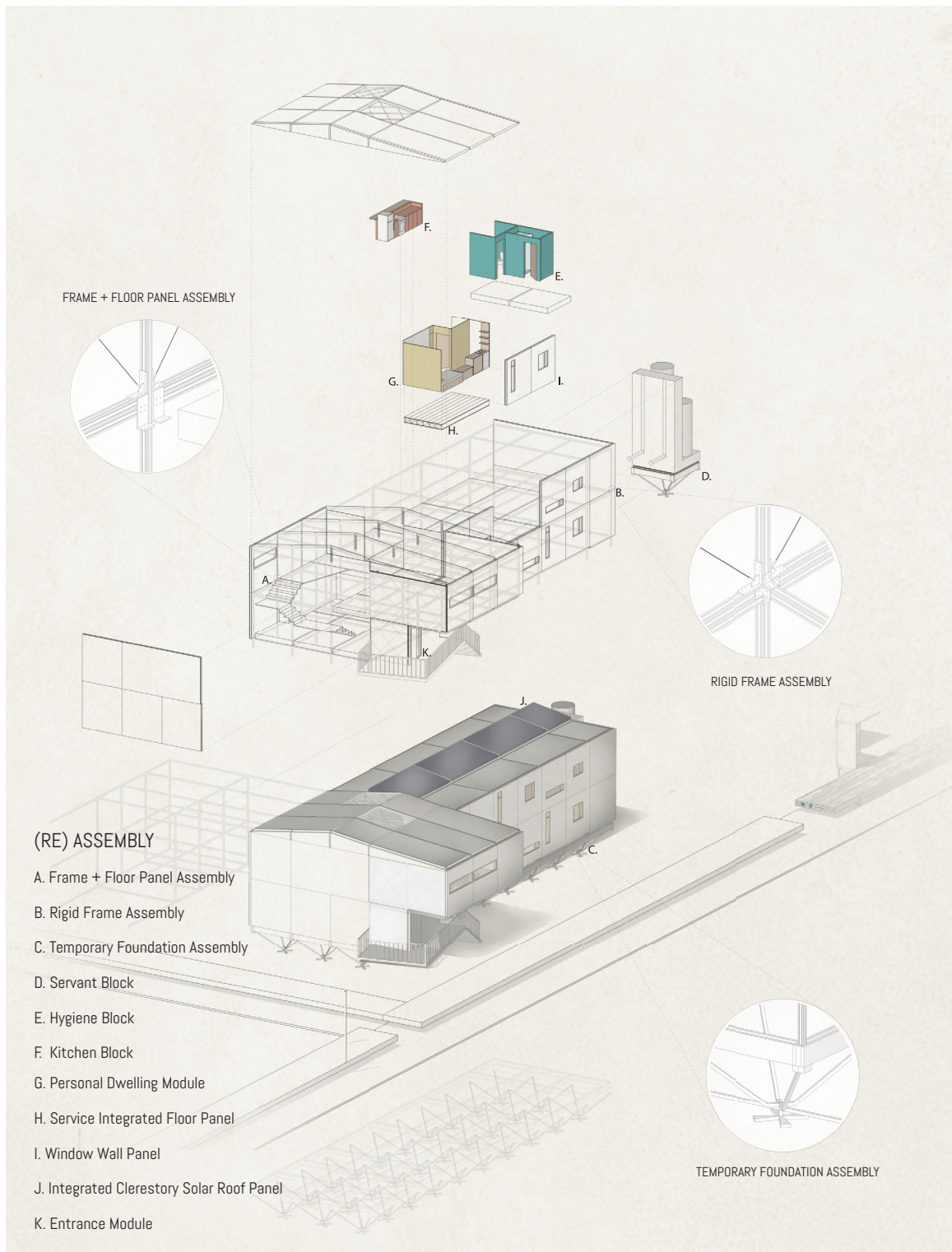

(Re) assembly axonometric, including component assemblies that manifest at all 3 site types

The structural system is composed of prefabricated aluminum extrusions. They form a rigid frame through a dry joint system, which can be assembled on site with limited skilled labor. Floor, roof, and wall panels are designed as self contained blocks that are pre fitted with openings for windows, pipes for services, structural members, and connection points. Vertical load is lightly distributed to the uneven ground through a space frame inspired foundation system. Bathrooms, kitchens, and the interior of individual dwelling units are manufactured as highly specialized blocks, that are inserted into the aluminum structural frame. Together these components formally address the temporary nature of industry related inhabitation, without losing touch with design of human scaled elements.

Public Modules

At the point of intersection of the stacked dwelling blocks lies the public space in each building. Regardless of where they intersect the main entrance and stair is lit from above, providing a space for inhabitants to socialize. The second level cantilever contains a lounge space and small kitchen. The point of intersection forms the connective tissue between private dorms, acting as the grounded, and constant element that any new arrival can make use of, and rely on. In this way the public space is a permanent element, in a temporary, and ephemeral landscape. By reconnecting the private realm with the public realm, program is dispersed, rather than isolated. Although configurations of private spaces, and their relationship to public space will change based on scale, the public space remains as the rooted element on site.

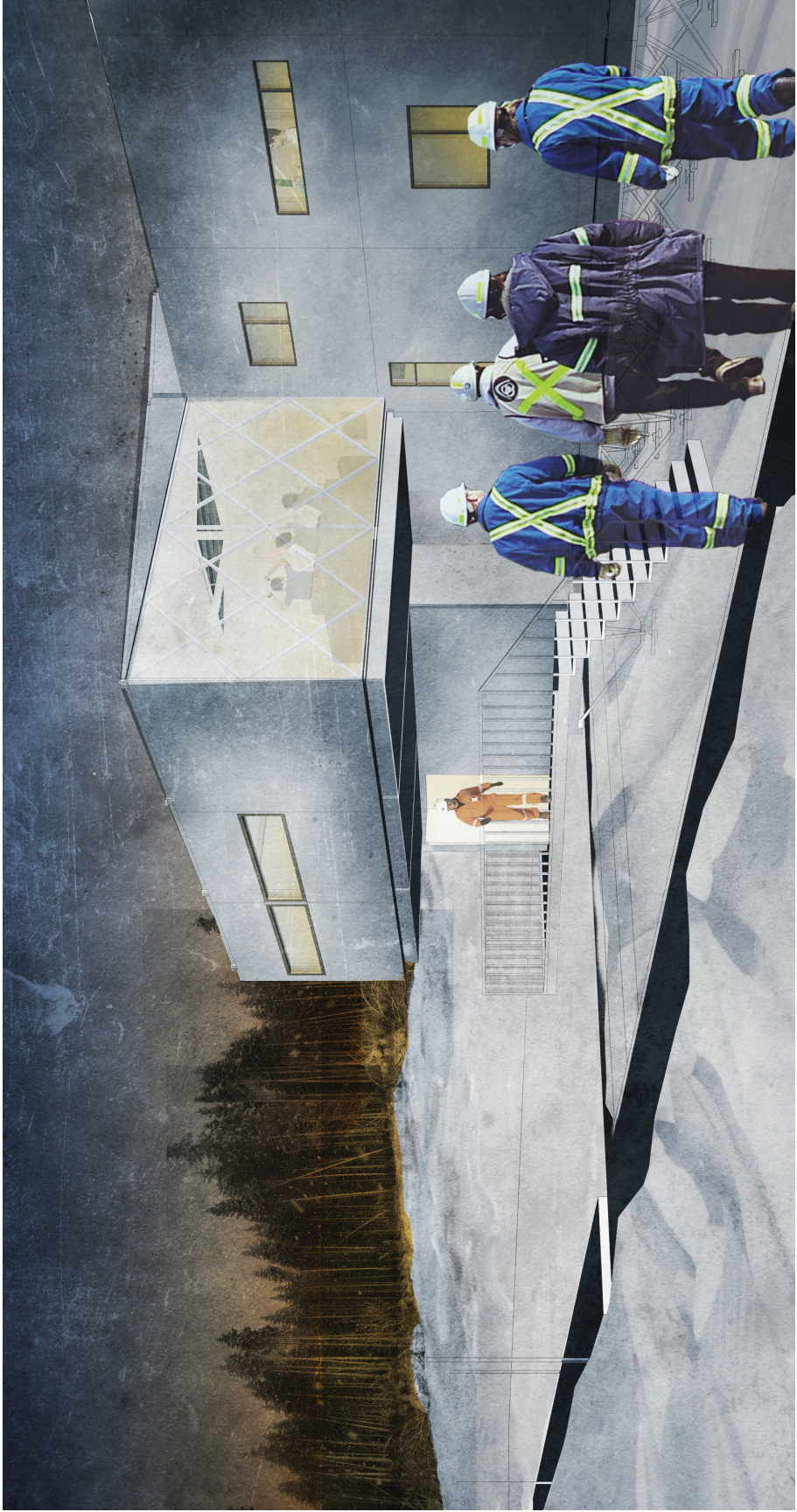

Start of shift / End of shift



Leaving for site

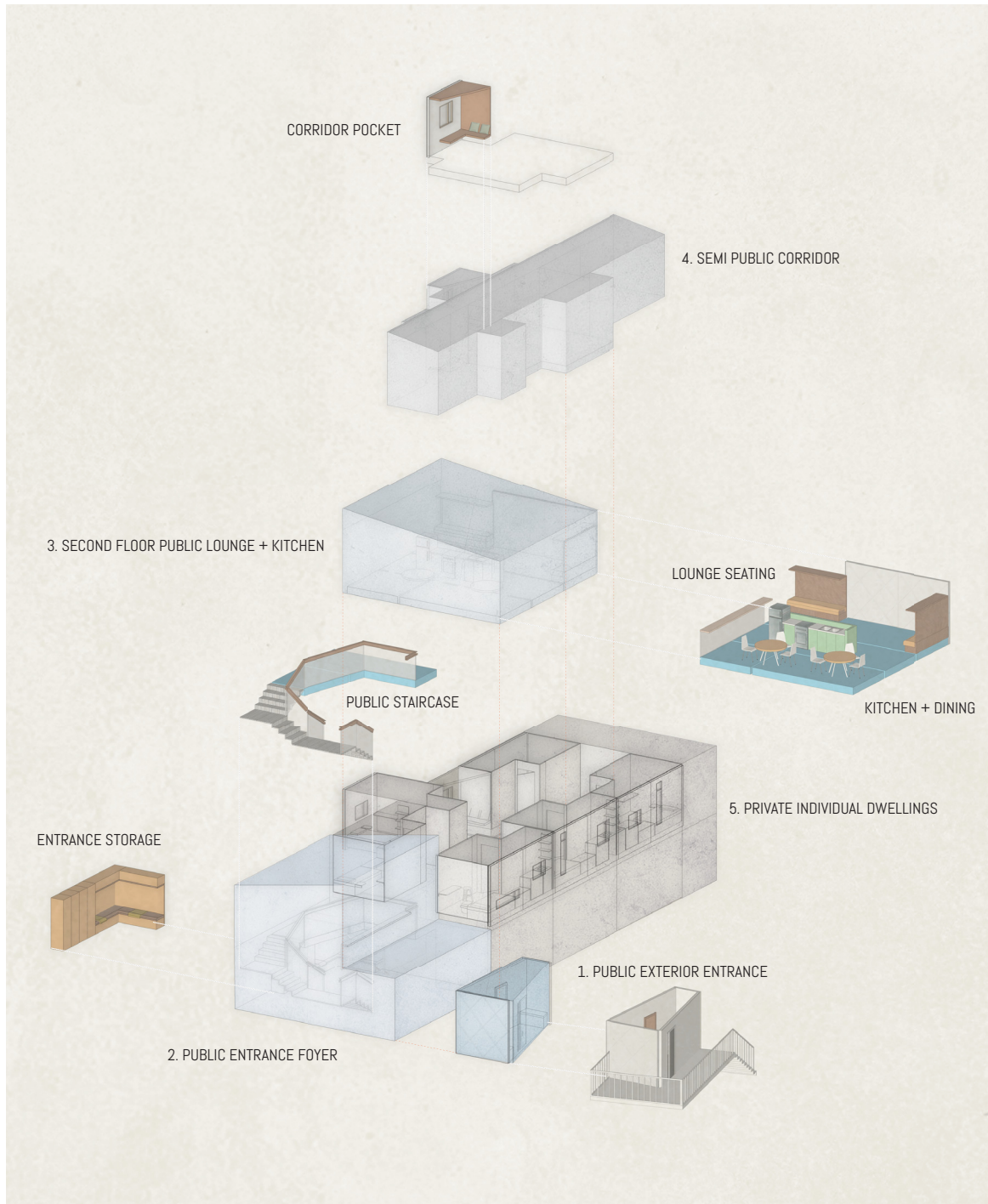

Inhabitation (re) assembly axonometric, including system for haptic experiences at key thresholds



Public corridor

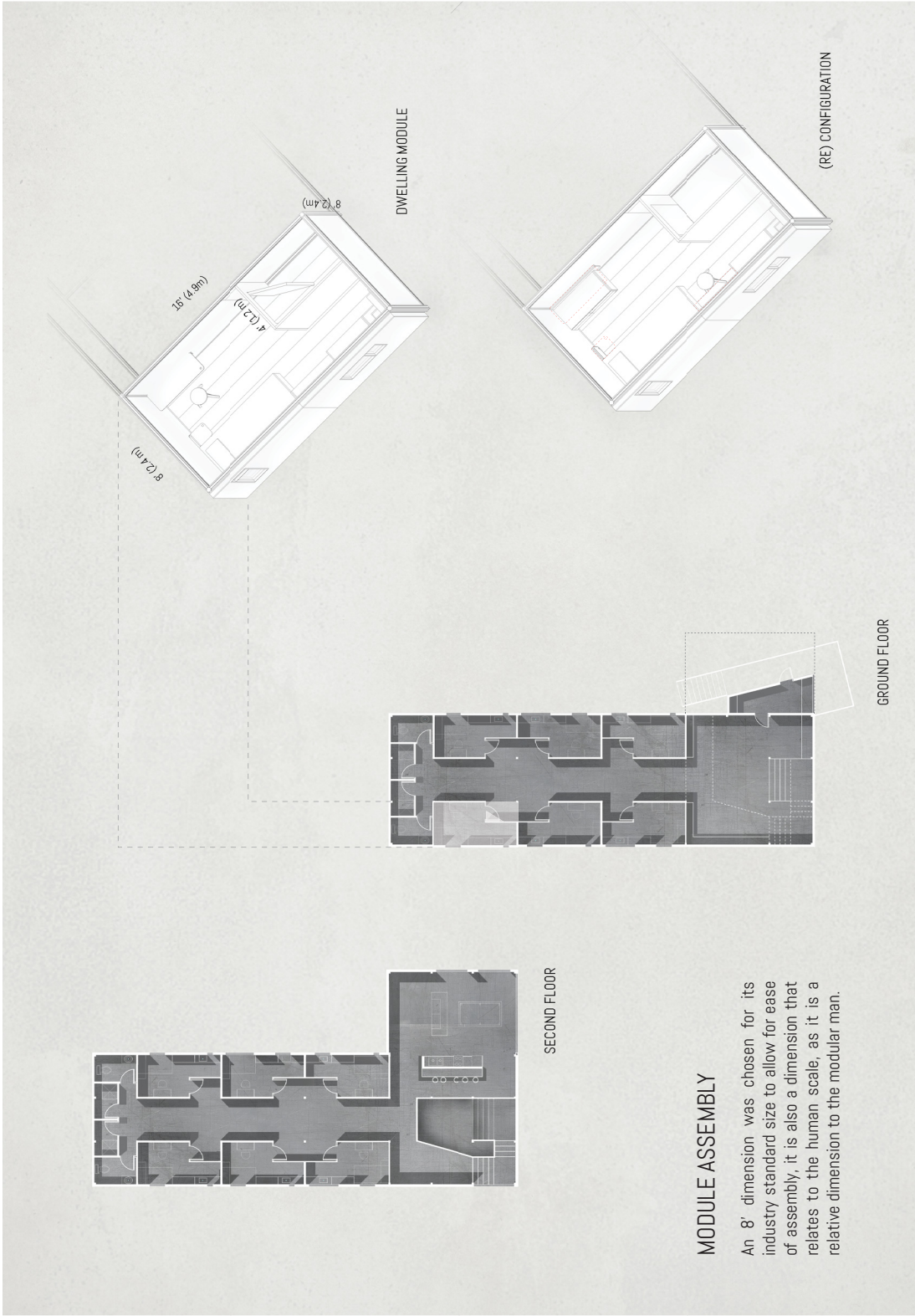

Plan of building for community of 10 and axonometric of individual rooms showing furniture configuration possibilities



End of day

Dwelling Modules

Every inhabitant is temporarily on site, the individual partakes in a temporal and unique monthly pilgrimage, where he or she embodies the site for short periods of time, and is continuously arriving, and departing. If a place of dwelling can physically express whether the space is vacant or occupied it responds to the unique shared experience of transient individuals. The celebration of arrival is achieved through the use of translucent polycarbonate wall panels that are insulated but provide a soft glow of light to the exterior, indicating to the new arrival that the unit is occupied.

For migrants, and transient workers 'home', rather than being a specific geographic location, is more and more about a set of personal activities, habits, and relationships, rather than an established continuum of habitation in the same location. Flexible furniture that allows the inhabitant to have a level of ownership over his or her space, could allow for a personal connection, or moments of reflection in ones private space. The design of the individual sleeping units considers unique preferences of each transient inhabitant, and includes a fold down desk, and bedside table as well as two windows providing a connection to the site at datum points relating to sitting height, and bed height.

(XL) Scale

The XL size camp is a significant site type to address with this design proposal, as it exists across the region in several locations adjacent to plant activity. In order to ensure that the system of (re)assembly is able to scale up in an appropriate manner, and consider the human dimension a camp of 3000 is organized into 5 districts. Each district

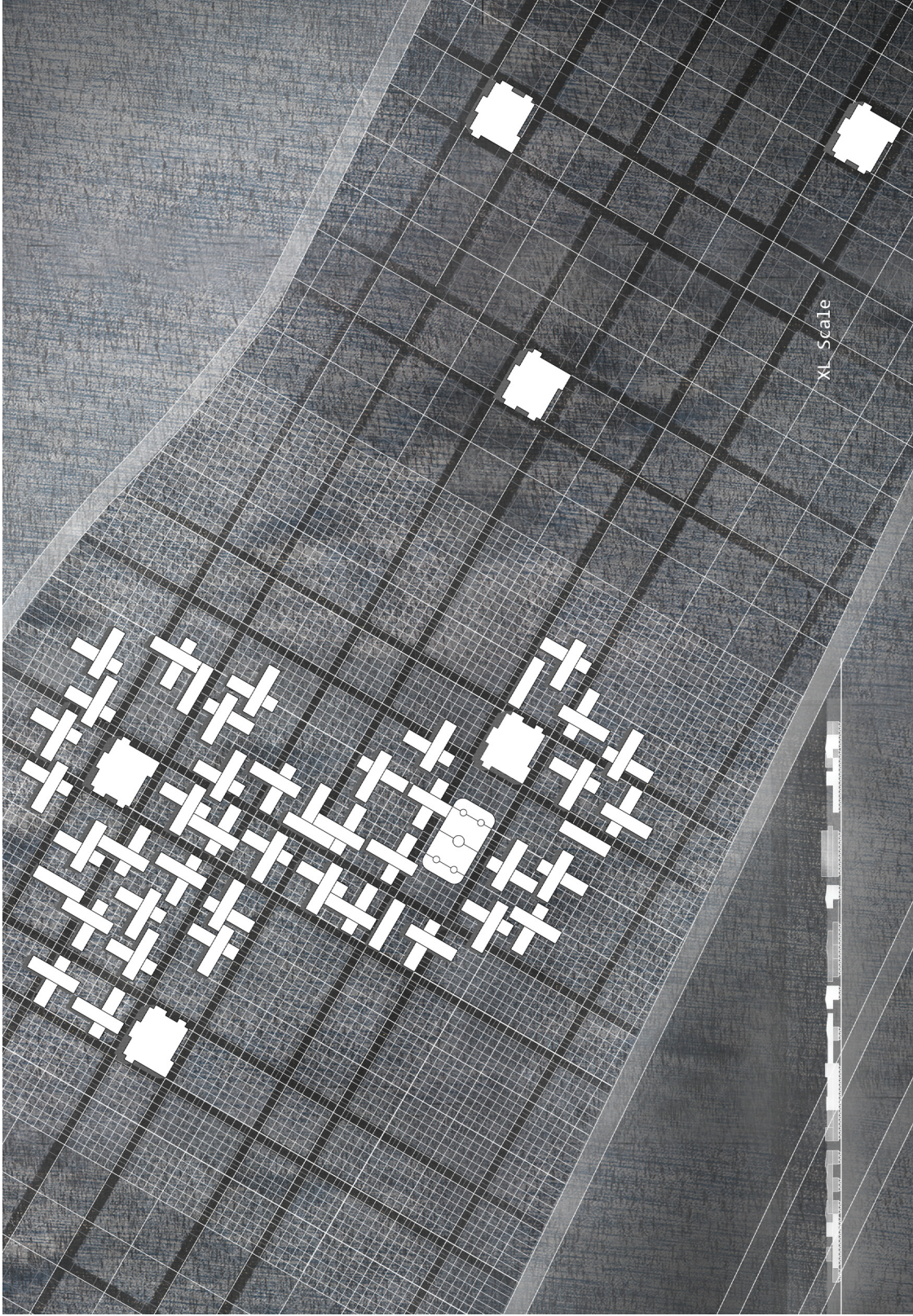

(XL) Camp site plan and section, including organizational layered grid pattern and urban foot print of a district

contains 3 aggregations of individual dwelling modules whose void space is occupied by a large public amenity; either a community kitchen, recreation space, or learning commons. In addition, a series of smaller aggregations of individual dwelling modules for a collective community of 10 persons, make up the demountable built fabric of the industry based moveable city. How these pieces work together to create opportunity for growth, and contraction on a large site requires a flexible organizational system. This thesis looks to structuralist concept of mat building to provide the possibility of flexibility.

The promise of mat building is that things happen in the voids. Out of a fundamentally regular system, a high degree of variation is achieved, through the activation of void spaces within the fixed fabric. This approach is used as a design tool for a large scale camp. A patterned grid is formed using modules of 16', 24' and 96'. This framework can either be built upon or not, it is this allowance that creates the opportunity for compositional flexibility at the urban scale. The 16' grid organizes the pedestrian and service vehicle pathways and also serves to connect districts to one another. The 24' grid demarcates the over all length of the buildings, and speaks to the dimension of the individual dorm modules. The 96' grid provides opportunities for activated void space as large public amenities. Together, this layered system allows for variation within outdoor and indoor spaces and appropriates the grid to create inhabitable temporary environments.

Existing Community Scale

At the scale of a rural community, the system for (re) assembly shrinks from the XL model, and focuses on the aggregation of individual dwelling modules to carve out a public amenity

at the centre. This space, be it a community kitchen or recreation space is accessible by both the transient, and permanent communities. By opening up a public amenity to both communities; the psychological wall that currently divides communities is replaced by a much needed facility for both parties, and provides an opportunity to meet, and get to know one another. This amenity can also remain long after the industry has moved to another phase, therefore having a positive effect on the established community.

Further to this, at the scale of the rural community the system for (re) assembly includes; demountable housing that is flexible enough to allow for family inhabitation, and welcomes the possibility for long term inhabitation for those who after spending so much time in the region, begin to call it home.

Remote Scale

At the scale of a small camp for 60 workers, whose remote location diminishes the opportunity to draw ties to existing communities, the system of (Re) Assembly shifts to create an insular community for the workers on site. Individual dwelling units are aggregated to carve out amenity space at the centre, that houses recreation and food preparation. The integration of all components in one building assists in the delivery of essential services to an isolated site. Even at the smallest site scale, collective space is conceived as the primary element on site.

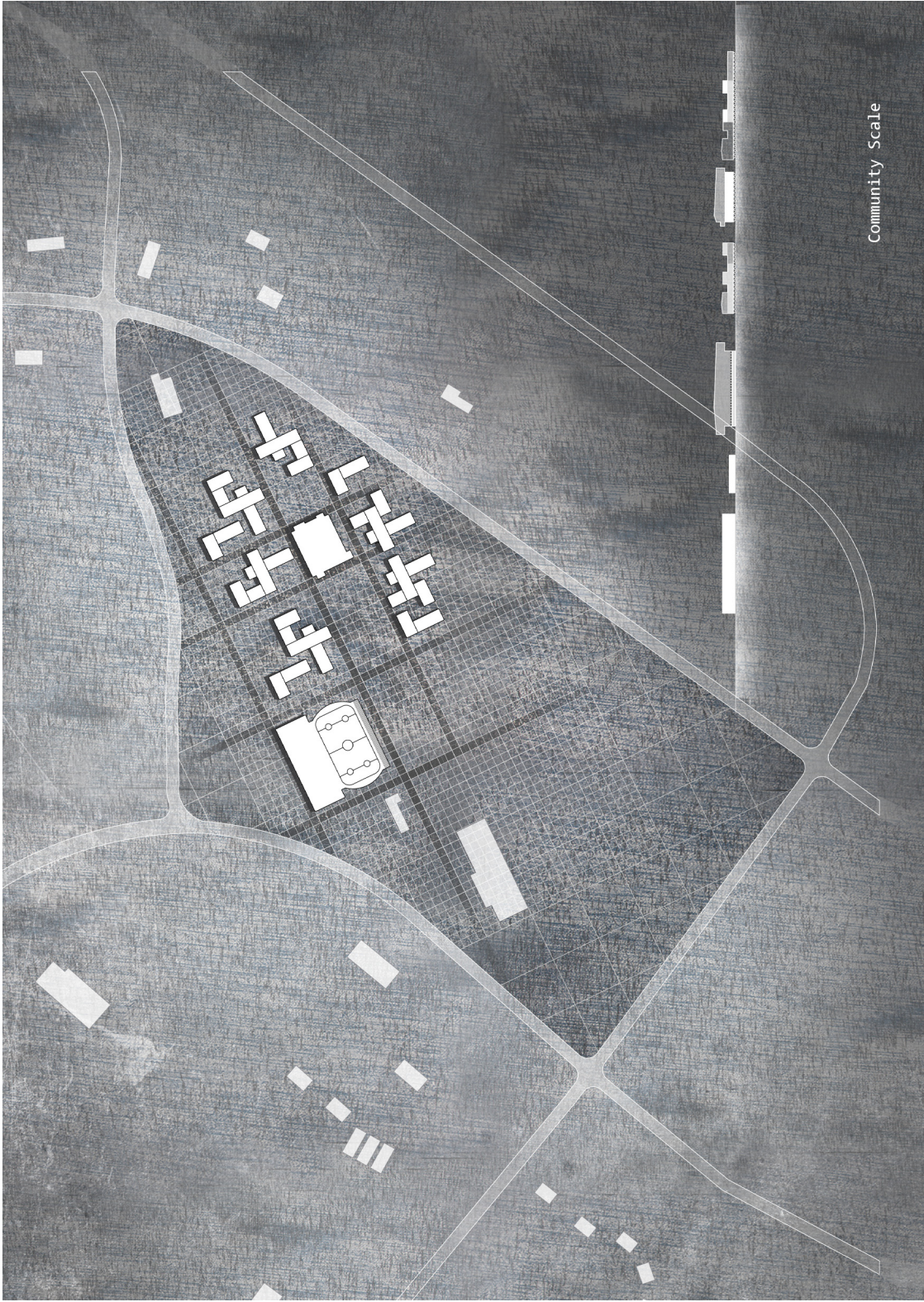

Hamlet of Conklin site plan and section, including organizational layered grid pattern



Community building: Saturday morning



Remote Scale

Remote camp site plan and section, including organizational layered grid pattern

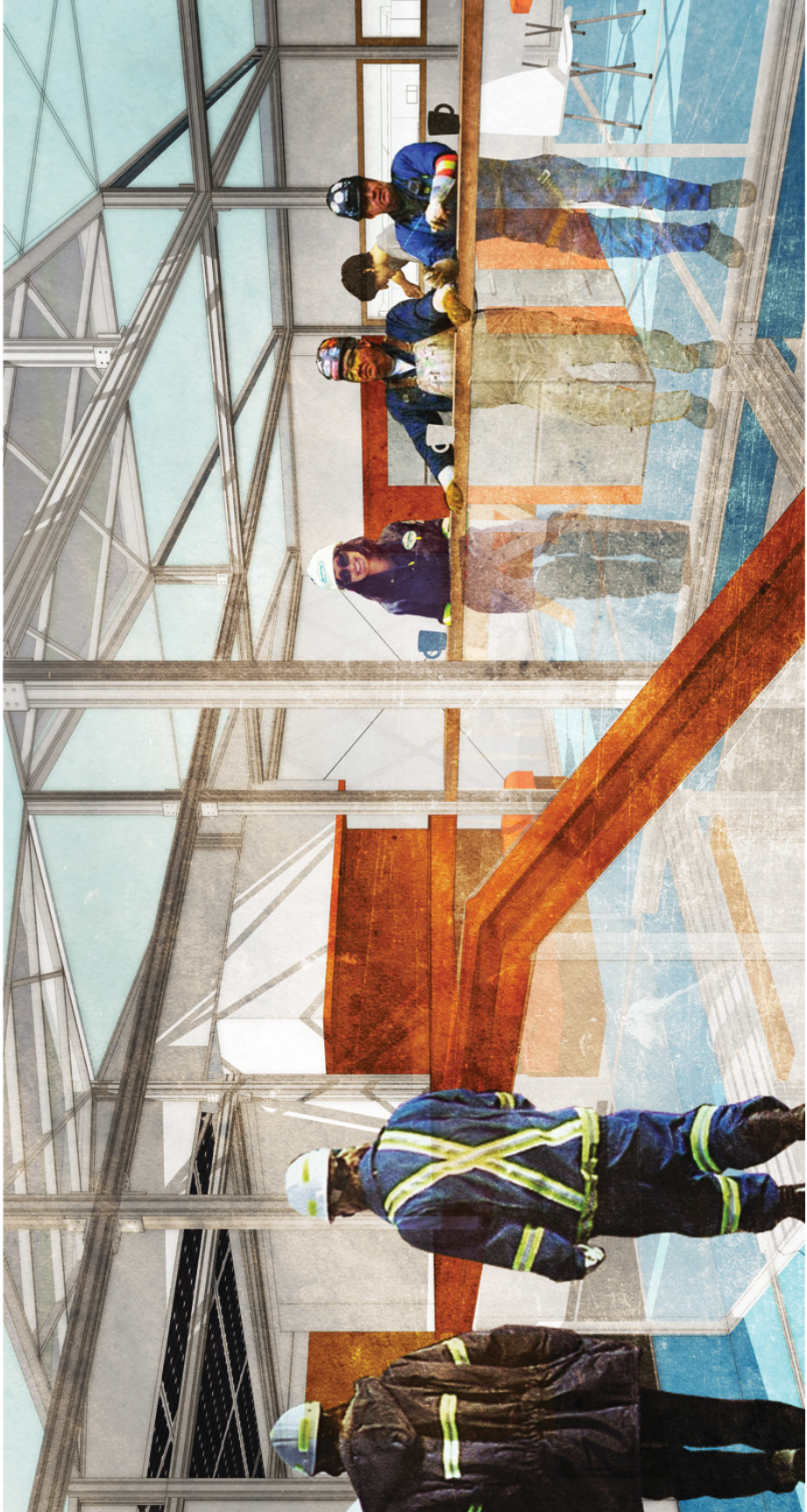

Morning coffee

CHAPTER 5: CONCLUSION

The unchecked approach to the Alberta oil sands industry is a model that is in need of regulation. Not only in matters of environmental protection but in parameters regarding the lives of the workers who build roads, operate plants and provide essential services to the region.

As a student of architecture, my approach to addressing the seemingly unchecked and capital driven oil and gas industry is to focus on re humanizing the day to day experience of transient workers. I am addressing the very real housing needs in the region and proposing that an alternative is possible, that the architecture of temporary inhabitation can respond to the needs of the industry, all without losing sight of the human scale.

By re envisioning the possibilities for temporary industry related inhabitation, the architecture in the region can have a positive effect on its users by embracing the uniqueness of their lifestyle. The introduction of a varied and comfortable spatial experience has the potential to allow its users to dwell in a way the individual deems appropriate rather than prescribing a rigid form of settlement.

This proposal for temporary, flexible and movable housing can be applied to other regions partaking in resource development, as well as meeting housing needs for refugee camps and remote localities where urban infrastructure may be scarce.

BIBLIOGRAPHY

- Anderson, Mark, and Peter Anderson. *Prefab Prototypes: Site Specific Design for Off site Construction*. New York: Princeton Architectural Press, 2007.
- Black Diamond Limited. Photograph of a Typical Temporary Camp, Alberta. 2014.
- Calabuig, Deborah Domingo, Raul Castellanos Gomez, and Ana Abalos Ramos. "The Strategies of Mat Building." *The Architectural Review*, August 13, 2013. <http://www.architectural-review.com/essays/the-strategies-of-mat-building/8651102.article>.
- Cryderman, Kelly. "The Dispute the Entire Oil Industry is Watching." *The Globe and Mail*, Dec. 14, 2013.
- Doran, Kelly. "Operational alternatives: (Re-)configuring the Landscape of Alberta's Athabasca Oil Sands." In *Sustain and Develop*, edited by Joshua Bolchover and Jonathan D. Solomon, 40-44. New York: Princeton Architectural Press, 2009.
- Doran, Kelly. "Operational Alternatives: Speculative Architecture for Industrialized Landscapes." Master of Architecture Thesis, University of Toronto, 2006.
- Google. Map of Established Community Populations and Locations. Accessed Oct. 9, 2014. <http://maps.google.ca>.
- Google. Map of Estimated Population and Locations of Temporary Camps. Accessed Oct. 9, 2014. <http://maps.google.ca>.
- Government of Alberta. "CRISP AOSA: Comprehensive Regional Infrastructure Sustainability Plan for the Athabasca Oil Sands Area." Last modified April 2011. <http://www.energy.alberta.ca/Initiatives/3240.asp>.
- Hailey, Charlie. *Camps: A Guide to 21st Century Space*. Cambridge: MIT Press, 2009.
- Kieran, Stephen, and James Timberlake. *Loblolly House*. New York: Princeton Architectural Press, 2008.
- Koolhaas, Rem, and Hans Ulrich Obrist. *Project Japan: Metabolism Talks*. London : Taschen, 2011.
- Kronenburg, Robert. *Houses in Motion: The Genesis, History, and Development of the Portable Building*. 2nd ed. West Sussex: Wiley-Academy, 2002.
- Kronenburg, Robert. "Modern Architecture and the Flexible Dwelling." In *Living in Motion: Design and architecture for flexible dwelling*, edited by Mathias Schwartz-Clauss et al, 19-76. Ditzingen: Vitra Design, 2002.
- Kronenburg, Robert, and Filiz Klassen. *Transportable Environments 3*. New York: Taylor & Francis, 2006.

- Lapuerta, Jose Maria de. *Collective Housing: A Manual*. Barcelona: Actar, 2007.
- Lewis, Jeff. "Fort McMurray cracks under oil boom's strain." *The Globe and Mail*, Oct. 28, 2014.
- Lewis, Jeff, and Jeffrey Jones. "Under Pressure in the Alberta Oil Patch." *The Globe and Mail*, Feb. 20, 2015.
- McCarthy, Shawn. "Why the Oil Sands matter to every Canadian." *The Globe and Mail*, Oct. 28, 2014.
- Papastergiadis, Nikos. *The Turbulence of Migration: Globalization, Deterritorialization and Hybridity*. Cambridge: Polity Press, 2000.
- Principia Legionis. "Army Camps." Last modified November 16, 2014. <http://www.principialegionis.org/armycamps.html>.
- Rammler, Stephan. "A Mighty Fortress...On the Sociology of Flexible Dwelling." In *Living in Motion: Design and architecture for flexible dwelling*, edited by Mathias Schwartz-Clauss et al, 199-219. Ditzingen: Vitra Design, 2002.
- Regional Municipality of Wood Buffalo. "Wood Buffalo Municipal Census 2012." Last modified October 2012. <http://www.woodbuffalo.ab.ca/Assets/Corporate/Census+Reports/Census+reports+Part+1.pdf>.
- Richardson, A. "The Orientation Of Roman Camps And Forts." *Oxford Journal of Archaeology* 24, no. 4 (2009): 415-426.
- Schalk, Meike. "The Architecture of Metabolism: Inventing a Culture of Resilience." *Arts* 3, no. 2 (2014): 279-297.
- Schwartz-Clauss, Mathias. "Dwelling on Living in Motion - An Introduction." In *Living in Motion: Design and architecture for flexible dwelling*, edited by Mathias Schwartz-Clauss and Alexander von Vegesack, 12-17. Ditzingen: Vitra Design, 2002.
- Schwartz-Clauss, Mathias, and Alexander von Vegesack. *Living in Motion: Design and architecture for flexible dwelling*. Ditzingen: Vitra Design, 2002.
- "Scraping For Oil: The Vast Reconfigured Landscape Of Alberta's Athabasca Oil Sands Is Largely Hidden From View, Remaining A Mystery To Designers." *Canadian Architect*. Last Modified January 1, 2009. <http://www.canadianarchitect.com/news/scraping-for-oil/1000228228/?&er=NA>.
- Valena, Thomas F., Tom Avermaete, and George Vrachliotis. *Structuralism Reloaded: Rule-based Design in Architecture and Urbanism*. Stuttgart: Edition A. Menges, 2011.
- Willms, Ian. "A day in Fort McMurray: Upgraded trucks, million dollar homes and bitumen paintings." *The Globe and Mail*, Oct. 29, 2014.
- Willms, Ian. "Workers' Lives in Northern Alberta, in three simple words." *The Globe and Mail*, Oct. 29, 2014.