

CATALYST
A NEW PUBLIC ARCHITECTURE FOR COMMUNITY RESILIENCY

by

Ben Scott Weiss

Submitted in partial fulfilment of the requirements
for the degree of Master of Architecture

at

Dalhousie University
Halifax, Nova Scotia
June 2016

© Copyright by Ben Scott Weiss, 2016

CONTENTS

ABSTRACT	v
ACKNOWLEDGEMENTS.....	vi
Chapter 1: Introduction.....	1
Chapter 2: Conclusion.....	15
Appendix A: The Barn That Raised Me	59
Section 1: Observation and Theory	61
A Landscape in Time_Community	65
The Generational Farm_Live	71
Value Add Process_Work	79
The Rural Experience_Play	89
Agro-Architecture_Design.....	99
Section 2: Architecture and Aldo Van Eyck.....	119
Reciprocity of the Antonym	125
Aesthetics of Number	133
City as Playground.....	137
The Peripheral Experience	145
Section 3: Radical Rationalization	157
Actor-Network Theory	165
Architecture without Architects.....	169
Shiny Pebbles and Large Ripples.....	179
Community Resiliency	187
Schematic Sustainability.....	197
Energy Economics.....	207
Appendix B: The Barn I'd Raise	215
Section 1: Rural Reclamation	217
Rural Landscape_Environment	223
Rural Networks_Economic	237
Rural Systems_Social.....	247
Retting_Cultural	253
Section 2: The Seed Building	257

Food_Kitchen Greenhouse	261
Energy_RE-Tower	265
Experience_Barn	269
Sensation_Smokehouse.....	273
Resilience_Granary	275
Design_Consumer Tube.....	277
Section 3: Agro-Architecture.....	281
The Bungalow Farmhouse.....	283
The Saltbox Farmhouse	287
The Stacked Farmhouse	291
Section 4: The Harvest	295
Live_The Configured Farmhouse	297
Work_Decortication Facility	305
Play_The Community Hall	321
Conclusion	331
Bibliography.....	338

ABSTRACT

Agriculture has an intimate connection to human material culture, bolstered by the symbolic image of the generational farmer. The cultural identity of the farmer is understood as caretaker, entrepreneur, community provider and naturalist, and beyond all this, the provider of the quintessential social experience - food. At present, the traditional family farm model is challenged by the industrial agricultural process to compete in global networks at the expense of local ecological capacity.

The implications of Alberta's resource wealth has made the region a standing candidate for industrialization and has resulted in a building culture that places economics and utility above materiality, tectonics and ecology. Although these conditions are province wide, I will use the rural hamlet of Warwick, Alberta, as site and case study to illustrate the existing prairie landscape in a critical stage of metamorphosis.

This research is intended to develop an architectural design process wherein the architect actively seeks rural communities in need of social, cultural, economic and environmental revitalization. A new public architecture that seeks to directly engage consumer identity in the rural landscape. By partnering with entrepreneurial producers seeking to develop rural markets of production, the architecture can facilitate a passive learning environment which transcribes the farms product into consumer experience. The farm is inherently social and becomes the catalyst for resilient community growth.

ACKNOWLEDGEMENTS

The individual's identity is a result of the family, friends and colleagues who grow their opinion, and in turn, the ability of the individual to change the world. I would like to give special thanks to Fraser Plaxton, Brent Schmidt, and Damon Hayes Couture for their assistance in this thesis project.

Chapter 1: Introduction

Never cease to identify whatever you construct with the people you are constructing it for - for those it will accommodate. Identify a building with that same building entered - hence with those it shelters, and define space - each space built - simply as the appreciation of it.

Architecture can do no more, nor should it ever do less, than accommodate people well; assist their homecoming.

-Aldo Van Eyck¹

1. Van Eyck, Vincent, and Strauven, eds., Writings, 53.

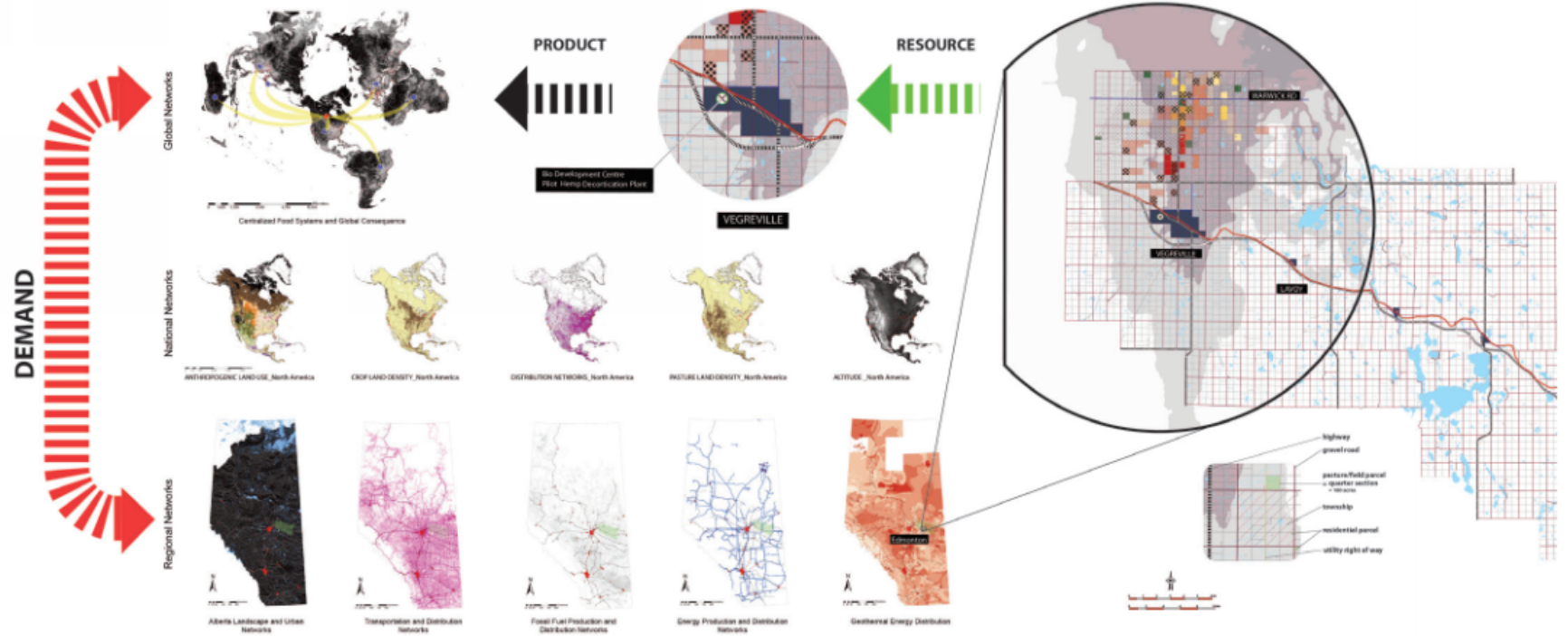

Global Systems of Food Production and the Generational Family Farm.
 A perspective of the mechanized rural landscape and inherent cycles of degradation.

Maps throughout this publication were created using ArcGIS® software by Esri. ArcGIS® and ArcMap™ are the intellectual property of Esri and are used herein under the license. Copyright© Esri. All rights reserved. For more information about Esri® software, please visit www.esri.com.

Maps throughout this publication were created using free GIS data provided by Natural Resources Canada and the Government of Canada. Last modified July 12, 2016. <http://www.nrcan.gc.ca/earth-sciences/geography/topographic-information/free-data-geogratis/download-directory-documentation/17215>

The notion of homecoming is inherently subjective, a result of the individuals conception of what “home” is. Given the enormity of the world and the unique socio-cultural development of its inhabitants, there is no definitive consensus of homecoming, yet we may share similar conceptions of what homecoming may be. What becomes evident are the patterns of live and work that may reveal the individuals experience of homecoming within landscape, and a notion for architectural response. The virtue of the individual is a uniquely defined interpretation of the landscape they experience, and is an interpretation which may simultaneously engage the past, present and future experience. It is important to remember that the individual bears a simultaneous nature of being consumer and producer as they inform their Live/Work/Play lifestyles.

My own notion of homecoming is the family farm set in Alberta’s prairie landscape. A notion shared by the families and neighbors of Warwick, a prairie town remnant and surviving rural community. More than a farm in the country, the daily rituals and freedoms of the agricultural process transcribe a producer’s playground, and reveal the farmers manifestation of live/work/play systems within the rural landscape. Wherein the prairie landscape was rapidly industrialized to become the productive food-scape for Canadian urban centres, the significance of rural to urban life is now shadowed by the growing ‘want’ for non-renewable commodities such as oil.² The tragic story of the modern family farm is that it must adopt industrial agricultural practices to remain in the rural landscape, bearing the weight of environmental degradation and economic decay as urban consumers demand cheaper food.³ Where family farms and



Abandoned Farmhouse, HWY 857, 2 miles North of Warwick. 2016.



The privately operated Warwick Grain Elevator, Warwick RD, Eastern edge of Warwick Community. 2016.

Disclaimer: all non-sourced photographs have been created by the author.

the rural landscape once fed the urban consumer, it would appear the urban consumer favors an industrialized rural landscape to maintain status. So, how can the architect revitalize rural landscapes by reconnecting consumers to the agricultural process?

The food experience has become sequentially mundane and effortless through industrialization. As urban residents access to locally sourced food becomes increasingly tenuous, restrained by limited access to producer supply, the majority of the urban population becomes overly dependent upon supermarket chains and imported foodstuffs. This has led the average consumer to question the urban food model and react by objectively seeking the experiential value of local food producers. This reveals that urban consumers desire a more socially and culturally integrated food experience - an opportunity for architecture to enhance the relationships built between consumers and the productive rural landscape.⁴

Outside of very specialized programming such as the stereotypical winery, agricultural producers invest little thought towards the architectural process as they

2. Austen, "Oilsands boom dries up in Alberta." In the case of Alberta, Canada and the Fort McMurray Oil Sands project, it is clear that oil dependence is a fragile system that can cripple far too much of the North American lifestyle. Recently the dramatic fall in oil prices mark the bubble burst, as heavy crude production in Alberta has all but stopped, leading to a loss of over 35,000 energy industry jobs.
3. Smaller and Yalan, "The Quest for Commodities." In recognizing the trend of the industrialized nation and the global identity, local becomes commodity expressly sold as tourism, resource, or labour which can be marketed at the global scale. This is most notable in context of China's issues with national food shortages and a quest for food security amongst international trade partners.



Relativity and Imagination in Adaptation.

Perspective of the current adaptations that society attributes to sustainable agriculture. To awake the average consumer from their 'business-as-usual' lifestyles will require jolting visuals. A virtue of art is the necessary critique of social normalcy and the resultant human nature - a sensualization of the argument.

Disclaimer: all non-sourced collages have been created by the author.

inherently understand their own process and utilize the well established industrial shell as vernacular built form. What this form lacks in relativity to landscape and imagination is well compensated by utility and economy, spurred by demands for mechanical efficiency and lending to the rural industrial aesthetic. Architecture stands to reveal the potential of the prairie landscape in symbiotic growth with producer, consumer and community; educating the consumer and producer of the potential for a sustainable agricultural process.

The intent of this thesis is to establish a design model focused on developing resiliency for rural landscapes and the producers that steward over them. Integrating architecture with community and industrial design will build stronger rural communities that support the entrepreneur producer and the local process so critical to defining vernacular character. Embracing the nature of place, architecture can impress upon producers and consumers how they ultimately define the role of their rural landscapes in relation to urban growth.

This leads my research to Aldo Van Eyck and his efforts to develop a process of architectural design which sought a reciprocal architecture that could balance two opposites such as tree/leaf, house/city, and urban/rural. More so, Aldo Van Eyck's work with Team 10 would prove crucial to his efforts to develop his 'Aesthetics of Number' theory - high quality architecture for every person. Van

4. Dee Hobsbawn-Smith details the entrepreneurial spirit of Albertas generational family farm in her book, *Foodshed: an Edible Alberta Alphabet*. Generational family farms and hobby farmers have developed sustainably produced, value-added food products for local consumers to maintain their rural lifestyles.

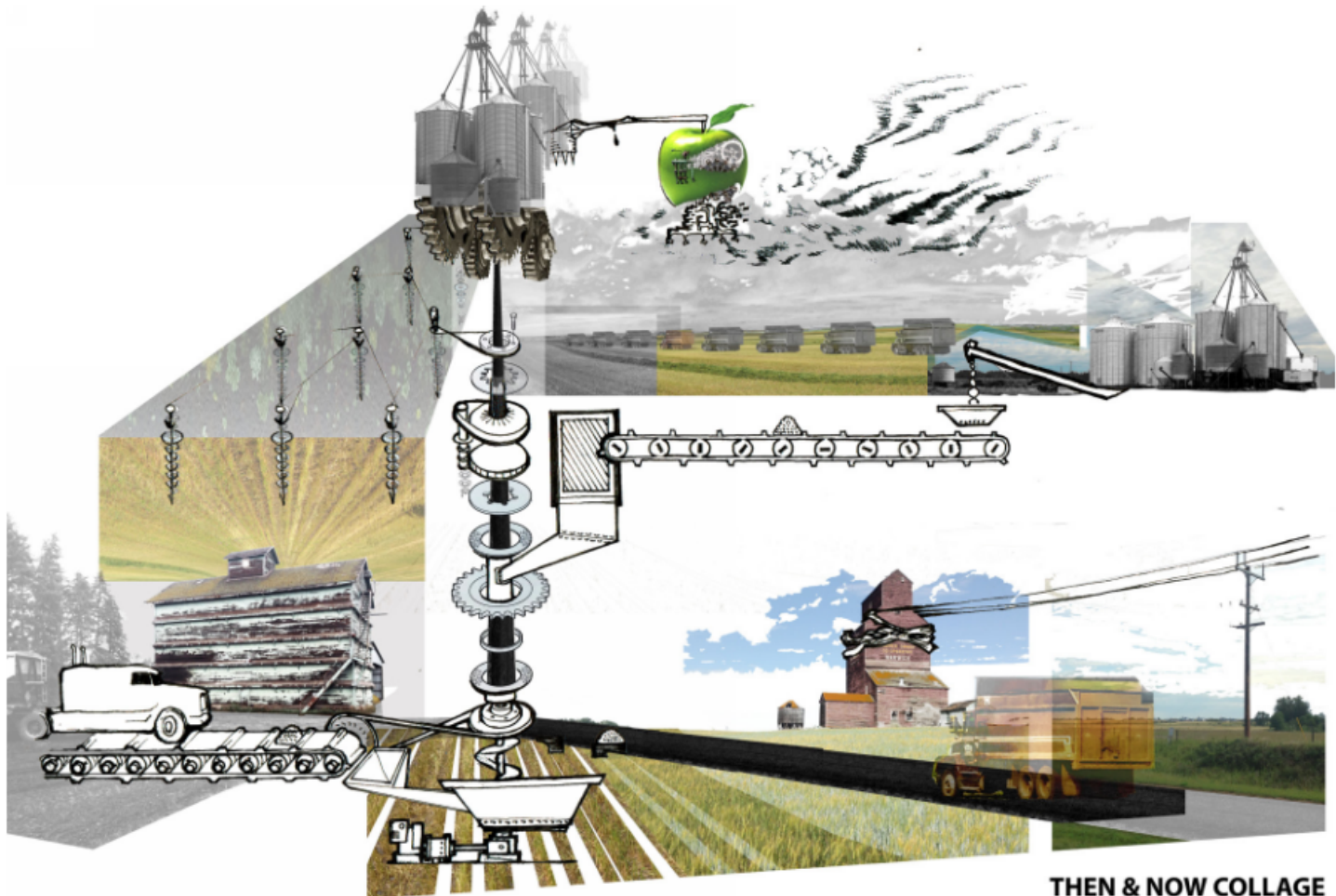

THEN & NOW COLLAGE

Then and Now Collage, Warwick Community.
A perspective of the mechanized rural landscape and inherent cycles of degradation.

Eyck's development of the Amsterdam City Playgrounds will prove a crucial case study as to how architecture can integrate relativity and imagination into socially and culturally metamorphic landscapes to induce positive character building experience.

When considering the power of a single image to inspire emotion, the intent of architecture is to reconnect consumers with the landscapes that sustain them. The farmers process is the program for a new public architecture that directly integrates the consumer experience into the production cycle; guiding the architect to design through the agricultural product itself. This results in an architecture or product that, when recognized by the urban consumer, will inspire a personal connection to a sustainable rural landscape. When the product is sought by the consumer, it should stimulate a stream of thought which reminds users of the producers efforts to provide such a product, and simultaneously engage new associations between the consumer and the products experiential value. Creating intrinsic value through the product and the architecture is inherent to their integration as typological anchors into the rural landscape and the consumer experience.

I will use the case studies of Warwick community, the Grandparent Farm, the Parent Farm and the Offspring farm to relate the past, present, and future states of the rural landscape as understood by rural producers. Historically, as the generational family farm precedes the urban condition - and the necessity for an industrial agriculture machine - it remains the most successful model for rural resiliency. Specifically, the values of the generational farm

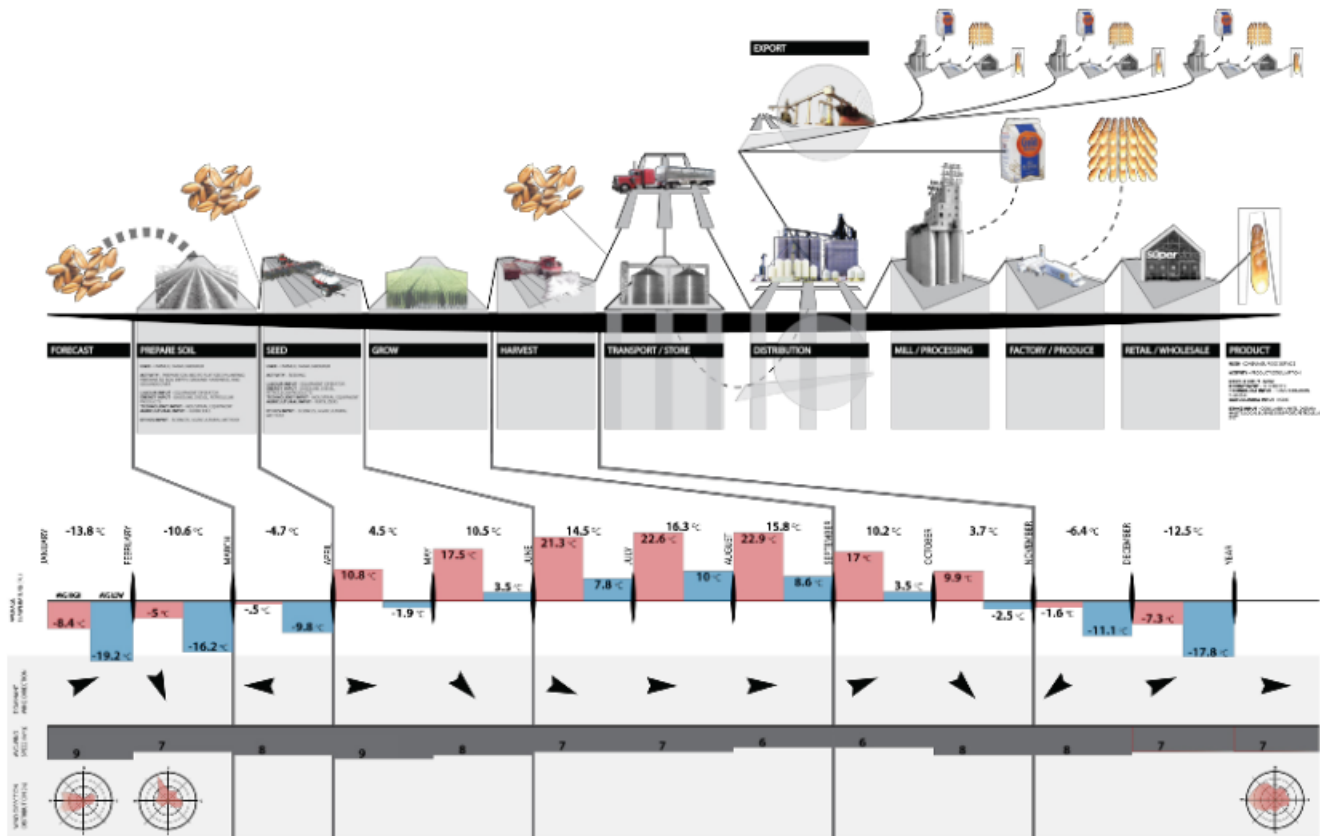

Industrial Food Cycle.

As producers operate seasonally, they must accommodate their process and aspiration to natural cycles, assuming the greatest economic risk within the food cycle. Industrial and consumer cycles monopolize the efforts of the producer, and the architectural cycle is only apparent where consumers are most fallible; the supermarket.

demonstrate the reciprocal nature of the rural producer to retain vernacular social and cultural processes that define their individual character in the face of rapid economic and environmental adaptations. Reciprocal is the ability of the rural producer to competitively value-add their agricultural process through an entrepreneurial spirit that is focused on maintaining their rural lifestyle.

For the architecture to competently display the rural producers entrepreneurial spirit, the architect must understand the design, influence, and language of the various systems which have so greatly transformed the rural landscape into an industrial landscape. Mapping these systems as they intersect the generational farm will reveal the opportunities for architectural programming that can engage the consumer in a sustainable agricultural process. It is important to consider the productive food-scape and that food becomes a material object with infinite associations to the human experience, fulfilling multiple functions when considered as a whole, and capable of meeting the most discriminate details when anticipated as a part. This is the nature of the productive rural landscape and the study of architecture; a reciprocal understanding of the part to the whole and the potential of the in-between.⁵

Given that new generations of producers are capable of rapidly assimilating new technologies into existing process, producer networks have become the vehicle through which sustainable agricultural process will disseminate through the rural landscape. Presently, Canadian farmers are eager to

5. Christian Norberg-Schulz documents the phenomena of the in-between space in his book, *The Concept of Dwelling*, and the notion of the vernacular building typologies as informing the individuals character development.

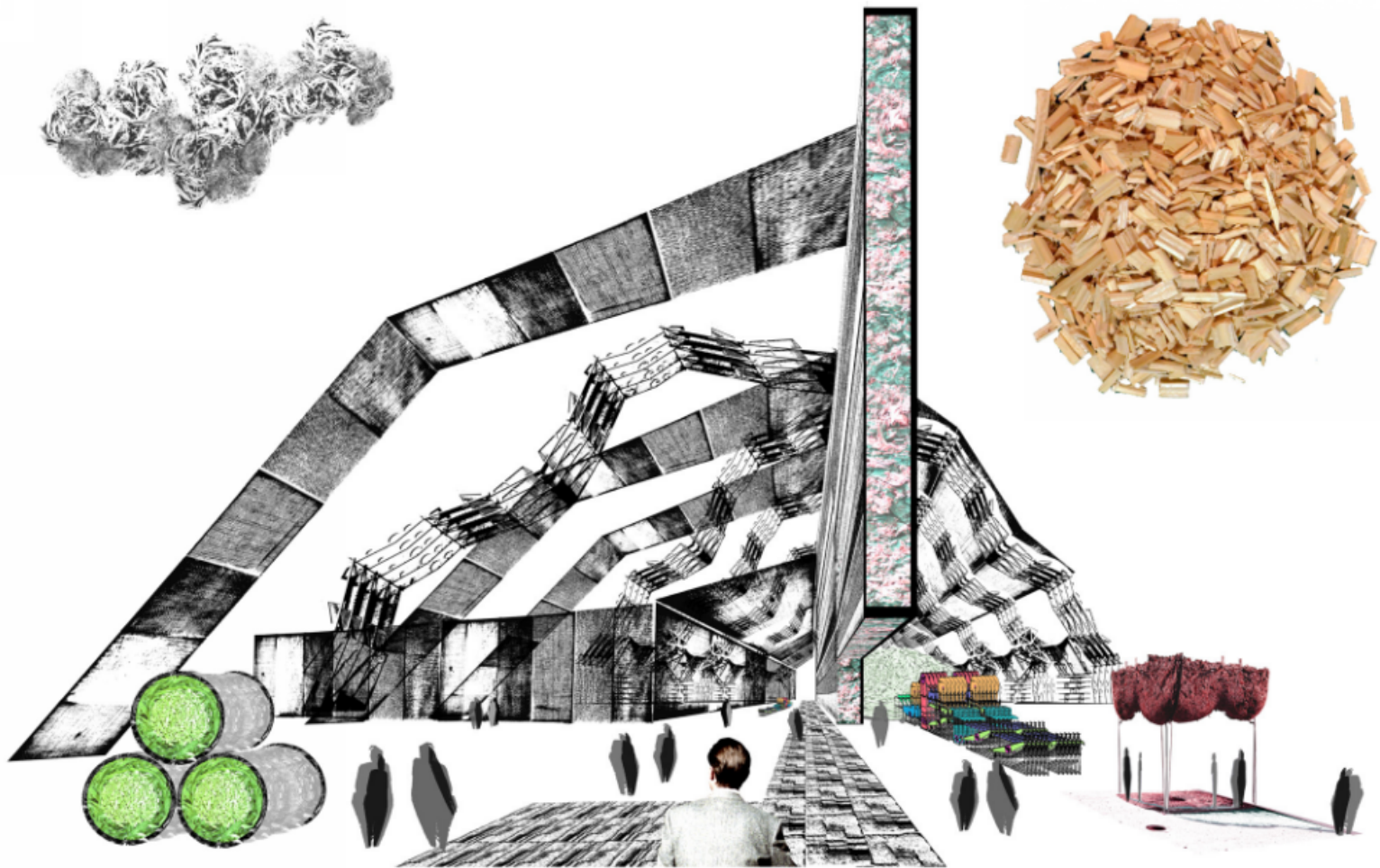

Hemp Collage.
Imagining the consumer experience through the Industrial Hemp Process

reignite a Canadian Hemp industry, spurred by changes to the Federal regulations and growing public awareness. As “the world’s premier renewable resource, hemp has been [a] source of food and fibre for the past 10,000 years.”⁶ Industrial Hemp stands to revitalize rural landscapes for its sustainable value. Because industrial hemp will inevitably require industrial agriculture, the Alberta prairie is more than established to accommodate the mass-production of sustainable resources for global consumption. Furthermore, the generational family farm stands as the vehicle for a sustainable rural experience, and the ultimate venue to disintegrate the preconceived and established stigmas which surround industrial hemp and the rural landscape.

The utilization of established models for sustainable community design, low energy buildings and modular building design will accelerate the design process of resilient rural communities, and provide an inhabitable consumer experience that benefits the agricultural process. Given the present development of agricultural building materials, the architect can explore the rural landscape as the provider of sustainable building product inherent to the agricultural process. The true value of the architecture is to orchestrate the consumers experience through this reimagined system - for the architecture to relate the knowledge, experience and anticipation of the rural producer instantaneously to the consumer. As resident and successive steward of an industrialized rural landscape, I intend to explore the potential of architecture to remediate and revitalize the rural condition.

6. Alberta Agriculture and Forestry, “*Industrial Hemp*”.

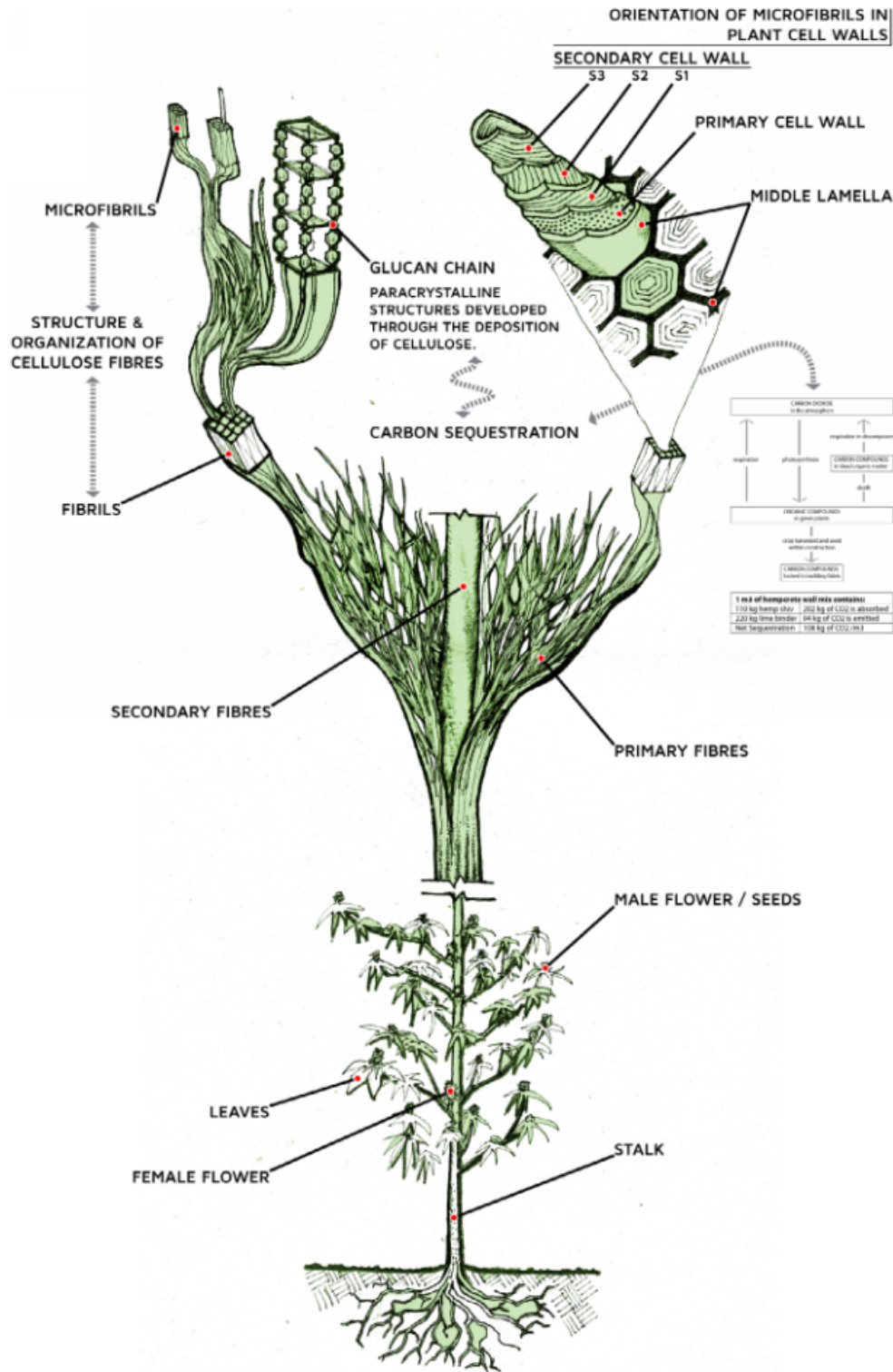

The Industrial Hemp Plant.

As a agricultural product closely tied to the industrial agricultural process, Industrial Hemp bears the same mechanical properties as timber, but provides greater economical, environmental, social and cultural implications towards sustainability.

Chapter 2: Conclusion

Given the nature of modern consumerism, the conclusion of this thesis document is summarized in the form of a trade catalogue fashioned after a Sears mail order barn catalogue published in 1928. The purpose of a trade catalogue was to quickly orient rural producers towards a conventional agricultural practice. New technologies, educational material and a vernacular building process were disseminated at minimal cost through the postal service, and allowed for the proliferation of a prairie landscape. As industrial agriculture has already established permanence through corporatized agri-business, a resilient and sustainable agriculture must be rapidly disseminated to consumers to spark interest and debate.

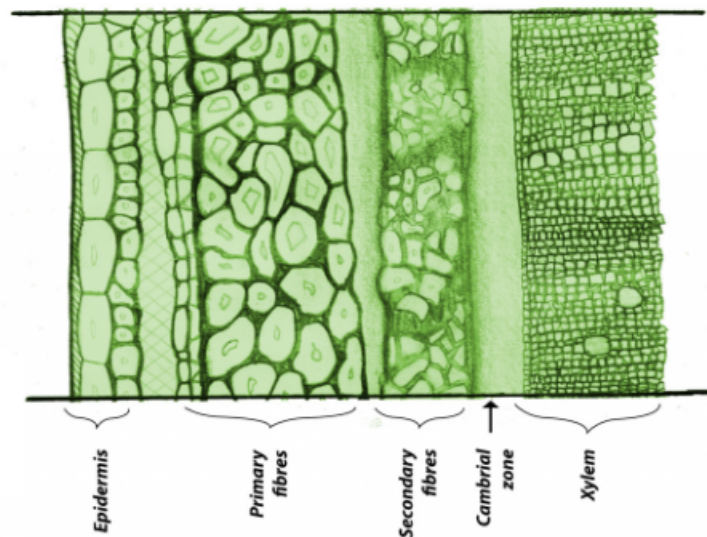

The Hemp Plant Revealed.
Exposing the Hemp plants cellular assembly.

Internodal Growth of Hemp Stalk

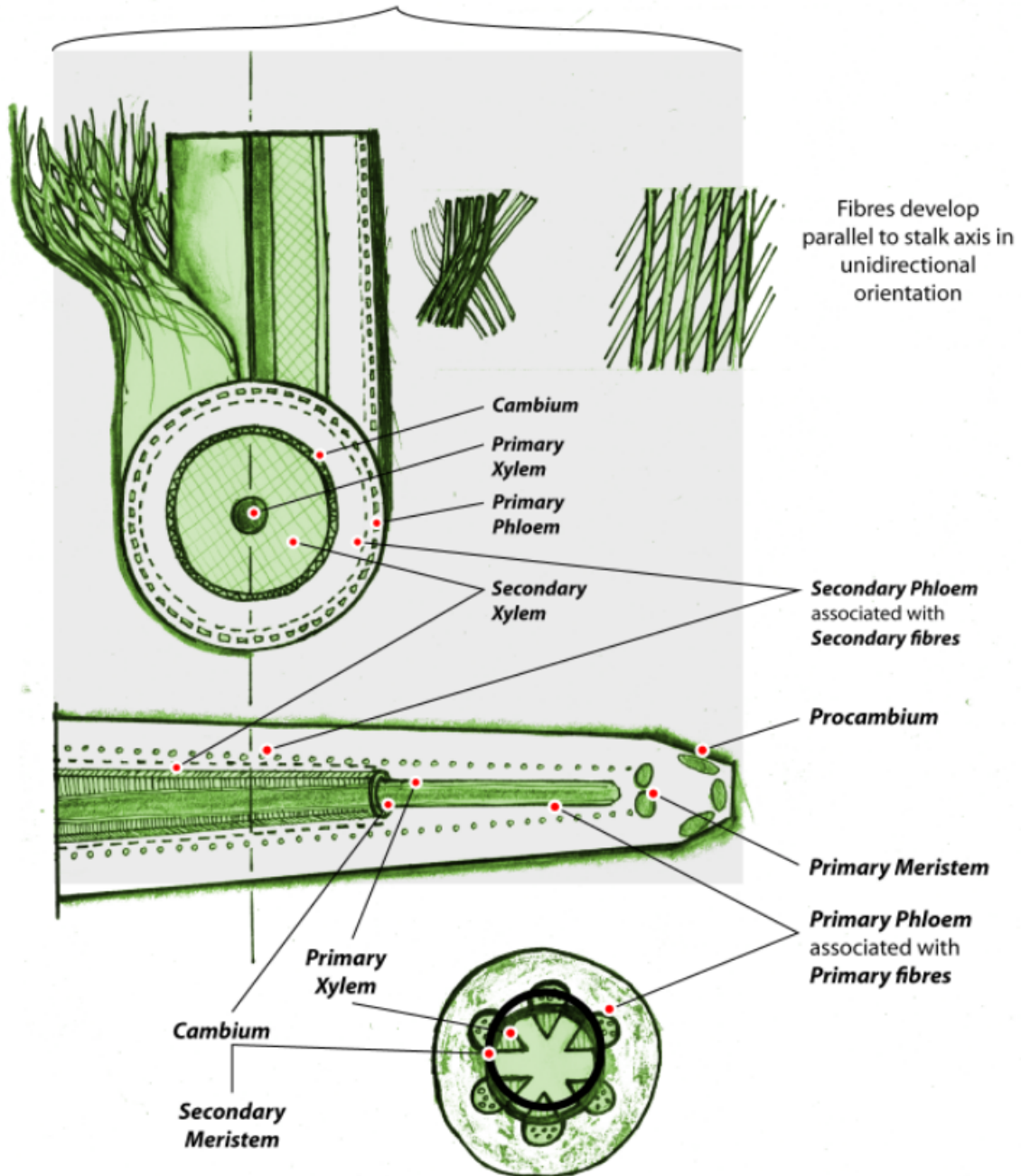

The Hemp Plant Revealed.

Exposing the Hemp plants growth process and mechanical attributes. The advantage of Hemp fibre is a natural cross-layering of micro-fibrils that allow the Hemp stalk to grow to heights of 14ft.

Modern Farm Hemp Buildings



Grow Your Sustainable Community Today!





The HempWorks Local Cooperative & Future Farms Media GUARANTEE

HempWorks Local Co-operative is committed to the Permaculture Model for Sustainability. As a provider of economical and sustainable building materials, HempWorks Local builds resilient agricultural communities.⁷

Future Farms Media is committed to enhancing the opportunities for Canada’s next generation of family farms. The purpose of this publication is to reveal the unbound potential of rural communities to building a sustainable agricultural process.⁸

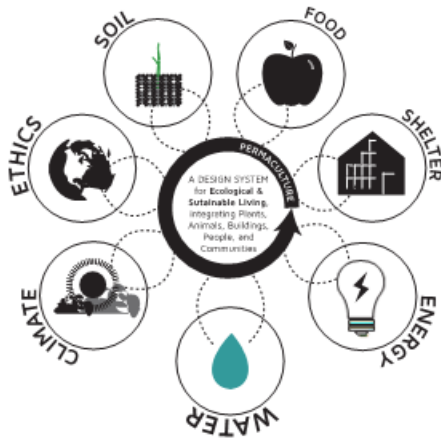

Permaculture Framework

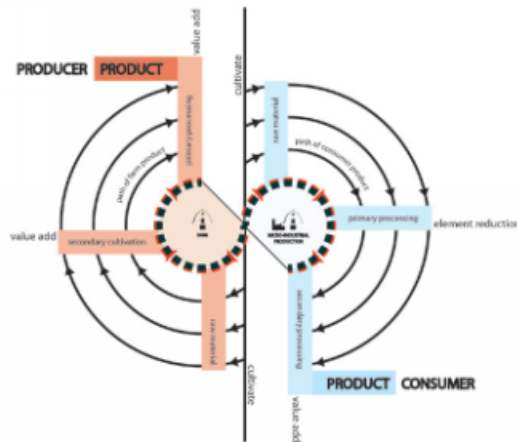

Product Sustainability Model

Permaculture outlines the basic principles for creating permanent agriculture. Sustainable materials must act dually, as potential process inputs and outputs, to ensure the greatest conservation of energy.

7. See Appendix A: The Barn That Raised Me, “Community Resiliency,” 187-197.

8. See Appendix A: The Barn That Raised Me, “Schematic Sustainability”, 197-207.



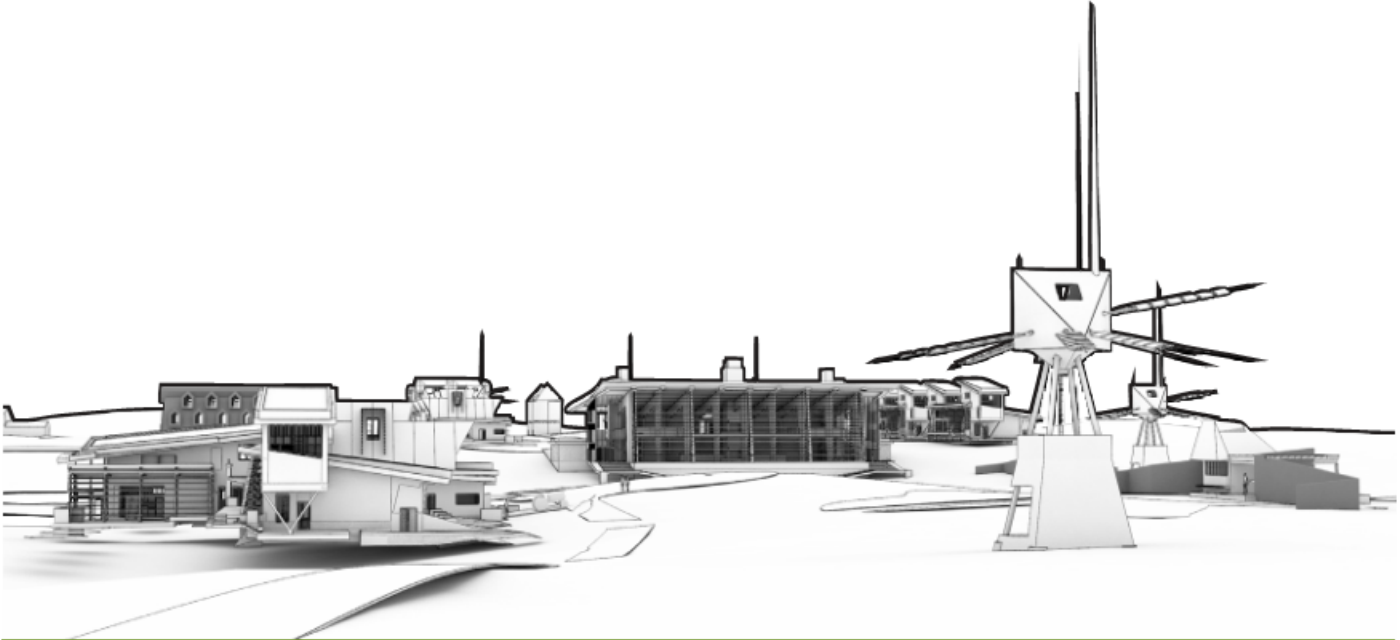

Build Resilient Communities with Hempcrete

Design-Build your Generation Family Farm with sustainable and economical building materials. Building with Hempcrete means that young farmers can incrementally grow their Value-Add Process with locally sourced and developed Biofibres.⁹



Fire Resistant

Economical



Pest Resistant

Super Insulating



Mould Resistant

Hygrothermal

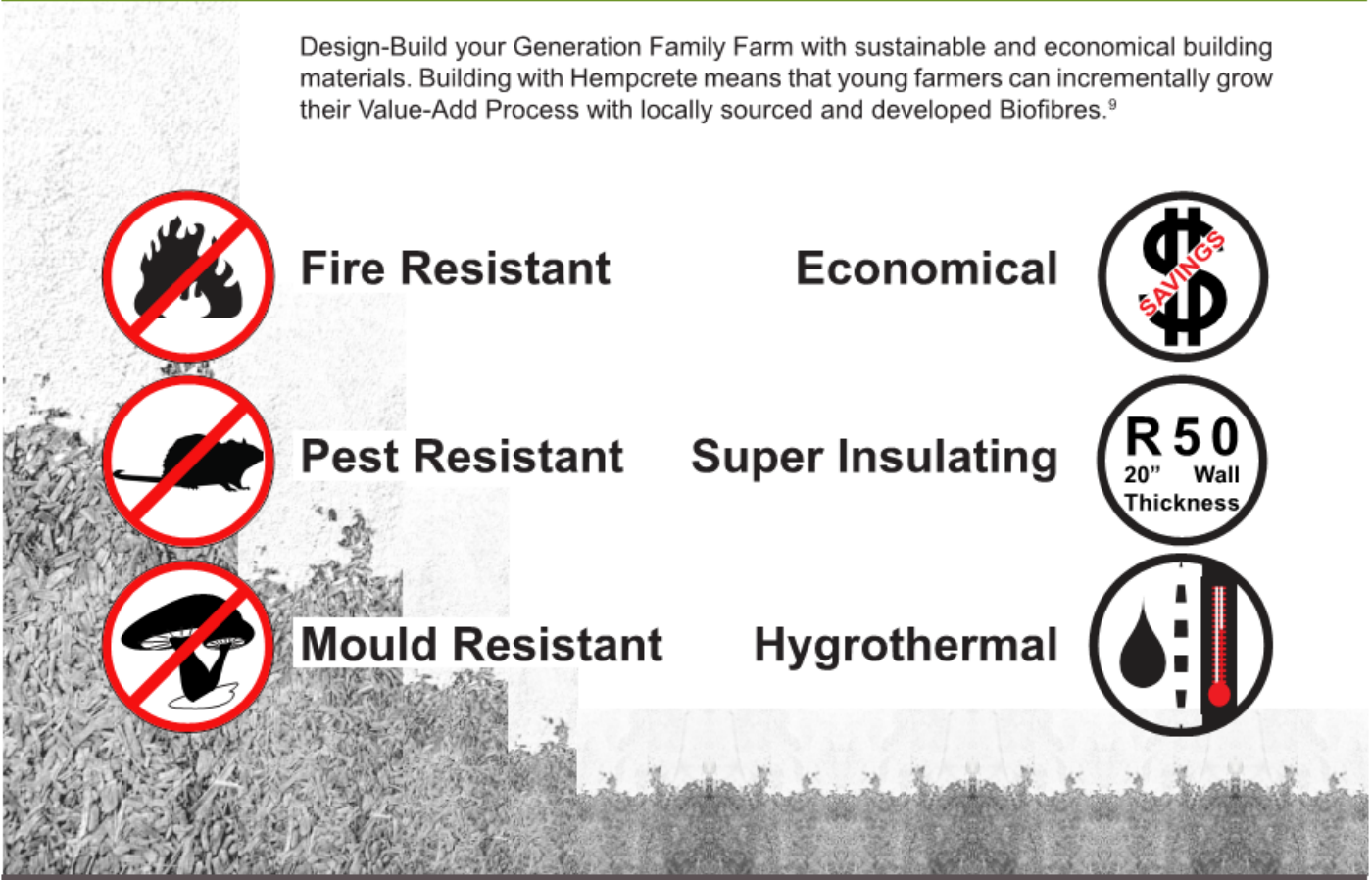

9. See Appendix B: The Barn I'd Raise, "Energy Economics," 207-213.

The Rise and Fall of the Rural Prairie Community

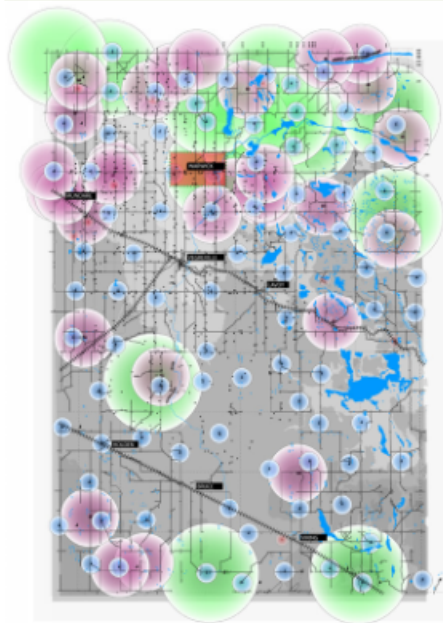

VEGREVILLE AND SURROUNDING AREA c. 1918

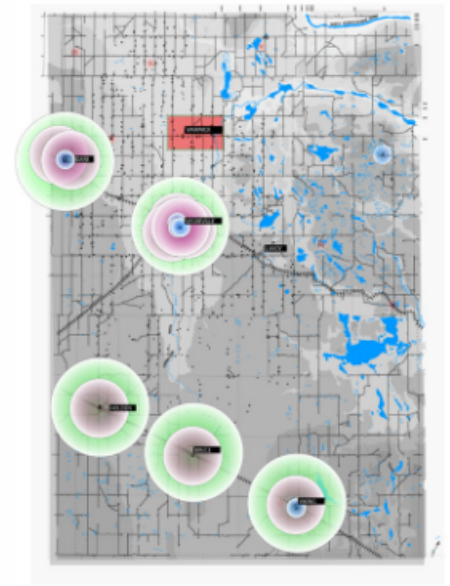
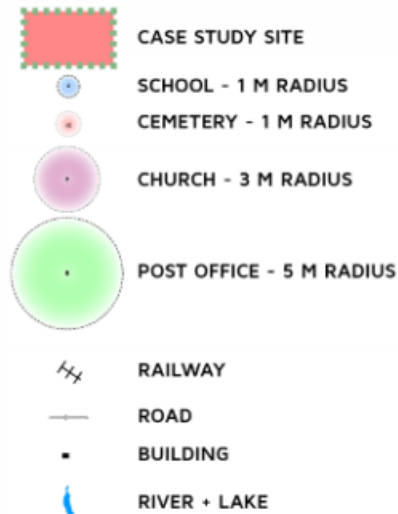

VEGREVILLE AND SURROUNDING AREA c. 2016



Resilient Rural Community

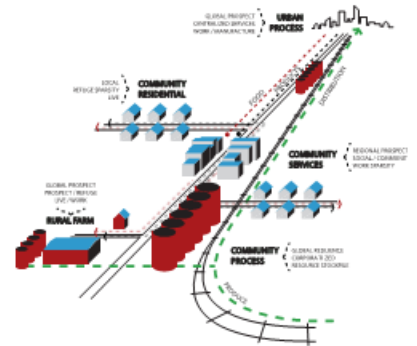

Industrialized Rural Community

Historically, prairie settlers only survived because of their ability to perform the agricultural process. In time, communities grow from the farms through the addition of social, cultural and economic programs that sustain the Rural Lifestyle. Reciprocal relations between urban and rural maintained an equal opportunity and holistic approach to the Live/Work/Play cycles of human habitation.¹⁰

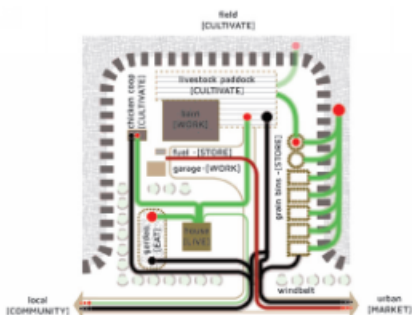

Resilient Generational Farm Process

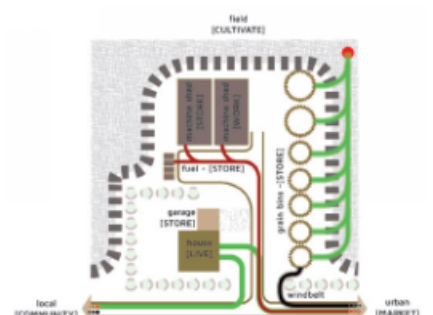

Industrialized Generational Farm Process

The decomposition of the rural fabric into centralized, urban communities has isolated the rural producer - the result of industrialization. As the interface between local food and urban consumer is presently restricted by convenience, then rural producers must become more convenient, or, become a preferred social and cultural experience altogether.¹¹

10. See Appendix B: The Barn I'd Raise, "Section 1: Observation and Theory," 61-65.

11. See Appendix B: The Barn I'd Raise, "The Rural Experience_Play," 89-99.

An Industrialized Generational Family Farm

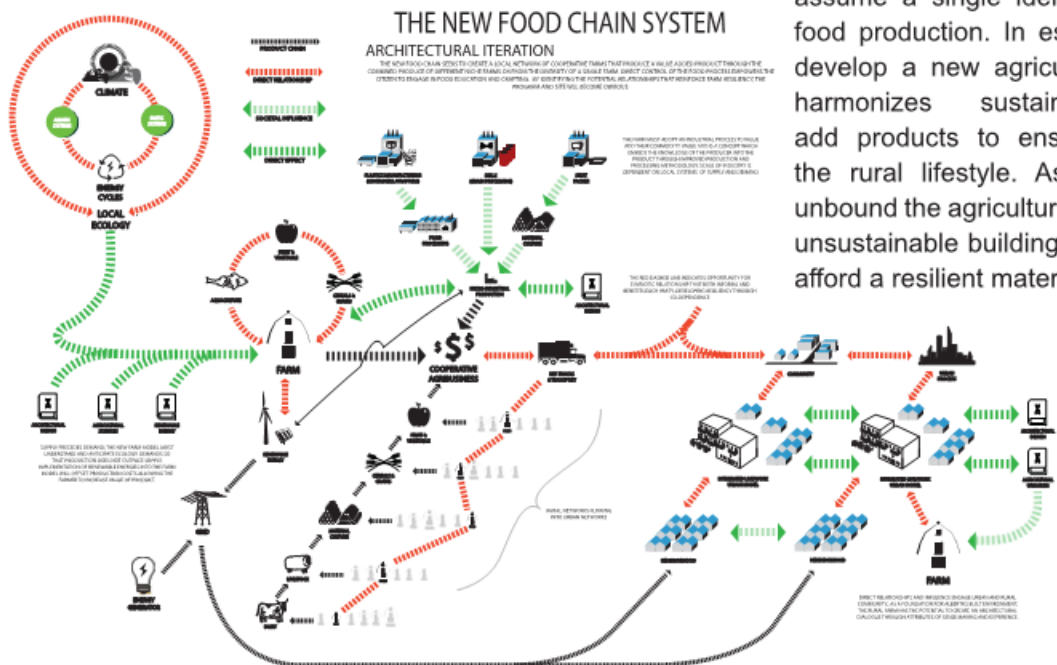
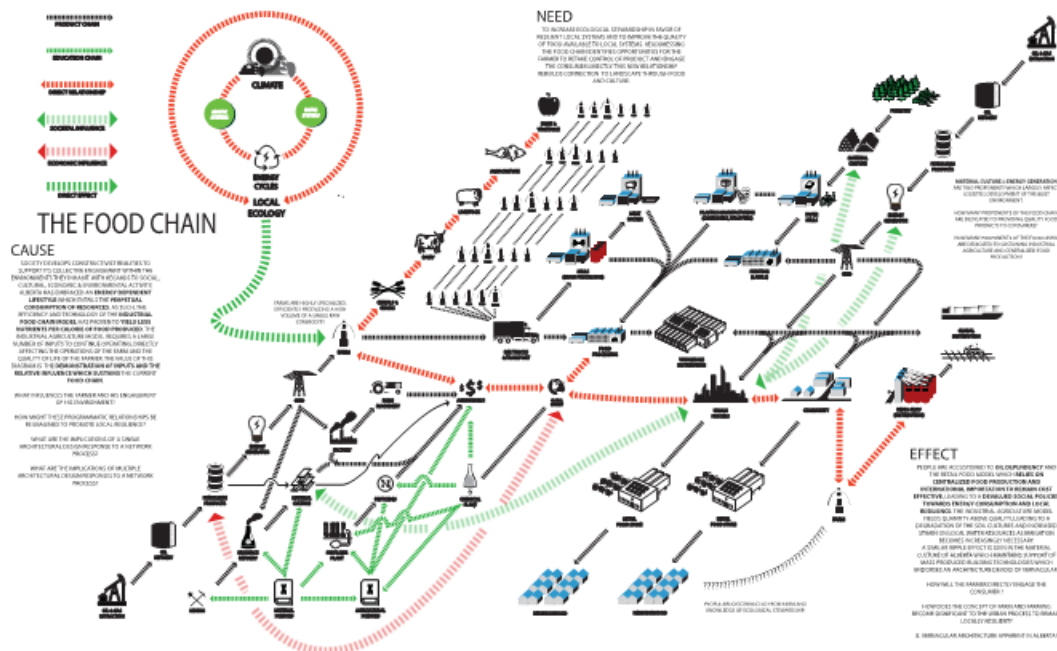

If rural producers intend to maintain their prairie stories, then agriculture must not assume a single identity or approach to food production. In essence, it is time to develop a new agricultural standard that harmonizes sustainability with value-added products to ensure the viability of the rural lifestyle. As new technologies unbound the agricultural product to mitigate unsustainable building practices, bio-fibres afford a resilient material culture.¹²

A Resilient Agricultural System

12. See Appendix B: The Barn I'd Raise, "Community Resiliency," 187-197.

The Resilient Generational Family Farm

The Grandparent Farm is essential to passing specialized knowledge and skills to the Offspring generation. Initially a dairy farm, agricultural process evolved to beef cattle, then equestrian breeding. Personal needs necessitated annual vegetable gardens and egg production.¹³

- Farmhouse
- Producer programming
- Livestock programming
- Storage programming
- Neighbour building
- Garden / Fruit Orchard
- Feedstock storage area
- Productive landscape
- Road
- Fenceline

The configurative assemblage of the Grandparents barn into a germinal program resembles the organic evolution of medieval cities that grew from a naturally occurring circulation routes.

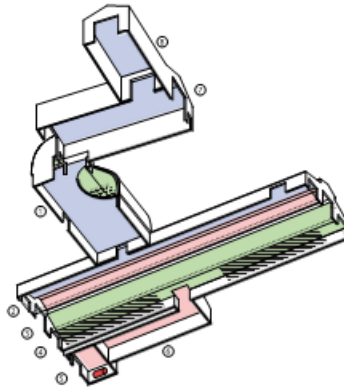

A Traditional Approach to Building Agricultural Buildings



- 1 Plywood barn w/ hayloft, uninsulated
- 2 Dairy barn, livestock feed alley, uninsulated
- 3 Dairy barn, producer feed alley, uninsulated
- 4 Dairy Barn, feed and equipment storage, uninsulated
- 5 Milkhouse, insulated
- 6 Milking parlour and Chicken Coop, insulated
- 7 Cattle barn, uninsulated
- 8 Cattle barn, uninsulated

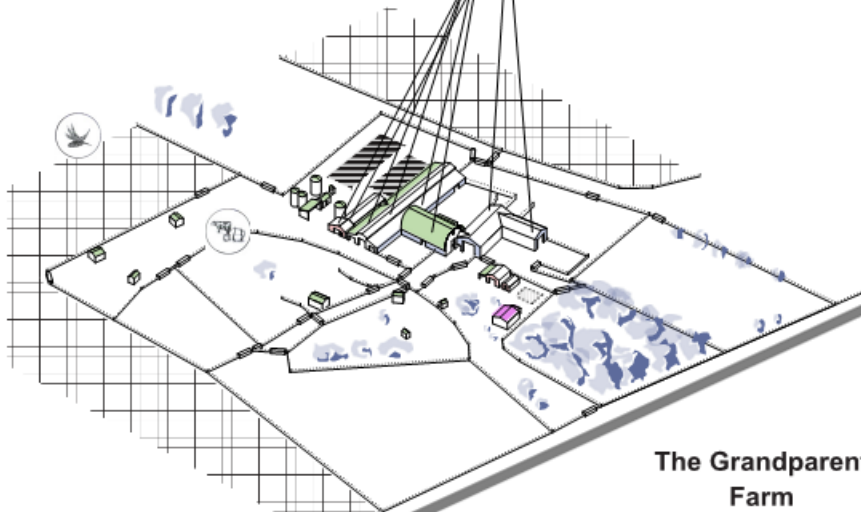

The Grandparent Farm



DAIRY
Cow/Calf
Process



CEREAL
Grain
Process



EQUESTRIAN
Breeding
Process

**Agricultural
Process**

**Agricultural
Enthusiast**

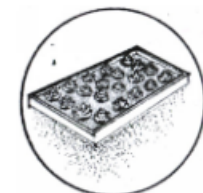

GARDEN
Produce
Process



CHICKEN
& EGG
Production

13. See Appendix A: The Barn That Raised Me, "The Generational Farm_Live," 71-79.

The Industrial Family Farm

A stereotypical family farm in Alberta's rural landscape. Industrial agriculture provides less work and larger harvests at what cost? The Parent Farm reveals a contemporary approach to agriculture and the necessity for entrepreneurialism to stay economically competitive.¹⁴

B E E F
Cow/Calf
Process



**INDUSTRIAL
MECHANIC**
Service



CEREAL
Grain
Process



**Agricultural
Process**

**Agricultural
Enthusiast**

EQUESTRIAN
Enthusiast



GARDEN
Produce
Process

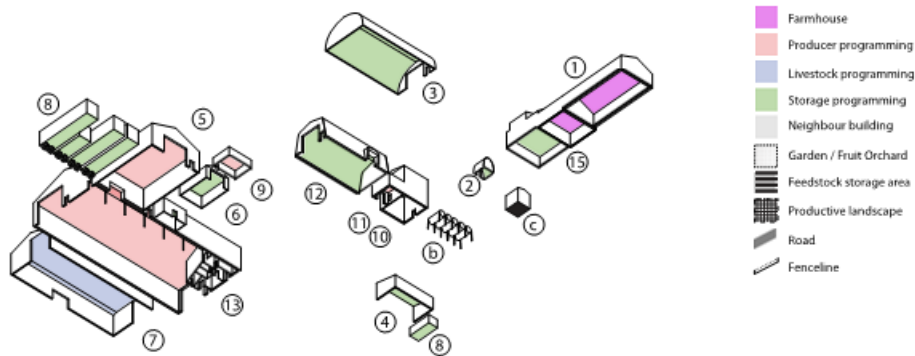
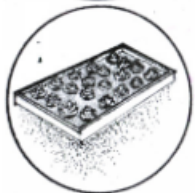

A Modern Approach to Building Agricultural Buildings

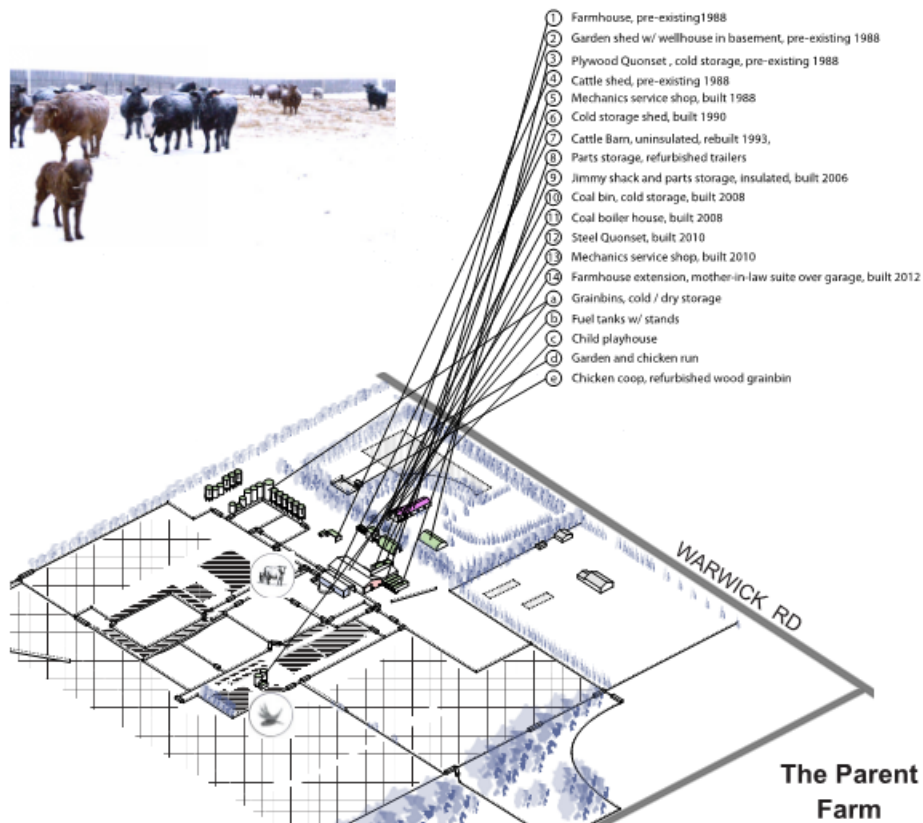

14. See Appendix A: The Barn That Raised Me, "The Value-Add Process_Work," 79-89.

A New Public Architecture for Sustainability in Alberta

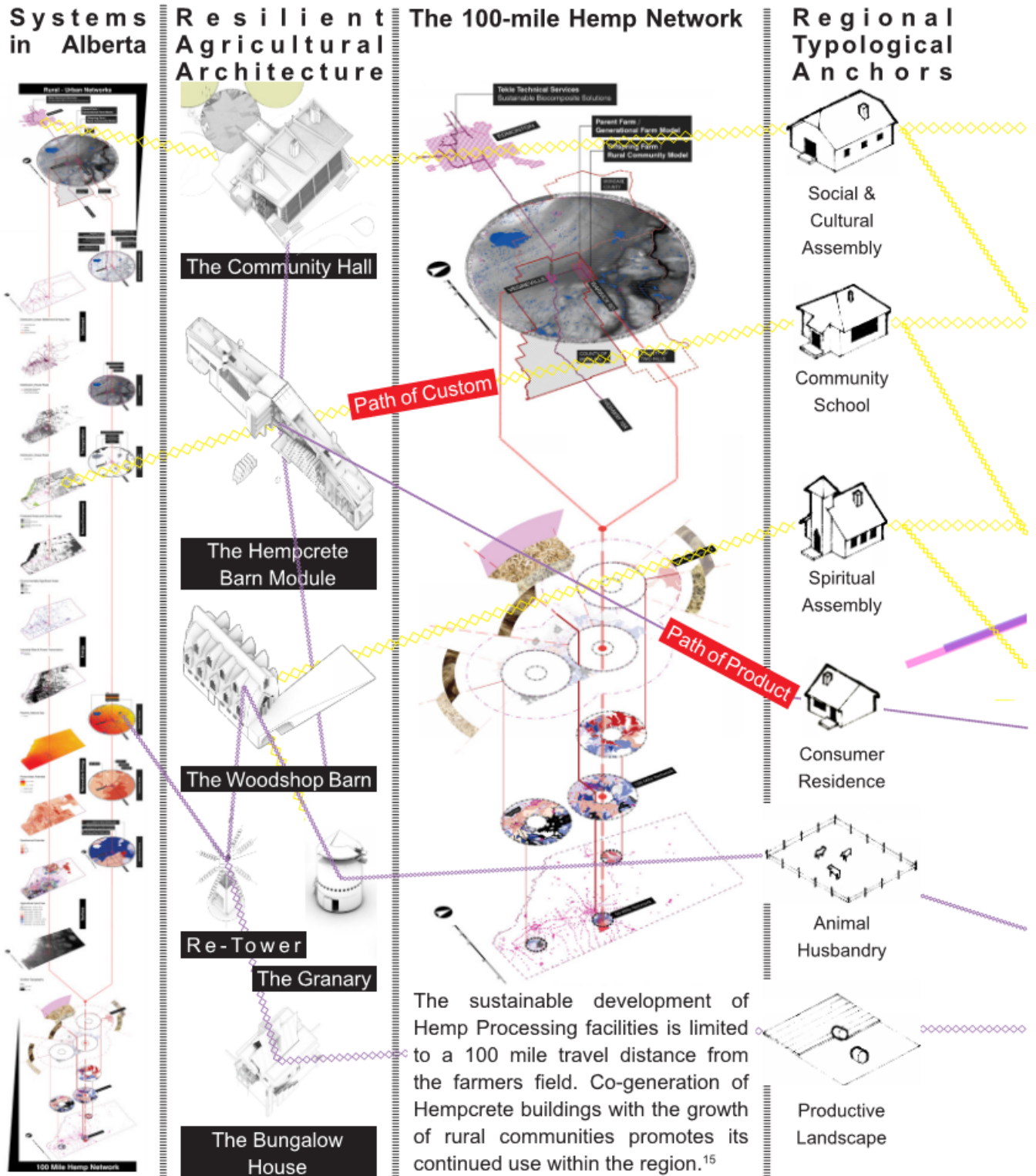

15. See Appendix B: The Barn That Raised Me, "Section 1: Rural Reclamation," 217-255.

Networking Resilient Communities In Warwick, Alberta

Local Agricultural Products

If it takes a village to raise a child, then it will take a community to raise a city. Rural producers knowledge and craft is passed to the urban consumer via their product and its associative relationship, catalyzed by the users imagination.

Local Typological Product

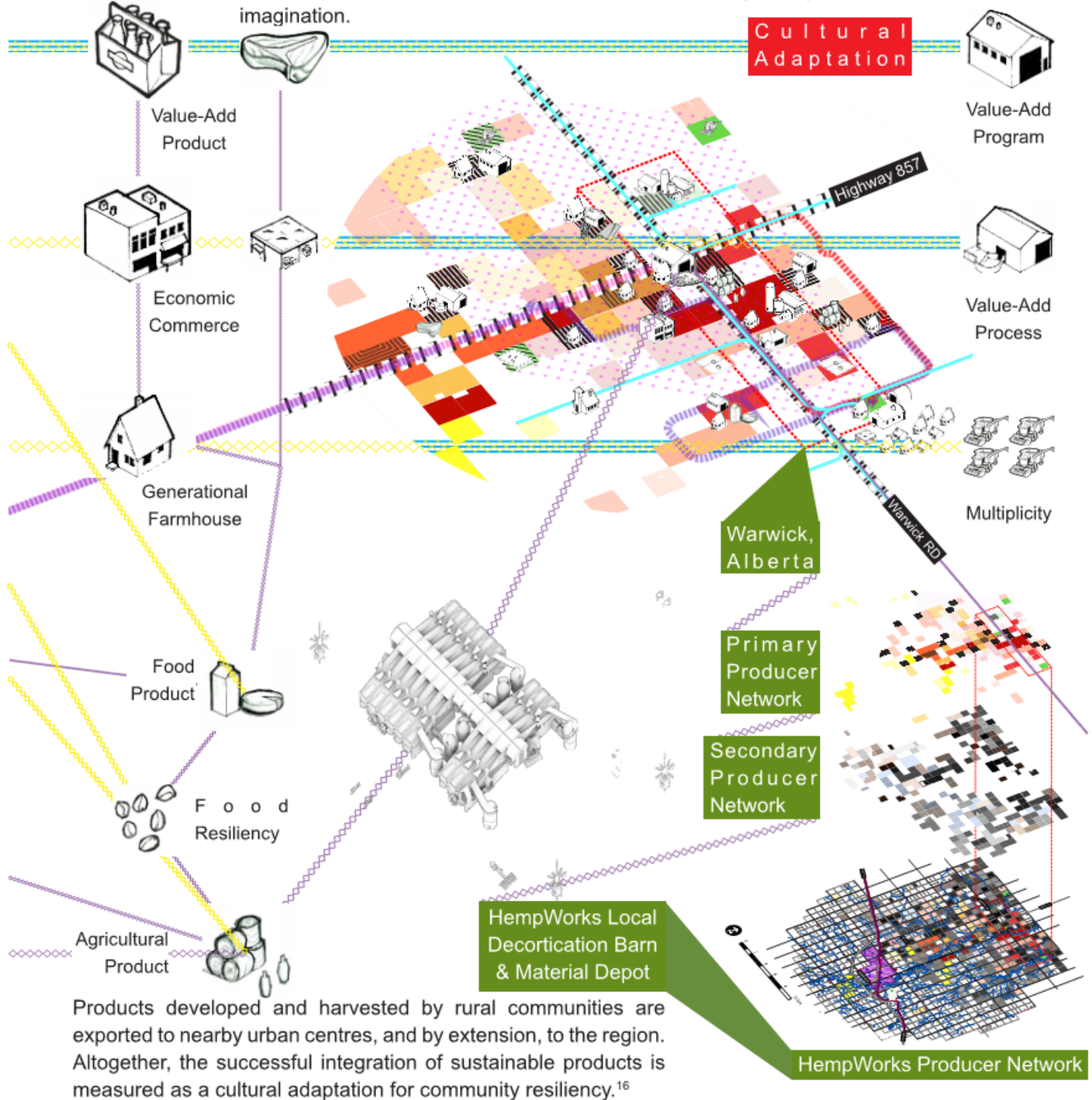

Products developed and harvested by rural communities are exported to nearby urban centres, and by extension, to the region. Altogether, the successful integration of sustainable products is measured as a cultural adaptation for community resiliency.¹⁶

16. See Appendix B: The Barn That Raised Me, "Section 1: Rural Reclamation," 217-255.

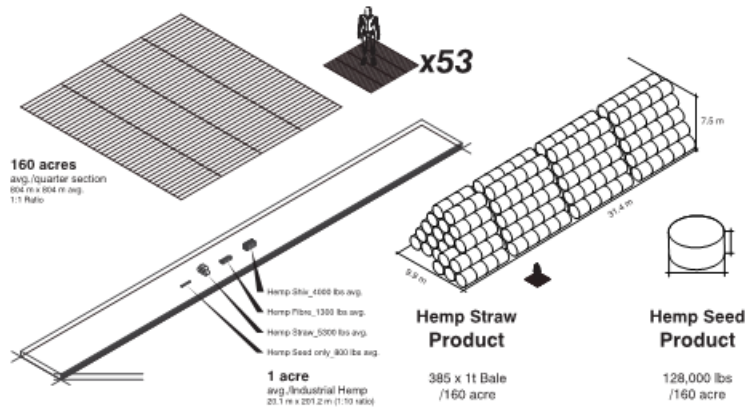
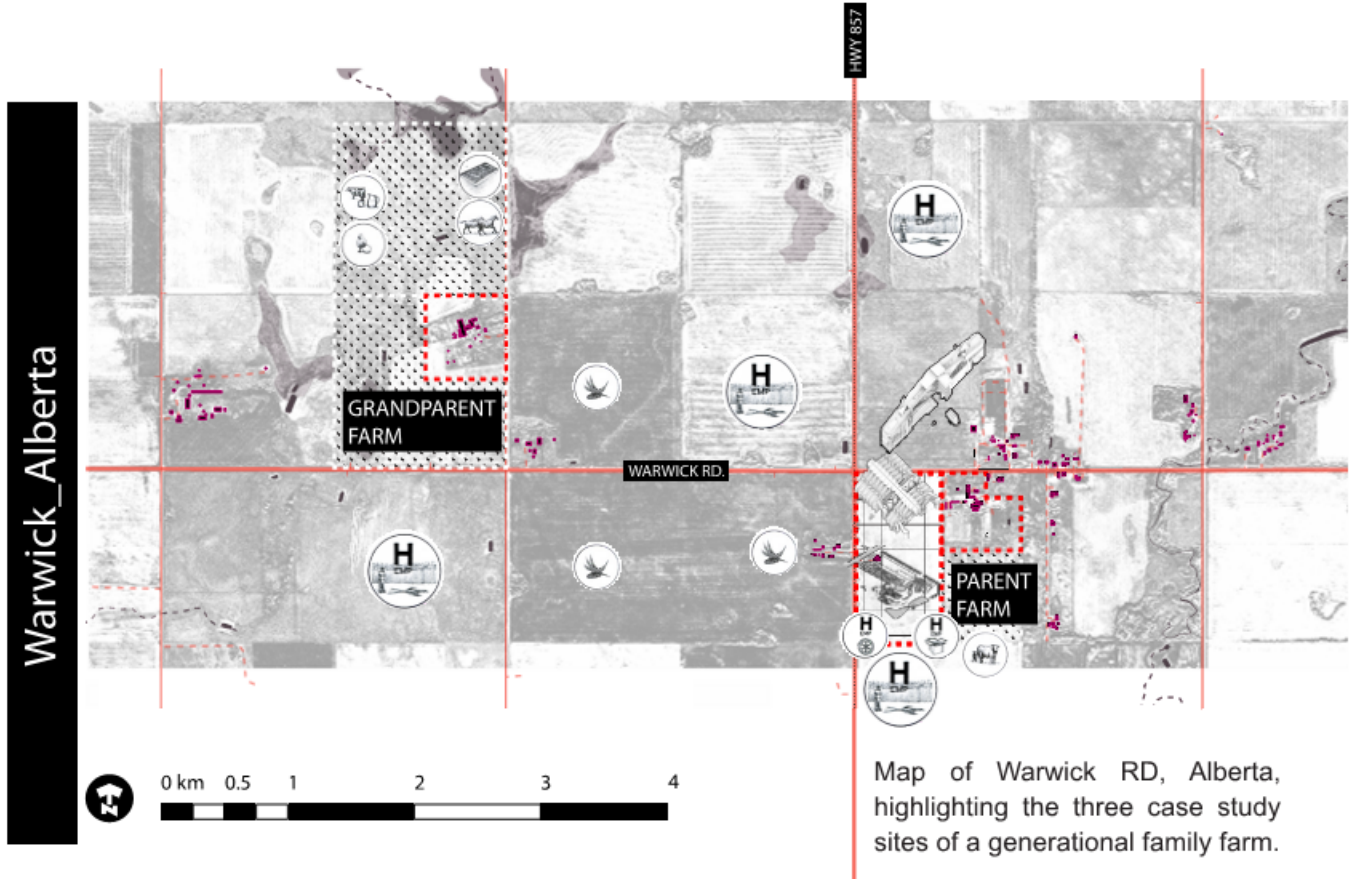

Single Producer Hemp Production
_1 Quarter Section

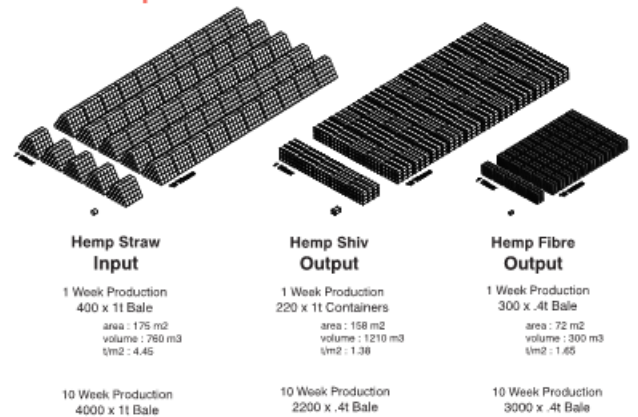

Commercial Decortication Facility
_10 Week Input and Output

Hempcrete and the Aesthetics of Number

To understand the Hemp network is to measure the quantity and quality of the agricultural produce. Consequently, 160 acres of cropland will provide 385 tonnes of Hemp straw annually, producing enough shiv for 53 DOR houses. 53 producers, each sowing 160 acres of Hemp each year, would provide sufficient feedstock for a 10 t/hour processing capacity, Bio-fibre Decortication facility.¹⁷

17. See Appendix B: The Barn That Raised Me, "Rural Networks_Economic," 237-247.

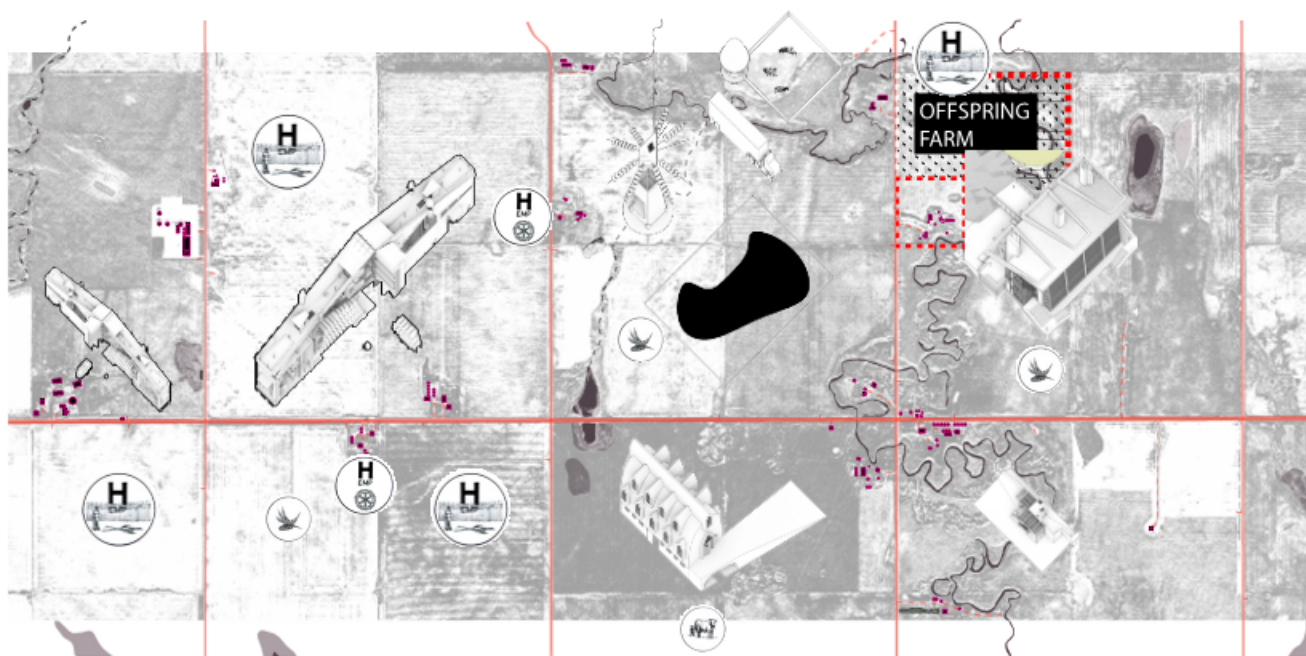

Legend

- Circulation
- Study Site
- Foliage
- Buried Gasline
- Livestock Use by Season
- Producer Use by Season
- Building
- Cropland
- Waterbody
- Powerline
- Year Round
- Livestock Enclosure
- Intermittent Waterbody
- Winter
- Property Boundary
- Exposed Feedstock Storage
- Spring
- Homestead
- Garden
- Summer
- Storage Structure
- Seasonal Equipment Storage
- Fall
- Service Building
- Seasonal Equipment Storage
- Year Round
- Winter
- Spring
- Summer
- Fall
- Circulation of Livestock
- Building Access

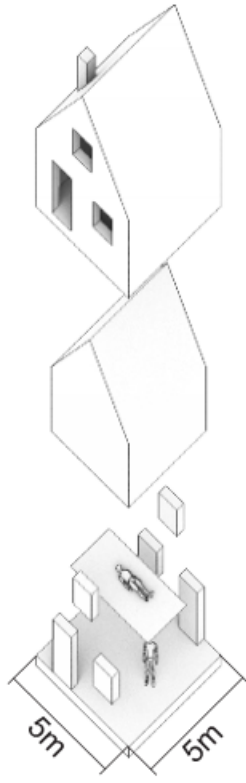

Continuous Hempcrete Envelope

Simple Interior Volume with Vaulted Ceiling

Minimal Dwelling Concept

DOR House
Double Occupant Residence

- Occupants: **2**
- Floor Area: **25 m²**
- Hempcrete Building Envelope: **45 m³**
- Cost of Hempcrete: **\$ 5280**

Providing DOR houses to young farmers reveals investment towards a resilient rural community. The primary objective of HempWorks Local is to provide economical and sustainable building materials for rural producer.¹⁸

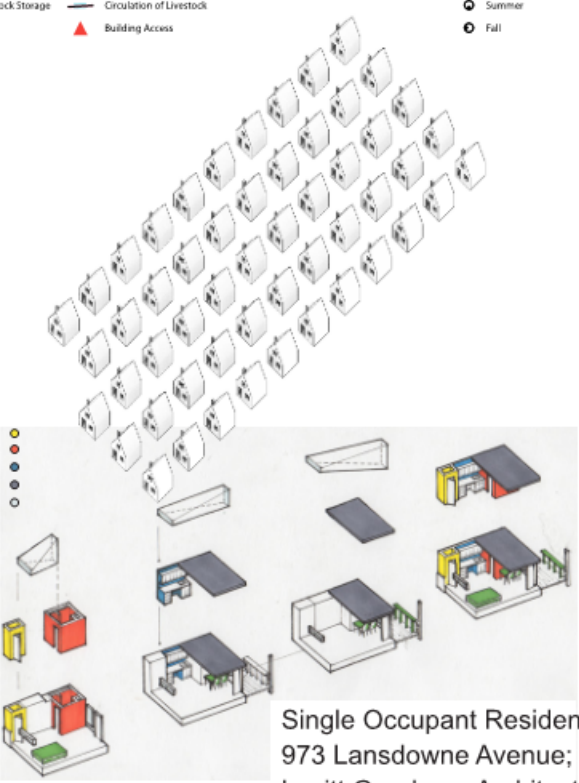

Single Occupant Residence, 973 Lansdowne Avenue; Levitt Goodman Architects

18. See Appendix B: The Barn I'd Raise, "Rural Systems_Social," 247-253.

The Mechanical and Ecological Advantage of the Industrial Hemp Plant

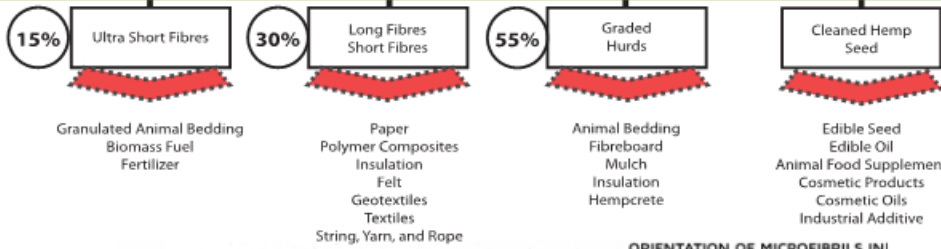

H E M P
S H I V

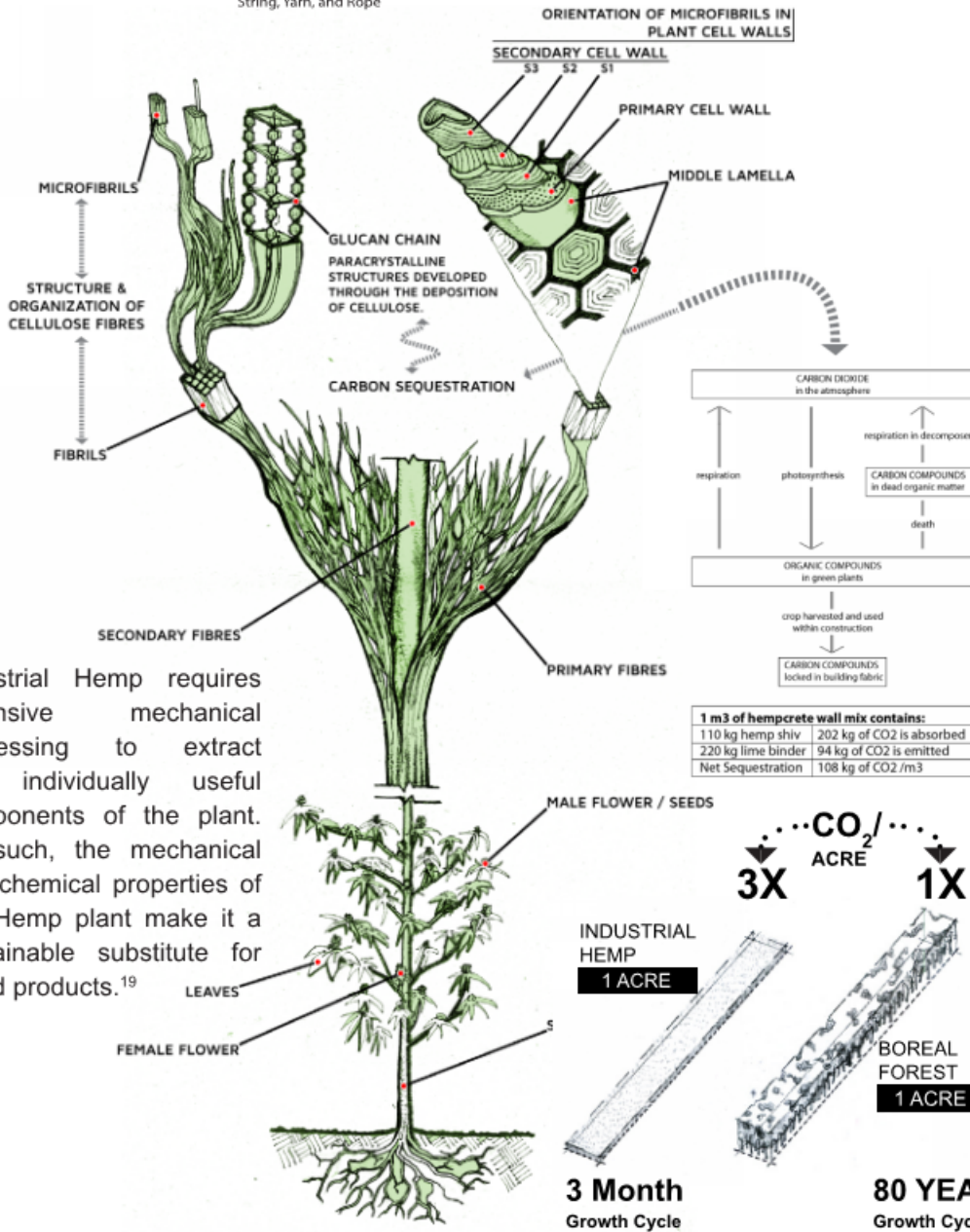

Industrial Hemp requires extensive mechanical processing to extract the individually useful components of the plant. As such, the mechanical and chemical properties of the Hemp plant make it a sustainable substitute for wood products.¹⁹



H E M P
F I B R E

19. See Appendix A: The Barn That Raised Me, "Shiny Pebbles and Large Ripples," 179 - 187.

Value-Add your Sustainable Agricultural Process with Hempcrete

DE-GUMMED
H E M P
F I B R E



Hemp
4 part



Water
1 part



Lime Binder
1 part

=



Wall thickness (mm)	Wall thickness (in)	U-Value (k ² m ² /w)	R-Value (1h ² ft ² °F/Btu)	RSI Value (0.176)
300	12	0.23	25	4.35
400	16	0.18	33	5.56
500	20	0.14	50	7.14

Hempcrete is a mixture of the Hemp stalk core (shiv) and a natural cement (hydraulic lime binder). It is critical that the shiv is thoroughly coated in lime binder to ensure the petrification of the shiv aggregate as the binder calcifies through carbon sequestration. The construction process of Hempcrete is easily learned and adapted to local building conventions, presenting an energy efficient building material culture for rural communities.

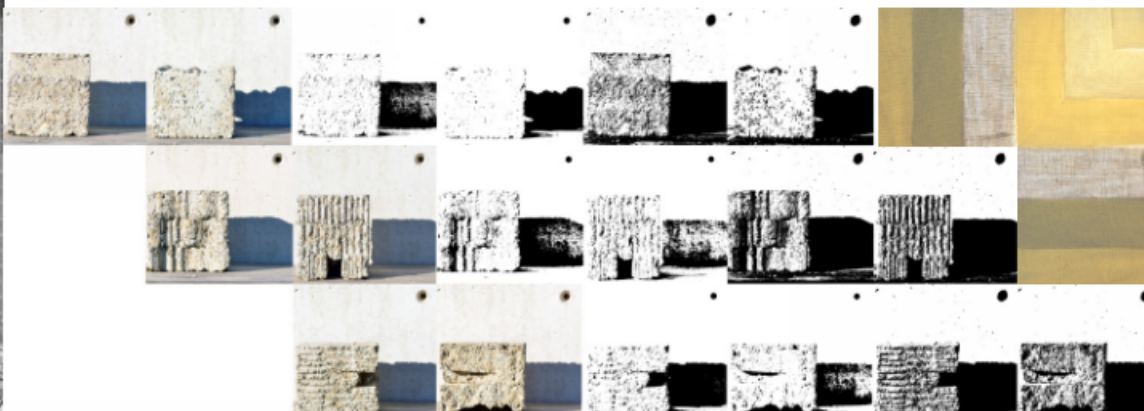
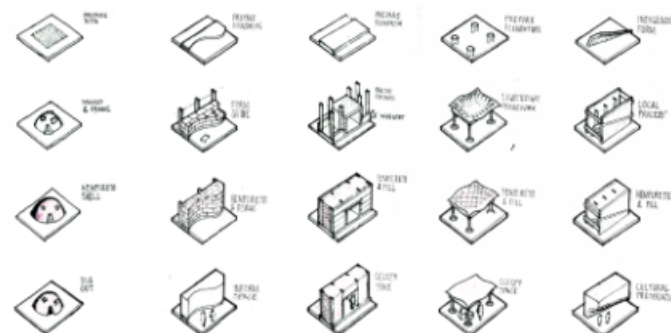

Dwelling with Hempcrete.

Modes of building and inhabiting the Hempcrete form. The texture of Hempcrete affords architecture an economy of scale, as the hemp shiv (the part) conglomerates with a hydraulic lime binder (the whole). The Hempcrete envelope is ultimately mass within space and naturally resilient to environmental process.²⁰

PROCESSED
H E M P
F I B R E

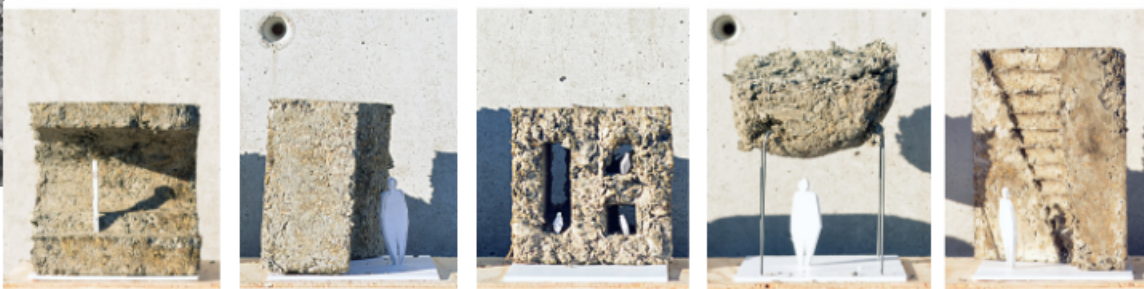

20. See Appendix A: The Barn That Raised Me, “Shiny Pebbles and Large Ripples,” 179 - 187.



1937

Re-education is needed to dispel the stigmas that have prohibited hemp production for the past 70 years. A storied past intertwined with human civilization, Hemp may reveal a new future for resilient communities to prosper.²¹

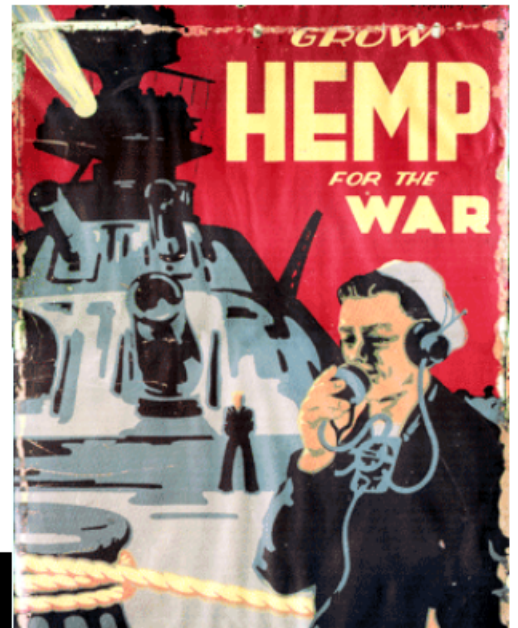

1942

HEMP IS NOT MARIJUANA!

HEMP CLASSIFICATION

Rosidae subclass

- Cannabaceae family
- Cannabis sativa L. species
- Rhizophora order
- Tricardiales order
- Linnaea sordida family
- Saxifragales order

Cannabis sativa
subspecies, industrial hemp and source of phloem fibres.

Cannabis ruderalis
subspecies, wild form of hemp.

Cannabis indica L.
subspecies, high content of tetrahydrocannabinol (THC).

Marijuana
controlled substance

Ecological Food Source
eaten organically

Industrial Hemp;
THC content < 0.03%

In all cultivars of marijuana and most cultivars of hemp there's a drug known as **delta-9 tetrahydrocannabinol (THC)** that's produced by the plant. A THC level of **0.3 percent** has been adopted in Canada as the concentration that separates non-narcotic strains from narcotic strains

Dioecious Species
requires both male and female flowering to reach maturity.

Monoecious Species
exclusively one sex of plant. Hemp is industrially produced as a female plant.

HEMP BREEDING

Male Inflorescences
forms a loose cluster of flowers at end of a central stem (rachis) with very few leaves.

Male Hemp flower

MARKS ACTIVE GROWTH PHASE AND IS PRIMARY SEED GENERATOR

Female Inflorescences
forms at the apex of the stem and flowers are borne on racemes.

Female Hemp flower

FINAL STAGE OF GROWTH AND NECESSARY FOR SEED MATURATION

Cannabis sativa

Cannabis indica L.

Cannabis ruderalis

Very High Density Fiber Crop

Moderate Density Dual Purpose Crop

Moderate Density Early Maturing Oilseed Crop

Low Density Oilseed Crop

Low Density Narcotic Crop

21. See Appendix A: The Barn That Raised Me, "Agro-Architecture_Design," 99-111.

Hemp for a Resilient Rural Economy

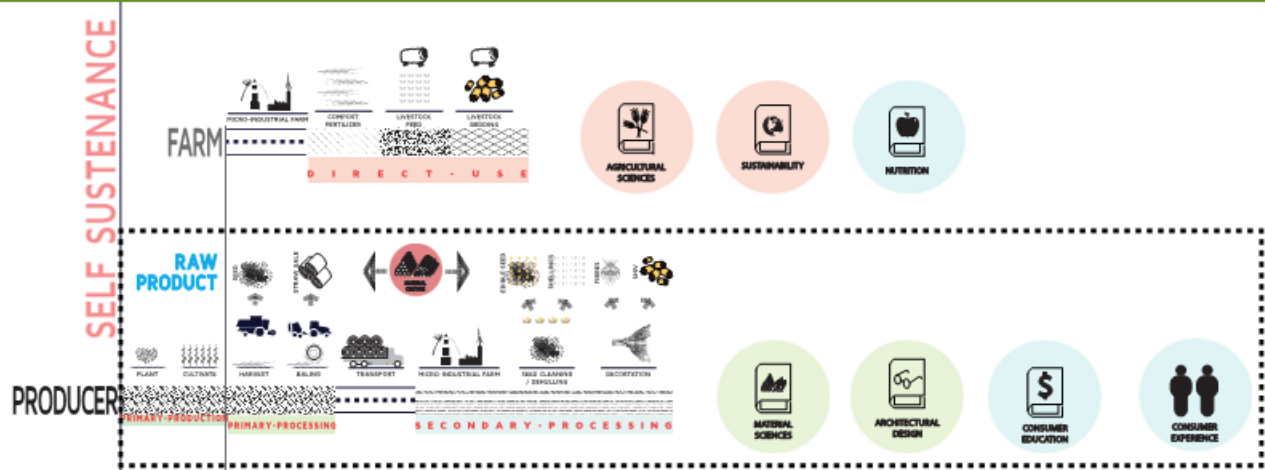

PRIVATE How Hemp Helps Local Agricultural Producers



Value-Add opportunity for the rural producer to develop new industries within the prairie landscape with industrial Hemp production.²²

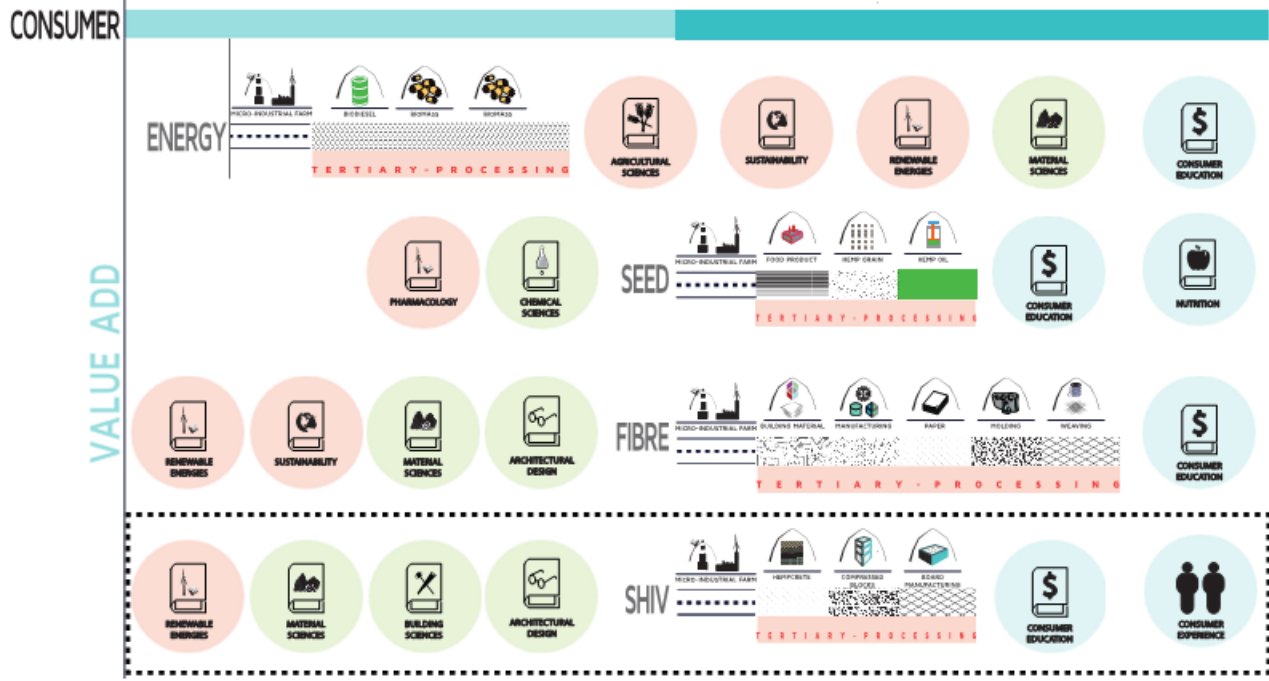

22. See Appendix A: The Barn That Raised Me, "Section 3: Radical Rationalization," 157-165.

The Industrial Hempcrete Building

Building New Industry.

Industrial Buildings for a sustainable agricultural process.²³

JustBiofibre Structural Solutions

Super SSR Hempcrete Block
 40 + MPa (26 + 33 n/mm²) (compressive rating)
 .70 gm/m²/mmhg (air permeability)
 .23 gm/m²/mmhg (vapour permeability)
 421 mj/m² (embodied energy)
 -17.6 kg/m²

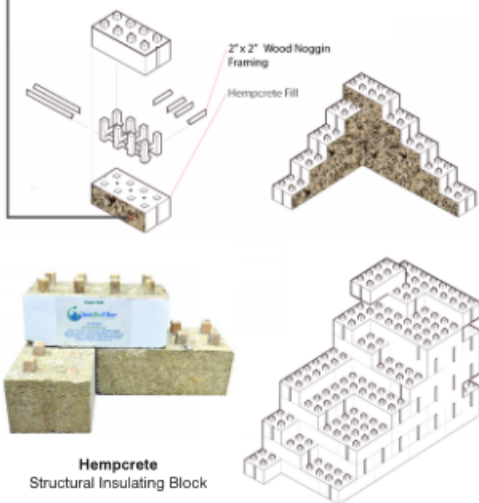

WALKING BESIDE

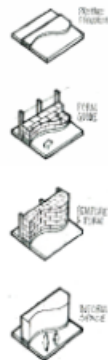

Prefinished Metal Sheathing
 2" x 2" Horizontal and Vertical Wood
 Battens, maintain 2" airspace
 T&G Wood Fibre Sarking Board
 2x6 Engineered Wood Frame Truss
 12" Hempcrete Ceiling Infill, R25
 3/4" Wood Wool Board

Hempcrete Ceiling
 Spray Application

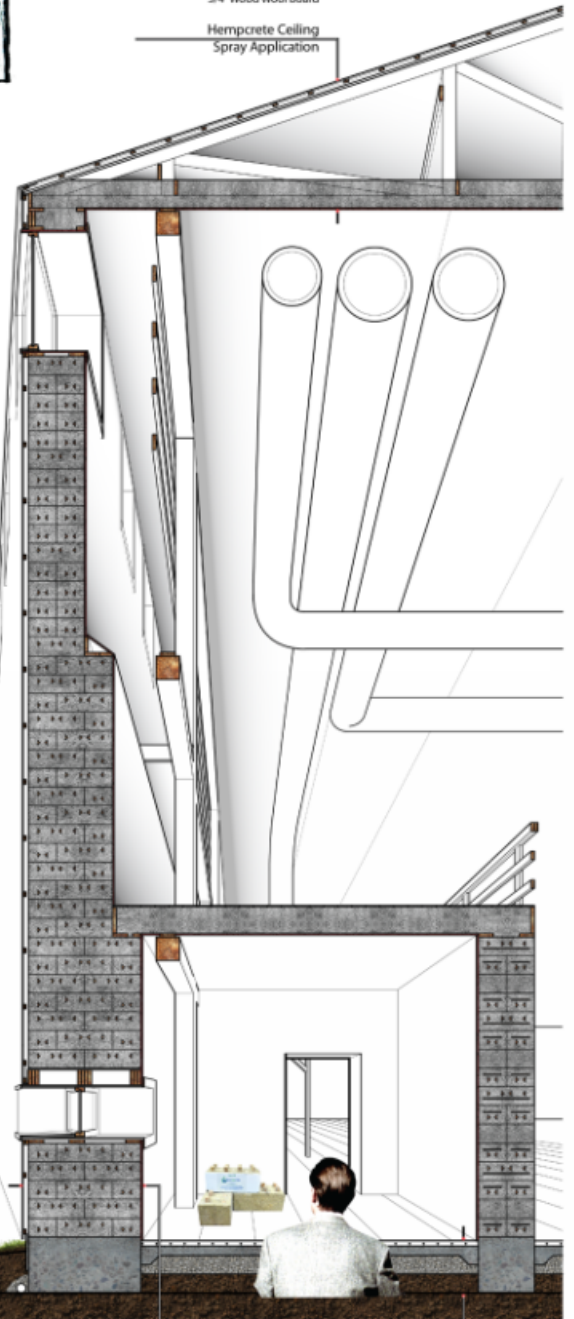

Structural Hempcrete Block Wall

Floating Concrete Slab

Prefinished Metal Sheathing
 2" x 2" Horizontal and Vertical Wood Battens
 Lime Cement Render Base Coat
 16" x 8" x 21" Super SSR Hempcrete Block
 3/4" Wood Wool Board

Tile Floor
 1" Lime Cement Mortar Cover
 1/2" In-floor Heating Conduit
 6" Ribbed Concrete Floor Slab w/ Industrial Hardener
 6" Compacted Gravel
 6 mil PolyVapour Barrier
 Undisturbed Earth

23. See Appendix B: The Barn I'd Raise, "Work_Decortication Facility," 304-305.

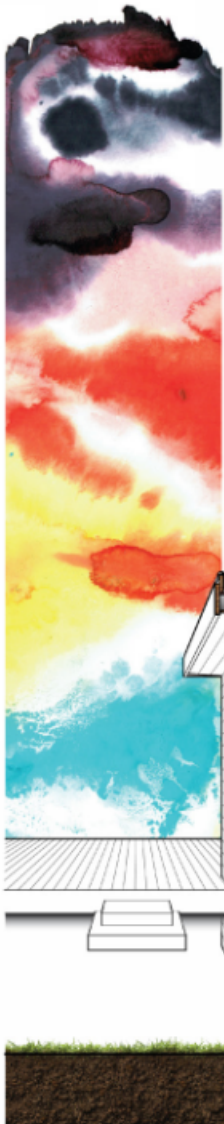

Greenroof

- 4" min. Green Roof Buildup
- Root Barrier
- Drainage Board
- SBS Roofing Membrane
- 1" T&G Wood Fibre Sarking Board
- 1" x 2" Horizontal and Vertical Wood Battens, maintain 2" airspace
- 16" Engineered Open Web Wood Joist @ 24" o.c.
- 12" Hempcrete Ceiling Fill, **R25**
- 2" x 2" SPF Wood Noggins
- 3/4" Wood Wool Board

Hempcrete Ceiling
SIP

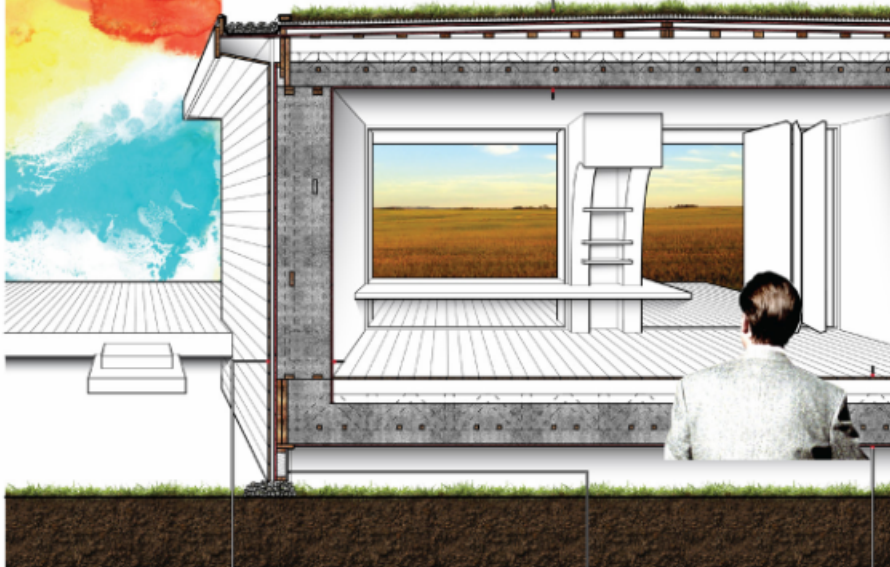
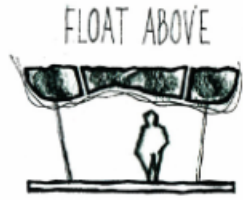

Hempcrete Wall
SIP

- Horizontal Tight Fitting Shiplap Wood Cladding
- 1" x 2" Vertical Battens, maintain 1" airspace
- 3/4" Wood Wool Board, both sides
- 16" Hempcrete Wall Fill, **R33, .458 MPa**
- Shear Wall - Double 2x6 Wood Framing @ 16" o.c.
- w/ 3/4" OSB shearplate
- 3/4" Wood Wool Board



Hempcrete Floor
SIP

- 3/4" Hardwood Plank Flooring
- 1" x 6" Diagonal Wood Planking
- 16" Engineered Open Web Wood Joist @ 24" o.c.
- 12" Hempcrete Floor Infill, **R25**
- 2" x 2" SPF Wood Noggins
- 3/4" Wood Wool Board

Foundation & Skirting Wall

- Engineered Steel Screw Pile
- 12'-0" min. depth
- 3/4" Wood Wool Board, both sides
- 2x6 Stud Wall @ 16" o.c.
- R-20 Hempwool Batt Insulation
- Cleaned Crushed Gravel piled 3" above base of Skirting wall

The Residential Hempcrete Building

Building New Beginnings.

Factory Built Homes Shipped directly to your Farmstead.²⁴



Hempcrete - Hand Mixed

24. See Appendix B: The Barn I'd Raise, "Section 2: The Seed Building," 256-257.

The Sustainable Hempcrete Vernacular

Growing a New Agricultural Building Typology.

Hempcrete assimilates conventional building practice into re-imagined and personalized homes.²⁵



Hempcrete Exterior Wall - Plaster



Hempcrete Wall - Cast-in-Place

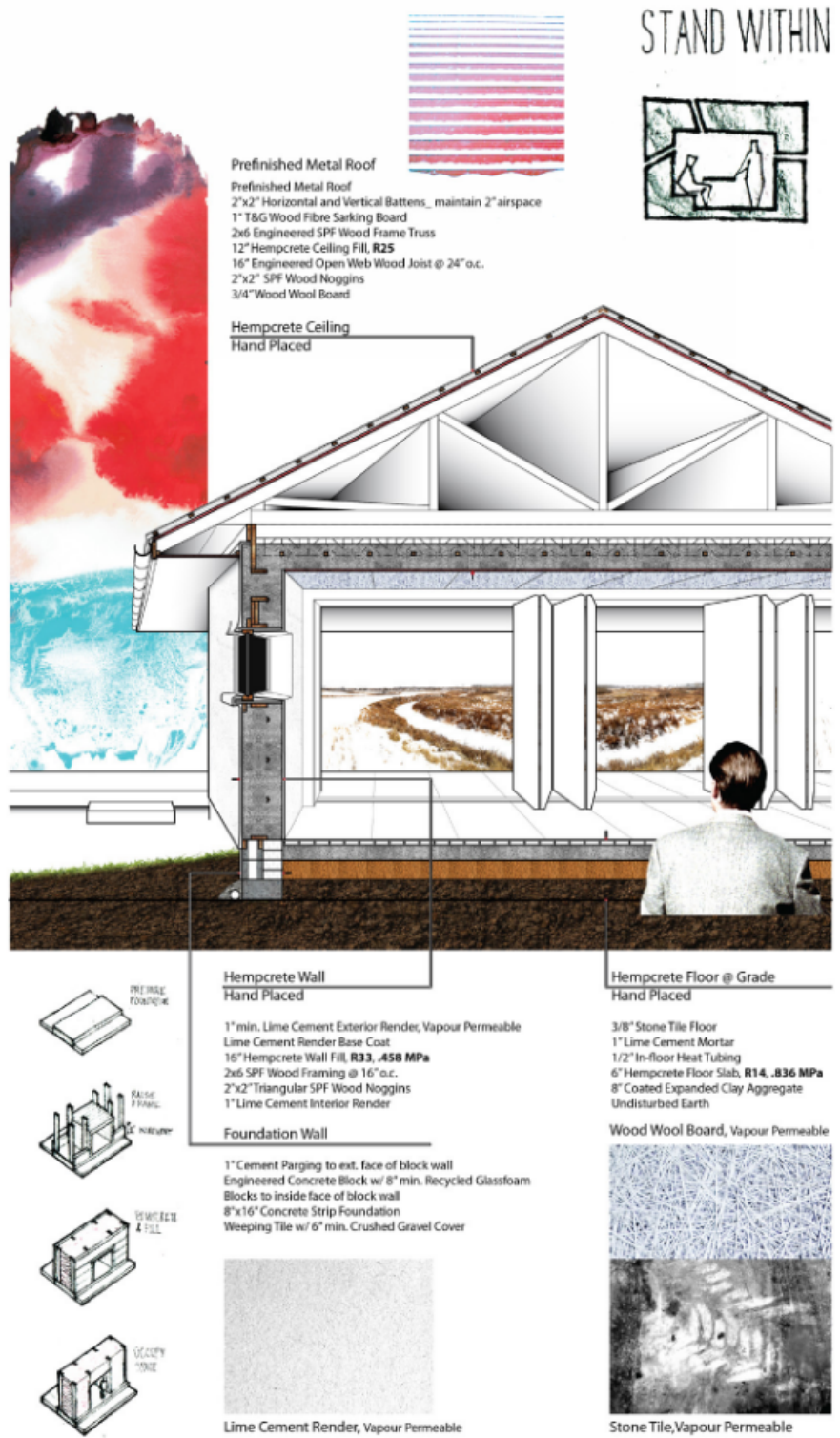

25. See Appendix B: The Barn I'd Raise, "Section 3: Agro-Architecture," 280-281.

RESIDUAL FORM

- Prefinished Metal Roof
- 2" x 2" Horizontal and Vertical Wood Battens, maintain 2" airspace
- T&G Wood Fibre Sarking Board (vapour permeable)
- 2x6 Wood Frame Truss
- 12" Hempcrete Ceiling Fill, **R25**
- 12" Engineered TGI Wood Rafter @ 24" o.c.
- 3/4" Wood Wool Board, Permanent Shuttering

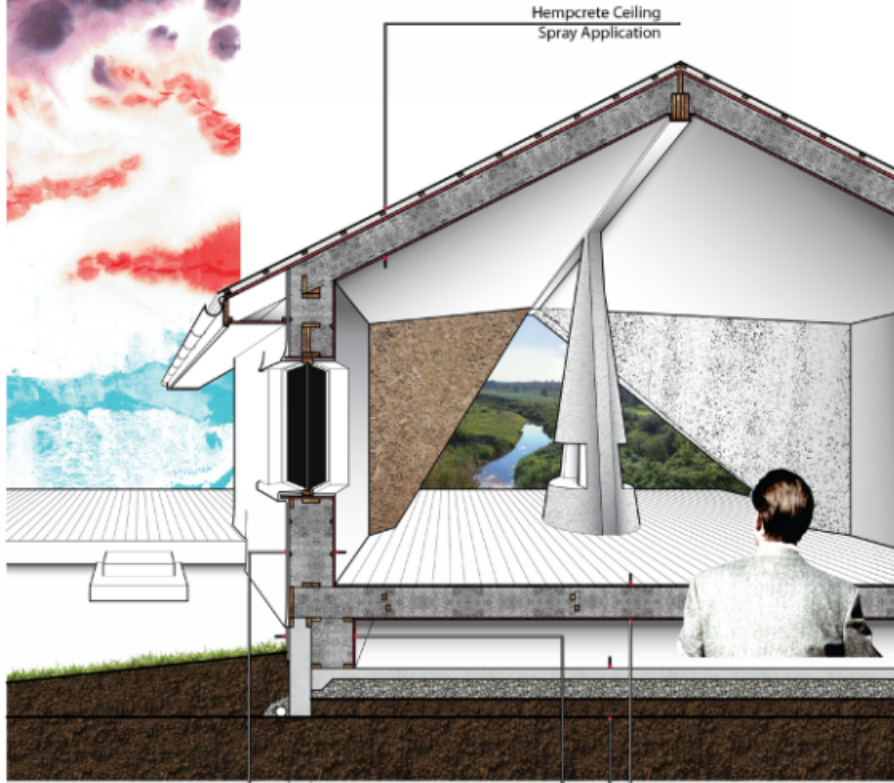
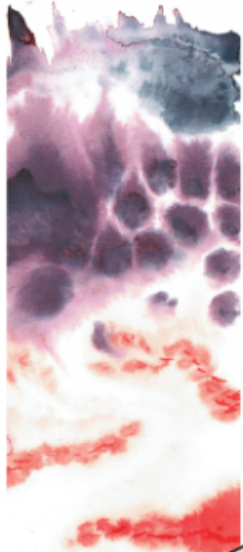

The Resilient Hempcrete Home

Building Sustainable Lifestyles.

Sustainable Communities demand a commitment to a lifestyle and future for the next generation.²⁶

- INDIGENOUS CURVE
- LOCAL BRICKS
- HEMPCRETE FILL
- CULTURAL REINFORCEMENT

Hempcrete Wall
Spray Application

- 1" min. Lime Cement Exterior Render
- Lime Cement Render Base Coat
- 16" Hempcrete Wall Fill, **R33, 458 MPa**
- 2x6 SPF Wood Framing @ 16" o.c.
- 2"x2" Triangular SPF Wood Noggins, both sides

Foundation Wall

- 1" Cement Parging to ext. face of block wall
- 8" Reinforced Concrete Foundation Wall
- 8" Floating Concrete Piles, 8'-0" min. depth
- SBS Membrane, liquid applied
- 8"x16" Concrete Strip Foundation
- 16" Hempcrete Wall Fill, **R33, 458 MPa**
- 2x6 Wood Framing @ 16" o.c.
- 3/4" Wood Wool Board
- Weeping Tile w/ 6" min. Crushed Gravel Cover

Plenum Hempcrete Floor
Spray Application

- 3/4" Hardwood Plank Flooring
- 2x12 SPF Wood Floor Joists @ 16" o.c. w/
- 2" x 2" Diagonal SPF Wood Bridging
- 12" Hempcrete Floor Infill, **R25**
- 3/4" Wood Wool Board
- Heated Airspace

Reinforced Floating Concrete Slab

- 4" Concrete Slab
- 6 mil Poly Vapour Barrier
- 2" Recycled Foam Glass Block
- 6" Compacted Gravel
- Undisturbed Earth

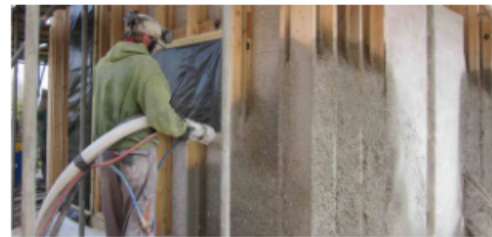

Hempcrete Wall -Spray Application



Hempcrete Interior Wall - Plaster

26. See Appendix B: The Barn I'd Raise, "Play_The Community Hall," 320-321.

Modern Hempcrete Buildings

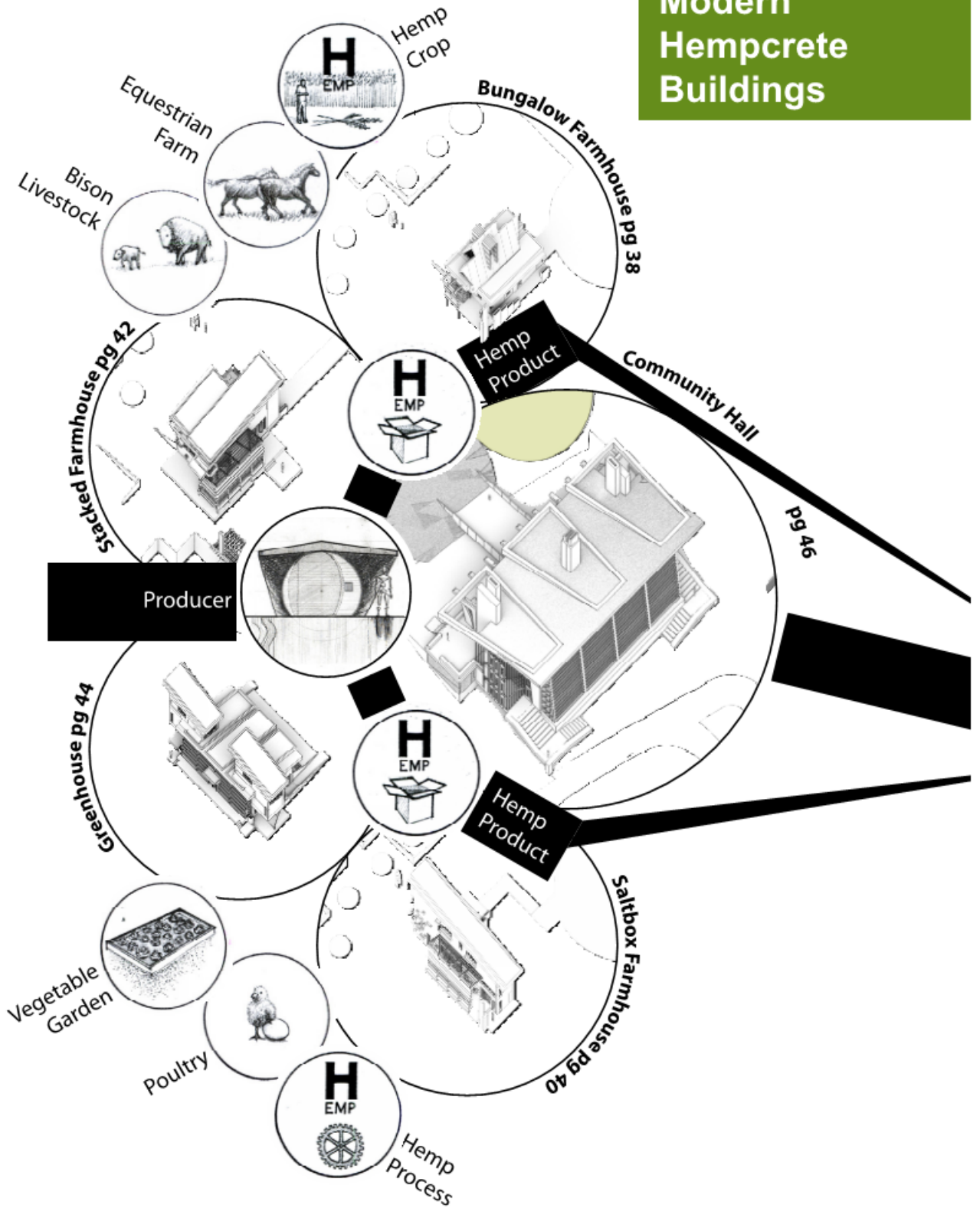

Contents

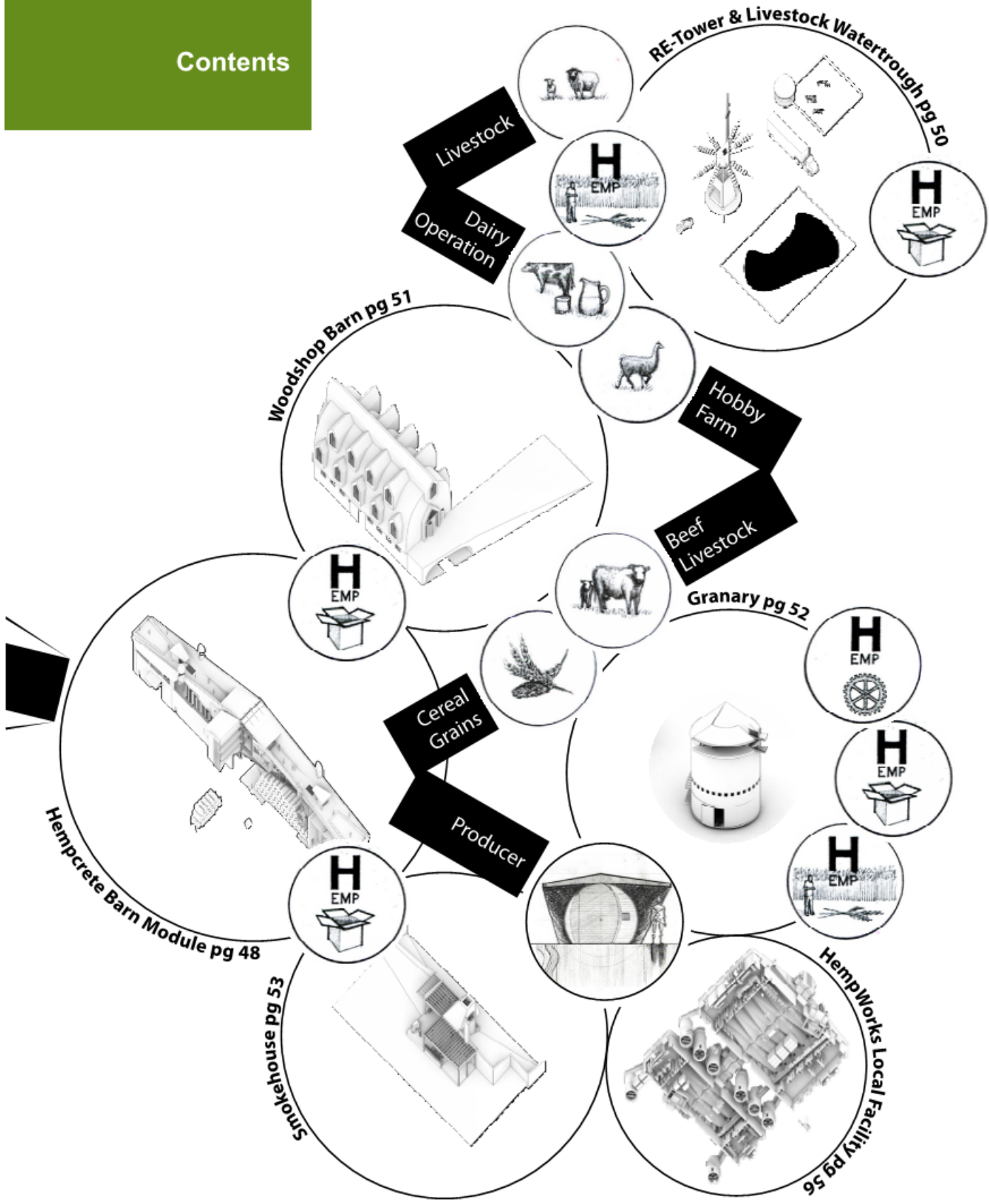

This residence is intended for budding rural producer and family. Developed from a 5m x 5m grid, the rooms are configurative, programmed to reflect the rural process. The Bungalow Farmhouse features a 2m x 5m greenhouse at its South face to create interior atmosphere and a living wall for resilient food production.²⁷

Bungalow Farmhouse

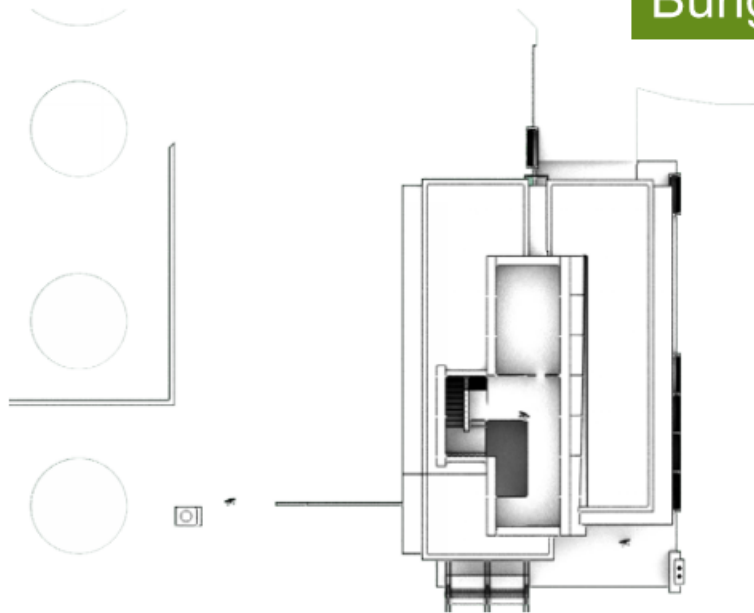

Second Floor Plan

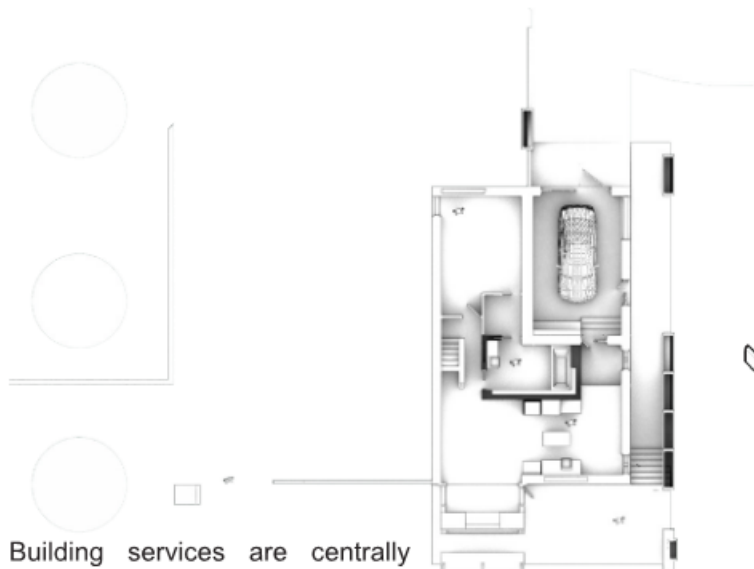
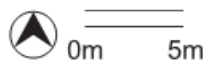

Main Floor Plan

Building services are centrally located and consist of a full bath accessed from the stairwell hall, or, through the master bedrooms walk-in-closet.

Occupants:	3 - 4
Floor Area:	125 m²
Hempcrete Building Envelope:	225 m³
Estimated Cost of Hempcrete:	\$ 26390

Bungalow Homecoming.

A heated garage, or studio, faces North and the residential work programming becomes the entrance to the home. Entering onto a sunken porch, procession through the home is oriented to the sun's path and begins in the kitchen/dining room, through the greenhouse/living room, and into the master bedroom.

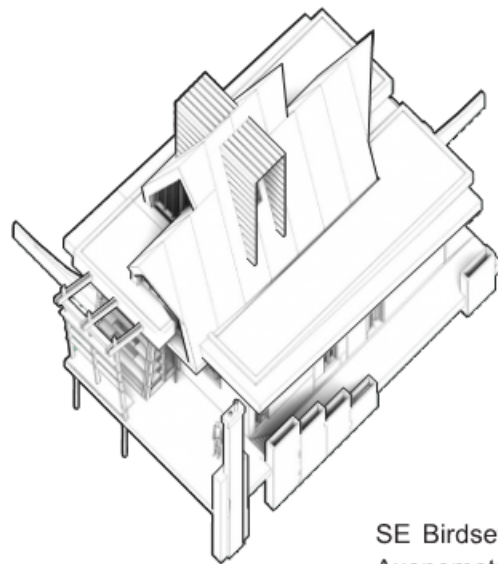

SE Birdseye Axonometric

27. See Appendix B: The Barn I'd Raise, "The Bungalow Farmhouse," 282-285.

The second storey addition to the stereotypical bungalow is necessary to provide a minimal footprint and economically accommodate a new family. Fashioned after the sod houses of immigrant prairie settlers, the steeply pitched roof concentrates heat at the peak of the interior space - heat which is transferred into the continuous Hempcrete envelope via thermal massing.

Mechanical services are hidden under the living space in a plenum floor.

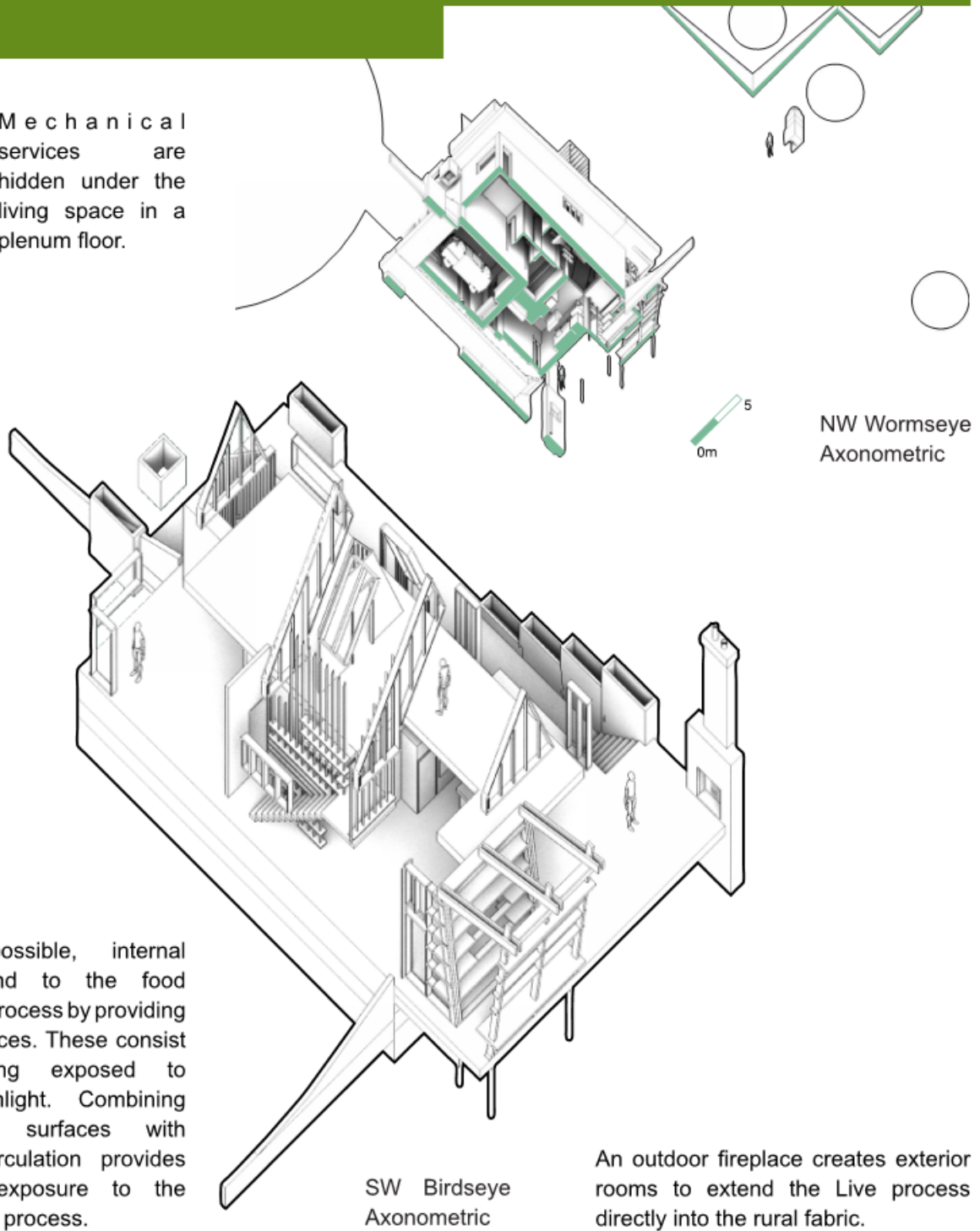

Where possible, internal rooms lend to the food resiliency process by providing living surfaces. These consist of shelving exposed to direct sunlight. Combining productive surfaces with internal circulation provides constant exposure to the agricultural process.

An outdoor fireplace creates exterior rooms to extend the Live process directly into the rural fabric.

The Saltbox is designed for established producers that seek a more spatially accommodating farmhouse. A rectangular volume oriented West by East allows for thermal heat massing, capturing natural sunlight throughout the day. An exterior deck extends the Live/Work/Play area into the prairie landscape, capped by an exterior fireplace that looks onto a grain field vista.²⁸

The Saltbox Farmhouse

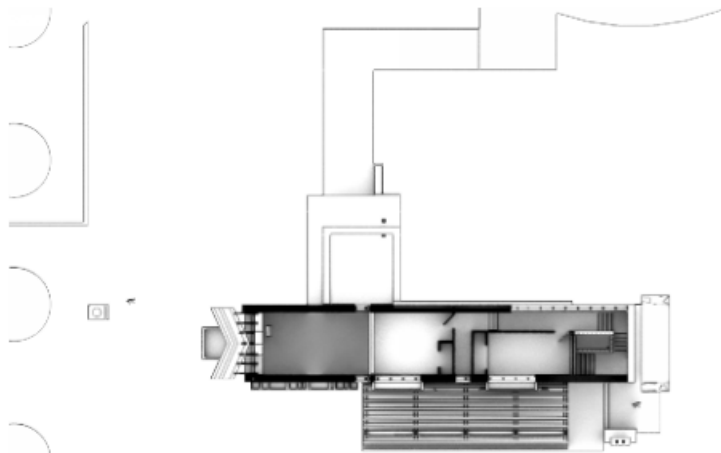

Second Floor Plan

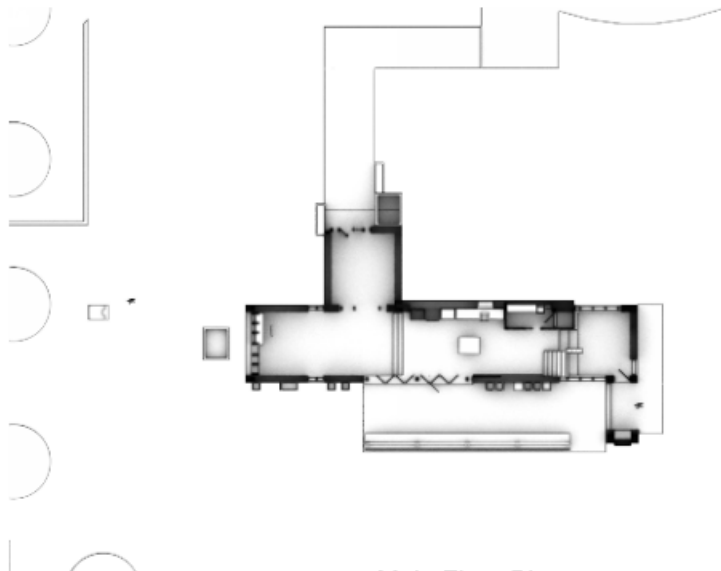

Main Floor Plan

Occupants: **3 - 4**

Floor Area: **150 m²**

Hempcrete
Building Envelope: **315 m³**

Estimated Cost of
Hempcrete: **\$ 36950**

Saltbox Homecoming.

With no attached garage, the Saltbox is focused on living in the rural landscape for the appreciation of its natural beauty. Bedrooms are lifted to the second storey to provide scenic panoramas to the occupants, create a heat stack for energy conservation.

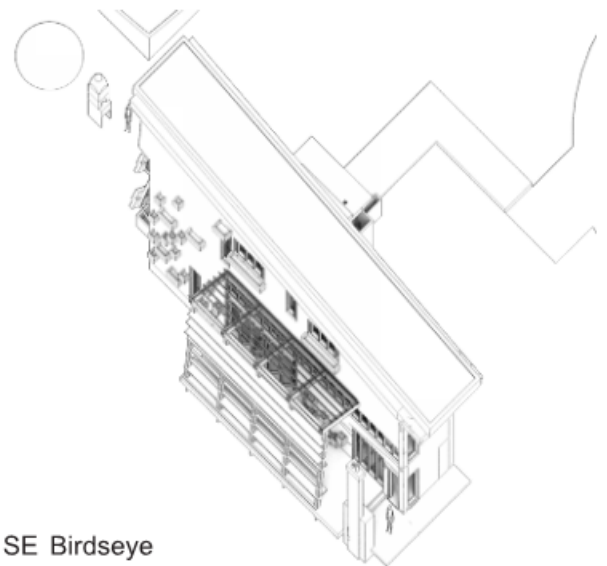

SE Birdseye
Axonometric

28. See Appendix B: The Barn I'd Raise, "The Saltbox Farmhouse," 286-289.

Visitors approach the Saltbox from the North and are greeted by a single storey porch, as the two storey house rises behind. The porch is essential to the interface between a formal interior and rugged exterior. At its West end, the three storey volume denotes the living room and interior greenhouse wall/bookshelf. Moving East from the living room, the kitchen and bathroom are aligned to the North wall to allow for a continuous interior volume.

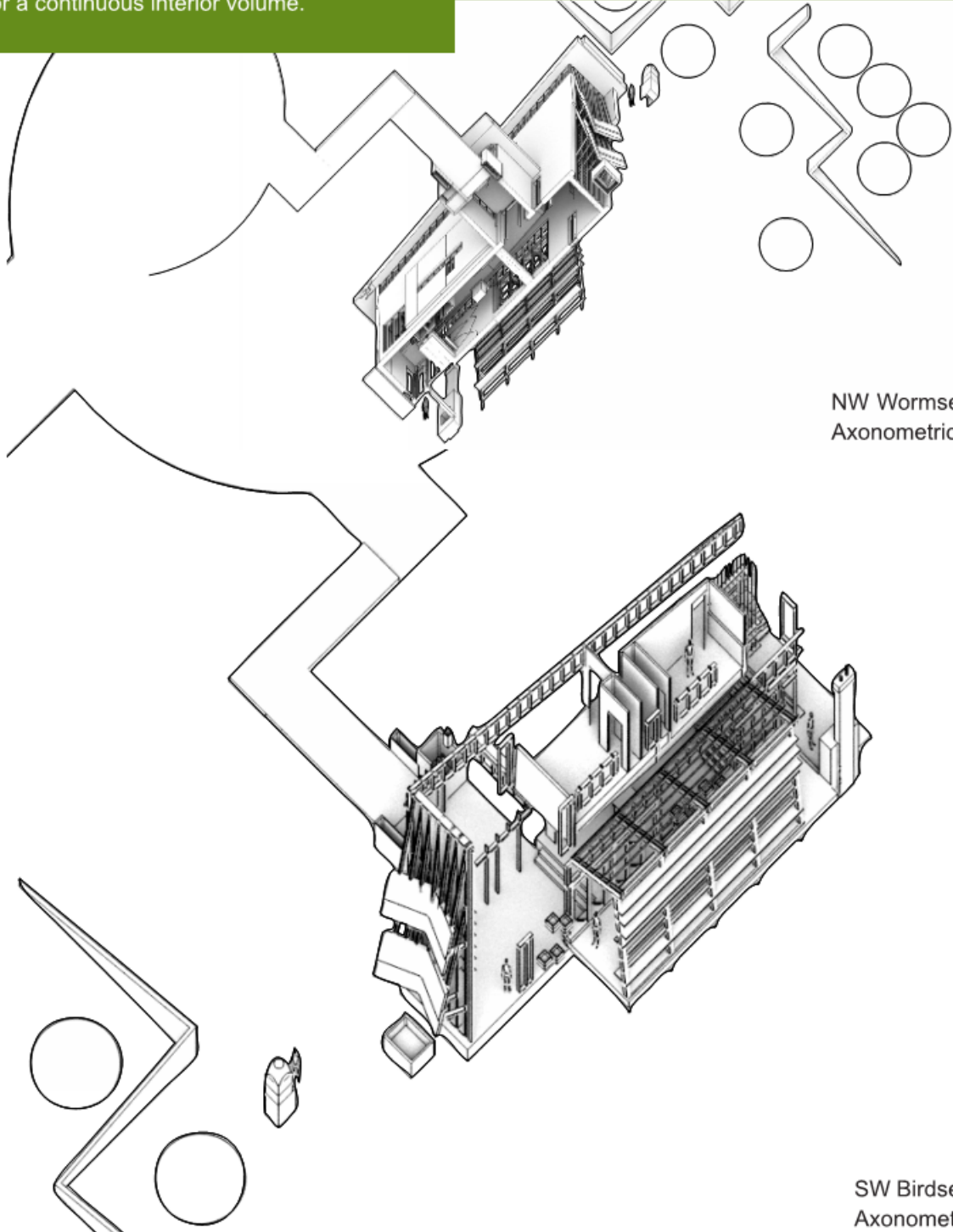

Stacked Farmhouse was designed to accommodate an expanding family household with an established agricultural process. Designed to be heated using passive solar, the house also features a large greenroof for greywater collection. A stacked program massing reduces the footprint and orients procession. Large openings are placed in the East wall to brighten the producers morning routine.²⁹

The Stacked Farmhouse

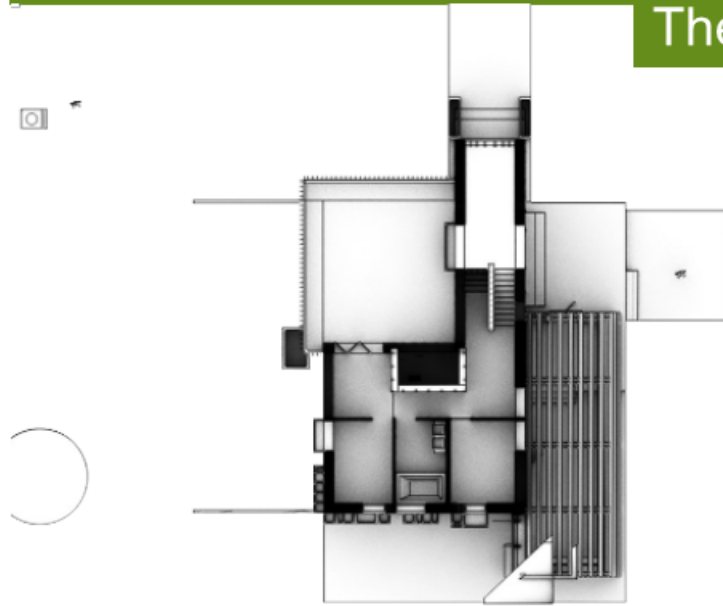

Second Floor Plan

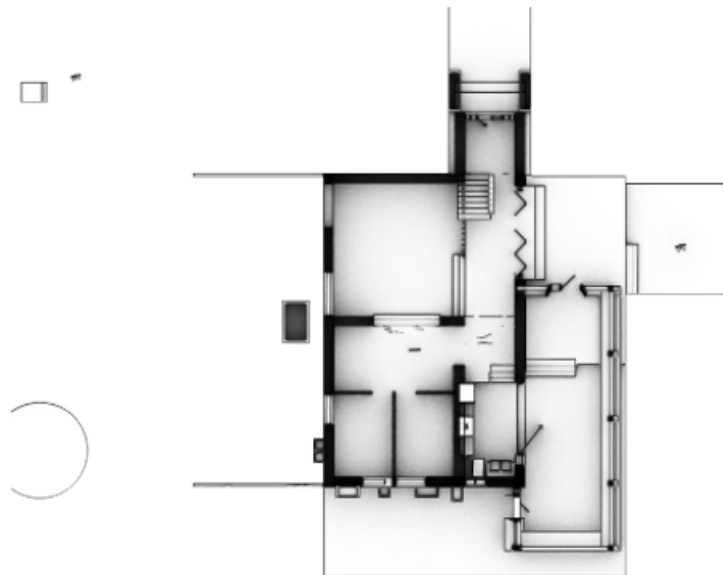
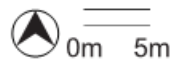

Main Floor Plan

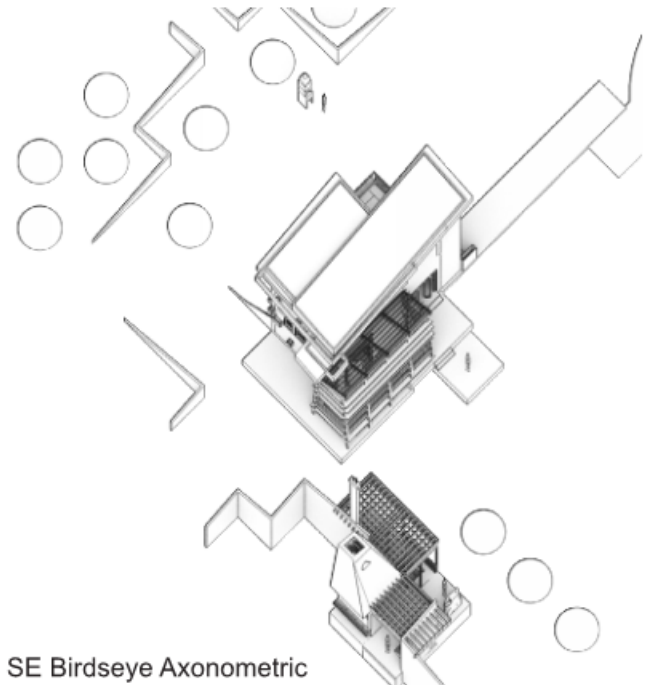

SE Birdseye Axonometric

Occupants: **6-8**

Floor Area: **150 m²**

Hempcrete
Building Envelope: **360 m³**

Estimated Cost of
Hempcrete: **\$ 42230**

29. See Appendix B: The Barn I'd Raise, "The Stacked Farmhouse," 290-293.

A two storey residence that features a Southeast facing kitchen/greenhouse, Stacked house places bedrooms, kitchen and bath at the Southern extent of the house to utilize natural day lighting. Building form expresses the 5m x 5m programming and creates the second storey patio facing Northwest to view the sunset. A studio/office sits above the porch entrance facing North, expressing a high ceiling point used to prevent overheating in the bedrooms.

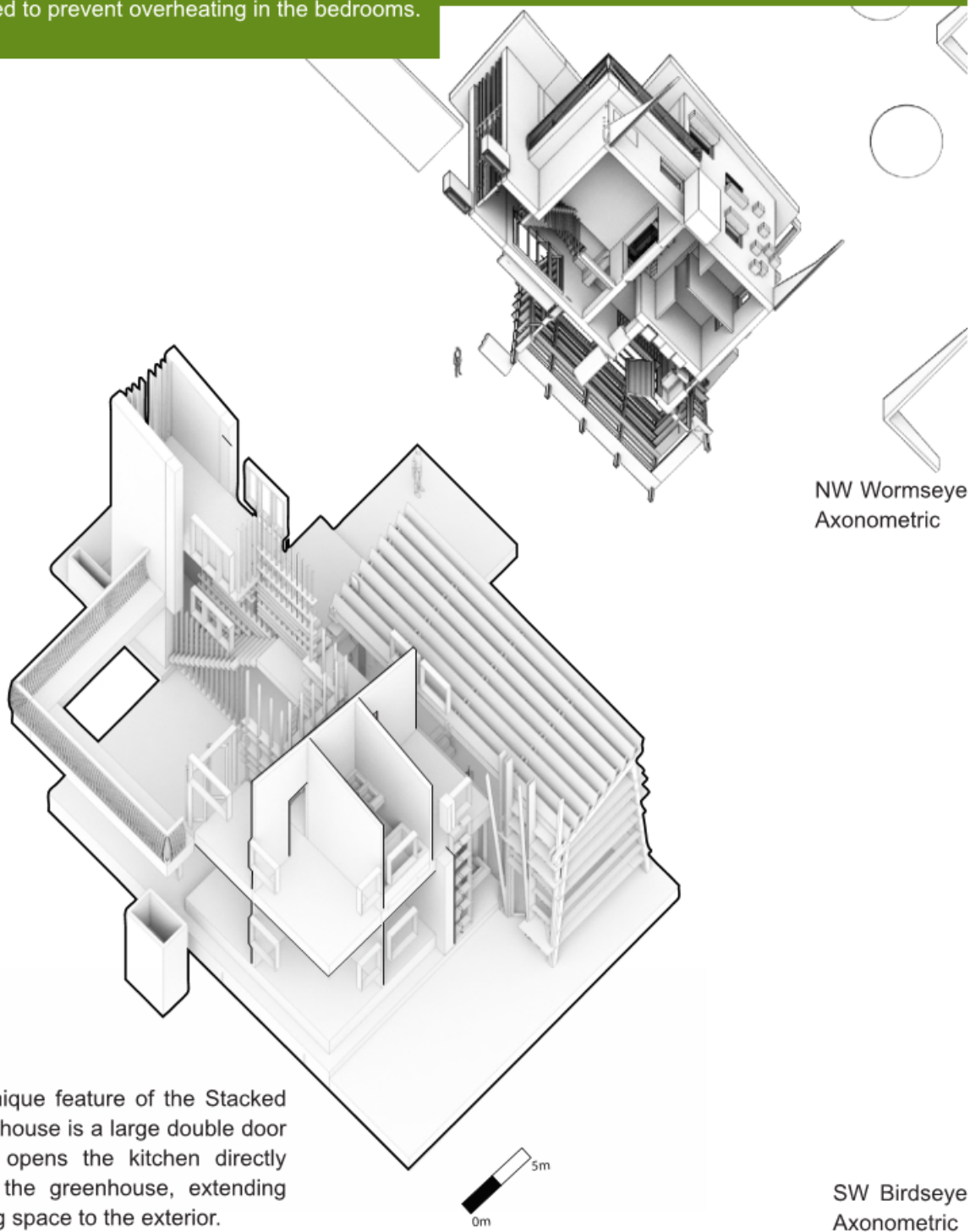

A unique feature of the Stacked farmhouse is a large double door that opens the kitchen directly into the greenhouse, extending living space to the exterior.

The Greenhouse is programmed for the social and cultural process of food production. As two double-occupant residences are set above the South wall, they share the Greenhouse, a symmetrical assemblage of kitchen, dining hall, sunken living room, aquaculture tank, and living wall.³⁰

The Greenhouse

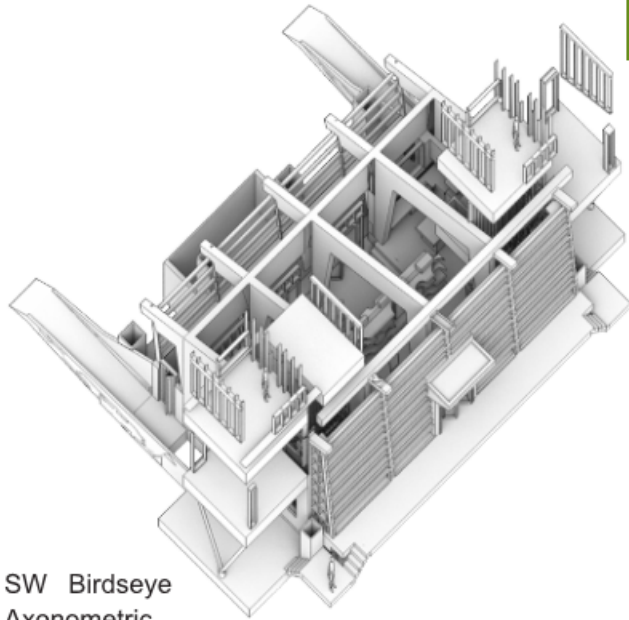

SW Birdseye
Axonometric

Occupants: **3 - 4**

Floor Area: **200 m²**

Hempcrete
Building Envelope: **450 m³**

Estimated Cost of
Hempcrete: **\$ 52780**

The Greenhouse utilizes a flat sloped roof to collect runoff for an integrated greywater system. The concept of the greenhouse is to allow producers year round cultivation of organic fruits and aquaculture. By allowing for two individuals to learn from each others dwelling lifestyle.

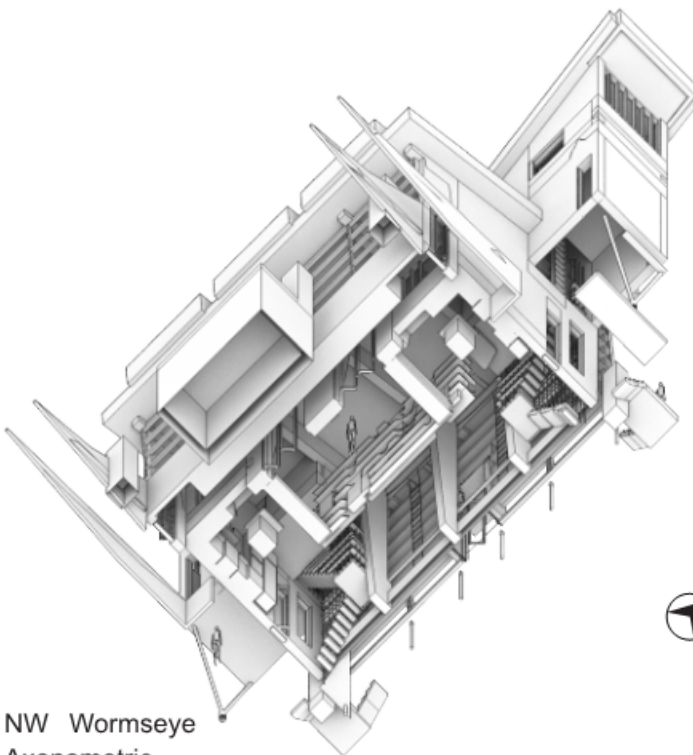

NW Wormseye
Axonometric

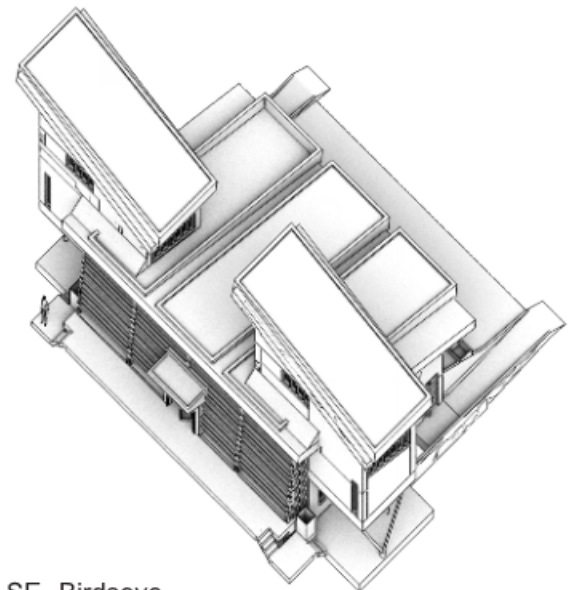

SE Birdseye
Axonometric



30. See Appendix B: The Barn I'd Raise, "Food_Kitchen Greenhouse ," 260-263.

The Configured Farmhouse is the realization that family farms do grow, and over time, the farmhouse must grow with it. The fully developed farmhouse can accommodate multiple families and employees that each assist in the operation of a generational family farm. As such, this farmhouse is the assemblage of the Greenhouse, Bungalow, Saltbox, and Stacked farmhouses - homes within homes.³¹

Configured Farmhouse

An essential criticism of the industrial agricultural process is that it removes Play from a Rural Lifestyle. As producers build their operation, Play structures such as the Smokehouse afford an opportunity to truly decompress within the rural landscape.

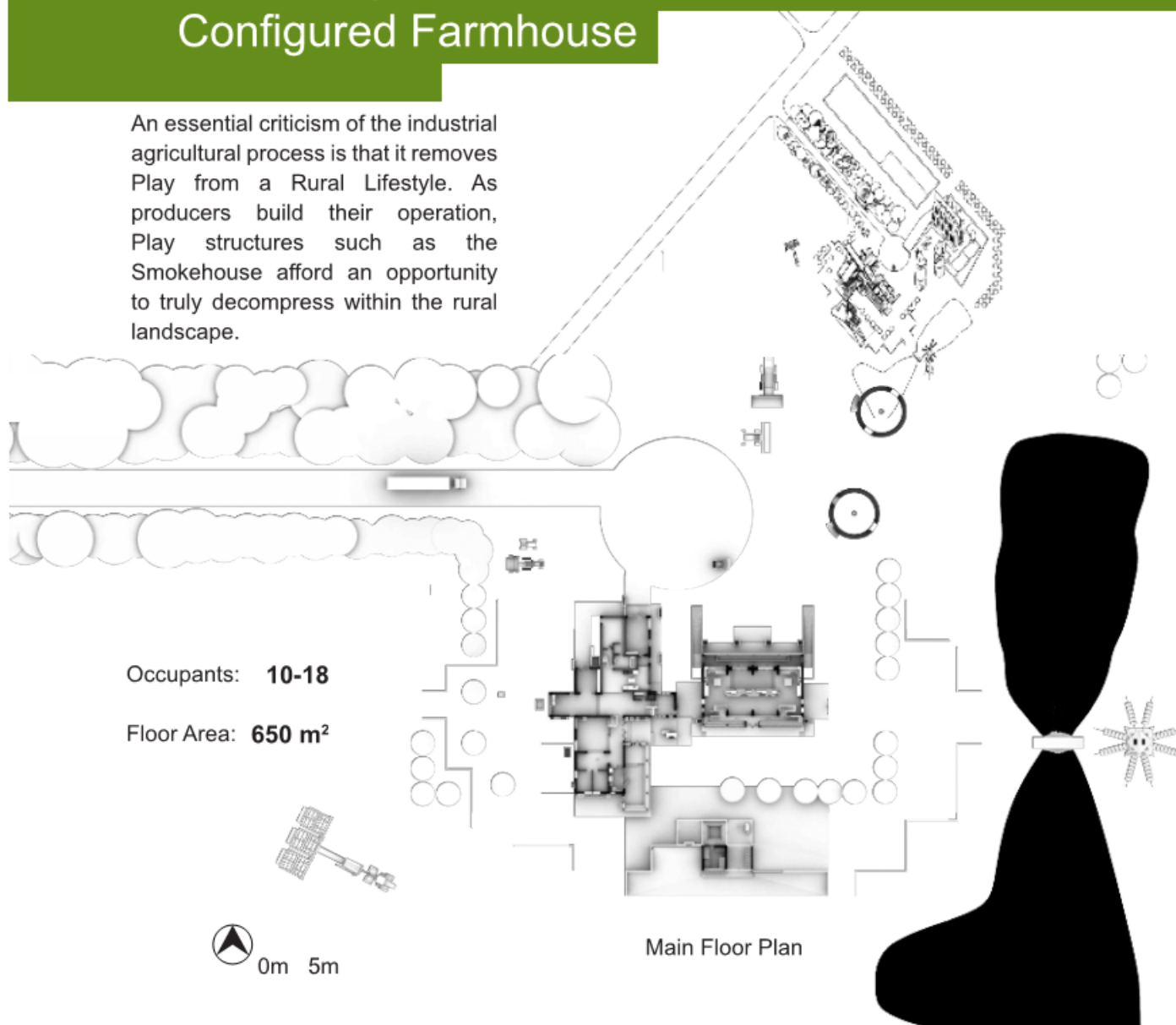

31. See Appendix B: The Barn I'd Raise, "Live_The Configured Farmhouse," 296-303.

The built form of the Community Hall is non-intrusive upon the prairie landscape, dug into a steep embankment that overlooks an intermittent river to the East. Visitors approach from the West, passing a Hempcrete Barn Module, RE-Towers and an assortment of Hempcrete farmhouses which express the aesthetic beauty of a sustainable rural community.³²

Community Hall

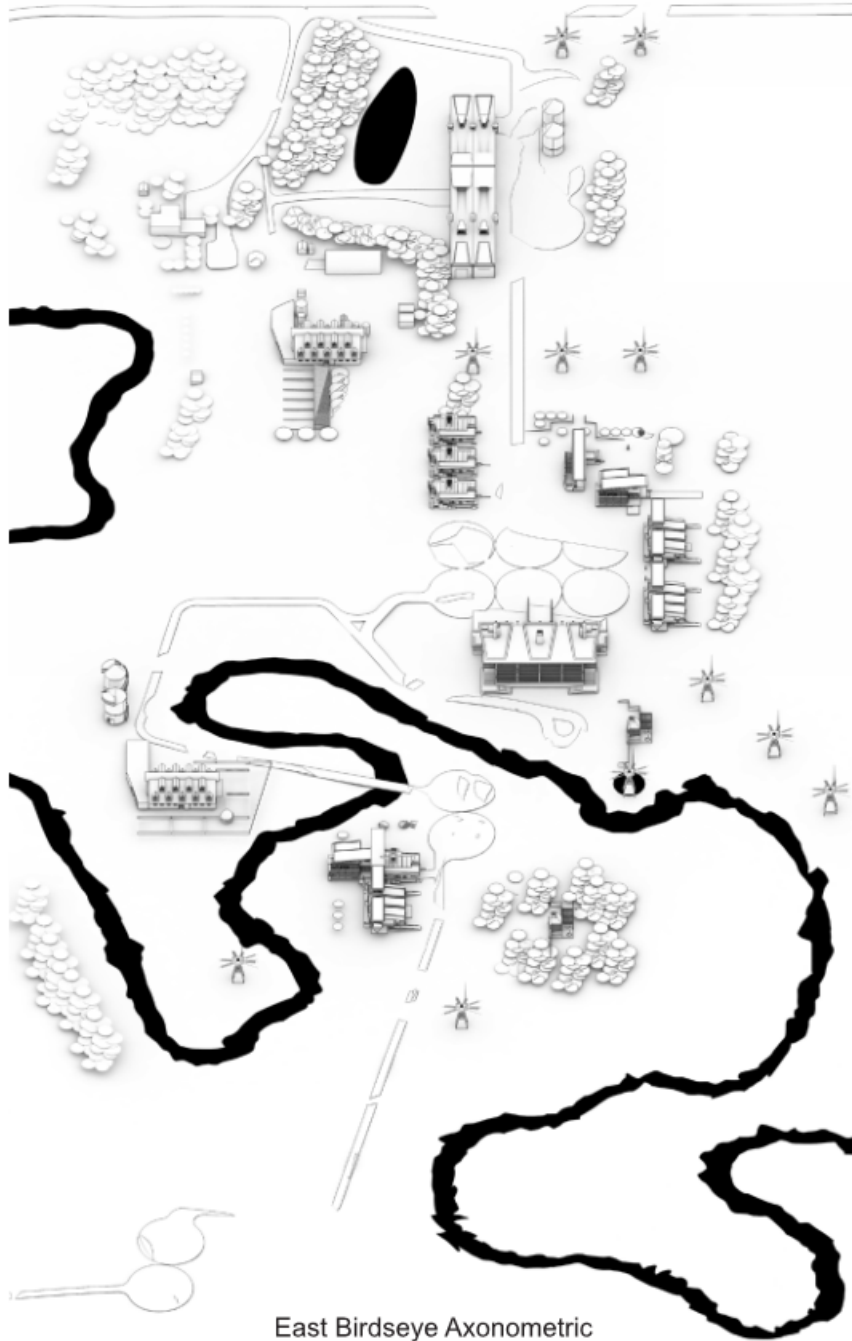

Occupants: **20-320**

Floor Area: **1500 m²**

Hempcrete
Building Envelope: **900 m³**

Estimated Cost of
Hempcrete: **\$ 105570**

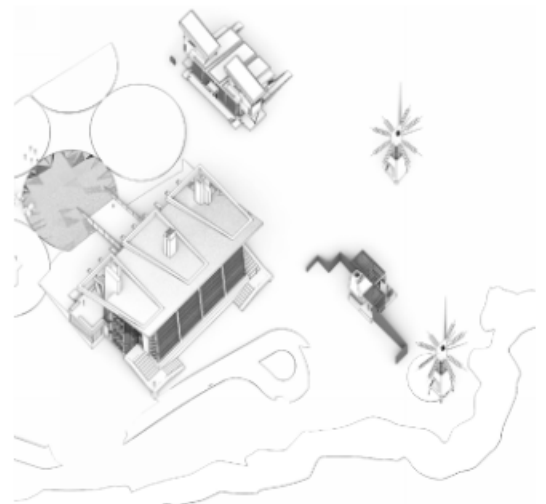

The Community Hall is intended as the commercial interface between the urban consumer and the rural producer. As such, programs that reflect a resilient rural process, like the RE-Tower, Smokehouse, and Greenhouse complete the experience of a rural Live/Work/Play lifestyle. Provision of temporary residence at the Community Hall reveals the direct immersion of consumer in rural process.

32. See Appendix B: The Barn I'd Raise, "Play_The Community Hall," 321-331.

The Community Hall is a Value-Add generational farm process wherein a family manages a social and cultural venue for the rural and urban community. Programmatically, the hall functions as local farmer's market, dance and music hall, catered restaurant, and town hall. As rural density is sparse, multiple consumer programs that focus attention onto the aesthetic beauty of the prairie landscape is critical to catalyzing the consumers experience.³³

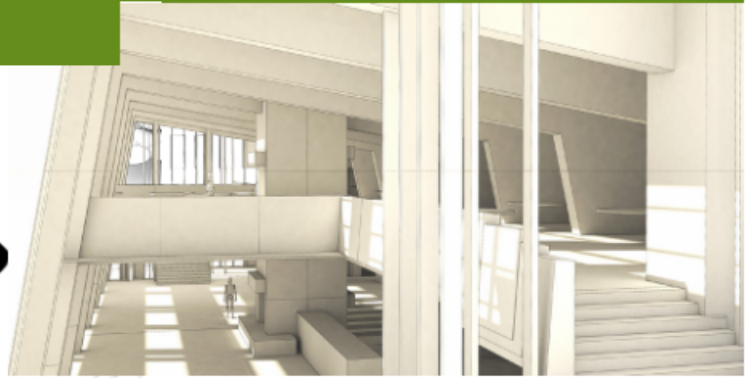

Interior Perspective of the Community Hall

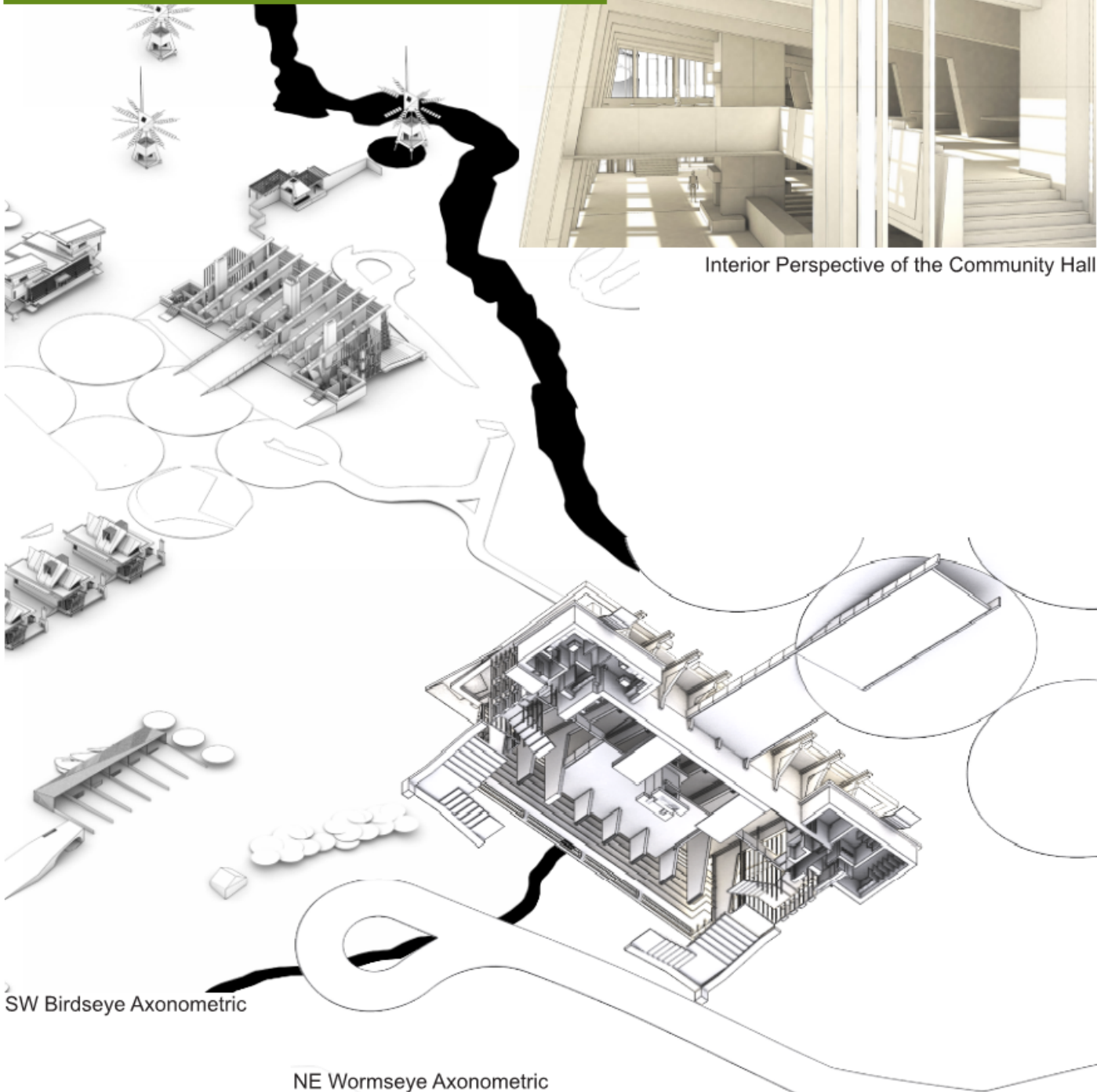

33. See Appendix B: The Barn I'd Raise, "Conclusion," 331-337.

The Hempcrete Barn

An industrially scaled barn suitable for any agricultural, industrial, or commercial process, the Barn Module uses economical and sustainable building materials in coordination with Low-Energy building principles to value-add the generational farming process.³⁴

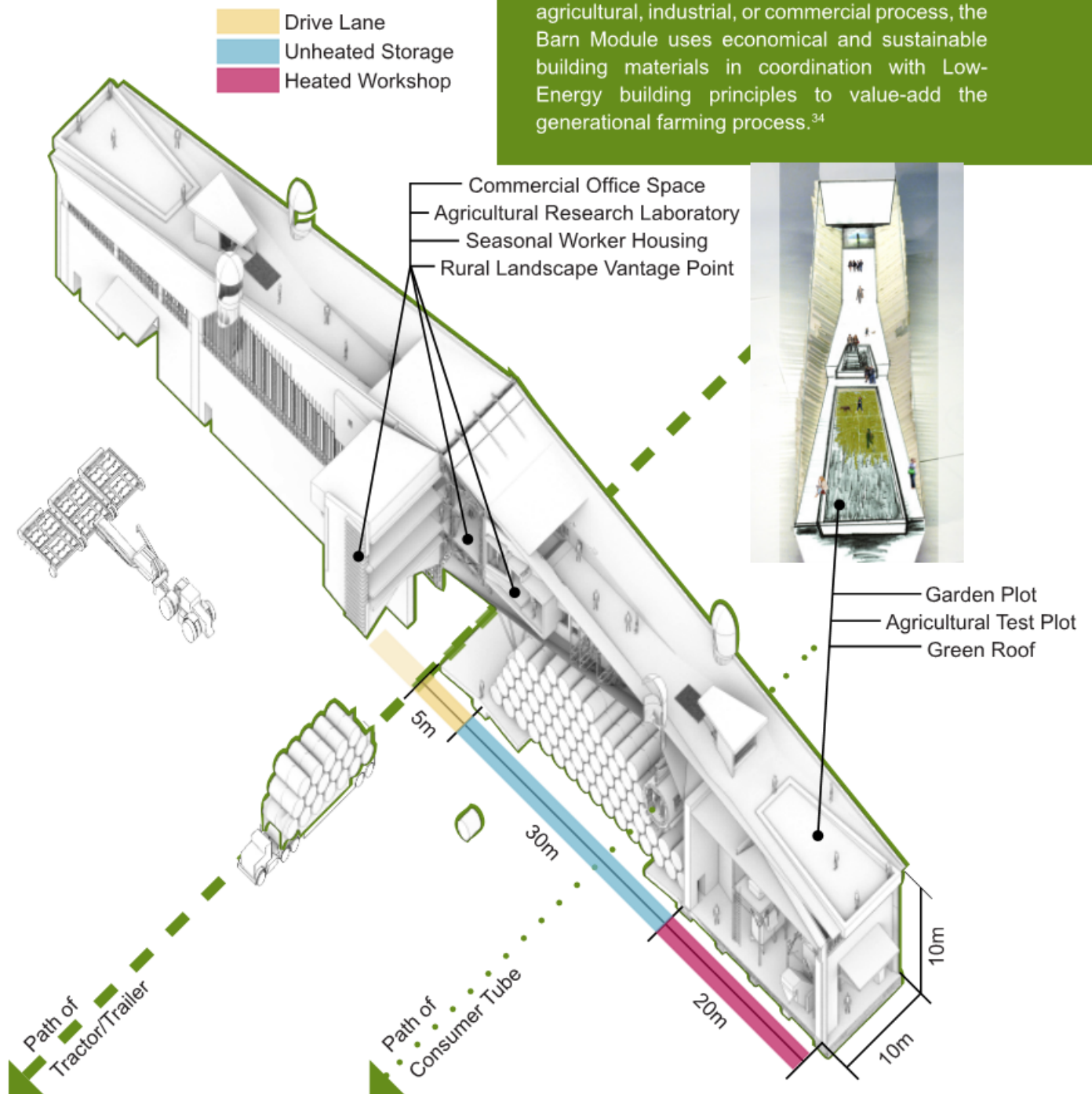

34. See Appendix B: The Barn I'd Raise, "Work_Decortication Facility," 306-309.

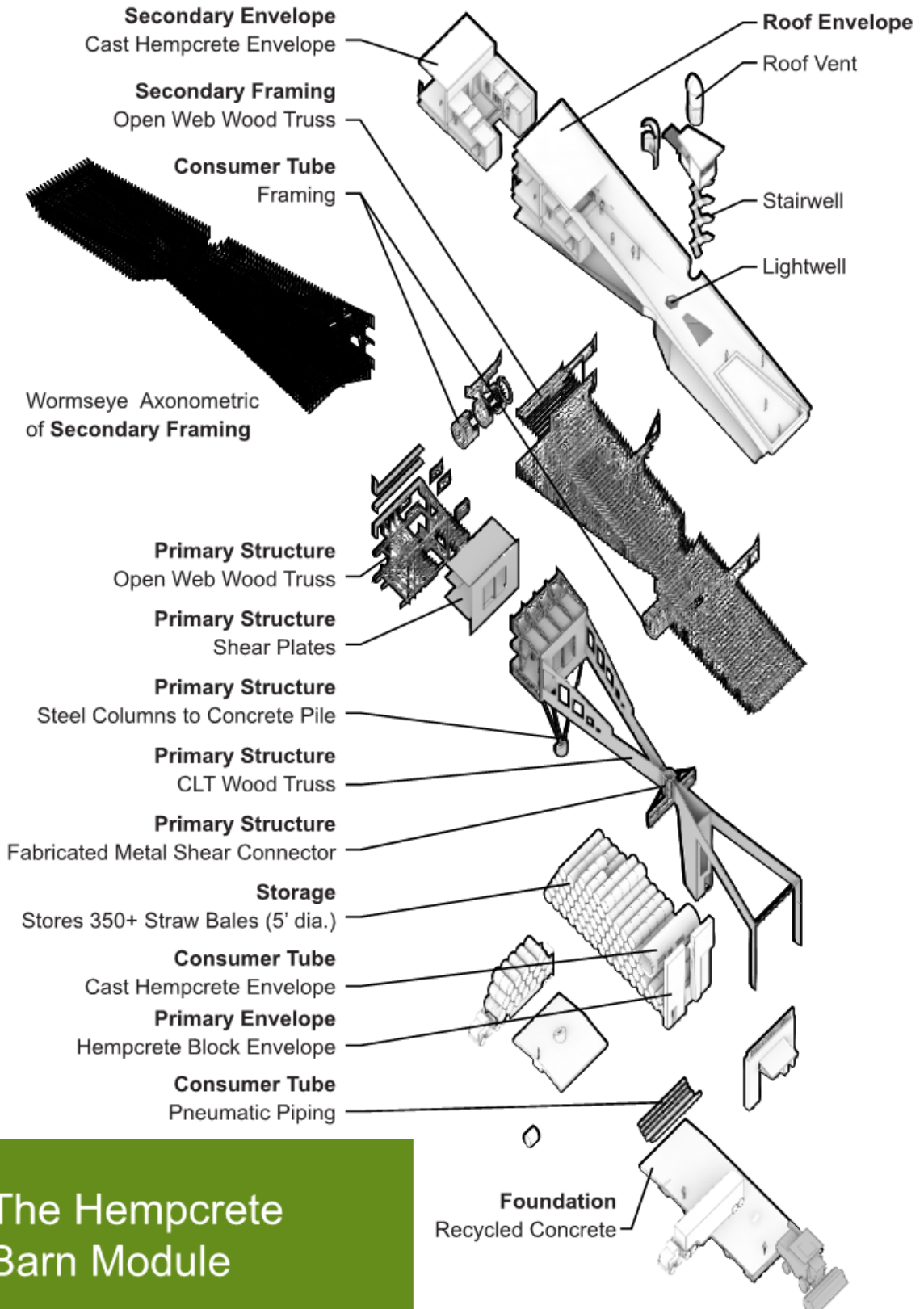

The Hempcrete Barn Module

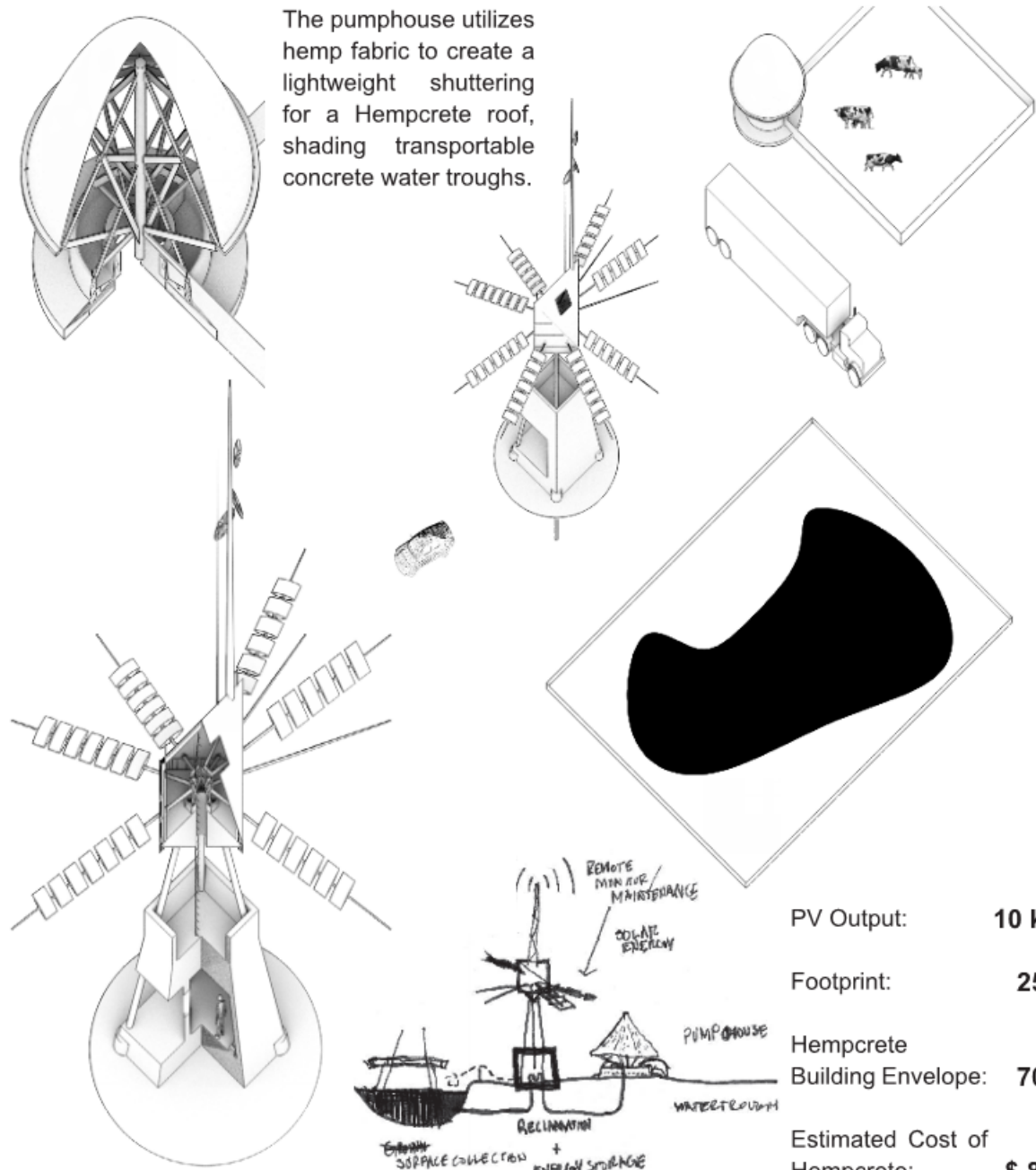

The pumphouse utilizes hemp fabric to create a lightweight shuttering for a Hempcrete roof, shading transportable concrete water troughs.

PV Output:	10 kWh
Footprint:	25 m²
Hempcrete Building Envelope:	70 m³
Estimated Cost of Hempcrete:	\$ 8210

The RE-tower functions as plug-and-play battery for water reclamation of dugouts contaminated with agricultural runoff - water that can be heated and pumped to livestock water troughs year round.

RE-Tower & Pumphouse

RE-Tower and Pumphouse are intended to disconnect the rural producer from the lifeline of the energy Grid. Autonomous power generation allows farmsteads to grow anywhere, providing energy for environmental reclamation anywhere it is needed. Access to renewable energies allows rural producers to focus on the agricultural process and the sustainable cultivation of resilient communities.³⁵

35. See Appendix B: The Barn I'd Raise, "Energy_RE-Tower," 264-267.

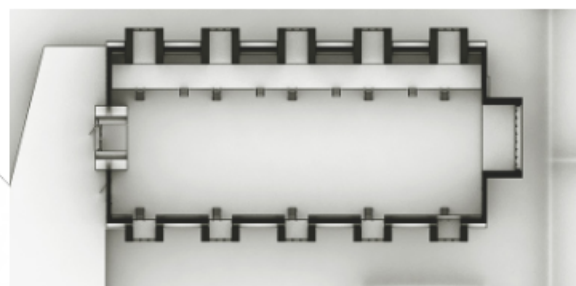
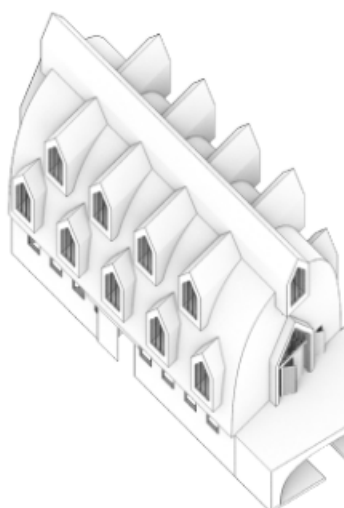

Studio Lofts over Woodshop Floor Plan

A large ramp allows vehicle access to the second storey workshop programming, doubly serving as a sunken root cellar to naturally cool agricultural produce. Opening the end-gable walls allows for a clear sightline from the interiorized farm process, through to the exposed rural landscape.

Livestock Capacity: **12-16**

Footprint: **200 m²**

Hempcrete Building Envelope: **250 m³**

Estimated Cost of Hempcrete: **\$ 29320**

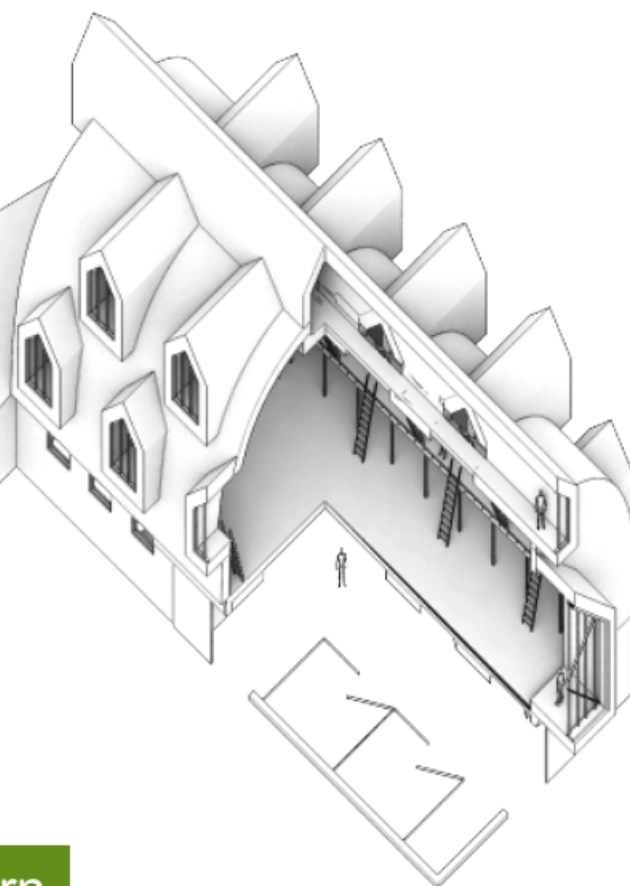

Woodshop Barn

Fashioned after the mail-order barns offered through Sears trading catalogues, the Woodshop Barn is a reincarnation of vernacular building process. As industrial agriculture made traditional barns irrelevant, the open storage space above the livestock floor is converted into farm workshop. Craft skills and value-add process intersect the individual. Dormer windows open an enclosed volume.³⁶

36. See Appendix B: The Barn I'd Raise, "Experience_Barn," 268-271.



Lookout Floor Plan

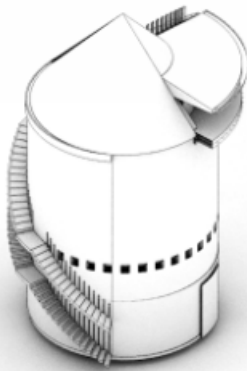
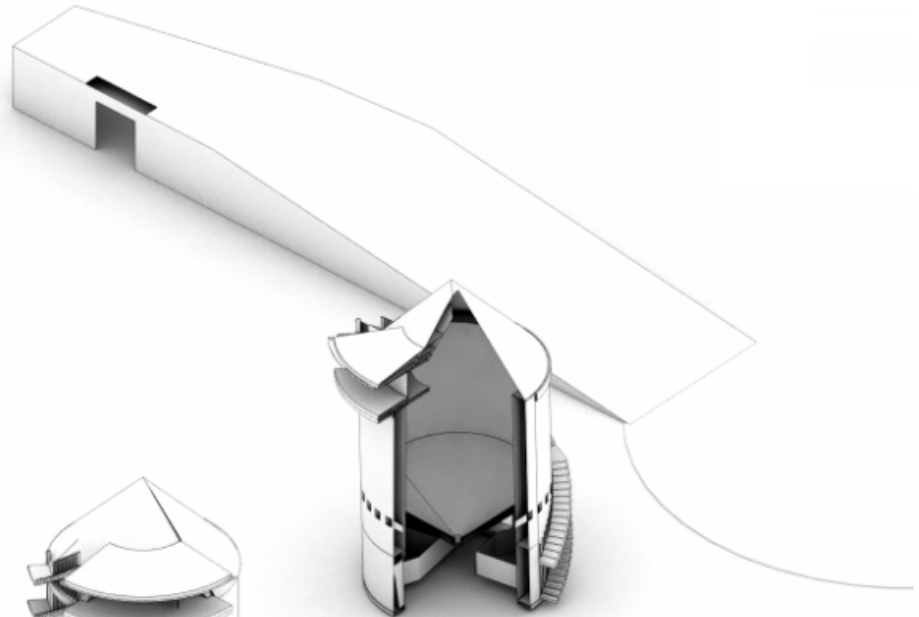

The ground floor of the Granary doubles as a livestock barn, utilizing the thermal heat massing properties of cereal grains stored above. Product is added and subtracted with pneumatic conduit as a safer method of grain circulation.

Internal Volume: **200 m³**

Footprint: **23 m²**

Hempcrete
Building Envelope: **120 m³**

Estimated Cost of
Hempcrete: **\$ 14075**

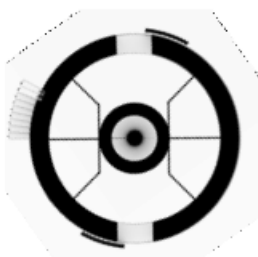

Ground Floor Plan



A spiral staircase provides a 360 view of the rural landscape as it extends from the farmyard to vantage point over the farm site.

The Granary

Built from a standardized vertical wood truss, the Granary is assembled from dimensional SPF lumber and sealed with a Hempcrete envelope. The advantage of the Hempcrete envelope is a breathable container wall, as it naturally removes moisture from stored material. To optimize use, a lookout platform offers vantage points over the rural landscape, doubling container vent to prevent bin overheating.³⁷

37. See Appendix B: The Barn I'd Raise, "Resilience_Granary," 274-275.

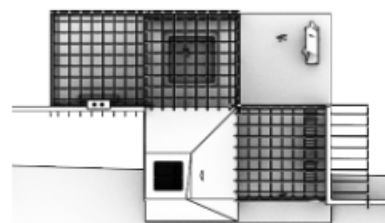

Roof Plan

A critique of the industrialized generational family farm is its lack of Play structures. Play is method of teaching and learning the experiential rewards of the agricultural process. Orienting the program to an individuals rest and relaxation counterpoints the intensity of the farming process, alleviating general stress. By making this building inherently social, it may become a cultural staple of the sustainable agricultural process.

Occupants **12-16**

Footprint: **125 m²**

Hempcrete
Building Envelope: **40 m³**

Estimated Cost of
Hempcrete: **\$ 4690**

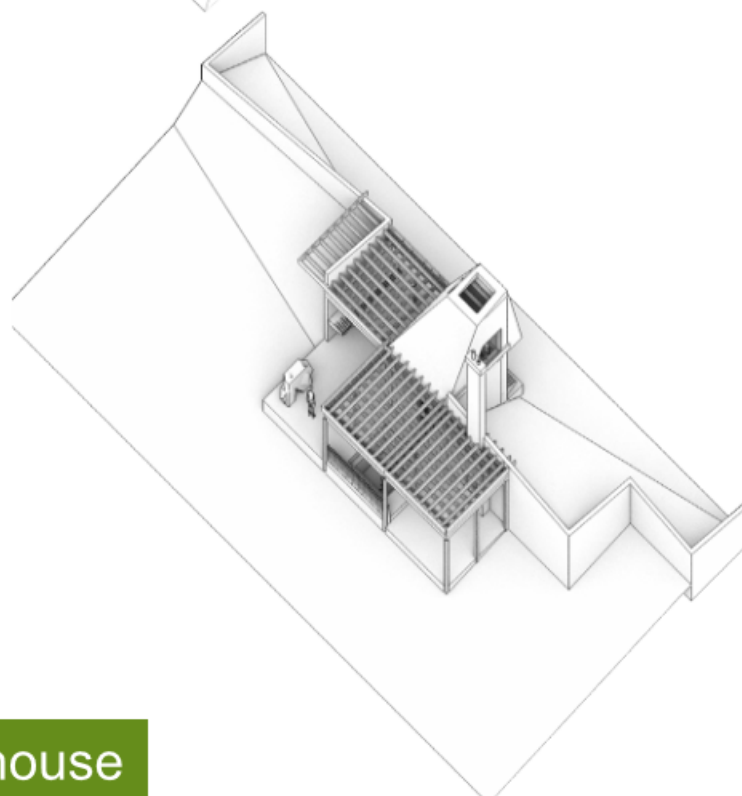

The Smokehouse

The Smokehouse incorporates three programmatic elements which define the Play process of the rural lifestyle; a sauna, an outdoor bath and an outdoor living room. This structure is sited to frame portions of the producers farmyard as it intersects the productive rural landscape and the generational family farm.³⁸

38. See Appendix B: The Barn I'd Raise, "Sensation_Smokehouse," 272-273.

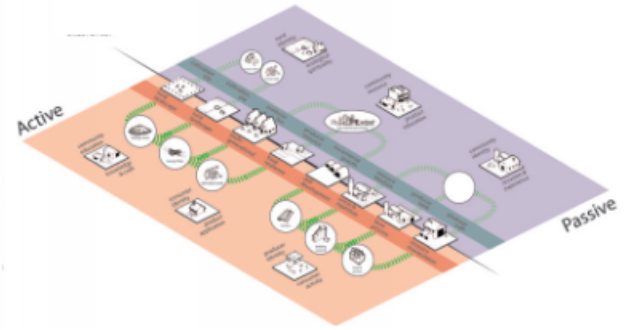
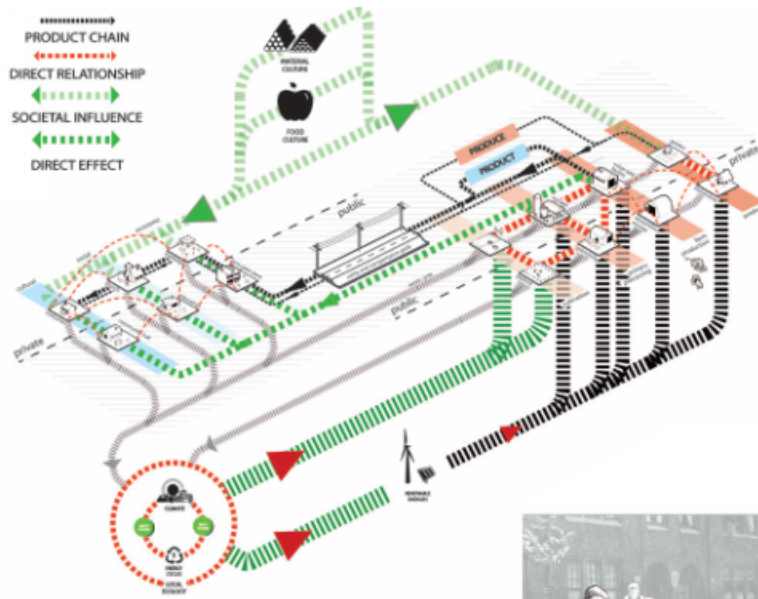

How does Aldo Van Eyck's design of the Amsterdam City Playgrounds unveil design principles that can revitalize rural communities.³⁹

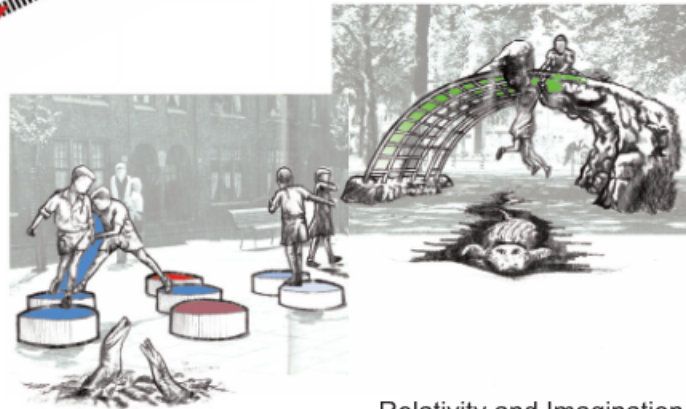

Relativity and Imagination.

Value Add Network

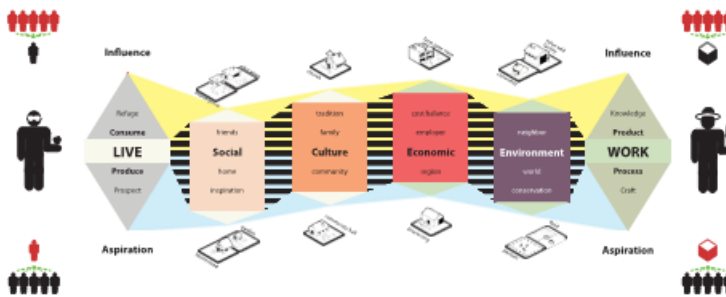

Teaching the Rural Process Through the Peripheral Experience

To enhance the viability of an agricultural rural process requires visibility and access to the unique program's and processes that make a vernacular community. Learn about the Peripheral Experience and how it Actively and Passively engages the urban consumer in the producers unique Value-Add process. When seeking to expand your customer base, think of the Consumer Tube.⁴⁰

39. See Appendix A: The Barn That Raised Me, "City as Playground," 137-145 .

40. See Appendix B: The Barn I'd Raise, "The Peripheral Experience," 145-155.

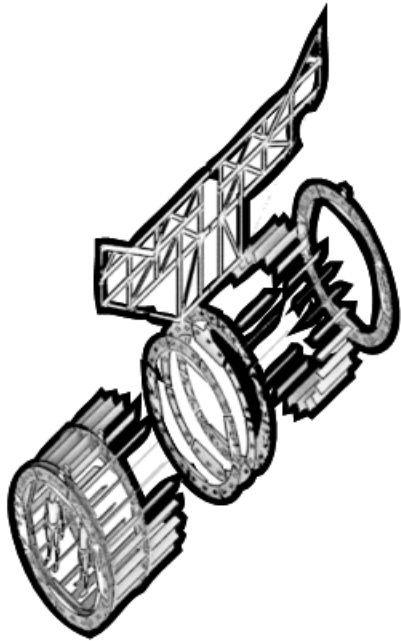
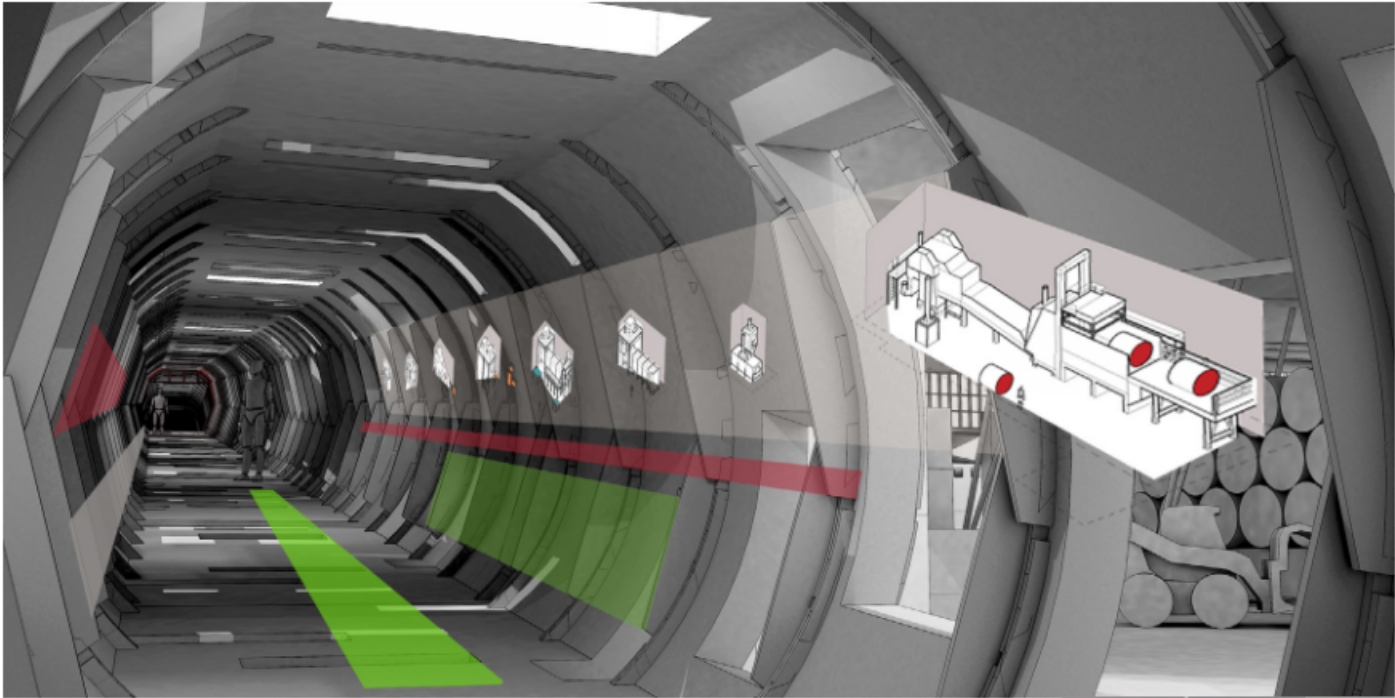

A sealed procession that may intersect any part of the rural process, the Consumer Tube is the rural producers advantage over corporatized agri-business. Building meaningful relationships between consumers and producers is vital to building resilient rural economies, an experience strengthened through the direct mental engagement of the urban consumer.

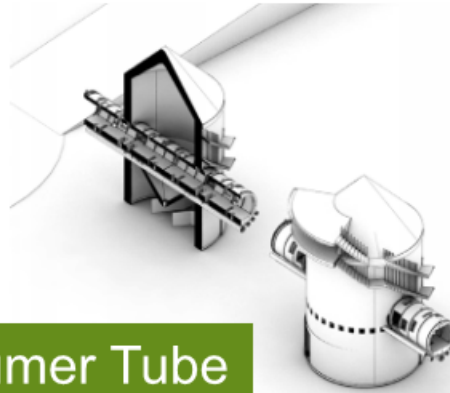

The Consumer Tube

Designed to hang from the ceiling of the Barn Module, the Consumer Tube is a versatile learning space that focuses the consumer towards a technical and cultural understanding of local agricultural process. A sensory experience intertwined with fact, the consumer is isolated from distraction until openings in the Tube wall reveal the relevant landscape, process and product that confirms the lesson.⁴¹

41. See Appendix B: The Barn I'd Raise, "Design_Consumer Tube," 276-279.

Tour the HempWorks Local Decortication Facility in Warwick, Alberta.

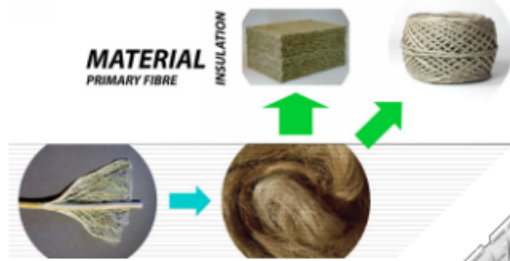

Tour includes 2 evenings at the Community Hall Bunkhouses and complimentary prairie cooking.

HempWorks Local is a sustainably developed Bio-fibre Decortication Facility that provides economical and environmental returns to the rural community of Warwick. The company is grounded in providing young farmers meaningful career employment in the cultivation of local Biofibre industries.⁴²

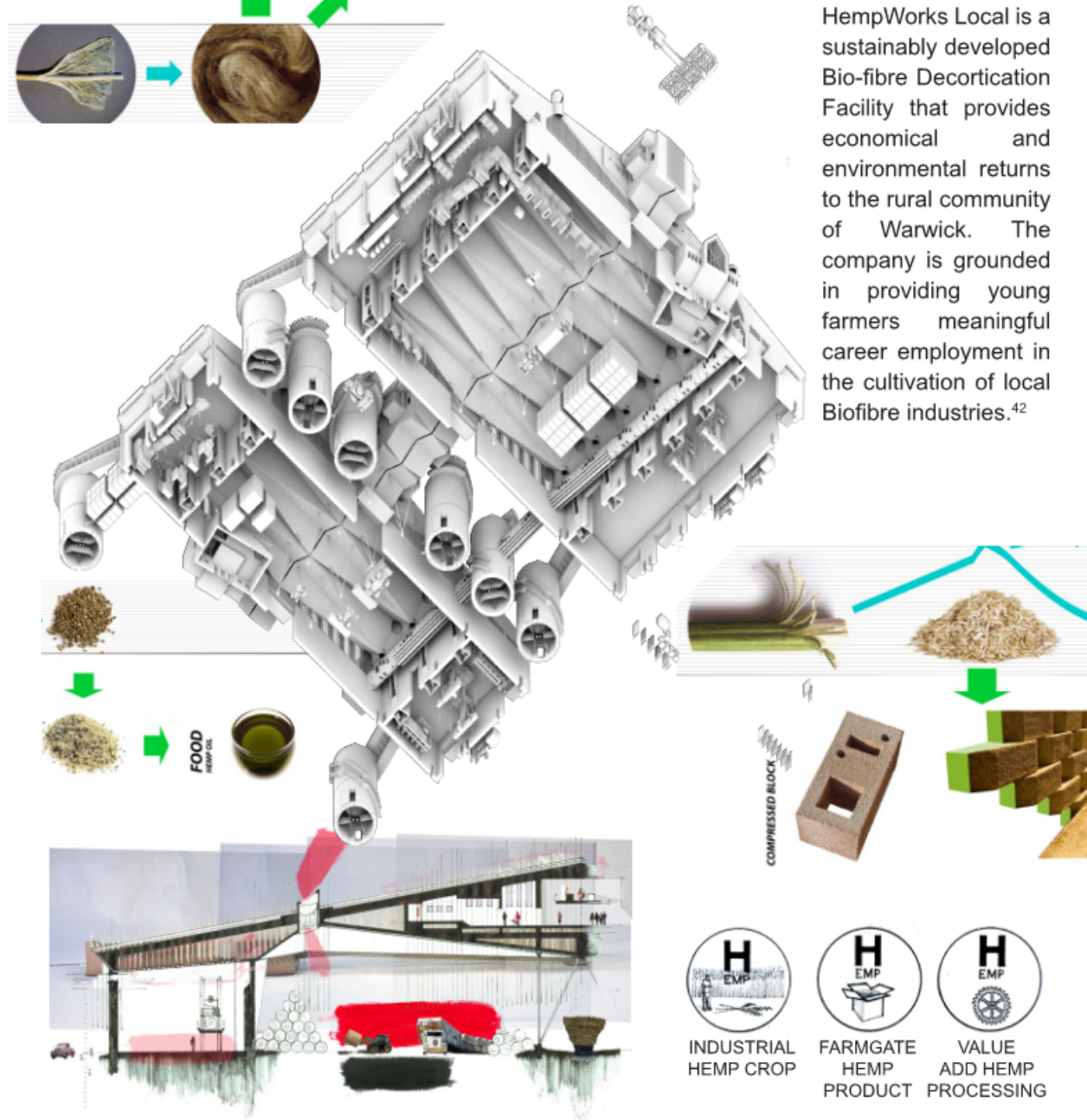

42. See Appendix B: The Barn I'd Raise, "Work_Decortication Facility," 304-319.

Sustainable Community Planning Guide



It's Yours for the Asking

Future Farms Media is committed to sustainable rural communities and believes that the spreading of common knowledge Order your FREE copy of Smart Code, V.9.⁴³



Mail Coupon TODAY

Send for Your Copy-It's FREE!

Name.....
 Postoffice.....
 State.....
 Rural Route..... Box No.....
Please give both your Route and Box number if on a Rural Route
 Street Address.....

43. See Appendix A: The Barn That Raised Me, "Community Resiliency," 187-197.

Book Your Event at the Community Hall in Warwick, Alberta

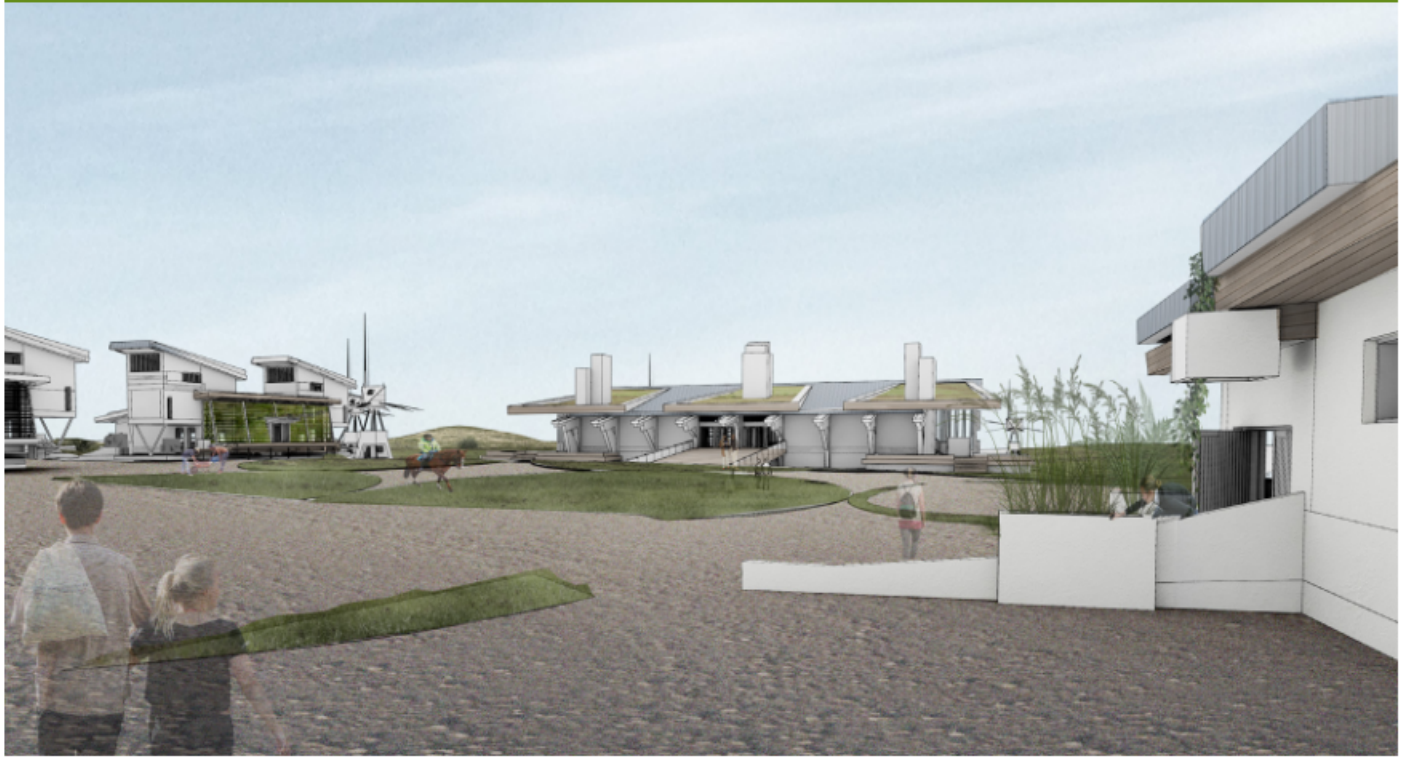

The HempWorks Local Cooperative
& Future Farms Media



Appendix A: The Barn That Raised Me

This chapter will explore the vernacular rural landscape in the context of the Albertan generational farmer. The concept of rural lifestyle has significantly changed in the post-war development of industrialised nations, forever changing the notion of the modern farm. To preserve established notions of the rural lifestyle in harmony with natural systems will require the architect to assess the process of industrial agriculture and not become focused on the technology alone. What is the best farm model?

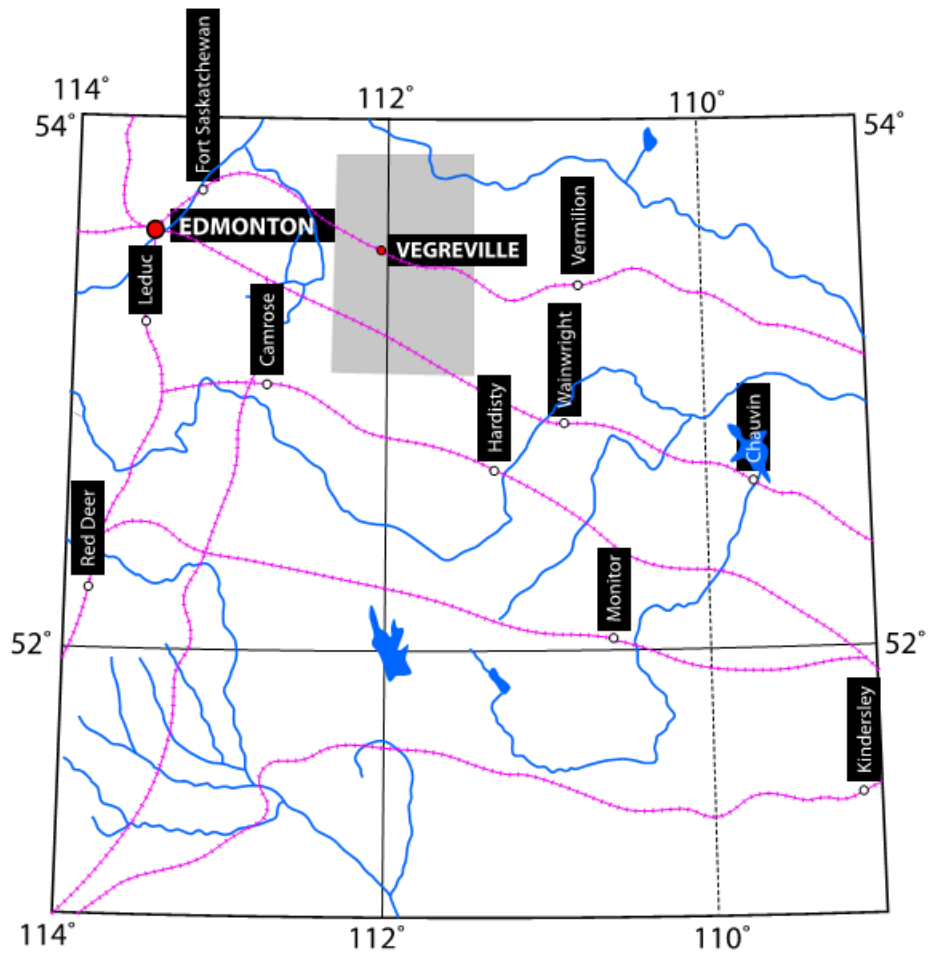

Context Map of Vegreville, Alberta.

Shaded area denotes the Vegreville and Surrounding Area, c. 1918, map. Rivers and railines precipitated the highway and rural grid.

Base Image Source; Sheppard, A.. 1921. "Vegreville, Alberta." 1:190,080. "Geological Survey of Canada, Multicoloured Geological Map." Last modified April 2, 2016. <http://geogratis.gc.ca/api/fr/nrcan-rncan/ess-sst/e1cce35f-ab26-5f9b-8ddd-c518c5a374ce.html>

Section 1: Observation and Theory

Rural Western Canada is a vast wealth-creation machine. If you throw a stone in a rural area, you hit an oil field or a grain field; a potash, uranium, diamond, coal, or gold mine; a herd of cattle; or a stand of timber. This great wealth however, is not captured in rural areas. Instead, rural areas are struggling: farmers are facing bankruptcy, stores are closing, schools are increasingly empty, young people are leaving, roads are disintegrating, and the economy is contracting.

- Epp and Whitson ⁴⁴

As a direct offspring of the industrial agricultural process I have become very familiar with the reality of the petroleum idol and the socio-cultural implications it has wrought on the prairie landscape.⁴⁵ The most evident lesson being there are few commodities which human civilization actually 'needs', and that 'want' is a reason for system complexity and technological dependence. Every person needs food, yet every person wants cars, cell phones and Starbucks; society constructs the reality of our consumer habit. If products influence the way people consume then it is possible to design products which teach consumers conservation, stewardship and the significance of a consumers role to local systems. As designers, we stand to play a role in how subsequent generations inhabit our earth and the material culture they adopt through the emplacement of economic, social, cultural and environmental principles we establish today.

44. Epp and Whitson, *Writing off the Rural West*, 28.

45. Tyler Dixons MArch thesis, *Exodus: The Disappearing Rural History of Alberta*, architecturally explores the decayed conditions of Alberta's rural landscape under the provision of industrial agriculture and oil economics. The critical lessons of this document reveal the transient nature of industrialization which disconnects consumers and producers from their landscapes.

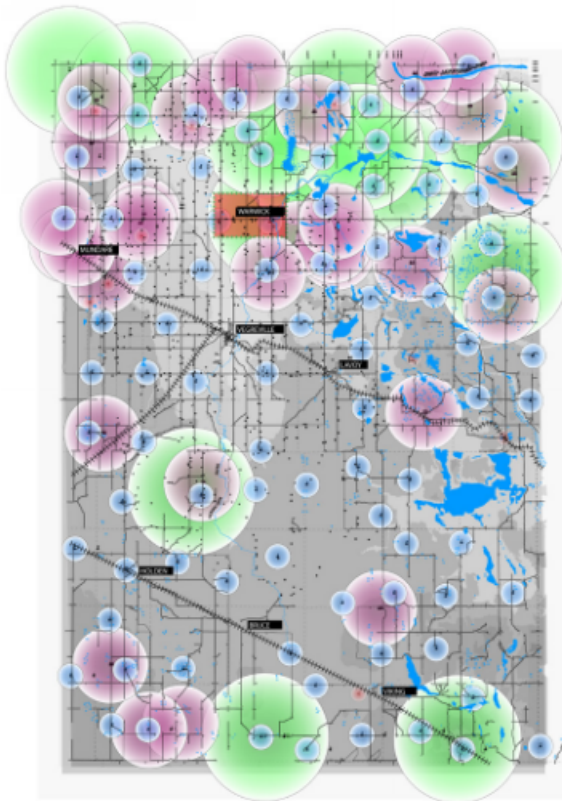

VEGREVILLE AND SURROUNDING AREA
c. 1918

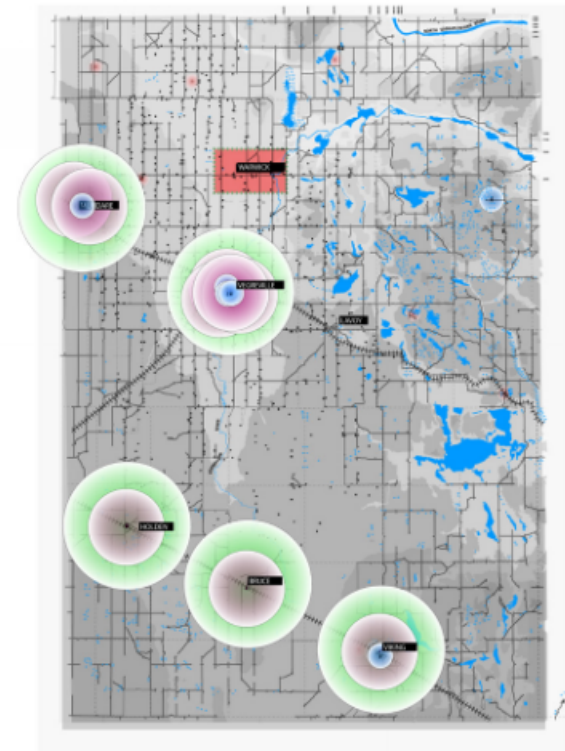

VEGREVILLE AND SURROUNDING AREA
c. 2016



The generational family farm has undergone a dramatic transformation as the centralization of food production and community services has removed many of the social, cultural and spiritual anchors from the rural landscape. Architecture stands to fill the void with design principles that build resilient community models to keep family farms in Alberta.

Base Image Source; Sheppard, A.. 1921. Vegreville, Alberta [Map]. 1:190,080. "Geological Survey of Canada, Multicoloured Geological Map." Last modified April 2, 2016. <http://geogratis.gc.ca/api/fr/nrcan-rncan/ess-sst/e1cce35f-ab26-5f9b-8ddd-c518c5a374ce.html>



Typological Anchor -
Spiritual Assembly

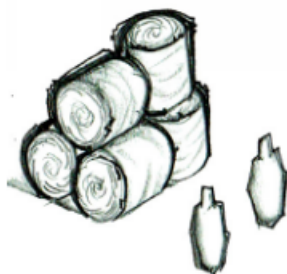

Typological Anchor -
Agricultural Product



Typological Anchor -
Community School

As my grandparents generation was responsible for establishing much of the rural infrastructure which connects the entirety of the prairie region; adapting their labour intensive, yet sustainable, agricultural process into industrial agriculture.⁴⁶ My parents generation was limited to adopting industrial agriculture as their farming practice due to increased competition with corporate farms and global markets. The consequence of industrial agriculture and what successive generations face would take too long to summarize in this document, but is the ground from which my experience of the industrial rural landscape stems. Ultimately, it could be argued that previous generations of farmers not only refined and elevated agriculture to a technological proficiency, but defined the limitations of that system and established many precedents for what offspring generations of farmers should not do. Given the calamity of industrial agriculture, how do successive generations of producers and consumers begin to correct the predetermined course set for our rural landscapes?

I have been careful in my selection of case studies which accurately represent the transitional effects of industrial agriculture and the subsequent opportunities it reveals to the next generation of local producers. The hamlet of Warwick stands as marker of a decayed prairie town, yet remains a bastion of community resiliency, and serves as the rural fabric that precedes the architecture. To begin, the architect must clearly establish the typological anchors of the generational family farm and the rural community

46. Fluck and Baird outline the industrial agricultural process in their book, *Agricultural Energetics*, detailing a corporately dominated and chemically dependent food cycle, describing the ultimate cost of its implementation into modern food systems.

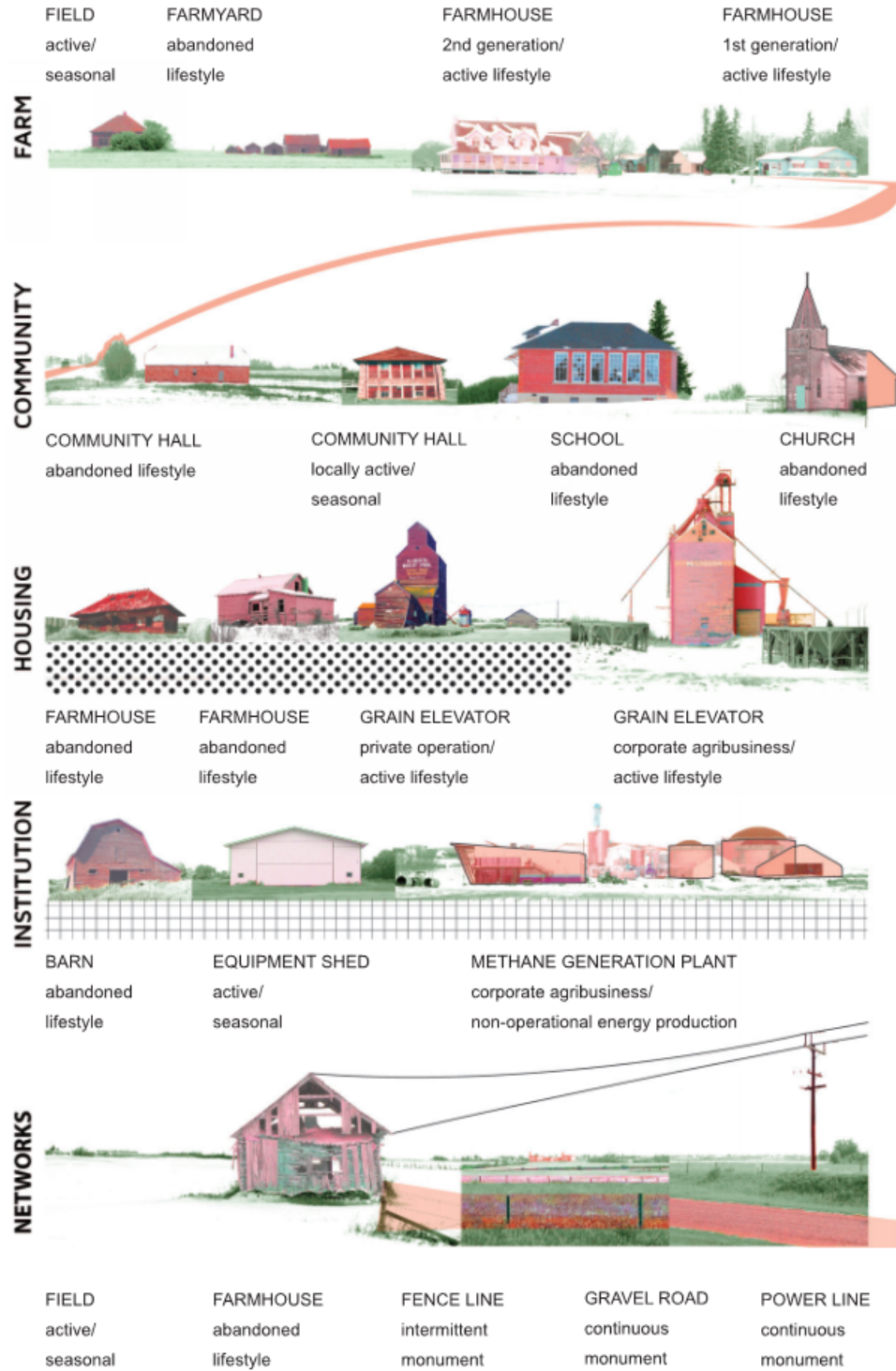

Mapping typological anchors and cultural transformation in the County of Minburn No. 27, Alberta.



Typological Anchor
- Social & Cultural
Assembly



Typological Anchor -
Rural Residence

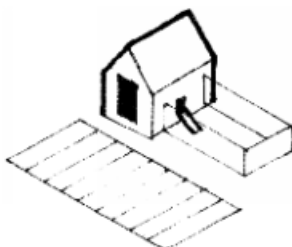

Typological Anchor -
Food Resiliency

it serves. In searching for alternatives to the industrial process, it is important to validate the intrinsic process of the rural community that requires intervention. To facilitate this design process, I have developed case studies of my families generational farming process as it exists within the rural community of Warwick today. The Grandparent Farm demonstrates the role of the generational farm in teaching the individual to become a part of the rural community - the Live. The Parent Farm demonstrates the adaptability of the generational producer to remain in the rural landscape through the value-add process - the Work. The Offspring Farm demonstrates the next generation of rural producers demand for a more integrated rural experience that provides a cohesive Live/Work/Play experience.

These sites exist within a 5 mile distance of Warwick community and demonstrate the present metamorphosis of the rural landscape become industrial. What isolates the generational family farm from the generic condition is the local community that serves the family farm. However, as architect, it is critical to recognize the distance that currently exists between the urban and rural process. To catalyze the sustainable rural landscape will require extensive mapping of the regional landscape to define the cycles and systems which will inform a sustainably integrated architecture identifiable beyond the farmyard.

A Landscape in Time_Community

As designers begin to interpret the rural landscape and attempt resolution of its complexity, it is evident that conventional definitions of planning, architecture and agriculture must be assessed not as independent design

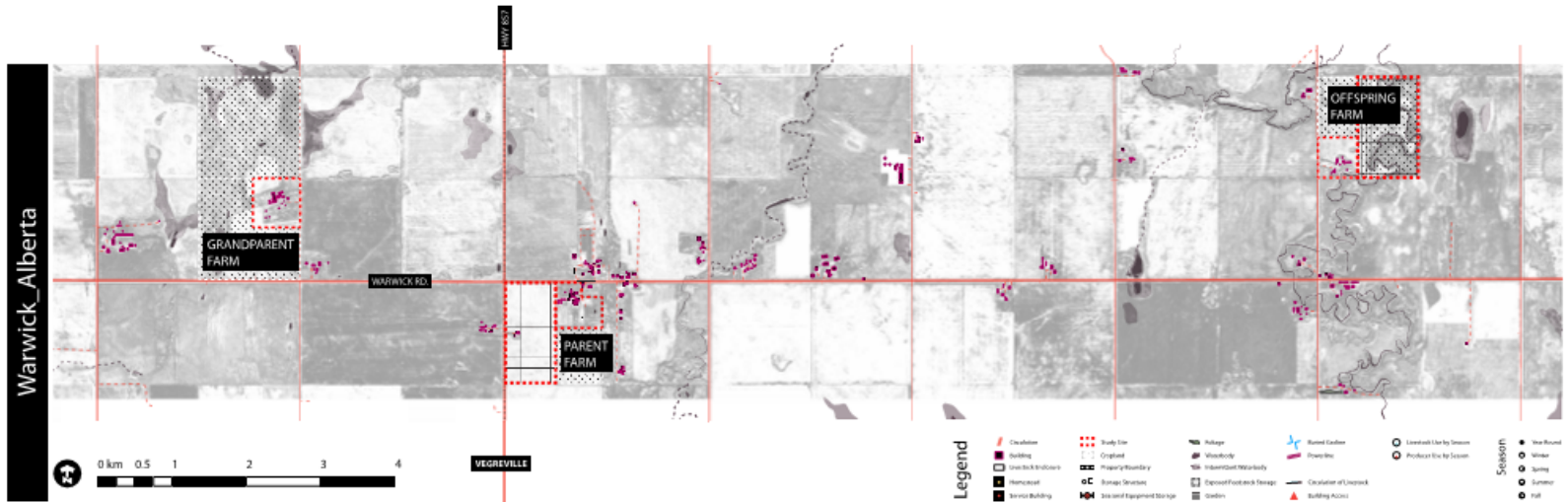

Map of Warwick RD, Alberta, highlighting the three case study sites of a generational family farm.

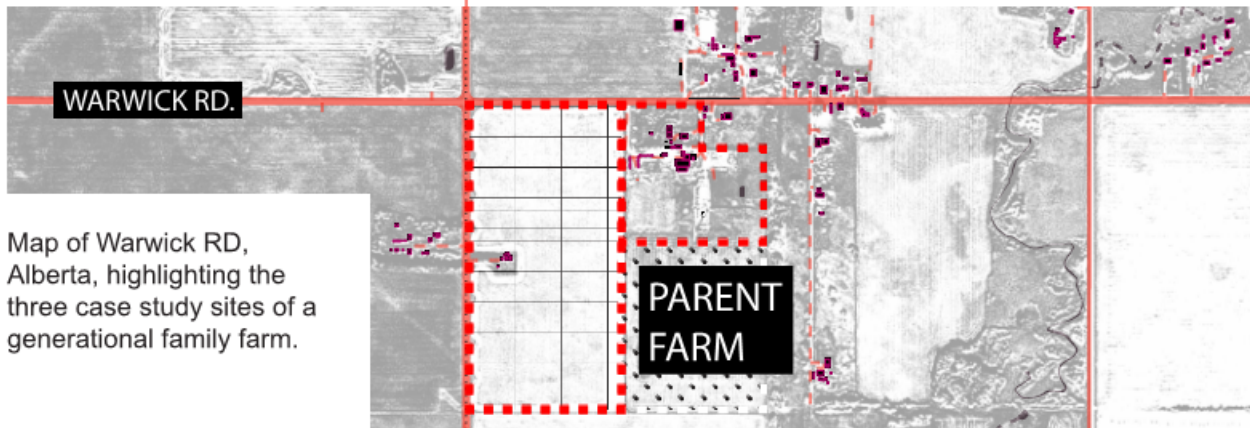

Map of the rural community of Warwick, Alberta.

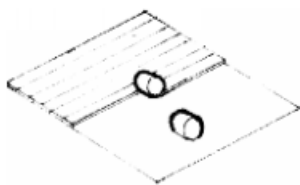

Typological Anchor -
Productive Landscape



Typological Anchor -
Food Product

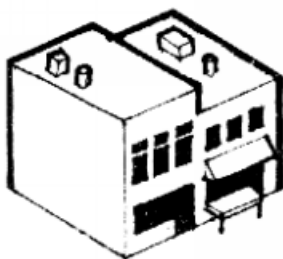

Typological Anchor -
Economic Commerce



Typological Anchor -
Food Process



Typological Anchor -
Animal Husbandry

entities, but as cohesive design systems. One critical issue that designers face is rationalizing the scale to which a re-imagined network exists in the rural landscape. Proximity is no longer required by the industrial agriculture process as mechanization disassociates energy from labour - yet proximity is critical to the sustainable process and to the rural community. The first lesson that applies to the resilient rural landscape is assessing the notion of density and how it is unveiled through the rural fabric.

Warwick, Alberta

Driving north on highway 857 (HWY 857) from Vegreville, you experience a sensorial procession through the rural landscape - common elements such as the wind belt and fenceline are rhythmic vertical planes that seamlessly intersect. To the untrained eye this procession is monotonous, kindly punctuated by sightings of livestock. To the trained eye, these elements reveal a definitive pattern of habitation within the rural landscape and express a vernacular occupation. Definitive landmarks precede the destination and inspire anticipation of arrival, or recall memory of past experience.

Approaching the community from the east, the traveller becomes aware that two generational farms mark the western boundary of the Warwick hamlet. To the north of Warwick RD stands a third generation beef feedlot, an Intensive Livestock Operation (ILO). Directly south of the feedlot stands my home, Christie Lane Farms, another ILO. At the heart of Warwick is a small community hall where locals still gather for public meetings, seasonal celebrations and private functions. Directly south from the hall and across



The tranquility of the rural landscape is transcendent and juxtaposes the activity of the urban lifestyle. To attach consumers to this idea of living in reciprocation of the productive landscape will require the architect to derive the specific activities, forms and process that simultaneously engage the rural and urban realms.



Hempcrete
Plywood
Hempboard

the asphalt paved, Warwick RD, are the community baseball diamonds which formerly hosted local tournaments, but are recycled as grazing pasture today. These two sites are wholly maintained through volunteer efforts from the community and remain social and cultural anchors within the rural landscape despite their infrequent use.

The entire procession through Warwick community is visceral, experienced through the car window in less than a minute. The hamlet concludes once the traveller crosses a bridge over an intermittent stream, passing the privately operational grain elevator. The eastern edge of Warwick is defined by the Warwick Grain Elevator, built as a cooperative effort between local farmers seeking greater returns on their harvest early in the 20th century. The grain elevator towers over the rural landscape as vertical monument to process and reminder of the communal effort of a rural lifestyle. Other artifacts remain buried in the dirt which recall a better serviced rural community; the stone foundation of a one-room prairie church become garden bed or the interspersed railworks that lead past the ball diamonds, southwards to remnants of a rural train station.

Foremost, the rural hamlet of Warwick stands as a generic model of the industrialized prairie landscape and reveals a resilient agricultural community model based on generational farming. The beef feedlot which defines the western edge of the hamlet formerly hosted 2000 head annually at its peak operation in 2010, and is now operating as a intensive grain producer. Christie Lane Farms and Weiss Mechanical Services lies directly south of the former feedlot and maintains a beef cow/calf operation of 300 head;

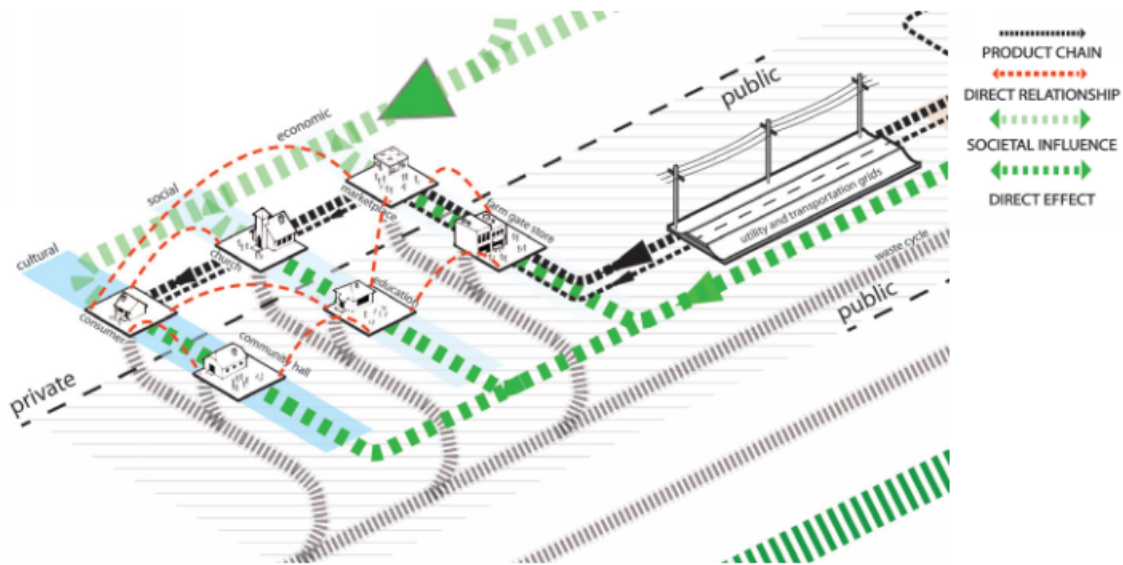

Rural Community Typologies.

Modelling the Urban Built form and the modernist consumer cycle that extracts resources from 'where-ever' to anchored nodes of dense consumption. Business as usual ignores the potential of the local producer to feed urban communities

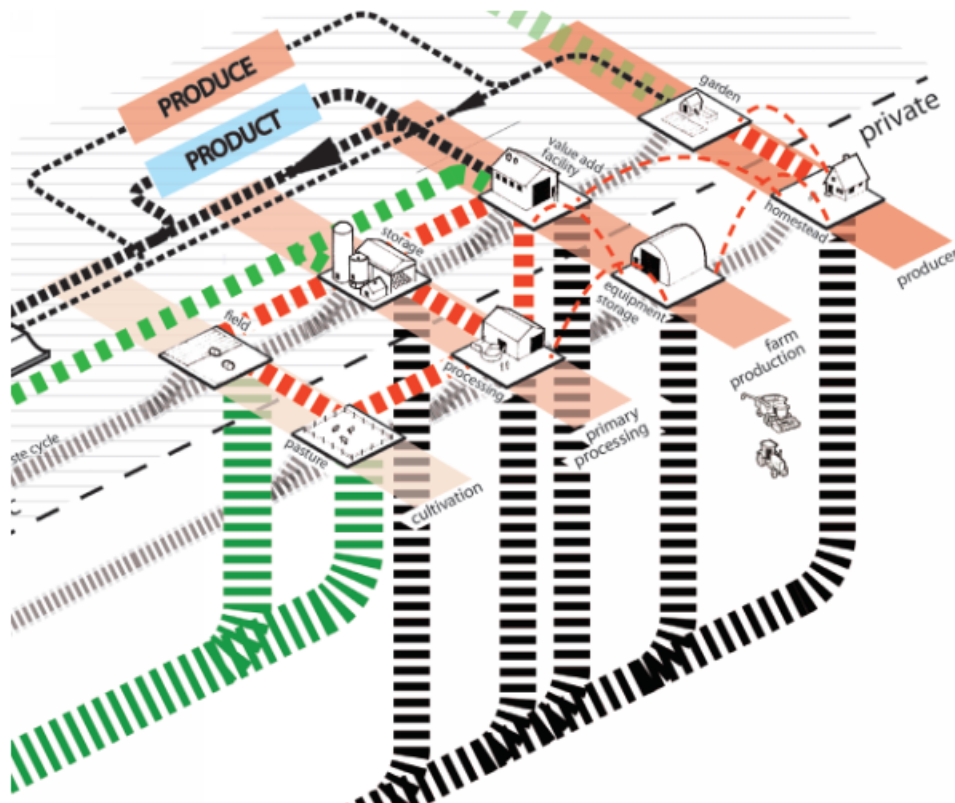

Generational Family Farm Typologies.

Modelling the rural built form and industrial modernism which demands a quantitative agricultural product above a qualitative agricultural product. Business as usual drives the generational farm to adopt the industrial agriculture practice to economically maintain their lifestyle.



Christie Lane Farms,
Generational Family Farm



Productive Field/
Rented Landscape



Parent Farm

as well as operating a fully licensed industrial mechanic service shop, open 6 days a week. In regards to the rest of the Warwick community, the neighboring residents maintain a rural lifestyle for the proximity of nature and the solitude of space.

A unique example of rural density, the hamlet demonstrates proto-urban conditions due to the scalar mix of industrial agricultural practice, generational farming and private rural residence. The mechanization of the rural landscape and subsequently the centralization of typological community services follows the urban precedent. In theory, the rural landscape could set a precedent for a new model of urban growth through a sustainable material culture. As the community hall of Warwick is the resilient building typology still connecting the rural community, the community hall becomes the centre of a resilient agricultural community, and the cultural venue of the generational farm.

The Generational Farm_Live

When seeking a desirable visage of modern agriculture, it seems apparent that the family farm remains a romantic idealism, a totem to self sufficiency and resiliency. In light of the dramatic shift in family structures and a receding rural workforce, the generational family farm can be considered a successful Live/Work model when successive generations of producers remain in the rural landscape. This dedication to lifestyle results from the metabolization of unique experience within the rural landscape and direct participation in the agricultural process, enhanced by the social and cultural networks attached to the family. Wherein the child grows and returns to an environment to build their

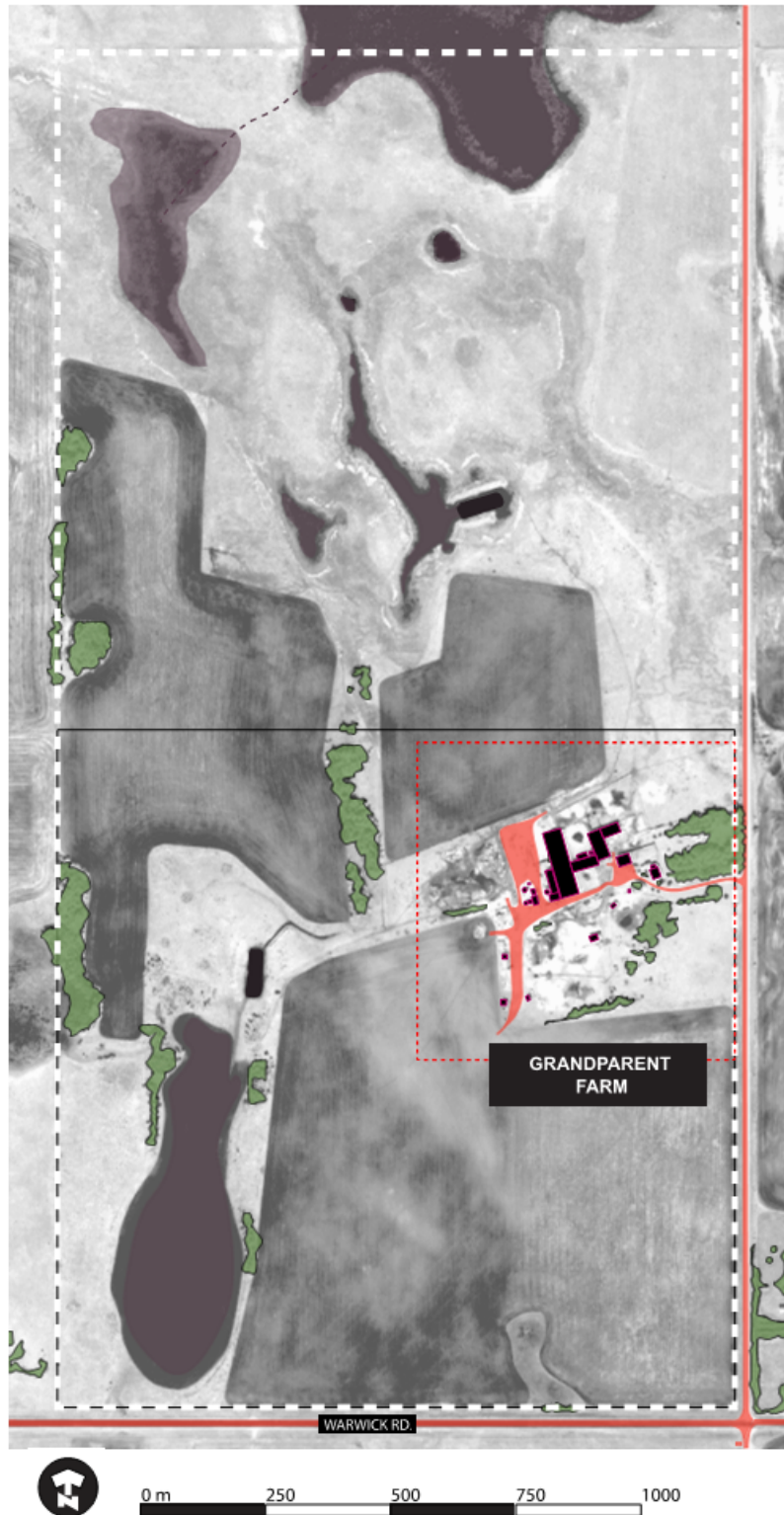

Grandparent Farm Landscape.

Modelling the precedent built form and the seed point of industrial modernism. Industrial agriculture demands a quantitative agricultural product above a qualitative agricultural product. Business as usual drives the generational farm to expand the industrial agriculture practice to maintain their lifestyle process.

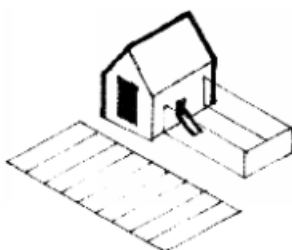

Typological Anchor
- Garden & Chicken
Coop



Typological Anchor
- Generational
Farmhouse

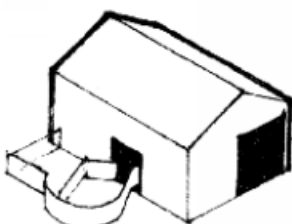

Typological Anchor -
Agricultural Process

own life, they strengthen the community which raised them. In understanding the generational family farm, the observer must realize that the farm is not an isolated event occurring in one place and time, but is timeless and boundless; occurring simultaneously through the collaborative identity of the agricultural process.

What is obvious of the next generation of agricultural producers is their intention to remain in the rural landscape. A conversation with any of these producers would reveal a dream carried by a desired experience, a familiar comfort, and the endless potential of a great prairie sky. When someone decides to farm, it is most likely because they have found their dream occupation which objectively meets their Live/Work needs and subjectively meets their need for personal growth and Play. The rural experience is unique to the individual, yet it is evident that the nature of shared love, labour and loss for the farm is an opportunity for cohesive social bonding, and the reasons that rural communities survive today.

The Grandparent Farm

My paternal grandfather, Herb Weiss immigrated to Edmonton, Alberta in 1959 and settled into a dairy farming operation west of the city in 1966. Prior to settling within the rural landscape, my grandfather worked as a carpenter in Edmonton, building residential homes. Herb moved an hours drive east of Edmonton to Vegreville, Alberta in 1972 where he began a family dairy farm 10 miles north of the agricultural community. With an initial herd of 17 dairy cows, this family grew to a household of 10 and was raising 150 dairy cows by 1976. After my father left the farm in 1979

Herb Weiss Farm - Dairy Operation est. 1972

Phases

- 1972 - 17 Head, Dairy Cattle
- 1973 - 34 Head, Dairy Cattle
- 1974 - 75 Head, Dairy Cattle
- 1976 - 150 Head, Dairy Cattle
- 1989 - Dairy Operation Closed, Beef Cattle replace
- 2006 - Farm Operation sold to Child
- Present - Operated as Hobby farm, 20-40 Beef Cattle operation, Child is primarily employed in Agricultural Industry



- ▲ Building Access
- ▬ Circulation of Producer
- ▬ Circulation of Livestock
- Homestead
- Service Building
- ◻ Storage Structure
- ◻ Livestock Enclosure
- Livestock Use by Season
- Producer Use by Season
- ▨ Crop Harvest Storage
- ⊕ Seasonal Equipment Storage
- ⊕ Garden
- ▨ Greenhouse
- Foliage
- Season**
- Year Round
- Winter
- Spring
- Summer
- Fall



Diagramming the agricultural process of the Grandparent Farm and the seasonal programming of the productive field.

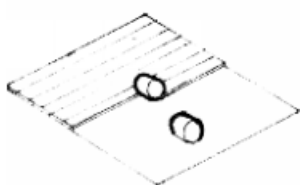

Agricultural Process
- Productive
Landscape



Agricultural
Product - Cereal
Grains



Agricultural Process -
Dairy Cattle



Agricultural Product -
Dairy Products

to train as a mechanic, the dairy farm was managed by my grandfather and worked by my aunts and uncles. My grandfathers dairy operation would close in 1988, yet he retained an assortment of livestock in fashion of the hobby farm. A genuine interest in nature and a provision for growth made his occupation pure joy.

The built form of the Grandparent Farm is one defined by proximity, wherein the harsh Alberta winters and the process of dairy farming resulted in an agglomeration of insulated and non-insulated agricultural shells. Generic agricultural building typologies are adopted for their utility and assembled through the imagination and ability of the farmer-become-builder, who ultimately defines how built form assists the local agricultural process. An attribute likely developed through the widespread documentation and dissemination of standard framing and design details crafted through agri-business advertisements and trade catalogues.⁴⁷

What is evident of the previous rural landscape, prior to industrialization, is the cloned agricultural form that stems from locally developed building craft and conventional agricultural process. A process that is inherently passed by the Grandparent to their offspring, a.k.a. the Parent, who in-turn, teaches their Offspring - and the generational farm cycle continues.

47. The nature of consumerism in remote prairie towns was highly dependent upon trade catalogues and the postal service to acquire commodities that were not produced locally. Sears, Roebuck and Co. (Sears, *Modern Barn Equipment*, 1928) developed a national identity through its vast development of mail-order catalogues that would connect remote communities to industrial networks. The provision of ready-to-build structures meant farmers could settle rural landscapes faster through commercialized building convention.

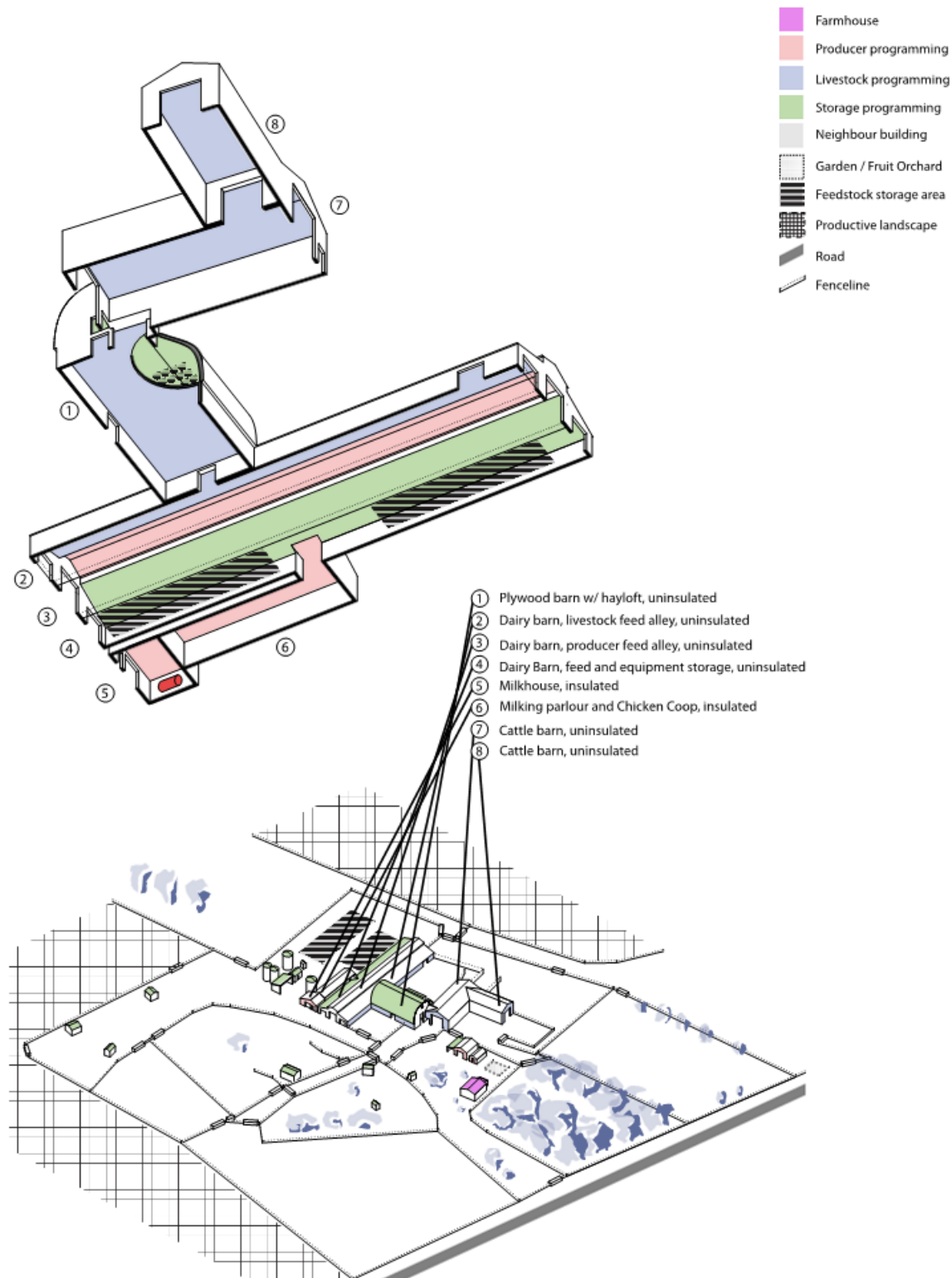

Grandparent Farm and the Configurative Process.

Diagramming the built form of the Grandparent generations' agricultural process. Structures are modularized, and programming is a determinant of pre-existing associations. The configurative assemblage of the Grandparents barn into a germinal program resembles the organic evolution of medieval cities.

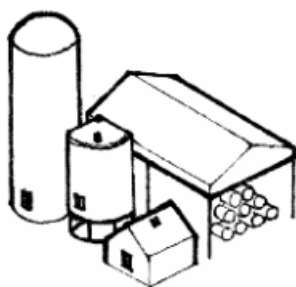

Rural Lifestyle -
Product Resiliency

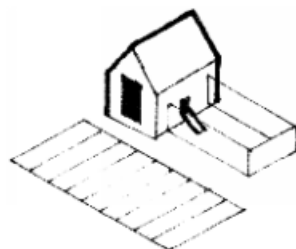

Rural Lifestyle -
Self-Sustenance

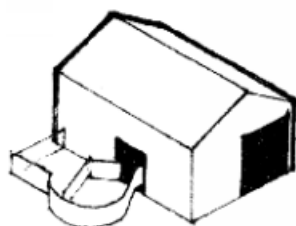

Rural Lifestyle -
Process Resiliency

The dynamics of the Grandparent-Parent-Offspring social relationship reveals how the Parent and Offspring develop strong emotional ties to the rural landscape as a result of the Grandparents initiation in the agricultural process. As the Parent farm begins and Offspring arrive, there is always a challenge to complete the seasonal agricultural process whilst raising young children, and as the labours become heavier for the Grandparent. The value of the generational family farm to the agricultural process is a complete sharing of time, space, and experience as the Parent assists the Grandparent agricultural cycle. Where the Grandparent utilizes the youth, energy, and skill of the Parent, the Parent utilizes the wisdom, craft, and patience of the Grandparent to contain the youth and energy of the Offspring. These periods are most influential when the Grandparent teaches skill and experience to the Offspring so that the Offspring can readily assist their Parent; a cycle of teaching, learning and doing which allows the rural generational farm to persist within an industrial agriculture landscape.

With each generation, a new set of challenges, opportunity, and choice is placed in that path. The next generation of farmers, the Offspring, will not have the advantage of youth, as those future farms will be incapable of raising the necessary capital needed to start a farm today.⁴⁸ As the pool of successive farming generation shrivels, it is more necessary than ever to revitalize interest in this

48. Epp and Whitson, eds., *Writing off the Rural West*, xxxii. Comment by the vice-president of the Royal Bank of Canada describes the polarization of the rural landscape: "20 percent of farm operations - the big, technology-savvy, credit-worthy ones - are responsible for 80 percent of production. It is the relatively unproductive majority of farmers who, in his view, cannot compete in a climate of agribusiness consolidation and are continually clamouring for government assistance."

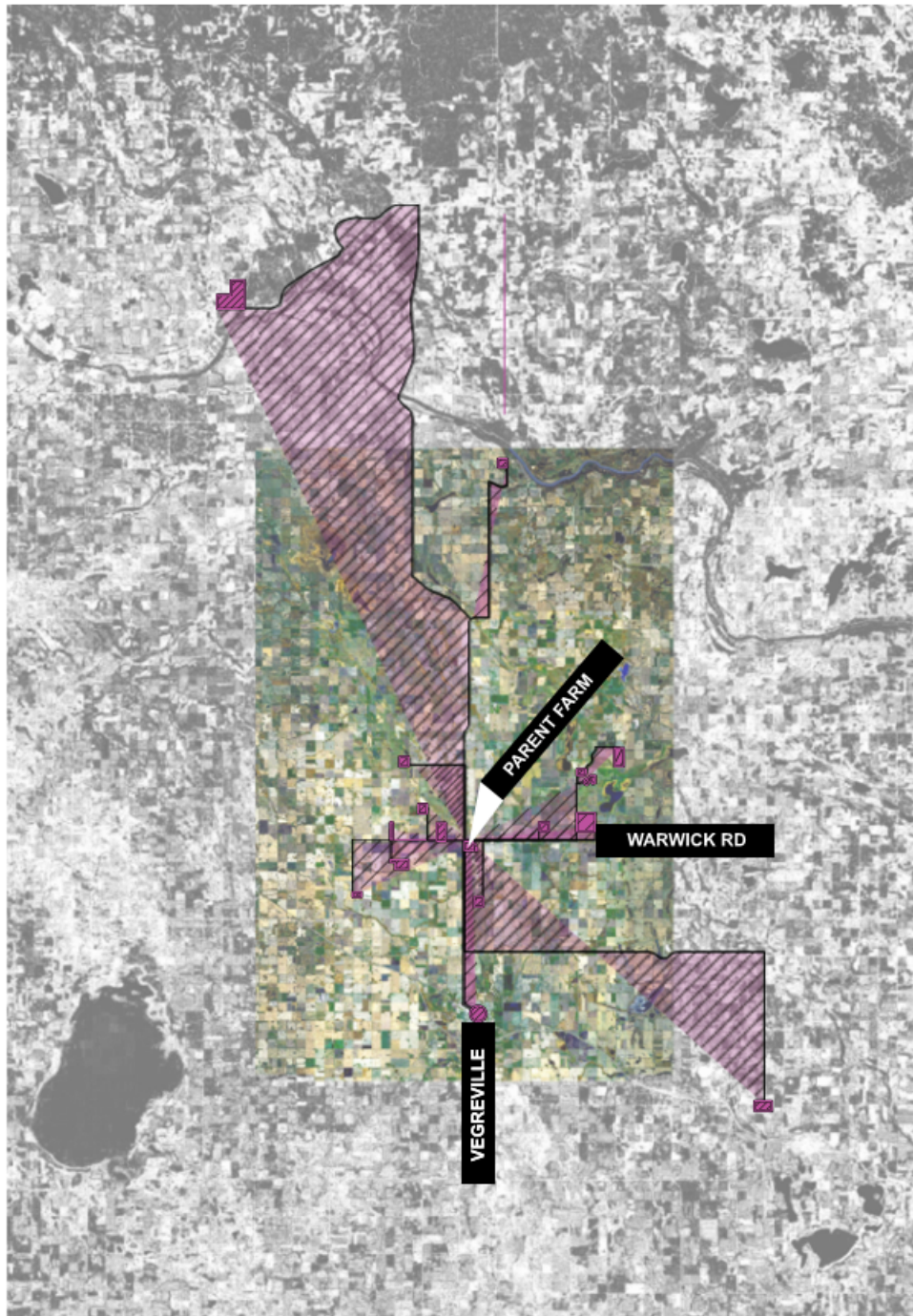

The Parent Farm Process in Rural Landscape.

The extent of the Parents influence through the agricultural process. Distinct sites of activity and association arise within the vastness of the rural landscape.

occupation and strengthen the identity of those individuals already situated in the rural landscape. What is needed are new ideas of the agricultural process and a modernization of the rural lifestyle to re-kindle interest and stewardship of generational family farms.

Value Add Process_Work

The farmers production cycle is a result of their knowledge and manipulation of the natural and manufactured systems at their disposal. When considering the practical model of a farm system, the farmer is conscious to utilize system outputs (waste) and return them as inputs back into the system (fertilizer). What becomes apparent is the ability of the farmer to become entrepreneur and create a quality product of high demand at minimal cost - described as the value-add process. This ultimately means that the farmer has potential to develop a sustainable and efficient agricultural process that is profitable to the farm and community.

However, the limitations of industrial agriculture prohibit this control in today's farms as seed crops are sold as the intellectual property of agri-business conglomerates like Viterro. These corporations demand increased chemical inputs to maintain profit margins and continue to marginalize the family farm model. More and more, the centralized food system places risk and demand on rural landscapes at the detriment of the communities. Wherein the province had once established itself as a global producer of quality agricultural products, this good name is dirtied as federally operated terminals indiscriminately mix high and low grades of cereal grain product to a base quality for export. This has resulted in the decreased sale and export of grains

Christie Lane Farms - Est. 1988

Phases

- 1988 - Weiss Mechanical Services est. , 40'x60' Mechanical Service Shop built, 2-4 vehicle capacity
- 1990 - Post & Beam Cattleshed built
- 1993 - Cattleshed destroyed in fire and Rebuilt
- 2010 - 60' x 120' Mechanical Service Shop extension, 8-12 vehicle capacity, Coal shed and Coal Furnace installed
- 2012 - Heated garage, Mother-in-law suite and farmhouse expansion completed



- Farmhouse
- Producer programming
- Livestock programming
- Storage programming
- Neighbour building
- Garden / Fruit Orchard
- Feedstock storage area
- Productive landscape
- Road
- Fenceline



Parent Farm Landscape.

The Parent farm leases 80 acres of farmland which separates the generational farm from HWY 857 to the west. The proximity to a highway and the rural community of Warwick makes those 80 acres an ideal site to define a *genus loci* for sustainable agricultural process.



Typological Anchor
- Generational
Farmhouse

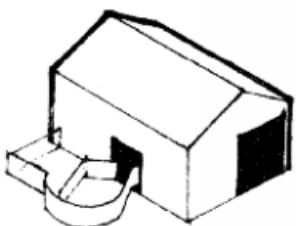

Typological Anchor-
Agricultural Program

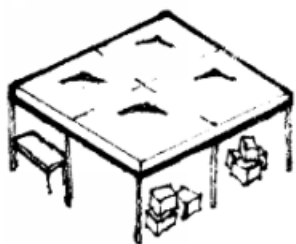

Value-Add Process
- Mechanic Shop &
Community Network

for Canadian farmers, and is a red herring of an apathetic industrial economy. This devaluing of the farmers product is referred to as the Clone Cycle, "the ability to provide innumerable iterations of the same moment[:]...[t]he value of each individual component or process is rendered worthless in comparison to the whole."⁴⁹

As such, the lone producer must adversely deliver the best product possible. The value-add process in the generational farm does not begin or end with a product, but is a way of life - the farmer faithfully building a family operation over time. New technologies and agricultural techniques are systematically researched, tested and implemented within the operation as the farmer optimizes their system. Incrementally, the farm flourishes at the hands of the family as the children learn and contribute to the agricultural process, value-adding to their identity.

Of course, like any community, collaboration is mutually beneficial and farmers develop new knowledge and confirm old through the unique social and cultural networks which link the community. Distinct moments in the rural landscape are opportunity for conversation, and occur most often at common work sites. The grain elevator, the seed plant, the John Deere dealership are all interstitial events in the farmers daily cycle which contributes to his understanding of community.⁵⁰

49. Tyler Dixon, *Exodus: The Disappearing Rural History of Alberta*, 27.

50. Janelle Fillion describes these 'opportunities' in her MArch dissertation, *Industrial Commemoration: A Grain Elevator Prototype for Economic Development in Rural Manitoba*, highlighting their potential as social and cultural nodes for architectural programming within the rural landscape.



- ▲ Building Access
- Circulation of Producer
- Circulation of Livestock
- Homestead
- Service Building
- Storage Structure
- Livestock Enclosure
- Livestock Use by Season
- Producer Use by Season
- ▨ Crop Harvest Storage
- ⊕ Seasonal Equipment Storage
- ⊕ Garden
- ⊕ Greenhouse
- ⊕ Foliage
- Season
- Year Round
- Winter
- Spring
- Summer
- Fall

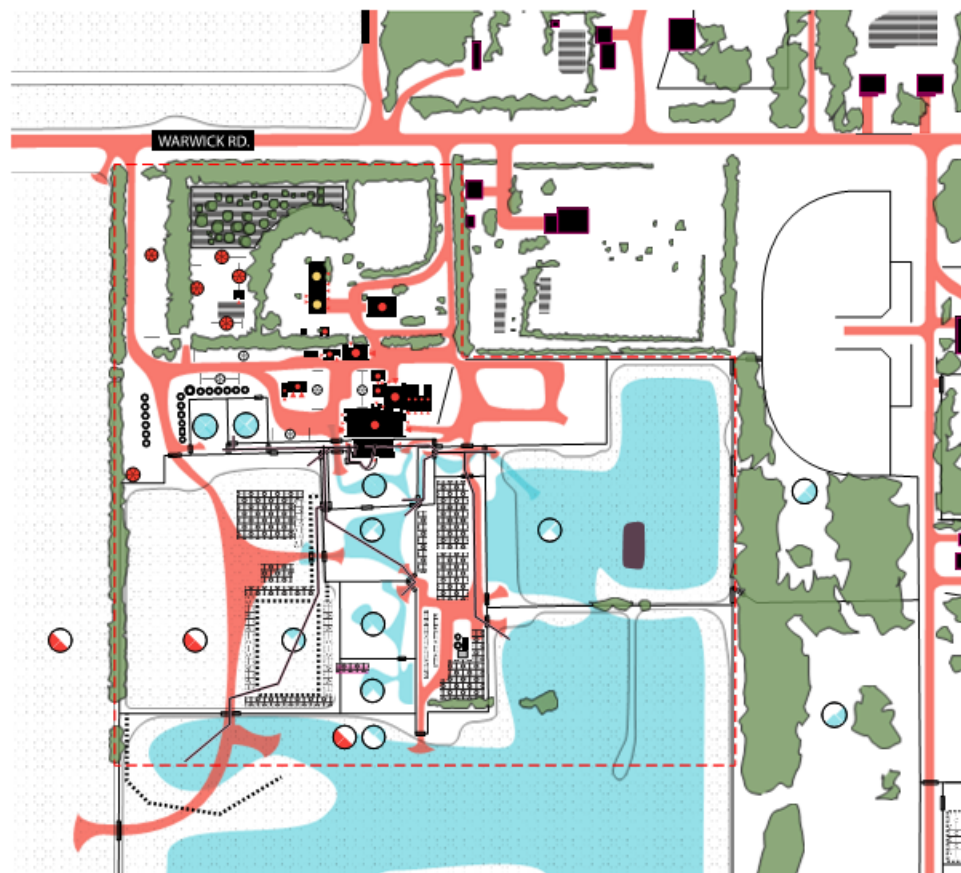

0 m 125 250 375 500

Diagramming the agricultural process of the Parent Farm and the seasonal programming of the productive field.

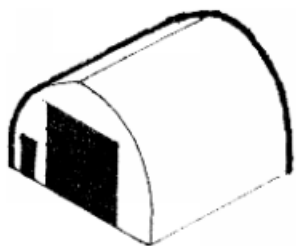

Typological Anchor -
Equipment Storage

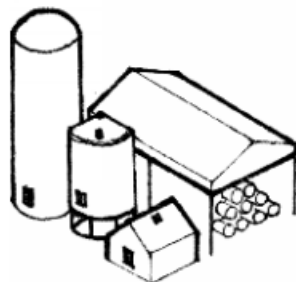

Typological Anchor-
Product Storage

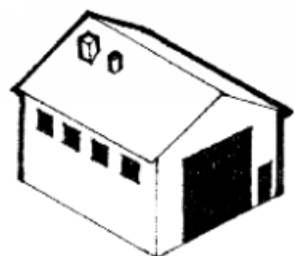

Typological Anchor -
Value-Add Program

If the architecture is to be competently integrated into the rural landscape, the architect must be strategic in developing local networks of shared identity. Many forms and systems have been developed to assist the homecoming of industrial agriculture into the rural landscape. The challenge of design is re-imagining how the rural landscape assists the homecoming of producer and consumer. An important concept of the agricultural process is ownership, and this idea of ownership must be taken above the level of individual farm - to community - wherein the urban consumer can directly interiorize the rural landscape as experienced by a rural producer.

The Parent Farm

Today, the 88 acres my parents purchased in 1988 for \$88,000 is valued over \$600,000. The initial 88 acres stands as the family homestead, but extends to an additional 600 acres spread across three counties; a networked landscape cobbled together through community relationships. From the homestead, the farmer organizes his labours and stores his efforts, but must travel farther and farther to sufficiently operate their farm process. As land is the primary requirement for any farm operation, it is often contested amongst local farmers as they aggressively compete for greater productivity.

Christie Lane Farms (CLF) is owned and operated by my parents and has grown in correspondence with the surrounding agricultural community. My father, an industrial mechanic, understood the need to diversify the income streams into the farm, so that the economic and environmental conditions affecting the farm operation

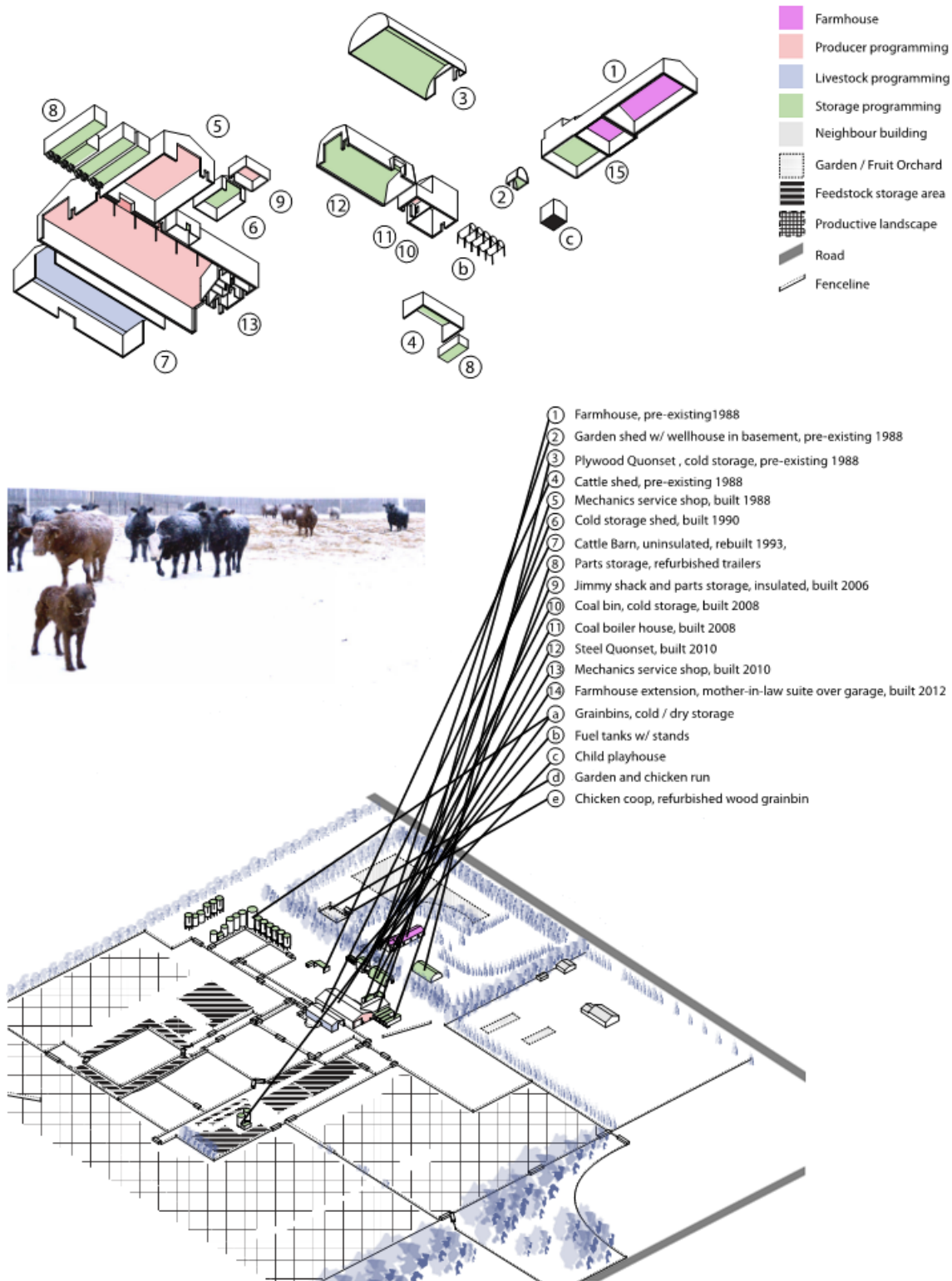

Parent Farm and the Configurative Process.

Diagramming the built form of the Parent generations' agricultural process. Structures are modularized, and programming is a determinant of pre-existing associations. The only resemblance of the Grandparent process within the Parent farm is observed of the mechanics service Shop, the Parents value-add process.

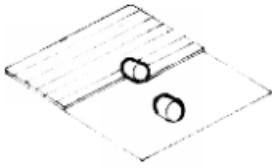

Agricultural Process -
Productive Field



Agricultural Product -
Cereal Grains



Agricultural Product -
Animal Feedstock



Agricultural Process -
Beef Cattle



Agricultural Product -
Meat Foodstuff

could be mitigated by a secured income. Likewise, my mother trained as a lab technologist and commutes daily to Vegreville where she works in the hospital. Together, my parents have worked tirelessly to build a lasting farm operation, working dual careers, a common practice of any generational farm. As industrial agriculture relies heavily on mechanical inputs, my fathers skills as mechanic and his self interest in farming has made his trade service a pillar within the agricultural community.

What is important to remember is why we act and the significance of that action. Beyond a mere occupation, the farmer is resilient in his efforts to be rooted in the landscape for its natural appeal, bolstered by the collective identity of the productive rural community. When analyzing the value-add process of Weiss Mechanical Services, it is clear that built form and scale are regulated by the industrial machine repair process - the interchangeability of cloned parts and the precise repetition of process requires a cloned building typology.

The agricultural buildings of Christie Lane Farms replicate the same physical attributes as the mechanics shop, however, they are developed as uninsulated, utilitarian structures because the agricultural process is inherently exterior. It becomes obvious that agricultural process is considered secondary to the industrial process; reflected by the producers investment into the interior condition of the industrial space, and thusly, their indifference to an industrialized agricultural aesthetic. If this is a common condition of the generational farm, then consumers will associate the rural landscape as industrialized, and thusly,



The Value-Add process of the Parent farm seamlessly integrates into the agricultural process of the generational farm. Agriculture becomes Industrial.

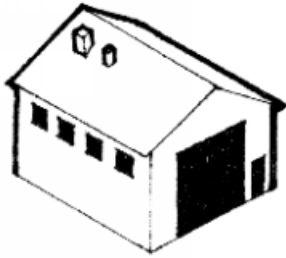

Rural Lifestyle -
Value-Add Process

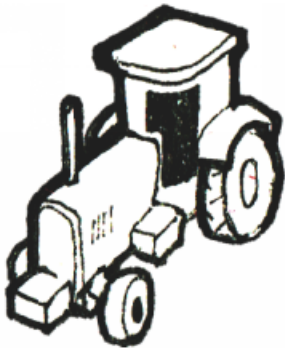

Rural Lifestyle -
Mechanization

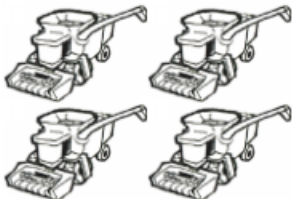

Rural Lifestyle -
Multiplicity

the agricultural process disappears from consumer view. The cloning cycle that is inherent to industrial agriculture has allowed the industrial shell to permeate the rural fabric, and has significantly changed the identity of the Parent generation. A series of forced concessions by generational family farmers allowed for the incremental establishment of the industrial institution within the rural landscape, contributing to apathetic sentiments of the agricultural process.

The lifeless form of the industrial shell is irrelevant to natural landscape process, yet flourishes for its economy of scale and flexibility of program. This evolution of the agricultural built form occurred in response to the intense mechanization of the agricultural process and formal programming is guided by vehicular traffic. As farmers and rural residents maintain their present farmsteads, they draw from a common experience of building knowledge, revealing how building convention is disseminated across the rural landscape given the proper attributes. What this means to the design process, is that agricultural building form must idealize the principles of sustainable economics and environment if it is to be replicated at other sites.

What ultimately defines the farmstead is the farmhouse, as it becomes the epicenter of the rural producers Live/Work/Play cycle. In the case of Christie Lane Farms, the farmhouse is a simple, bungalow-style, log home and reveals how the builder saw utility in a modern home design, but chose to implement natural materials that could directly associate to the rural lifestyle. The farmhouse becomes the ultimate social and cultural influence on the Offspring



The utility of the space frame within the rural landscape.

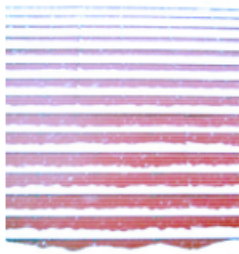

Sheet metal is the preferred material of the industrial agricultural process.

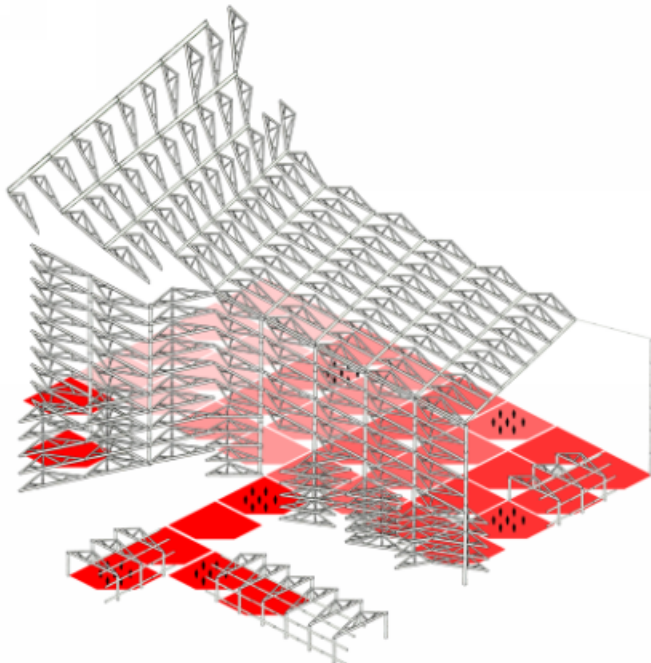

Interpreting the Industrial Shell

The endless programming of the space frame typology and the modular element.

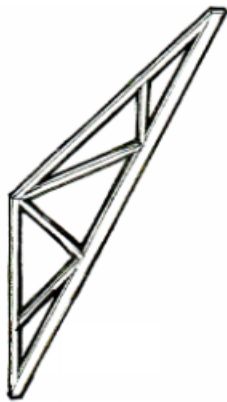

**Modular Element -
Wood Truss**



**Modular Element -
Wood Beam**



**Modular Element -
Wood Column**

producer through the Live cycle, as it becomes the blueprint for the Offsprings own agricultural process. Through time, new additions and necessary renovations to the farmhouse respond to family growth and technological innovations that provide desired residential comforts. Ultimately, the concept of the generational farmhouse is to live in rural landscape - in the absence of urban comfort. The character of the rural producer is self-sufficiency and symbiotic growth, principles absent from the industrial agricultural process.

The Rural Experience_Play

Given the distance between farmsteads, the 'in-between' space becomes quite evident, and the natural landscape dominates the experiential procession of the traveller through the rural fabric. In essence, the rural landscape is not defined by built form, yet built form is how a traveller would measure passage through the landscape. Therefore, the buildings act as monuments to way finding and establishing local identity.⁵¹ In that a grain silo denotes grain storage and grain production, the producers residence denotes lifestyle and a continuous thread can be drawn between form, process and landscape. However, what is the identifiable message of the rural monument as recognized by travellers driving past, experiencing the rural landscape in their peripheral vision and from within a isolated box?

In theory, the resurgence of generational family farms, providing value-added agricultural products

51. Tyler Dixon's MArch thesis, *Exodus: The Disappearing Rural History of Alberta*, describes the experience of the rural landscape as the intersection of horizontal and vertical monuments, where built form denotes the local agricultural process and shares identity through typology.

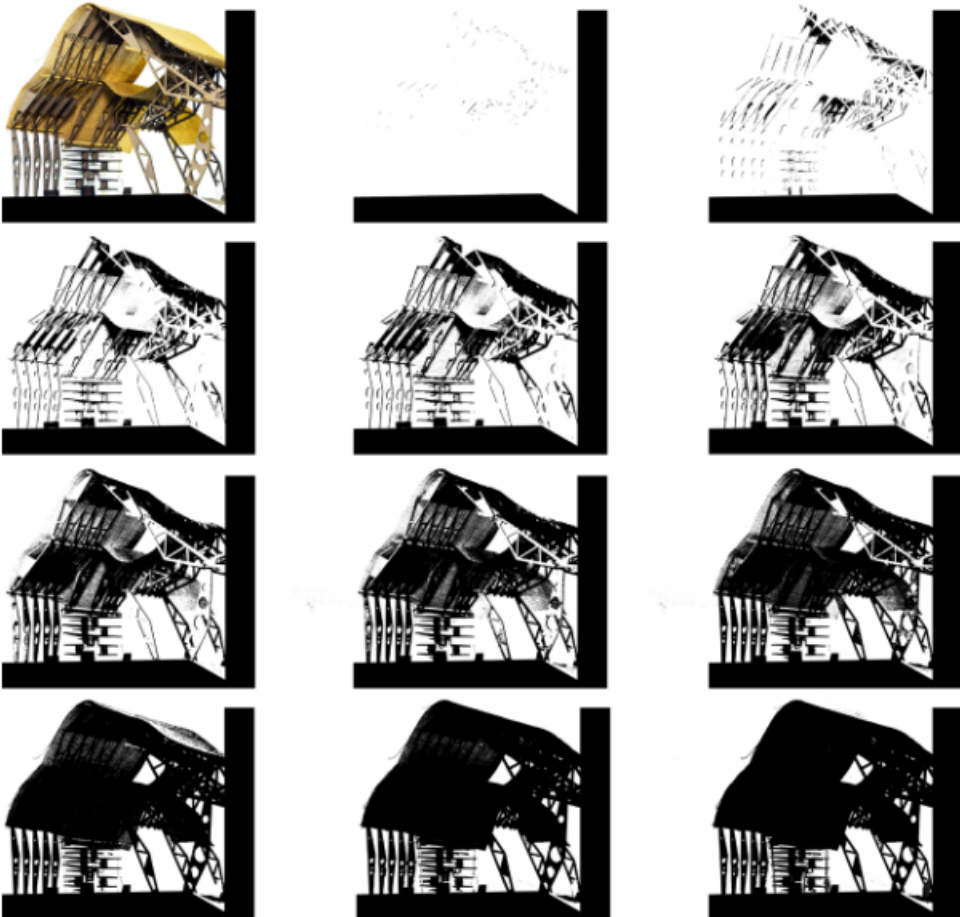
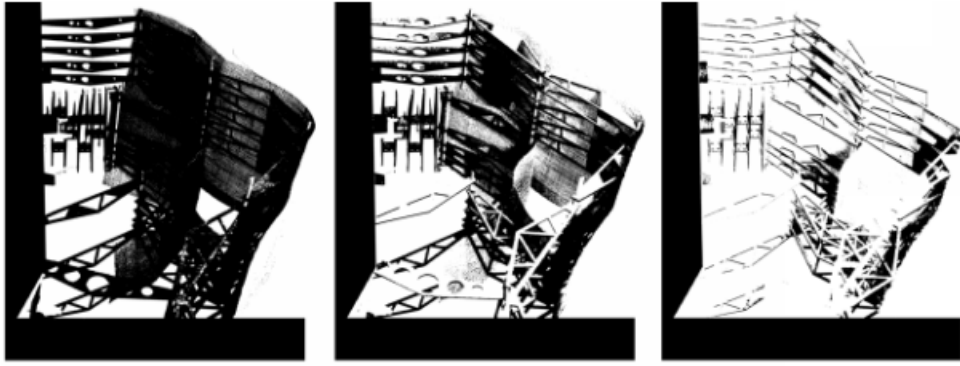

Farmstead.
Incremental materialization and validation of the agricultural process.

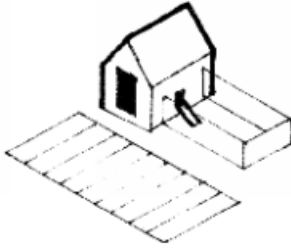

Typological Process -
Agricultural Landscape



Typological Process -
Primary Agricultural
Product

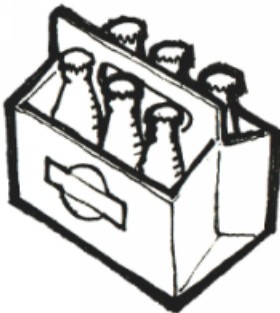

Typological Process -
Value-Add Product

developed for local communities, could create a sustainable and economical model of rural communities. The beauty of the agricultural process is that an abundance of valuable, commodified products can be grown using natural energies and manual labour. Given that a vegetable is a medium of the chef, and the dish is the interpretation and orchestration of the medium - the food product can create a unique, or reproducible, experience for the consumer. We understand the rural producer as provider of the basic elements we structure our world from and, ultimately, as being subservient to the consumer demand.

What is required of the architecture is a new medium from which rural producers can initiate their value-add process in response to local community needs. As well, the architecture must re-imagine Play within an industrialized rural landscape by focusing on the rural producers notions of homecoming. By integrating re-imagined systems into existing systems of production and consumption, uptake of the new medium becomes widespread. This in turn challenges the architect to select a medium of construction and design that can seamlessly integrate into existing landscapes by adapting new typologies to a vernacular agricultural process. The vernacular built form of the industrial rural landscape reveals a simple template from which new architectural typologies generate, but using a building medium harvested from the productive landscape. As the intention of a resilient community requires the generational habitation of the rural landscape, the imagined system must look to the Offspring Farm to exhibit the desired attributes of a sustainable rural community.

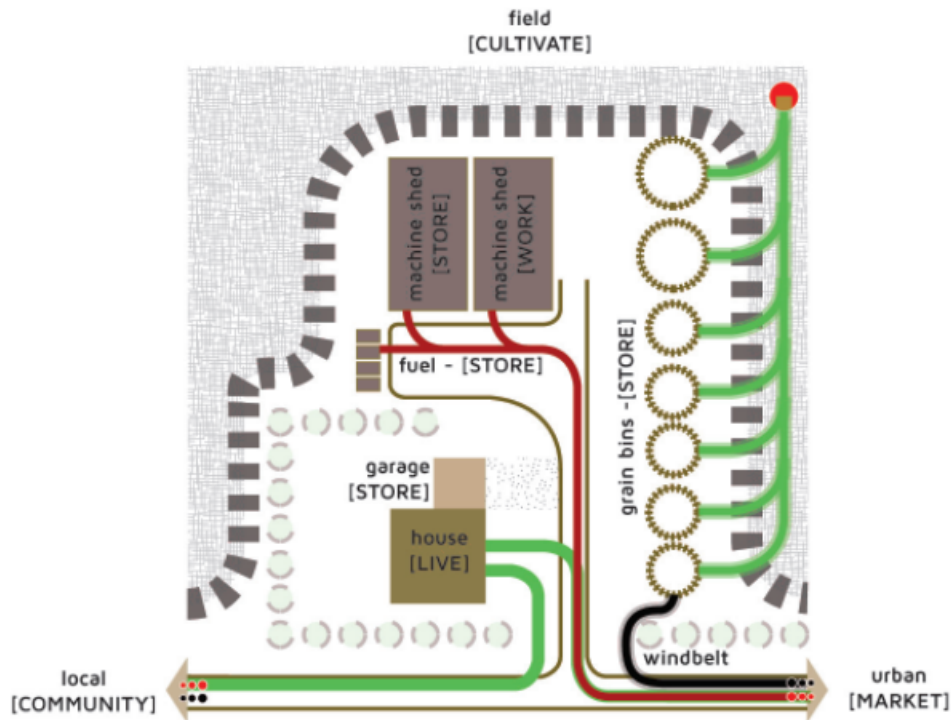

Modernism and the Industrial Agriculture Process.
 Diagramming the industrialized farmstead as it typically exists in Alberta's rural landscape.
 A Resilient Agricultural Process.

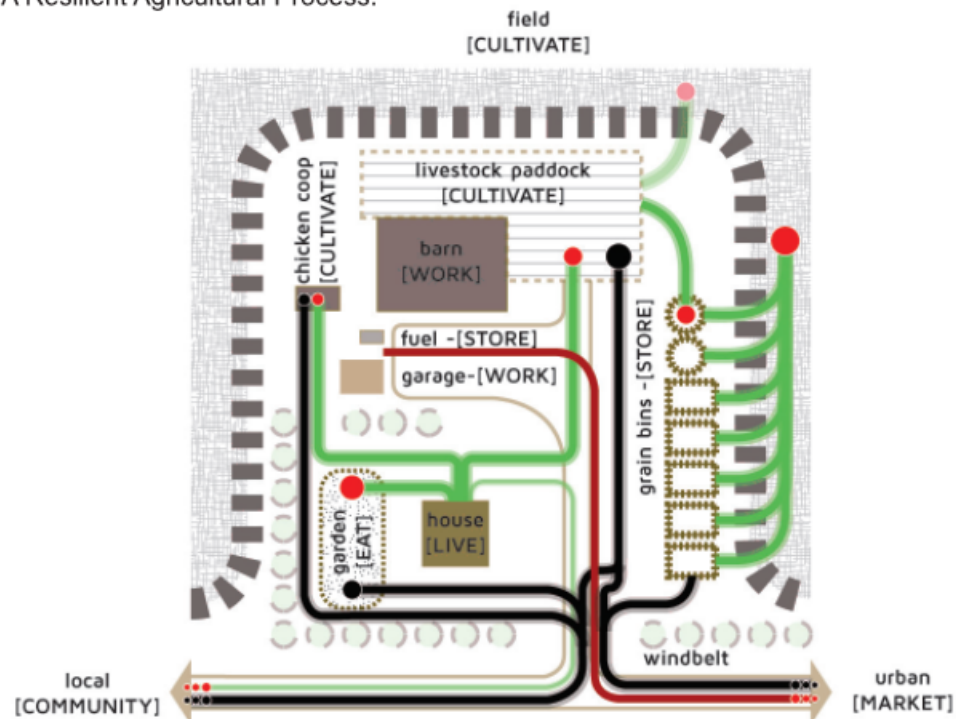

Diagramming the generational farmstead that demonstrates food resiliency for itself and the local community..

The Offspring Farm

At this point in time, my parents continue to farm in Warwick, but look to their offspring to take on their efforts. My oldest sister has already committed to the rural lifestyle, purchasing a local farmyard and 160 acres of cropland 5 miles east of Christie Lane Farms. The previous owners maintained a generational hog farm and built an agricultural process focused on living in the rural landscape. My sister works in my fathers mechanics service as an parts and service manager, using her free time to maintain her farm.

During the harvest season, the Offspring utilizes her experience from the family farm to contract as an equipment operator for local farmers - an extra hand in the field and extra funds towards the farm. The Offspring farm does raise any livestock, but rents the productive landscape to the Parent Farm operation. As the Offspring defines their lifestyle in the cycle of the generational farm, they stand to set a new standard of rural process. As the Offspring becomes Parent, they synthesize learned experience with the experience they desire for their Offspring. Like many of my family raised in farm culture, we desire new lives in the homes we love. The home of the farmer does not end at the farmhouse porch, or the driveway, but extends to the productive landscape we grow potential from. What this means is that generational family farm is a constant value-add process of the Live cycle, and is taught from Grandparent, to Parent, to Offspring.

Derived from the rural typology, the built form of the Offspring Farm is minimalist in that only a few basic structures are necessary to the agricultural process. A stand-alone plywood Quonset functioned as equipment

Christine Weiss Farm - Est. 2012

- Phases**
- 2012 - Property Purchased
 - 2017 - Small Barn Raising
 - 2019 - Rural Community_Phase 1
 - 2022 - Rural Community_Phase 2
 - 2024 - Community Hall Raised

- Farmhouse
- Producer programming
- Livestock programming
- Storage programming
- Neighbour building
- Garden / Fruit Orchard
- Feedstock storage area
- Productive landscape
- Road
- Fenceline

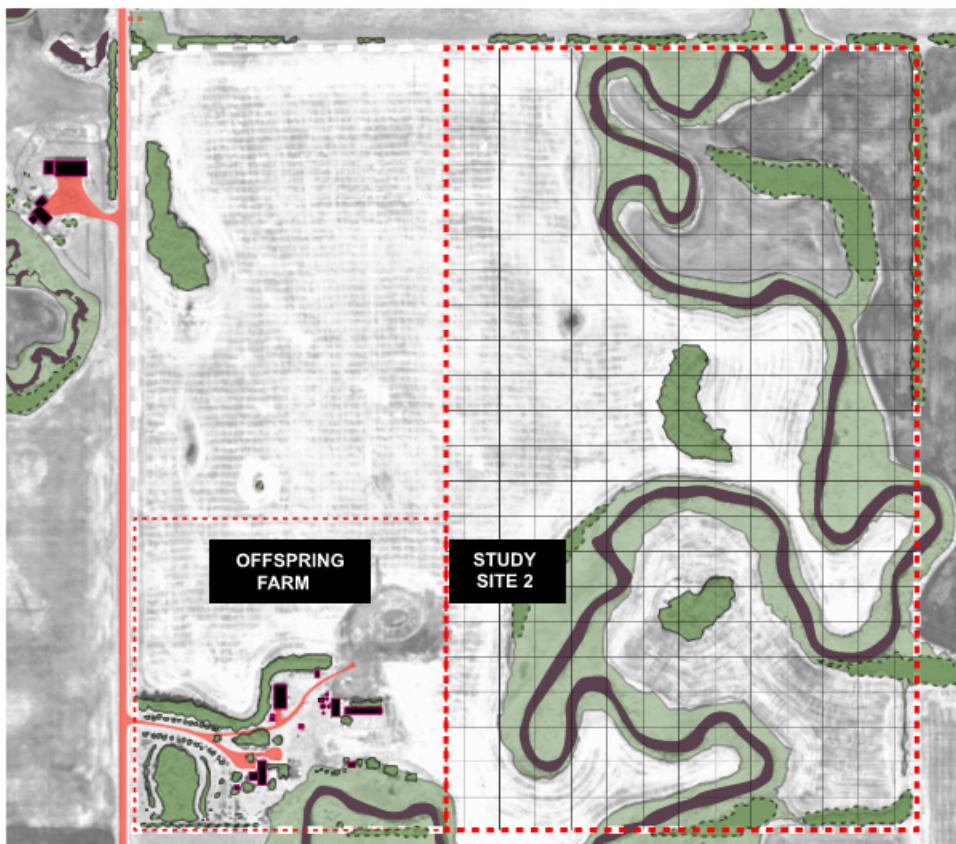

Offspring Farm Landscape.

The Offspring farm is a standard quarter section (160 acres) consisting of a generational farmhouse, a non-operating farmyard, and a productive field; rented to the Parent farm. This site demonstrates the majestic beauty of the prairie landscape become rural, offering vistas onto rolling hills and river valley as they intersect the agricultural process.

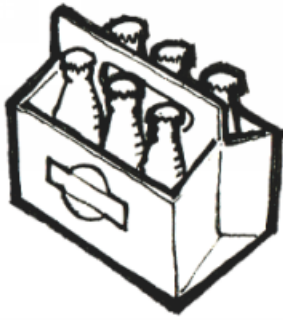

Rural Lifestyle -
Social Experience



Typological Anchor
- Generational
Farmhouse

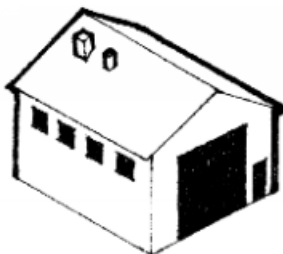

Rural Lifestyle -
Value-Add Process

storage and service shed, bordering the western edge of farmyard and separated from the productive landscape by a wind belt. The eastern edge of the farmyard is defined by grain bins for feed storage and the structures of the hog operation, the built form of the local agricultural process. A 24ft x 32ft heavy concrete foundation, formerly a sown barn, and an 16ft x100ft open-faced, lean-to barn of simple post and beam wood construction defined the livestock experience and reciprocated the local producer process. If we understand the lean-to shed as a utilitarian structure for shielding livestock against severe weather conditions, then orientation of the agricultural built form is evidence of the producers response the rural landscape micro-climate

The farmyard between the Quonset and hog barn was necessary to organizing the daily agricultural process and is defined at its eastern edge by the grain silos. Again, the typological farmyard is defined by the circulation and service of the technology necessary to the agricultural process. Only surfaces that require constant maintenance utilize resilient materials such as concrete, wherein typical circulation throughout the farmyard is defined by gravel path, or, is delimited by an inexhaustibly programmed open field.

At the southern limit of farmyard, adjacent to the ravine, stands a hand-hewn, mud-patched, log barn that served a much older farmstead. Seemingly, a natural aesthetic that becomes the generational farm is the adaptive reuse and abandonment of built form throughout the evolution of the generational agricultural process. Over time, as the agricultural process evolves and technology



- ▲ Building Access
- Circulation of Producer
- Circulation of Livestock
- Homestead
- Service Building
- Storage Structure
- Livestock Enclosure
- Livestock Use by Season
- Producer Use by Season
- ▨ Crop Harvest Storage
- ⊕ Seasonal Equipment Storage
- ⊗ Garden
- ⊠ Greenhouse
- Foliage
- Season**
- Year Round
- Winter
- Spring
- Summer
- Fall

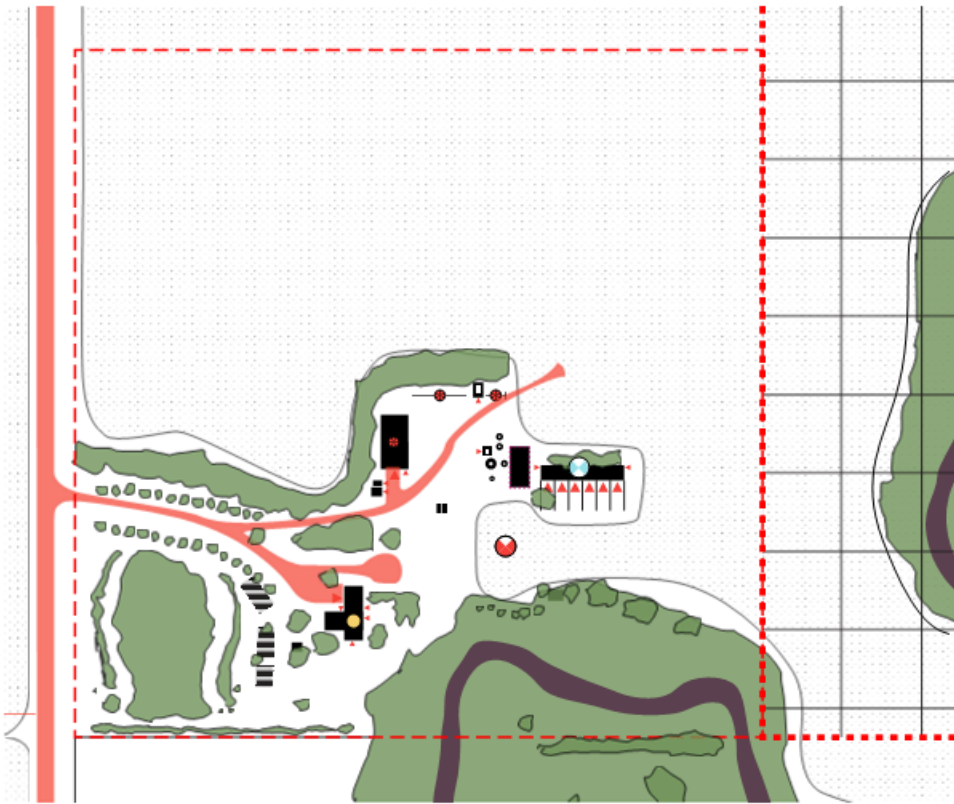

Diagramming the agricultural process of the Offspring farm and the seasonal programming of the productive field. As the previous owners of this generational family farm retreated from the agricultural process, the focus turned to lifestyle, setting a precedent for the desirable rural dwelling. The Offspring farm reveals a bare composition for the agricultural process, yet retains a field of potential.

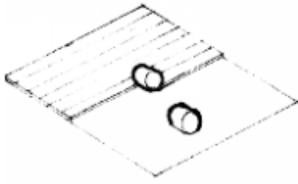

Agricultural Process -
Productive Field



Agricultural Product -
Cereal Grain



Agricultural Product -
Animal Feedstock

is replaced, the technology becomes relic and lends to the rural aesthetic - the virtue of steel. The case of antique technology is not the case of the antiquated built form, wherein disused structures are left to natural cycles of decay. If a new building typology is to signify a resilient agricultural process, the architecture will require a material that can exist as long as the generational farm requires, yet can be recycled when necessary.

The Offspring farmhouse is a custom home designed and built for a generational family farm and reveals a clear manifestation of what it means to Live in the rural landscape. Organization of built form on the Offspring farm is through the articulation of prospect onto the rural landscape and the agricultural process. The farmhouse is sited at the highest point on the site and removed from the gravel road via a long gravel driveway. Overlooking a river coulee that cuts through the landscape south of the farmhouse, a significant elevation change occurs between the edge of the farmhouse and the river below providing a dramatic vista of the natural prairie landscape.

Large garden beds were developed at the edge of the tree stand that screens public road from the private yard to support food resiliency. The value of this yard space reveals opportunity for the generational farm to sustain itself directly from the landscape through the planting of social and cultural activity that supports a rural lifestyle. As greater bonds form between the urban consumer and rural producer, the Offspring farm becomes second home for visiting friends and stewards who desire an identity as resilient and self sufficient as the generational farmer. More

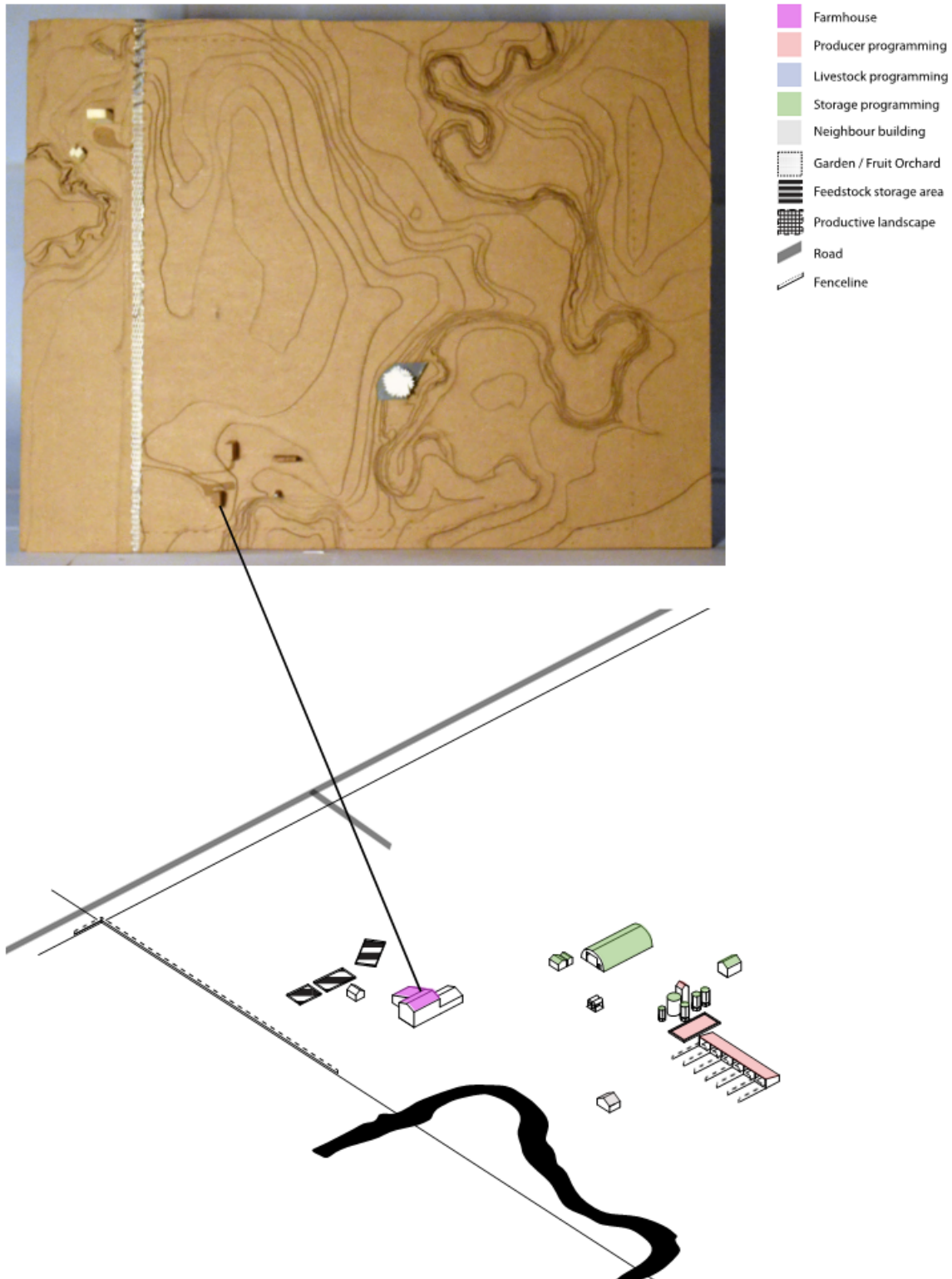

Offspring and the Configurative Process.

Diagramming the resilient built form of the Offspring farm to anticipate future development. Existing built form echoes the Parent farm in that the residence is a configurative structure focused on rural lifestyle and that the agricultural structures resemble the industrial agricultural process.



Rural Lifestyle -
Spirituality of Process

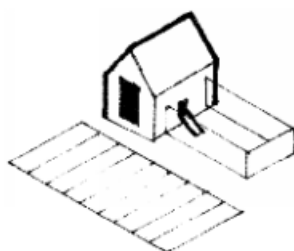

Rural Lifestyle -
Food Resiliency

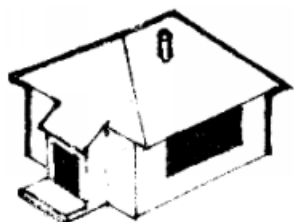

Rural Lifestyle -
Education of Process

than ever, the Offspring farm represents the potential for a new generation of social and cultural cohesion via the productive rural landscape.

As my sister begins to define her role in the community of Warwick, she sees great potential in the rural landscape she inherits and the farmstead she inhabits. Significant repairs and maintenance are required on such a large property, and lead the next generation of rural producers to adopt urban concepts of shared dwelling and skill-building. The notion of rural density is not a new concept, but occurs naturally as ideal conditions for lifestyle attract like-minded individuals and thusly, pocket communities are formed. Given the complexity of establishing a new farm operation in today's rural landscapes, this leads the architect to consider how the next generation of producers may require cooperative dwelling and service spaces, developed incrementally, as need and prospects grow. The design objective of the Offspring farm thus becomes to develop a sustainable model of the agricultural community that entrenches the generational farm within the rural and urban context.

Agro-Architecture_Design

To the immigrants especially ... language was more evident as a medium - a medium that could be shaped and reshaped - than as a social custom ... Over a wide and diverse range of practice this emphasis on the medium, and on what can be done in the medium, became dominant.

- Raymond Williams⁵²

As discussed, the generational family farm operation

52. Farias and Bender, *Urban Assemblages: How Actor-network Theory Changes Urban Studies*, 273.

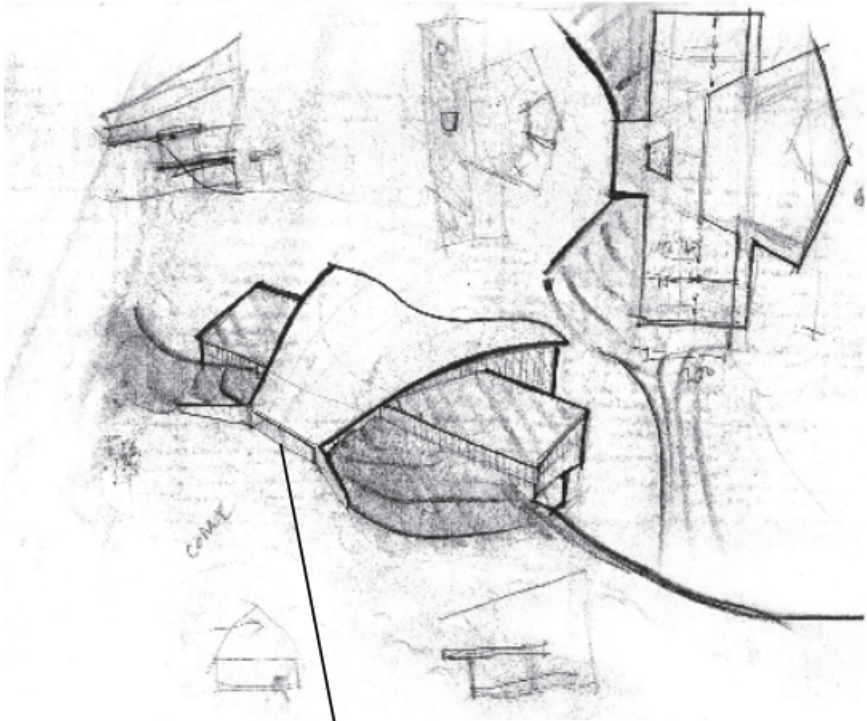

Sketch of the new Community Hall.

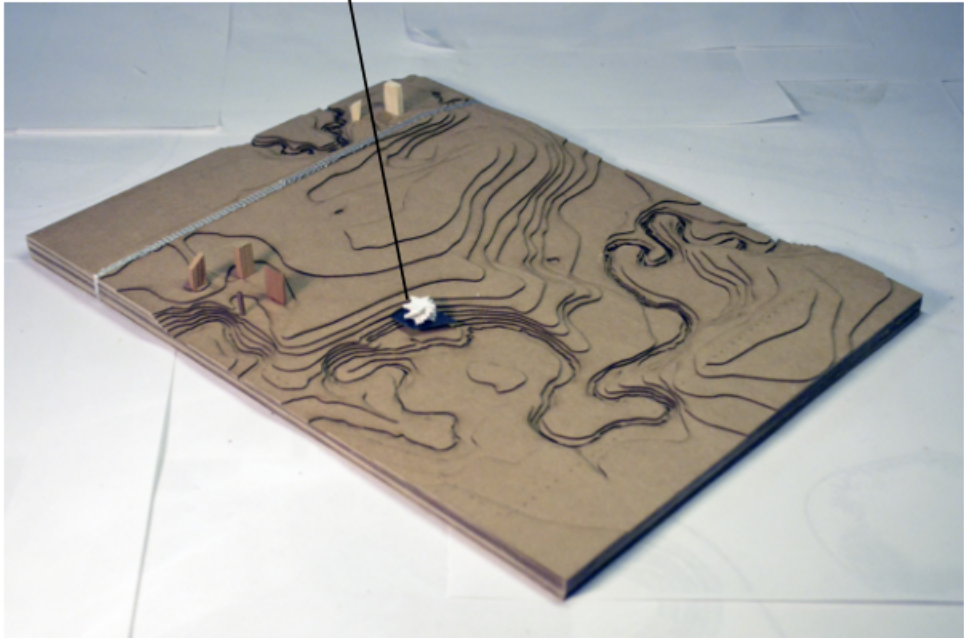

Sketch Model of Offspring Farm and ideal site for the new Community Hall needed to make the new community resilient. Community members maintain the Hall for the basic social and economic services for the Hall attributes to the community -- a reciprocal lifestyle germinates in the rural landscape.

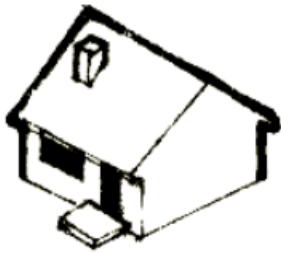

Rural Community -
Generational Residence

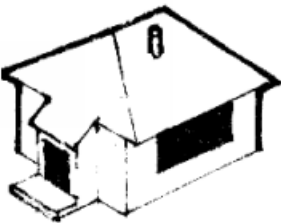

Rural Community -
Skill Development



Rural Community -
Community Hall

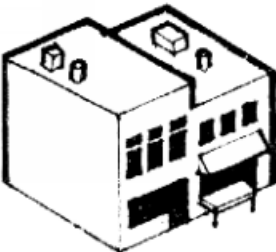

Rural Lifestyle -
Community Farmgate
Store

is not a mere imprint on the landscape, but a direct expression of a consequential value-add process wherein the family producer is the medium for a sustainable agricultural process. The built form which nurtures this process is critical to the operation, but occurs as a conglomeration of predetermined technologies arranged through the intervention and skill of the rural producer. Case studies of the Grandparent, Parent, and Offspring farm reveal three farm typologies developed at different stages of industrial agricultural practice; each demonstrating new adaptations of the generational farming process. To describe the common thread between the generational family farm in association to the Warwick community, and, by extension to the collective identity of the Canadian prairie farmer, I quote the words of Raymond Williams; '[it is] a community of the medium; of their own practices.'⁵³

As the intention of the design process is to revitalize rural communities by creating stronger connections to the consumer, then the architect must begin to map the intersection of the rural and the urban process and define what the medium shall become. What the architecture should reveal is a building convention that speaks to the commonality between the urban and rural notions of homecoming, yet defines a sustainable and exportable practice of the re-imagined Live/Work/Play cycles.

When comparing the adaptations of the urban and rural built form since the post-modernist movement, it is clear that residential, commercial and industrial architecture evolve at different rates in concordance with the

53. Ibid., 273.

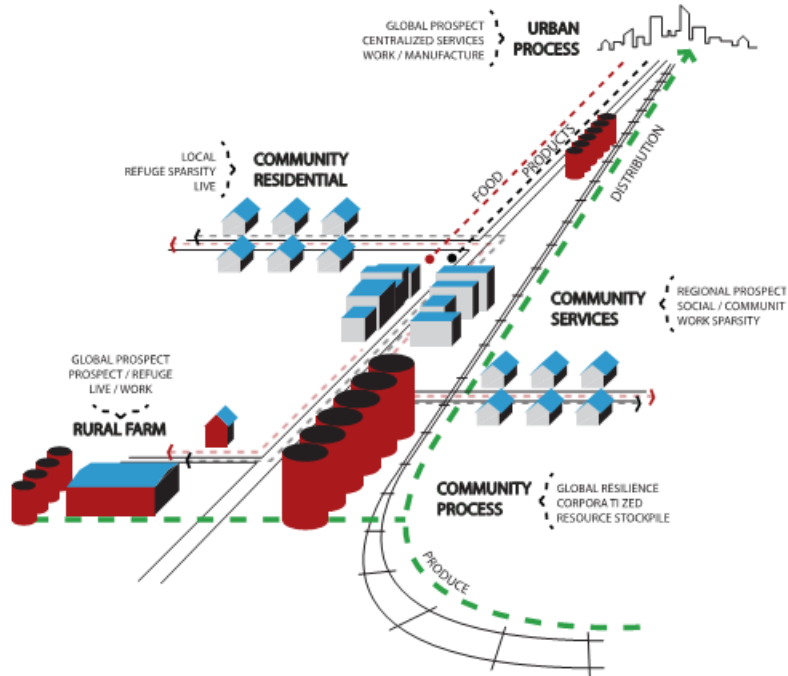

Modernism and Industrial Agriculture Process.
Diagramming the industrialized rural community.

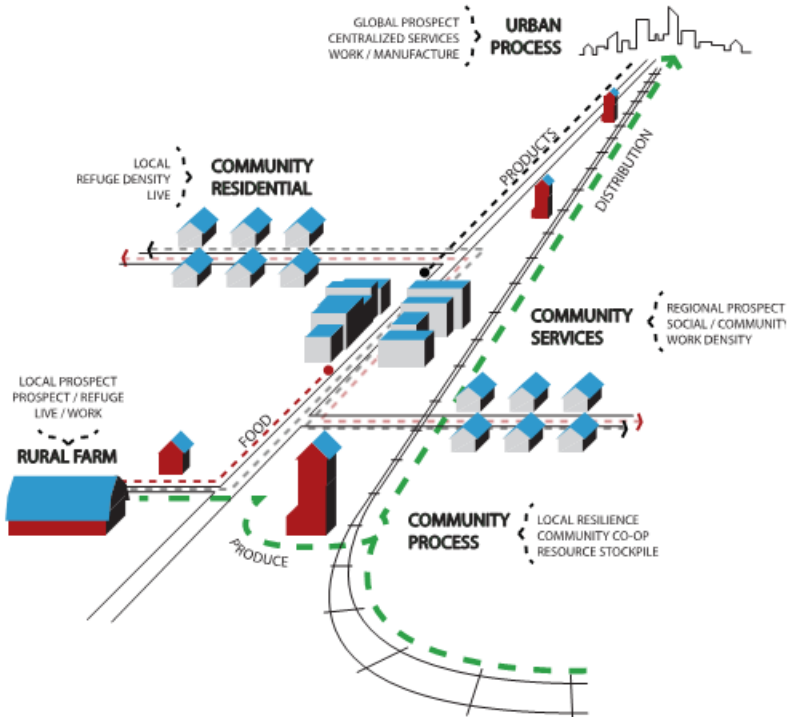

Resilient Agricultural Process.
Diagramming a sustainable rural community model.



Industrial Product -
Hemp Oil



Agricultural Product -
Hemp Seed

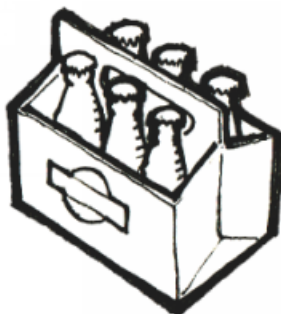

Lifestyle Product -
Foodstuff

anthropogenic development of technology and process.⁵⁴ This is to say that a typical residential form persists throughout the prairie landscape, common to both urban and rural context and suggests multiplicity. We can interpret this principle of multiplicity to be a result of a constant notion of homecoming, or Live, that exists between all individuals, and the result of a material building convention, or vernacular form. A multiplicity of form is again revealed in the provision of the generic residential, commercial and industrial spaces that exist simultaneously in the urban and rural landscapes - a result of common Live/Work/Play cycles.

As urban modes of dwelling change rapidly in response to density requirements, rural modes of dwelling change slowly as a result of an integrated Live/Work/Play lifestyle. Thusly the rural landscape offers a preferred model for architectural design because of the producers self-determined rate of growth. Naturally, the generational farm requires incremental growth of program and structure to supplement a generational built form. The common thread that precariously ties the rural to urban is the Live model, the notion of homecoming. This does not delimit the role of the architect to solely designing for the residential, but should prepare the architecture to elevate the notion of homecoming to the commercial and industrial scales. If the generational family farm is to once again become significant to its urban counterpart, it must reveal how the rural landscape can provide a better consumer experience through the combined Live/Work/Play cycles.

54. Trevor Boddy details the entrenchment of modern architecture in Alberta since its post-war development in his book, *Modern Architecture in Alberta*. The lessons of modern design predicated the industrial shell which has now engulfed the rural landscape.

HEMP PRODUCTION

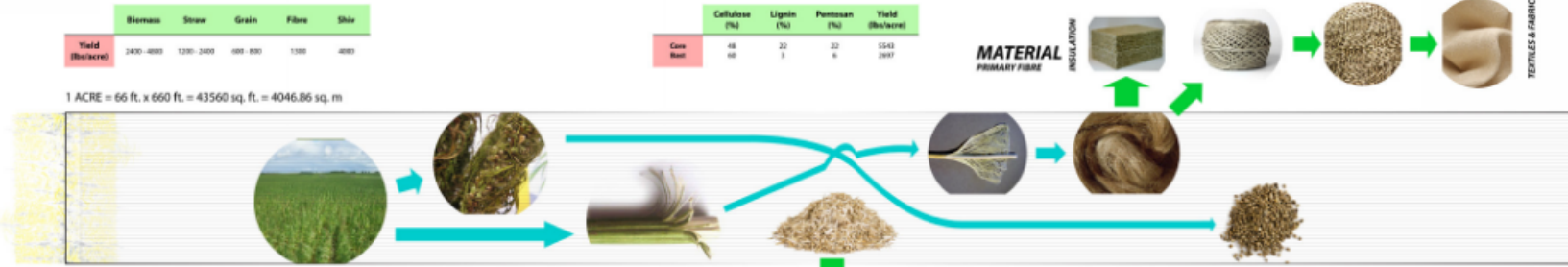

	Biomass	Straw	Grain	Fibre	Shiv
Yield (t/ha)	2400-4000	1200-2400	600-800	1300	4000

	Cellulose (%)	Lignin (%)	Pectin (%)	Yield (t/ha)
Core Bark	48	22	22	1541
Core Bark	48	3	6	2047

1 ACRE = 66 ft. x 660 ft. = 43560 sq. ft. = 4046.86 sq. m

1M3 IN RELATION TO 1 ACRE OF HEMP

THE LOW RISK BENEFIT OF HARVESTING SECONDARY FIBRE IS A LIMITATION TO ITS INDUSTRIAL PRODUCTION, AS WHILE IT IS REGARDED AS THE MOST ECONOMIC, TRAVEL DISTANCE OF SECONDARY FIBRE FROM FIELD TO PROCESSING CENTRE.

Alberta Farm Perspective
To assess the viability of the production efforts, the consideration of a multi-use agricultural product is inherent to the design process. Producers must approach the production process based on access to processing facilities and consumer markets. Dual cropping increases the overall capability of the use cultivated resource, and provides more diversity to local systems.

Hemp Cultivation
The cultivation of hemp requires strict placement of seed within a given area to ensure production growth. A hemp field planted for seed crop requires 100 to 120 plants/m², and fibre crops require 300 to 375 plants/m². This is an advantage for food production and urban systems, in that specific programming determines density. Aside from seedling requirements, hemp is a resilient plant subject to variety, being able with high levels of organic matter yield 6 to 7 and should not be exposed to temperatures below 1°C. Hemp outperforms weeds regarding herbicides for its cultivation cycle, or the subsequent crop in the production cycle.

CARBON SEQUESTRATION

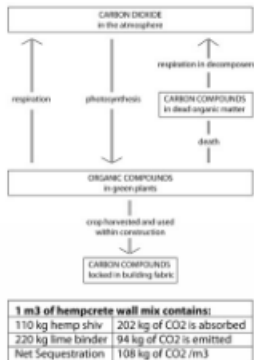

1 m ³ of hempcrete wall mix contains:	
170 kg hemp shiv	202 kg of CO ₂ is absorbed
220 kg lime binder	94 kg of CO ₂ is emitted
Net Sequestration	108 kg of CO₂/m³

Wall thickness (mm)	Wall thickness (in)	U-Value (K/m ² /K)	R-Value (1m ² W/K/m)	RSI Value (0.178)
300	12	0.25	25	4.35
400	16	0.18	33	5.96
500	20	0.15	40	7.14

Hempcrete Composition
Hempcrete is a mixture of the hemp shiv (shiv) and a natural cement lime binder. It is crucial that shiv is thoroughly coated in lime binder to ensure the carbon sequestration. The construction process of hempcrete makes it an easily manufactured brick that local builders can readily adapt to any regional ecology. Buildings designed with hempcrete present new opportunities for energy efficiency and building technologies.

Market Basics
Hemp is employed in a number of consumer markets and can be cultivated to specific consumer demand. The issue being widespread use of industrial hemp products is a lack of accessibility to material processing facilities. The value of hemp-industrial fibre is their potential to create sustainable building products that are locally sourced.

HEMPCRETE CONSTRUCTION



HEMP IN DESIGN



Process of Transformation.
Initial explorations of how industrial hemp manifests within the rural landscape and becomes architecture.

Base Image Source; Hemp Architecture. 2016. "Hemp Architecture Gallery." United States of America: Hemp Architecture. <http://www.hemparchitecture.com/>



Industrial Product -
Woven Fiber



Agricultural Product -
Hemp Fibre



Lifestyle Product -
Textile Fabrics

A New Public Architecture

Given the circumstance of the existing rural landscape, a new public architecture is required to educate consumers of their vital role in the social, cultural, economic and environmental cycles that structure our society. The urban structuralist convention was implemented on a basis of process separation irrelevant to proximity, wherein the urban centres are no longer local, but global. If rural landscapes must operate at global scales, they will not survive; as evidenced by the continued decay of rural communities and growing concerns of food crisis under industrial agriculture.⁵⁵ A return to the agricultural process rooted in landscape would guarantee local networks of production, and could potentially develop new building conventions that disseminate a sustainable mode of living.

Given that generational family farms intrinsically attach process to place, a brief overview of current events happening in the context of the rural community of Warwick reveals a new opportunity for the sustainable agricultural process. Located within the town limits of Vegreville, the immediate urban community that services Warwick, is the Alberta Agricultural Research Council, a multi-acre research and development facility. It is also a branch location of Alberta Innovates Technology Futures, a provincially sanctioned research and development facility that has been developing empirical data on the local production and material processing of industrial hemp. Legalized in 1996

55. Julia Wright's book, *Sustainable Agriculture and Food Security in an Era of Oil Scarcity : Lessons from Cuba*, details the emergence of sustainable agriculture in light of severely reduced access to industrial agricultural inputs such as oil and chemical fertilizer.

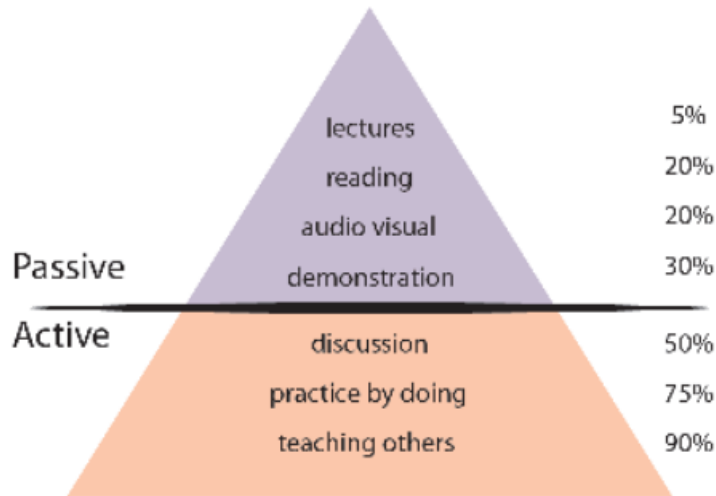

Edgar Dales "Learning Triangle"

Edgar Dales "Learning Triangle" demonstrates the potential of engaging the consumer through passive and active education techniques. It is obvious that the safety of visitors to the farm will prohibit their engagement in certain activities, but develops an intriguing proposition to the development of passive educational environments.

Rural Systems & Consumer Education

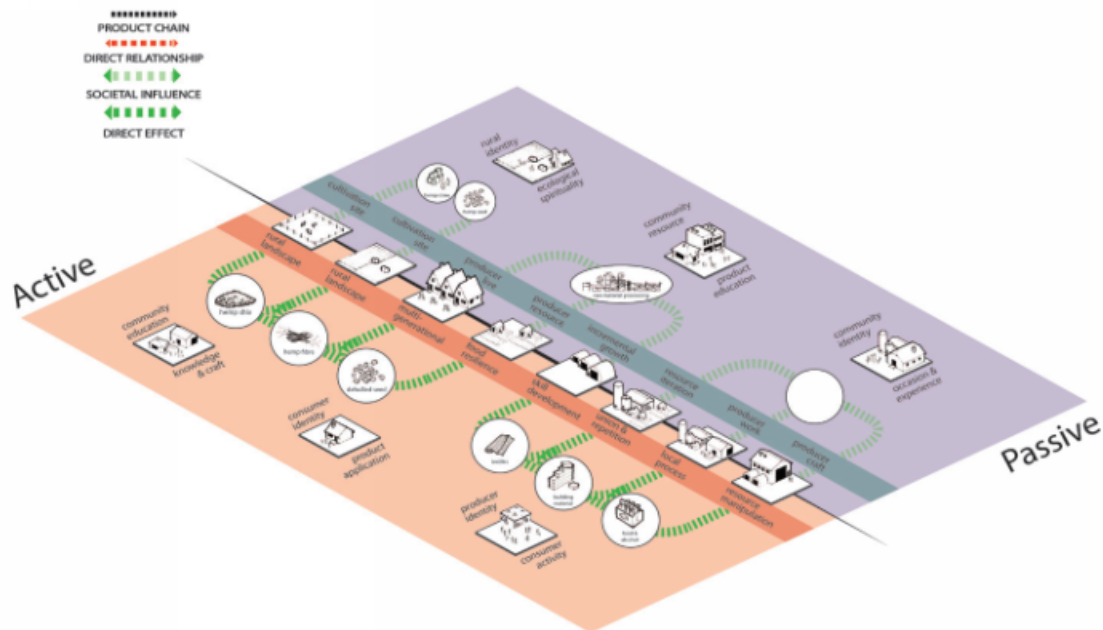

Process of Transformation. Imagining the Consumer Experience through the hemp network to determine consumers learning potential.



Industrial Product -
Hempcrete



Agricultural Product -
Hemp Shiv

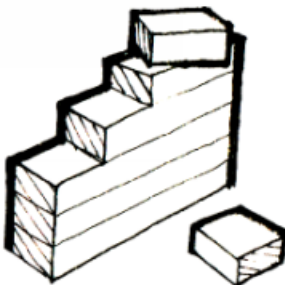

Lifestyle Product -
Building Material

by the Canada's federal government, industrial hemp is understood to be an incredible opportunity for Canadian producers to diversify their agricultural process through the development of biofibre industries.⁵⁶ Growing interest in hemp production is common conversation amongst the rural producers that visit the Parent farm, but the rapid uptake of industrial hemp production in Alberta is only justified through the installation of capital intensive processing facilities.

A brief overview of how industrial hemp can be integrated into the rural and urban lifestyle reveals over 25,000 consumer products developed from the plants seed, the stalks primary fibre, and the stalks core fibre. Historically, the plant occurs naturally in agriculturally productive landscapes, and was utilized primarily for its fibres in common, every day products such as paper. The year that Dupont oils developed its chemical process that allowed paper mills to use wood pulp to make paper, was the same year that industrial hems sister plant was made illegal by the Marijuana Tax Act of 1937.⁵⁷ Although targeted at marijuana, the Act effectively criminalized industrial hemp by association.

Presently, the resurgence of the industrial hemp plant is successful through its rebranding as an sustainable dual-crop - the hemp stalk, refined into exemplary construction and textile materials, and the hemp seed, nutritionally superior to conventional cereal grains. Understandably,

56. Alberta Agriculture and Forestry, "Industrial Hemp Production in Canada," 2016.

57. Scott Sondles provides a detailed historical account of the industrial hemp plant and its significant contribution to our material culture in his book, *Hemponomics: Unleashing the Power of Sustainable Growth*.

Propaganda posters criminalize marijuana, and by association, hemp, 1937.

1937



Propaganda posters heroize hemp in retrospect of material necessity, 1942.

1942



Polarized Identity of a Nation State in 5 years.

Image Source; United States Government. 1937-1942. *Reefer Madness* and *Hemp for Victory*. Movie Poster. United States of America: Seeddharta. <http://www.seeddharta.nl/en/geschiedenis/>

the implementation of agricultural building materials is unconventional to the established construction industry, yet the advancement of building science reveals the industrial hemp plant to be an ideal construction medium for the rural producer. Given the established networks of the Warwick community, a sustainable Hemp Network is proposed as the architectural intervention needed to revitalize the Alberta prairie landscape.

To clarify, the Hemp Network is not a specific building, but is a network of building typologies that symbolize a sustainable rural process. The case studies of Warwick and the generational farms reveal that the agricultural process occurs between industrial and residential scales of building, and that the commercial building exists where the farmer has created a value-add process. If hemp can be processed into a conventional building form that assists the contemporary family farm operation, then the architecture can display its utility across all scales of rural dwelling - industrial, commercial and residential.

To ensure that the consumer experience is complete - for that single moment when the rural landscape is interiorized by the urban consumer - will require an architectural procession that transcends the single rural site or process. I propose two design sites to initiate the hemp network within the rural community of Warwick; the first site to establish the required decortication facility necessary to an industrial hemp network, and the second site to establish a model resilient community that embraces the rural lifestyle. The orchestration of the consumers procession through the rural landscape as it develops hemp networks of Live/Work/

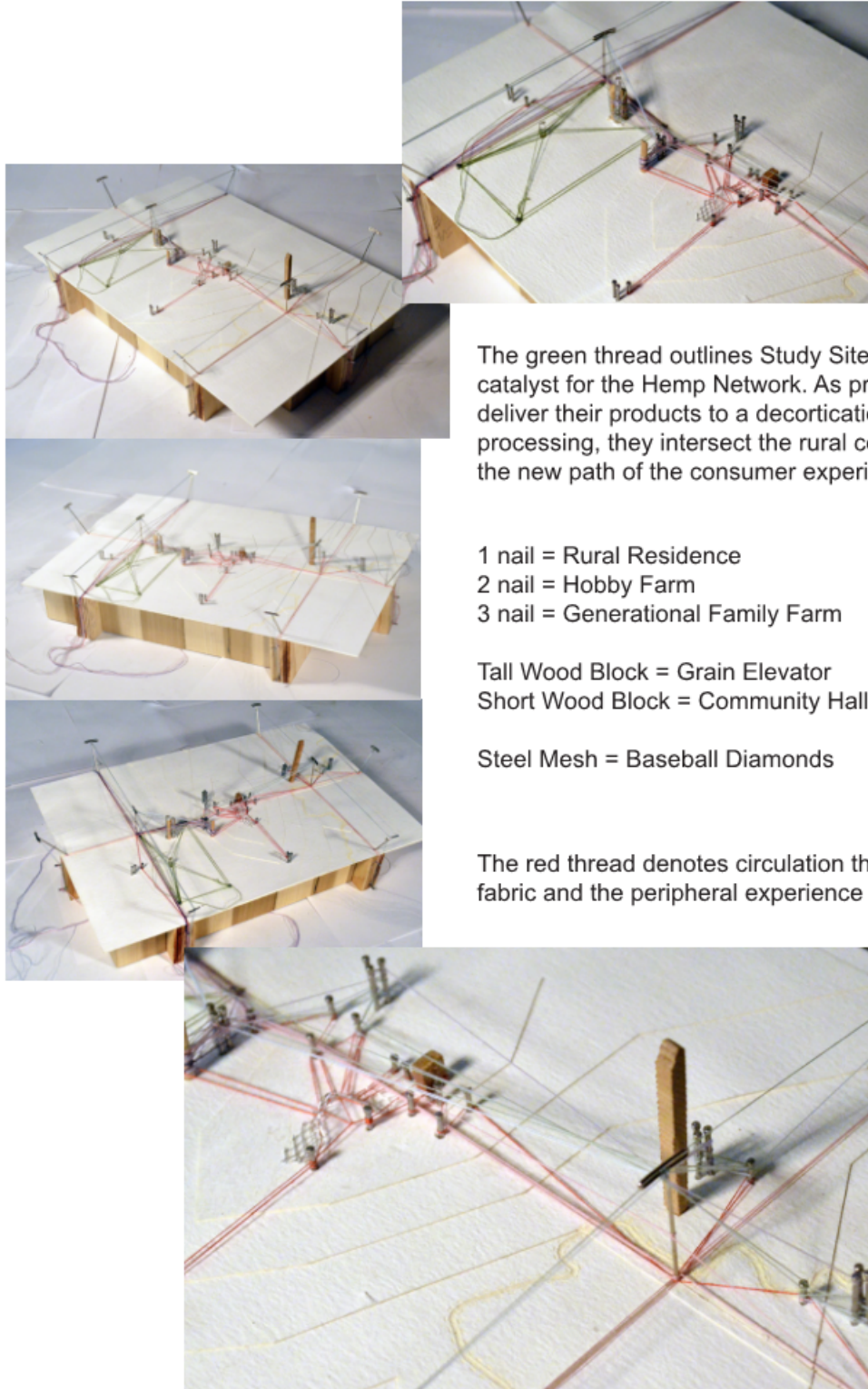

The green thread outlines Study Site 1 and the catalyst for the Hemp Network. As producers deliver their products to a decortication facility for processing, they intersect the rural community and the new path of the consumer experience.

1 nail = Rural Residence
 2 nail = Hobby Farm
 3 nail = Generational Family Farm

Tall Wood Block = Grain Elevator
 Short Wood Block = Community Hall

Steel Mesh = Baseball Diamonds

The red thread denotes circulation through the rural fabric and the peripheral experience of the built form.

Warwick Community Networks and Procession.

Threads denote the shared path of producer and consumer through the rural community and the demarcation of the rural in-between space. The grid isolates consumers from the productive field and the rural lifestyle, experienced from an egalitarian procession.

Play will allow the architecture to reveal a unique experience of the rural lifestyle become generational.

Study Site 1_The Parent Farm

Preliminary research of the industrial hemp process, from seed to product, reveals the greatest benefit of the crop requires significant investment into industrial processing facilities. These facilities are referred to as Decortication Plants, and utilize industrial machinery to separate the fibrous hemp stalk into fibres and shiv for secondary processing. In essence, this industrial process could be implemented at the scale of a generational family farm, a 4 person operating crew, and that rural producers could seamlessly integrate the hemp process into their communities through established infrastructure and shared resources.

Such is the case of my primary study site, an 80 acre grainfield and abandoned farmyard nestled between HWY 857 and the Parent farm. Presently, the Parent Farm leases this property and uses the productive field to cultivate cereal grains for livestock feed. Bounded by Warwick RD to the north and separated by fenceline from its grain field neighbor to the south, this site was selected to host the Decortication Facility and a Generational Farm for its advantageous position as the gatepost to the Warwick community.

Following the generational farm process, a new Farmhouse is built as residence for the rural producers who will operate the Decortication Facility. The Facility will become a material depot for local producers to source sustainable building products. As such, the decortication facility will relate to the industrial grid at the scale of the rural

Template models allow for the rapid development of strategic design models of procession through the rural landscape.

1 Block represents
1/4 Section.
2x2 Blocks represent
1 Section.
4x2 Blocks represent
2 miles by 1 mile.



Template Model - Double Section.

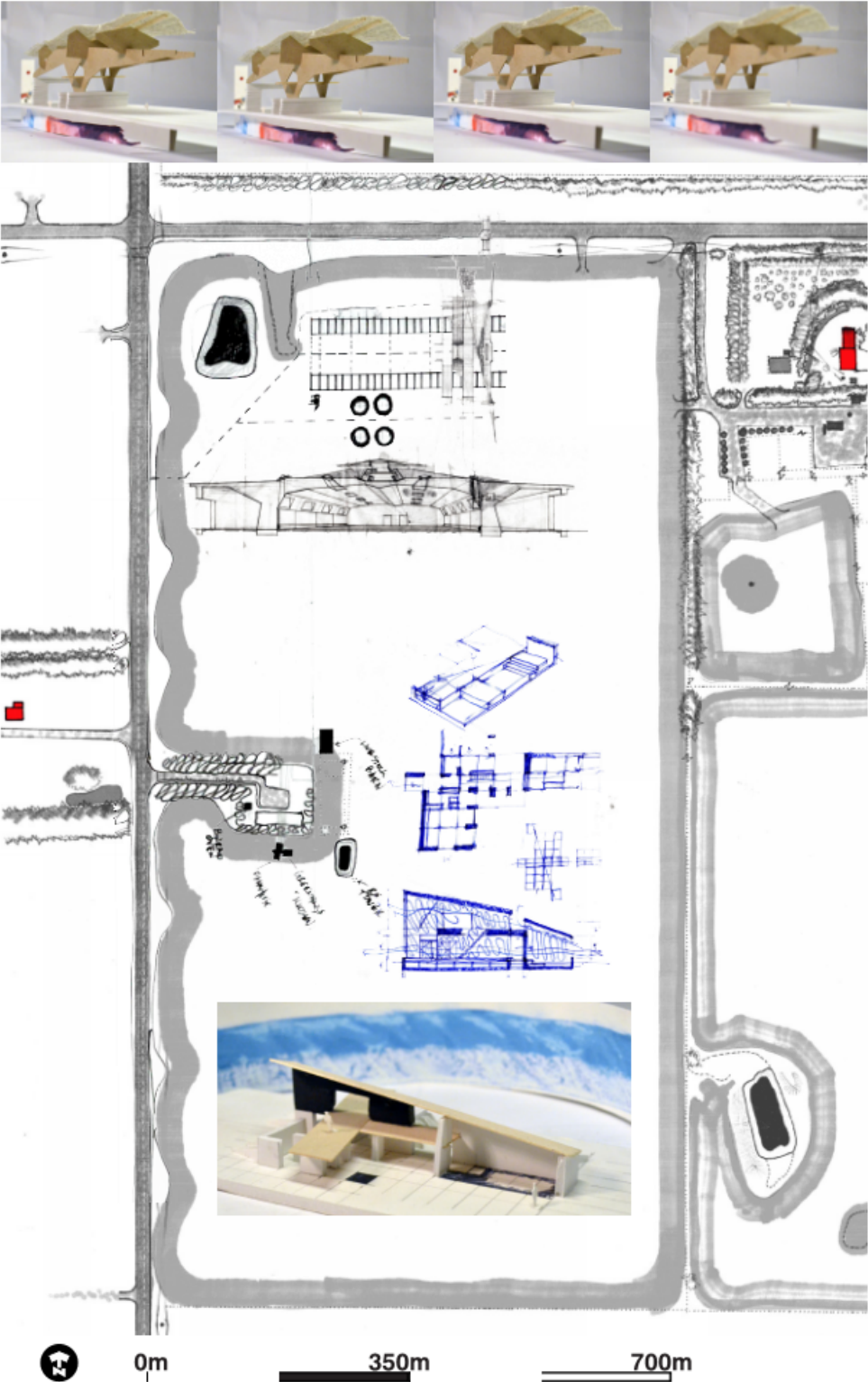

Study Site 1.
This site features a generational family farm operation that develops a value-add Hemp Decortication process to contribute to community resiliency. As a generic condition of the flat prairie landscape and gatepost to the Warwick Hemp network, Study Site 1 is an accessible demonstration of the rural producers Live/Work cycle.

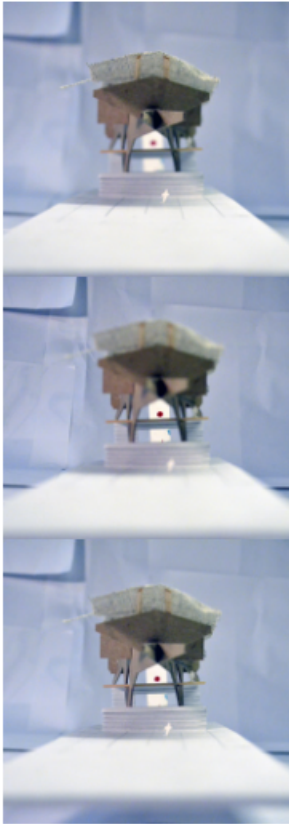

Barn Module.
Sketch Model.



Generational
Farmhouse.
Sketch Model.

landscape and will be sited at the intersection of road and productive field.

The farmhouse requires a more intimate scale and is sited according to the observed site process. The farmyard sits on the west boundary of the site, 50m east of HWY 857, and consists of a summer garden now maintained and used by my maternal grandparents, a wood-fired bannock oven formerly used for Ukrainian cultural celebrations and an assortment of agricultural storage buildings. The garden and bannock oven represent resilient typological features that are preserved through the rural lifestyle and will orient the new farmyard.

As the Decortication Facility represents the industrial nature of a hemp network and the agricultural process, it defines the Work cycle of the sustainable rural landscape. The Farmhouse represents the residential and personal nature of the agricultural process, and defines the Live cycle of a resilient rural lifestyle. Together, these typologies signify the ability of the generational family farm to regain control of the agricultural process and contribute to a sustainable material culture.

Study Site 2_The Offspring Farm

Ultimately, the design of a consumer experience which allows an individual to create their own association between a process, a medium, and a product is to teach a consumer how to produce a new experience from known elements. In an era where energy and food conservation are critical to preserving our social and cultural values, it becomes pertinent that a new agricultural process does

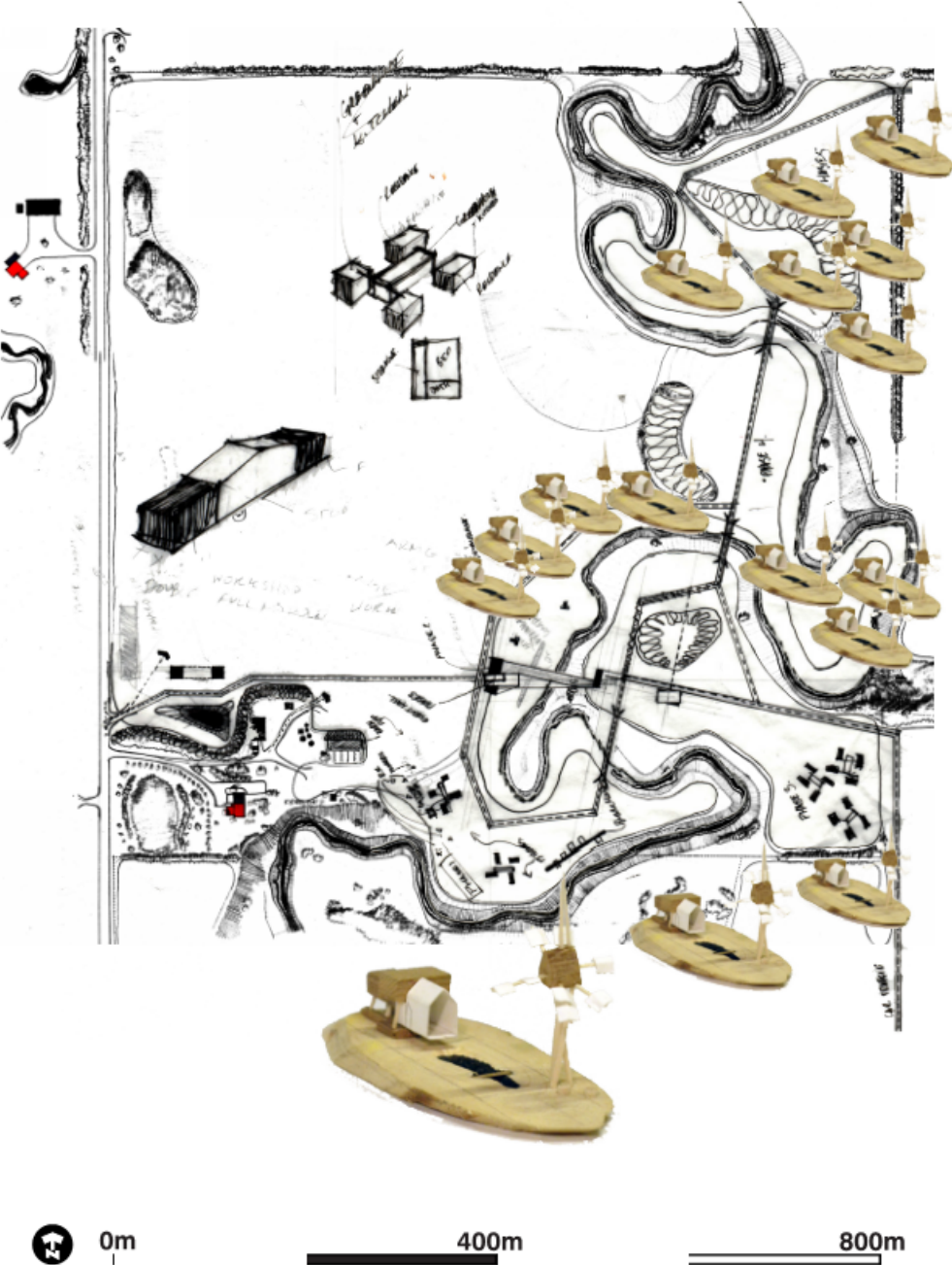

Study Site 2.
Apart of the Offspring Farm, sustainable rural community grows in-between the productive field, where natural process exists. The community hall serves the dual purpose of community celebration space and farmgate store, and marks the culmination of the Live/Work/Play cycles.

not commit old crimes but validates the necessary process. One such example is the development of Permaculture principles in response to the environmental devastation of industrial agriculture upon the Australian grasslands.⁵⁸ Foremost, the hemp network must demonstrate the value of the sustainable agricultural practice to creating resilient and desirable community models of the rural lifestyle.

The Offspring Farm represents the culmination of the generational farm process and the full integration of the Live/Work/Play cycles. As consumers benefit from the rural landscape through the product, the sustainable community model must exhibit the rural lifestyle as a product in itself - worthy of preservation. The Offspring farm will develop a series of generational Farmhouses and shared farm buildings necessary to a self-sufficient rural lifestyle. The pinnacle of the community will be a community hall that hosts the social and cultural events of the rural community. When not hosting celebrations, the community hall will function as farmgate store to provide local producers an accessible venue to engage urban consumers.

1 Block represents
1/16 Section.
4x4 Blocks represent
1/4 Section.
4x4 Blocks represent
1/2 mile by 1/2 mile



Template Model - 1/4 Section.

As the landscape of the Parent Farm is flat and perfectly suited for industrial agriculture, the Offspring landscape presents an opposite condition wherein natural systems have bisected and squiggled the industrial grid. The interstitial space of the productive field and the natural system become opportunity for rural life to flourish.

The development of the community model and

58. Bane and Holmgren discuss permanent agriculture in their book, *The Permaculture Handbook*, demonstrating a variety of sustainable agricultural practices that have been used for centuries by farmers.



Resilient Community Networks Model.
The dramatic terrain of Study Site 2 presents opportunity for the community to be revealed incrementally as the consumer experiences the landscape by foot.



The Community Hall blends the realm of industrial and residential to entice a reciprocal commercial venue that accomodates the social and cultural virtues of the sustainable rural community. Views to the natural landscape catalyze the consumer experience.

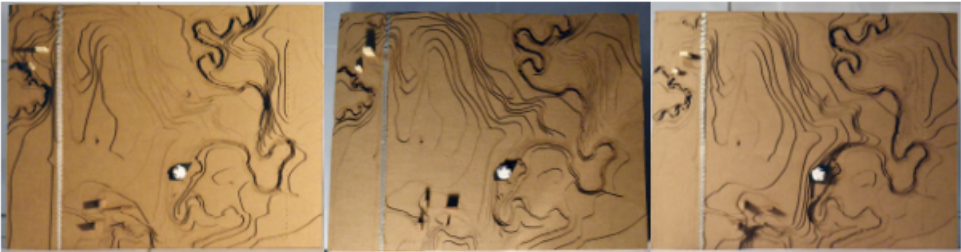

Solar Exposure of the Site.
Modelling natural cycles of the site and the intersection of community genesis.

hemp network will not be instantaneous, but will require an incremental design-build process that allows the rural community to set the pace of growth. The objective of the architecture is then to provide the basic elements for a hemp network that the rural producer would build themselves. As rural producers engage the building process, they interiorize a skill, a medium, and a product.

This concludes the architects observation of the existing rural landscape as it stands in metamorphosis. If the architecture is to successfully embody a re-imagined and sustainable agricultural process, strengthened through direct participation of urban consumers, then the application of sustainable architecture, industrial design, and planning strategies will benefit the design process.

If the lasting validity of man's past environmental experience is acknowledged, the paralyzing conflicts between past, present, and future, between old notions of space, form, and construction, and new ones, between hand production and industrial production will be mitigated.

-Aldo Van Eyck⁵⁹



The Community Hall.
Sketch Model.

59. Van Eyck, et. al., *Writings*, 474.



Aldo Van Eyck and the resultant network of city playgrounds.

Image Source; Van Eyck, Aldo. *Amsterdam City Playgrounds*. Reproduced in Lefavre, Liane, Roode, Ingeborg De, Fuchs, Rudi, and Amsterdam. 2002. Aldo Van Eyck: The Playgrounds and the City. NAI Publishers.v

Section 2: Architecture and Aldo Van Eyck

Functionalism has killed creativity. It leads to a cold technocracy, in which the human aspect is forgotten. A building is more than a sum of its functions; architecture has to facilitate human activity and promote social interaction.

-Aldo Van Eyck⁶⁰

Understanding the reality of an industrial agricultural landscape is critical to the development of a resilient architecture. Due to the complexity of rural systems and the necessity of the architect to simultaneously design in the realms of the industrial engineer and community planner, the architect looks to Aldo Van Eyck and his transition of architect to architect/urbanist with the succession of CIAM to Team 10. More so, the work of Van Eyck on the City Playground in post-war Amsterdam reveals a deeper understanding of how architecture plays a crucial role in the development of the generational city.

From analysis of Aldo Van Eyck's City Playground in Amsterdam, it is obvious that the design objectives set forth by the architect were highly successful in generating multiplicity. What is most evident from observing the work of Van Eyck is his constant pursuit of 'homecoming.'

Space has no room and time not a monument for man. He is excluded.

In order to 'include' him - help his homecoming - he must be gathered into their meaning. (Man is the subject as well as the object of architecture)

Whatever space and time mean, place and occasion mean more.

For space in the image of man is place and time in the image of man is occasion.

Today space and what it should coincide with in order to

60. Ibid., 530.

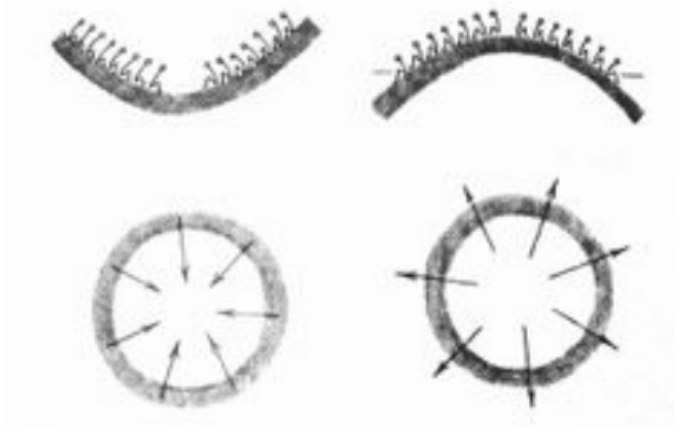

Aldo Van Eyck's diagrams of centrality; two forms of being together or alone.

Image Source; Van Eyck, Aldo. 1949. *A Tree is a Leaf, A Leaf is a Tree*. Reproduced in Eyck, Aldo Van, Ligtelijn, Vincent, and Strauven, Francis, eds. 2008. *Writings*. Amsterdam: SUN.

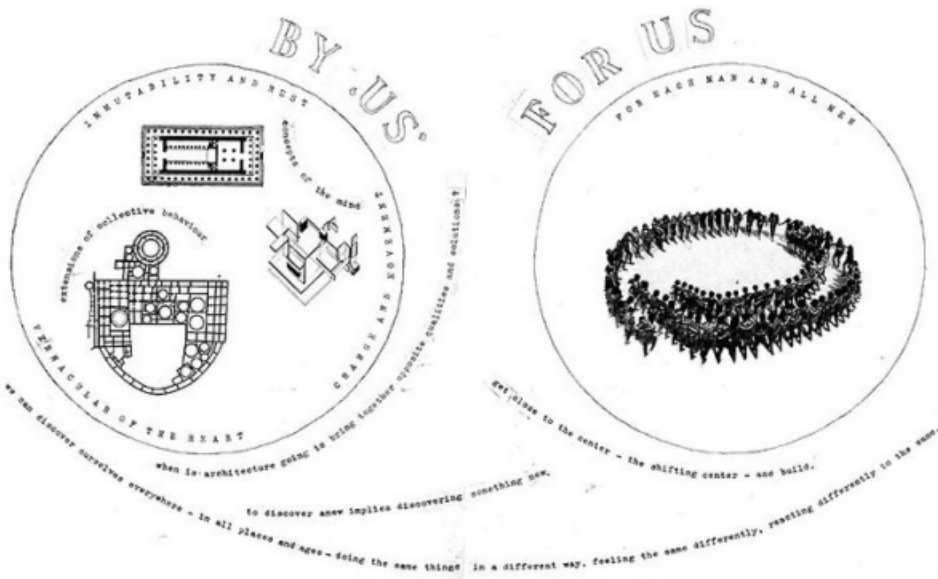

Aldo Van Eyck's collage of the Aesthetics of Number

Image Source; Van Eyck, Aldo. 1959. *Otterlo Circles*. Reproduced in Eyck, Aldo Van, Ligtelijn, Vincent, and Strauven, Francis, eds. 2008. *Writings*. Amsterdam: SUN.

become 'space' -- man at home with himself -- are lost. Both search for the same place but cannot find it.

Provide that place.

Is man able to penetrate the material he organizes into hard shape between one man and another; between what is here and what is there; between this and the following moment? Is he able to find the right place for the right occasion?

No -- So start with this: make

A welcome of each door and a countenance of each window.

Make each a place: a bunch of places of each house and each city, for a house is a tiny city, a city a huge house.

Get closer to the shifting centre of human reality and build its counterform -- for each man and all men, since they no longer do it themselves.

Whoever attempts to solve the riddle of space in the abstract will construct the outline of emptiness and call it space.

Whoever attempts to meet man in the abstract will speak with his echo and call this dialogue.

Man still breathes both in and out. When is architecture going to do the same?

-Aldo Van Eyck⁶¹

A taunt for the aspiring architect, Van Eyck is clear in his understanding of homecoming and jests for other architects to establish theirs. When we consider what Van Eyck means by an architecture that can 'breathe' like man, it seems apparent that he refers to the landscape and natural cycles which inevitably rule us, so why resist? If we can choose to live in a place for the opportunity it may provide, why must we remove that opportunity for others by defining and limiting the roles of time and space?

Space and time must be 'opened' -- interiorized -- so that they can be entered: persuaded to gather man into their meaning -- include him.

By virtue of what memory and anticipation signify, place

61. Ibid., 47.

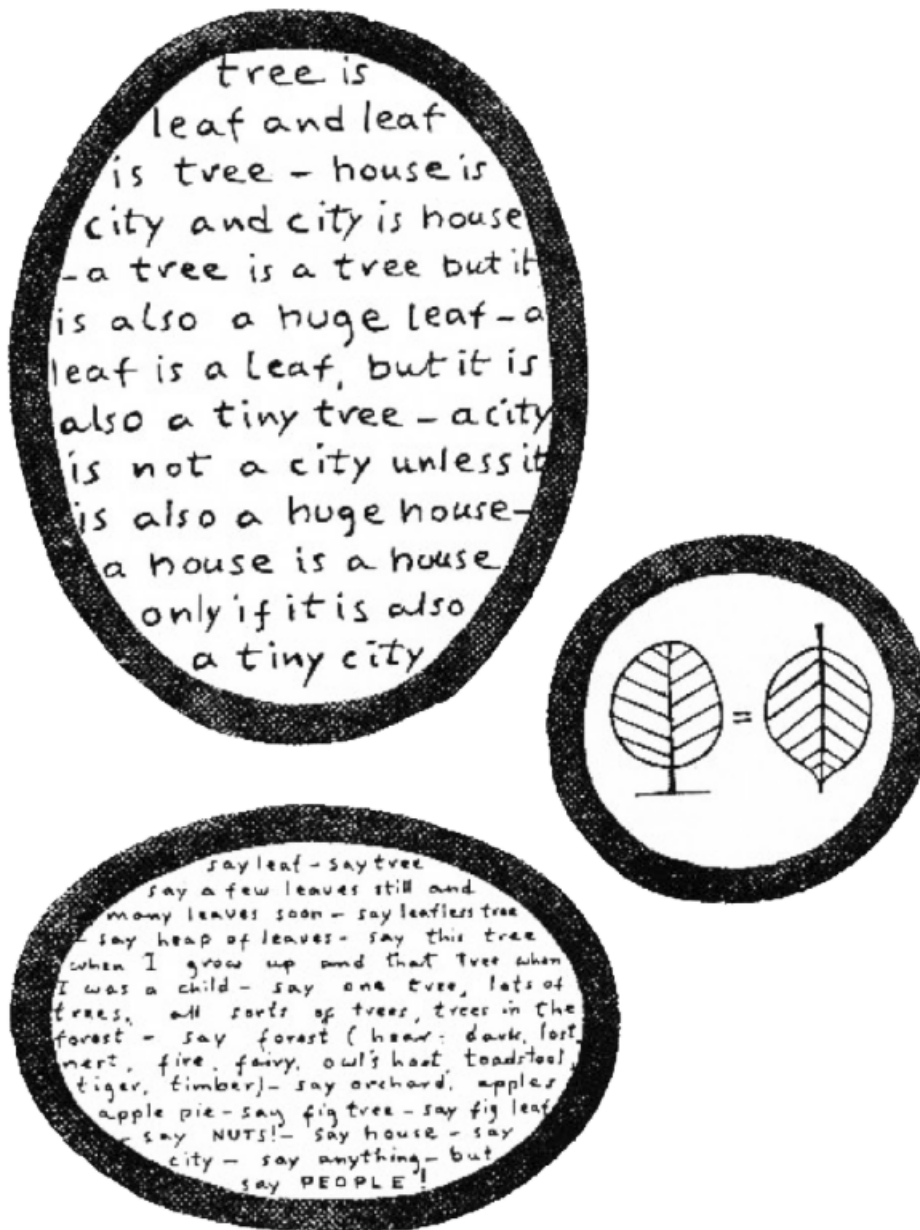

Aldo Van Eyck's, A Tree is a Leaf.

Diagram of the Twin Phenomena concept and the reciprocal nature of object and idea.

Image Source; Van Eyck, Aldo. 1962. *The 'Tree-Leaf' Diagram*. Reproduced in Eyck, Aldo Van, Ligtelijn, Vincent, and Strauven, Francis, eds. 2008. *Writings*. Amsterdam: SUN.

acquires temporal meaning and occasion spatial meaning. Thus space and time, identified reciprocally (in the image of man) emerge, humanized, as place and occasion. (Whatever space and time mean, space and occasion means more.

Places remembered and places anticipated dovetail in the temporal span of the present. They constitute the real perspective of space.

What matters is not a space but the interior of space -- and the inner horizon of that interior.

The large house -- little city statement is ambiguous and consciously so. In fact, its ambiguity is of a kind I should like to see transposed to architecture. It points, moreover, towards a particular kind of clarity neither house nor city can do without. A kind which never quite relinquishes its full meaning.

Call it labyrinthian clarity.

Such clarity (ally of significant ambiguity) softens the edges of time and space and transcends visibility (allows spaces to enter each other and occasions to encounter each other in the minds interior).

It is kaleidoscopic.

The in-between realm is never without it.

Right-size goes hand in hand with it (and so, of course, does the inner horizon of space).

It harbours bountiful qualities: scope for that which is small yet large -- large yet small; near yet far -- far yet near; open yet closed -- closed yet open; different yet the same -- the same yet different; scope for the right delay, the right release, the right certainty, the right suspense, the right security, the right surprise; and withal, scope for multimeaning.

There is a kind of spatial appreciation which makes us envy birds in flight; there is also a kind which makes us recall the sheltered enclosure of our origin. Architecture will fail if it neglects either the one or the other. Labyrinthian clarity, at any rate, sings of both.

Aldo Van Eyck⁶²

What Van Eyck uncovers in his explorations of the reciprocal is a world of ordered chaos; that people are chaos acting within an ordered landscape. Labyrinthian

62. Ibid., 472.



Motion -- Rest



Twin Phenomena - Man dreams of flight, so he draw`s a bird.

clarity is used to describe the complexity of the individual and collective social associations which drive the anthropogenic development of artefact. In the continuous cycle of consumerism, an object turns from used to disused, to discard, to found object, to museum display.⁶³ It is unbelievable to conceive of building a museum that would cover the entirety of the rural landscape, so what will happen when the rural landscape is irreversible transformed to an industrial landscape? What will compose the display of the generational family farm? If the intent of consumers is to reconnect with their food productive landscapes so that they remain productive, then consumers must reciprocate the efforts of the producers to maintain those landscapes.

Reciprocity of the Antonym

In response to the polarization of the urban and rural landscape, the architecture must mediate the consumer experience of urban lifestyle to agricultural process. Literally, the procession from urban experience to rural fabric is an opportunity for the consumer to reflect on present event, to anticipate arrival, or to imagine experience. As the urban realm compartmentalizes itself, the proximity of local producers becomes irrelevant to a global world and design should reconcile this distance by seeking to fill the in-between space with the visage of a sustainable rural community. The architect must not isolate the architecture as one-off products and over-invest in technology as public architecture; but must consider how the multiple product already exists so as to enhance the rural notion of homecoming. In essence, the architecture must reciprocate urban determinism with rural determinism.

63. Tyler Dixon, *Exodus*, 29.

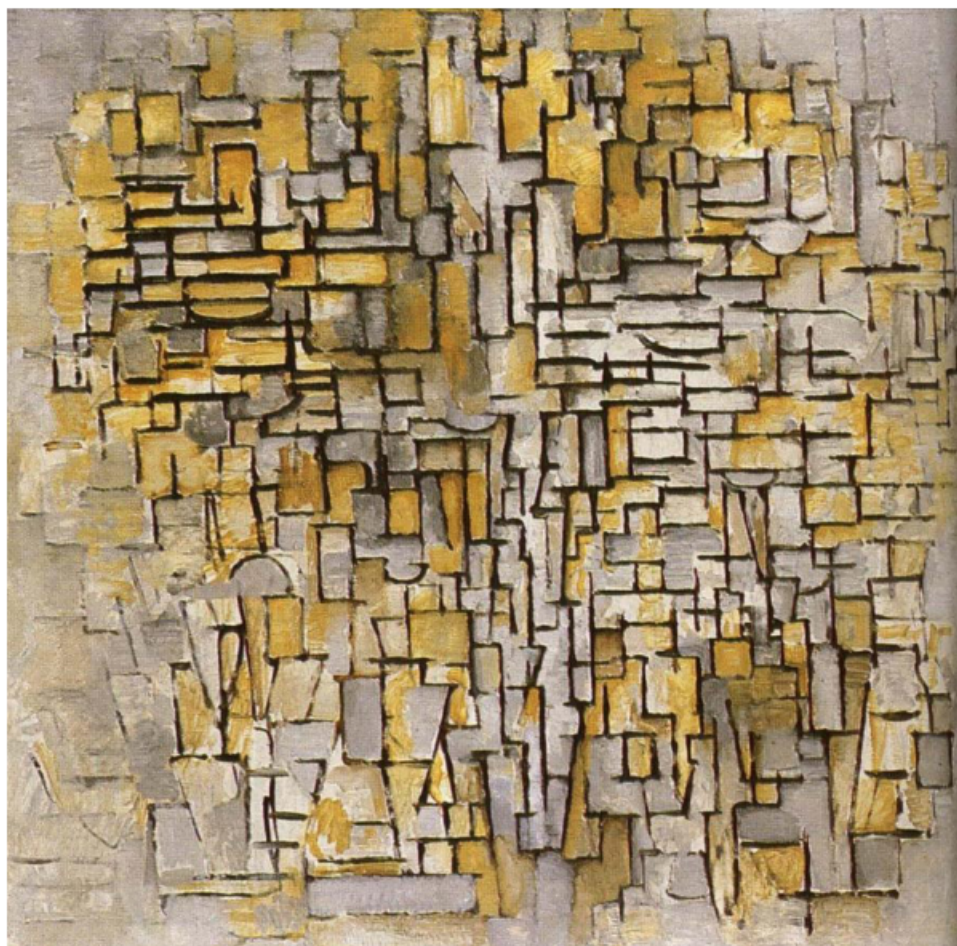

Piet Mondrian, *Composition no. VII*, 1913, oil on canvas.
De Stijl abstraction and the configurative development of the Polycentric Net - objects acting and reacting to each other to create a whole.

Image Source; Piet Mondrian. 1913. *Composition no. VII*. Oil on Canvas. Piet Mondrian: Biography, Paintings, and Quotes. <http://www.piet-mondrian.org/composition-number-7.jsp>

As such, the notion of Twin Phenomena fascinated Van Eyck and inspired much of his design theory. Beyond the reality of our built form, we create distinct and ever-changing social associations between the human and non-human; but what unifies communities is a shared identity -- the identity of the individual only exists if the identity of the community exists, and vice versa. The urban and rural are twin phenomena, a part of the whole and the whole of parts, wherein the parts are scalar and intertwined yet constantly polarized.

I am concerned with twin phenomena; with unity and diversity, part and whole, small and large, many and few, simplicity and complexity, change and constancy, order and chaos, individual and collective; with why they are ignobly halved and the halves hollowed out; ...

... As abstract antonyms the halves are rendered meaningless. As soon however as they are permitted to materialize into house or city their emptiness materializes into cruelty, for in such places everything is always too large and too small, too few and too many, too far and too near, too much and too little the same, too much and too little different. There is no question of right-size (the right effect of size) and hence no question of human scale. ...

... If a thing is too much and too little the same, it will also be too much and too little different. Right-size will flower as soon as the mild gears of reciprocity start working -- in the climate of relativity; in the landscape of all twin phenomena.

-Aldo Van Eyck⁶⁴

What Twin Phenomena establishes for the architectural design process is a methodology of developing appropriately scaled architectural interventions amongst a vastness of space; to design for multiplicity. To be specific, the antonym reveals opposites that are similar, yet language as a modernist design medium often polarizes the design objectives, and, what Van Eyck sought to resolve by

64. Van Eyck, et. al., *Writings*, 327.

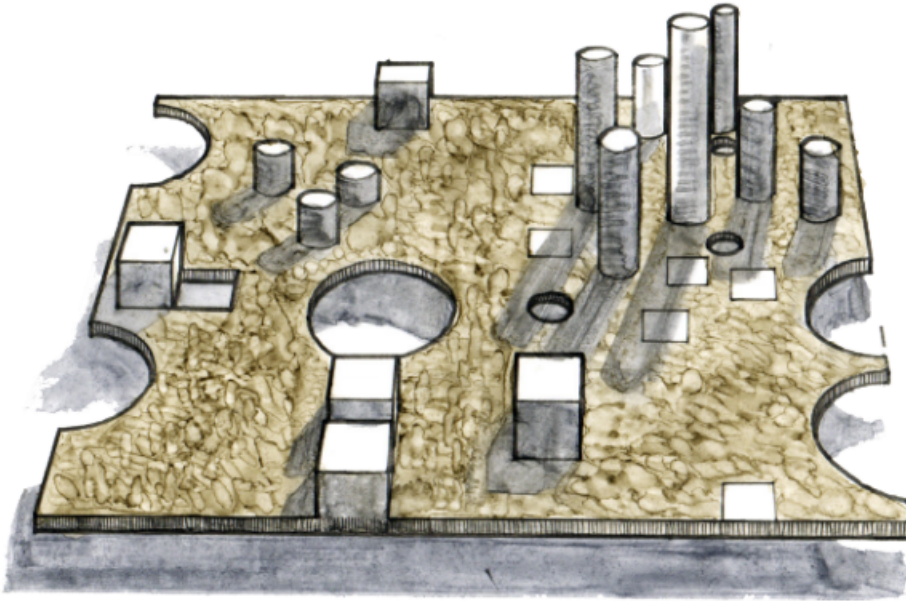

Aldo Van Eyck's primary inspiration for the planning of City Playgrounds. Drawing of *Relief Rectangular*, 1936, by Sophie Tauber-Arp.

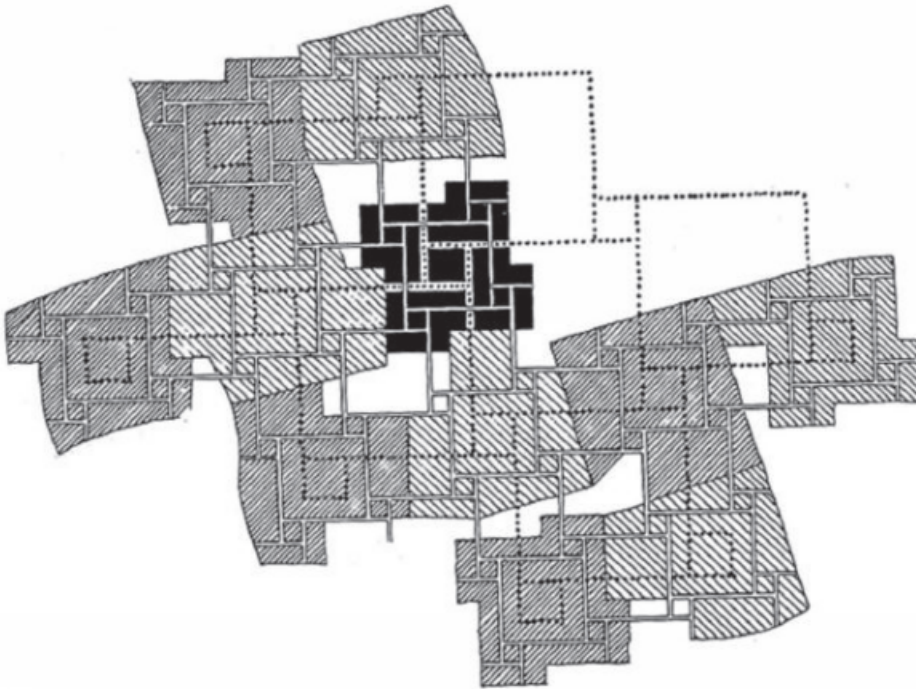

Aldo Van Eyck, Configurative Design Model.
Diagram demonstrating nodal growth and multiplication.

Image Source; Blom, Piet. 1972. *Arc of Noah*. Study Project. Reproduced in Eyck, Aldo Van, Ligtelijn, Vincent, and Strauven, Francis, eds. 2008. *Writings*. Amsterdam: SUN.

addressing the connotations of a black and white design world. In that a city is big and a house is small, clear hierarchies of association limit the potential for re association. As Twin Phenomena is a result of western design principles that separate process from place via the hierarchy of socio-technical requirements, Van Eyck sought to reciprocate this notion of technocracy with one of humanism.

Aldo Van Eyck's theory of the Reciprocity of the Antonym reacts to the modernist approach -- one of isolating identity so as to present a very clear and simplified concept for rapid consumer uptake. However, when considering the scalar quality of human activity and association, the urban often fails to accommodate the local process in favour of technological efficiency. This to say that the widespread adoption of the modernist building technologies, and the succinct commercialization of modernist architecture, favoured technocratic hierarchy over vernacular form -- something quite evident of Edmonton, Calgary, and by extension, Alberta.⁶⁵

A Configurative Approach to the In-between Space

As soon as the equilibrating impact of the in-between realm -- extended so that it coincides with the bunch of places both house and city should be -- manifests itself in a comprehensibly articulated configuration, the chances that the terrifying polarities that hitherto harass man's right composure may still be reconciled, will be certainly greater.

It is still a question of twin phenomena; a question of making the in-between places where they can be encountered, readily mitigating psychic strain. What is direly needed is a dimensional change both in our way of thinking and working which will allow the quantitative nature of each separate polarity to be encompassed and mitigated by the qualitative nature of all twin phenomena combined: the medicine of reciprocity.

65. Trevor Boddy, *Modern Architecture in Alberta*, 1987.

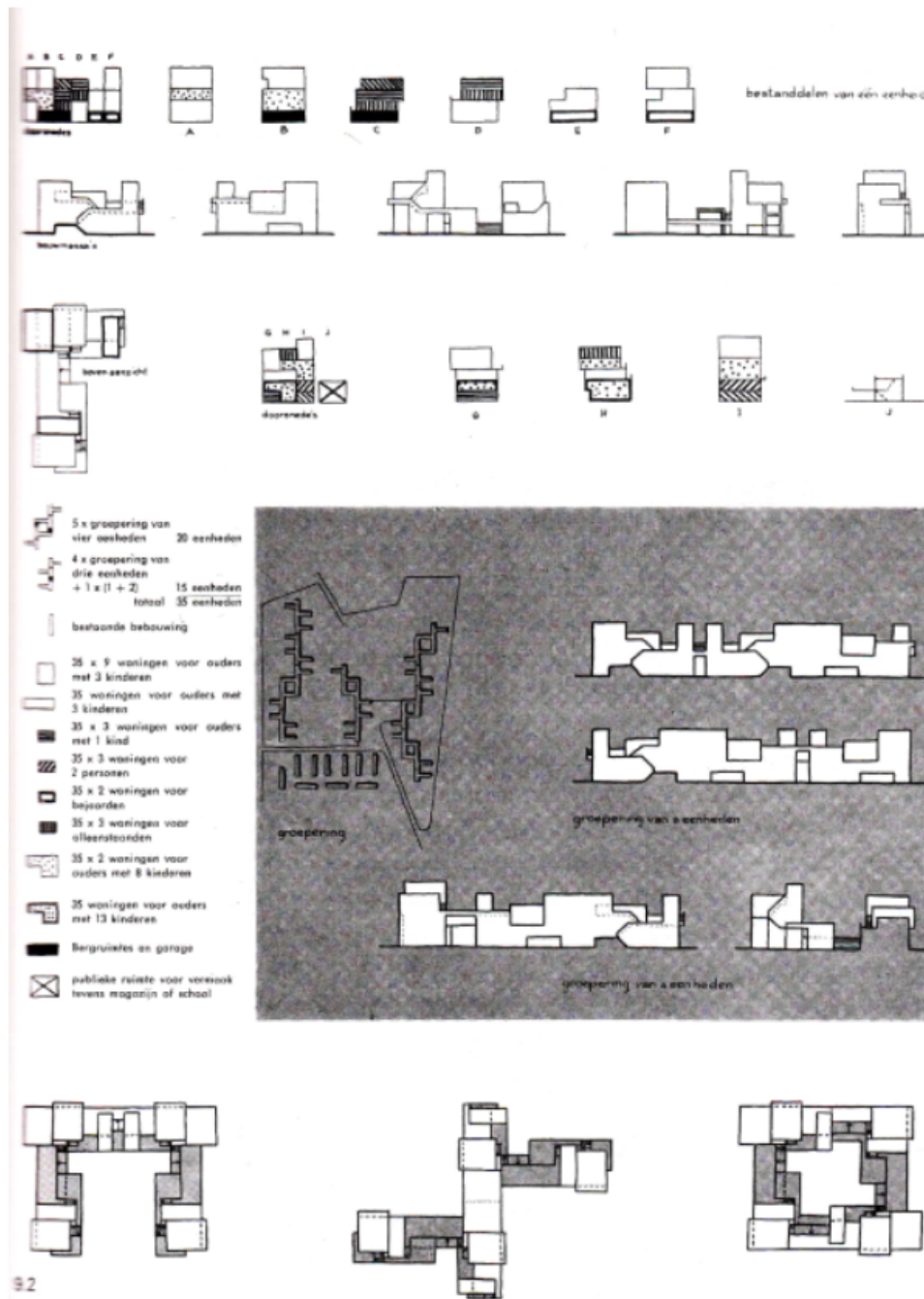

Piet Blom, *The Cities will be Inhabited like Villages*. Study Project, 1958. Assembling the elements of the configurative approach.

Image Source; Blom, Piet. 1958. *The Cities will be Inhabited like Villages*. Study Project. Reproduced in Eyck, Aldo Van, Ligtelijn, Vincent, and Strauven, Francis, eds. 2008. *Writings*. Amsterdam: SUN.



Noahs Ark, Configurative Design Theory.
Piet Blom.

-Aldo Van Eyck⁶⁶

How the architecture begins to reciprocate the urban and rural is through the agricultural medium; in that the urban consumes and the rural produces, in that the cycles of seed, plant, harvest resound of birth, life, death. As associations and centres shift with the chaos of space and time, the in-between is constantly re-interpreted and demands an architecture that makes no other assumption. Given this complexity, Aldo Van Eyck sought to develop a configurative architecture which could unburden itself from the obsolescence of polar antonyms; one that rejected architecture and urbanism as distinct and separate disciplines. Van Eyck describes the configurative approach as;

Each individual dwelling possess the potential to develop, by mean of configurative multiplication, into a group (sub-cluster) in which the identity of each dwelling is not only maintained but extended in a qualitative dimension that is specifically relevant to the particular multiplicative stage to which it belongs. Whilst the resulting group is, in turn, fortified in the next multiplicative stage by a new identity which will again enrich what precedes it.

-Aldo Van Eyck⁶⁷

The case studies of the Grandparent, Parent, and Offspring farm reveals that configurative design is not a new concept but a social mechanism of generational family farms. Beyond the built form, social associations ultimately drive the continued use and operation of a building after it has lost its function, an inevitable consequence of time and process evolution. As Van Eyck said, whatever space and time mean, place and occasion mean more, and thus the

66. Van Eyck, et. al., *Writings*, 329.

67. *Ibid.*, 329.

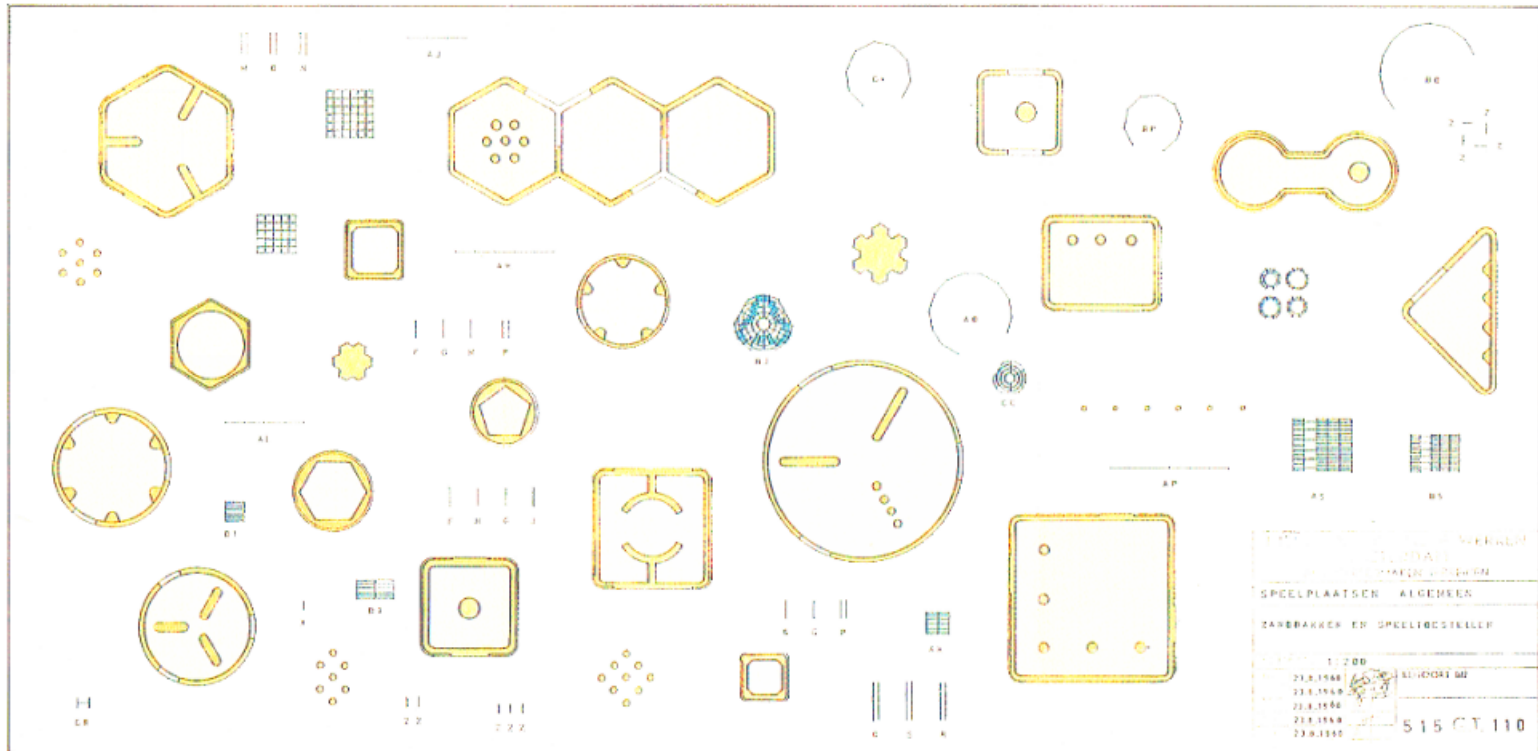

City Playground Elements.

Aldo Van Eyck's drawings of the basic playground equipment that would be replicated in various configurations at different playground sites. The elemental form allows for endless association and reassociation.

Image Source; Drawing by the Site Preparation Division of the Department of Public Works. 1960. *Playground Elements* designed by Aldo Van Eyck. Stedelijk Museum, Amsterdam. Reproduced in Lefaiivre, Liane, Roode, Ingeborg De, Fuchs, Rudi, and Amsterdam. 2002. Aldo Van Eyck: The Playgrounds and the City. NAi Publishers.

rural landscape must become place and occasion. Given the vastness of the rural landscape, place and occasion must be extended to every surface - so as to not be considered simply as space and time. Thusly, the in-between space becomes void by which the architecture must entrench itself, and exhibit multiplicity, so as to demonstrate the validity of sustainable rural landscapes - the quintessential procession between homecomings.

Aesthetics of Number

We have forgotten most of what there is to know about the aesthetics of the single thing, whilst we know little yet about the aesthetics of multiple things. The capacity to impart order within a single thing -- to make it rest within itself -- is unfortunately no longer ours and that is a terrible thing; we cannot do without classical harmony. The capacity, however, to impart order to a multiplicity of things is as unfortunately not yet ours either, and that is a terrible thing too, for we cannot do without harmony in motion.

... We must continue the search for the basic principles of a new aesthetic and discover the human meaning of number. We must impart rhythm to repetitive similar and dissimilar form, thereby disclosing the conditions that may lead to the equilibration of the plural, and thus overcome the menace of monotony.

- Aldo Van Eyck⁶⁸

In context, the rural landscape is not densely populated when compared to urban communities, yet the proportional area of landscape that is maintained and utilized by the rural producer when compared to the urban resident, it is evident that rural producers can have a profound effect on the regional ecology of any place. This is to say that as the urban consumer centres their lifestyle outside of rurality, they disassociate their lifestyle from rural landscape and its potential to benefit their lives directly.

68. Ibid., 333.

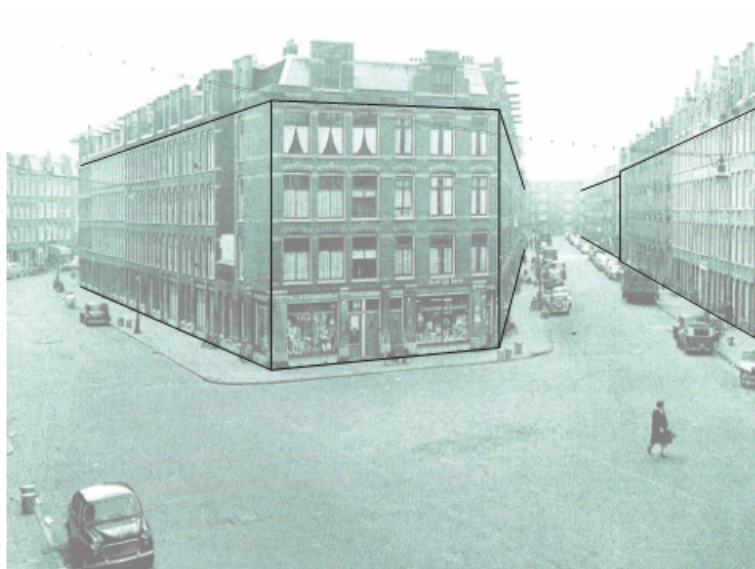

Aldo Van Eyck, City Playgrounds.
Van Boetzelaerstraat, Amsterdam-Oudwest, 1961-1964

Base Image Source; Van Boetzelaerstraat. 1961-1964. *Staatliedenbuurt*. Amsterdam-Oudwest, Stedelijk Museum, Amsterdam. Reproduced in Lefaivre, Liane, Roode, Ingeborg De, Fuchs, Rudi, and Amsterdam. 2002. Aldo Van Eyck: The Playgrounds and the City. NAI Publishers.

As well, when the urban consumer begins to demand real experience, how often do they turn to the rural landscape adjacent to relieve the psychic strains of urbanity? How often do they choose distant urban centres to visit and consumer? As rural producers steward over the vastness of our productive landscapes, how can urban centres allow their productive landscapes to cannibalize themselves through industrialization?

If the in-between space, the vastness, is to be experienced by the consumer, than architecture must grow into the voids of landscape that have been varnished by the industrial process; the places most devoid of attention. By developing an architectural form, or forms, that speak to a sustainable or resilient agricultural process, the consumer may chance upon the forms as they navigate time and space. For this architecture to form and become plural, it requires rural producers to make the new forms inherent to their process. The Aesthetics of Number seeks to make a quality architecture for everyone and must define the basic elements of homecoming. What results of the architecture must become plastic so as not to impress a single notion of homecoming upon consumers, as the key to teaching the consumer will require the consumer to desire teaching someone else of their experience.

In-between Space and Polycentric Networks

In discussing the in-between space and the notion of the generational farm as the intermittent image that the consumer experiences, we must validate how to most efficiently catalyze the hemp network within the rural landscape. It is not realistic for all the elements for a

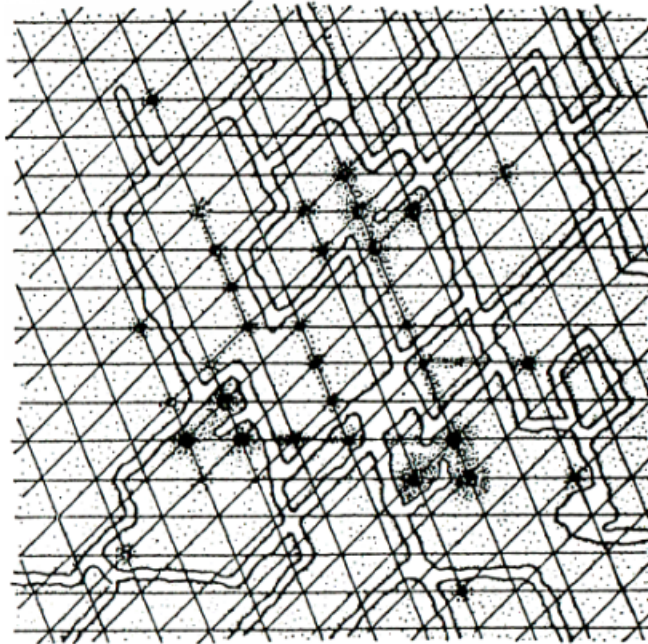

Kevin Lynch, Polycentric Networks.

Image Source; Lynch, Kevin. 1961. *'Polycentric Net' and 'Galaxy'*. Reproduced in Lefaivre, Liane, Roode, Ingeborg De, Fuchs, Rudi, and Amsterdam. 2002. Aldo Van Eyck: The Playgrounds and the City. NAI Publishers.

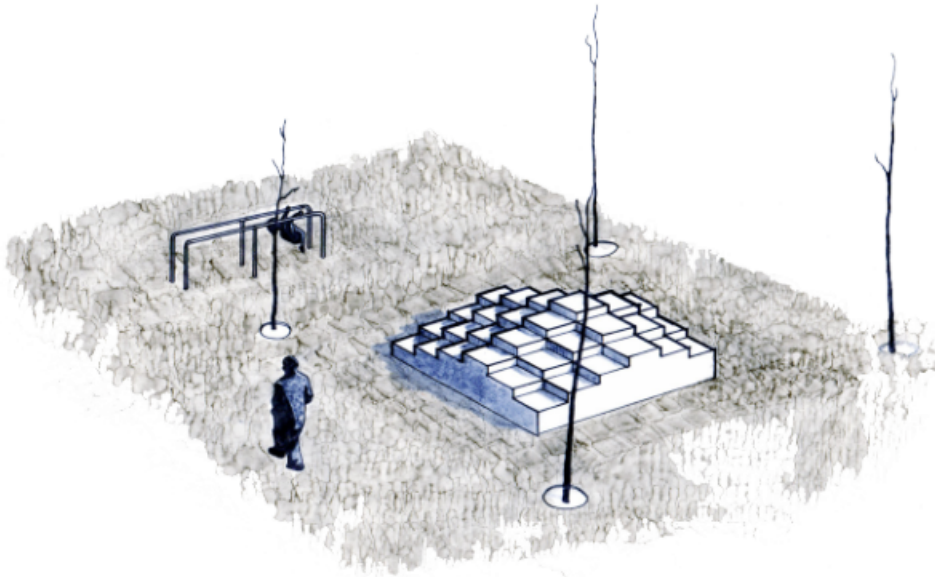

Aldo Van Eyck, City Playgrounds.

Adding sculpture to the City Playground would reinvent the play surface.

Base Image Source; Dapperbuur. 1955-1958. *Oetewalerpad with Concrete Climbing Mountain*. Amsterdam-Oost, Stedelijk Museum, Amsterdam. Reproduced in Lefaivre, Liane, Roode, Ingeborg De, Fuchs, Rudi, and Amsterdam. 2002. Aldo Van Eyck: The Playgrounds and the City. NAI Publishers.

sustainable network to appear overnight, and will require a germination period wherein a network grows as demand grows. As such, I will explore the idea of Polycentric Networks to describe how the generational family farm fills the void of the in-between and creates a web of producer, process, and landscape that can inspire consumers to adopt principles of sustainability into their own lifestyles. Utilizing the Aesthetics of Number, architecture can provide universal elements that assist the producer at distinct sites of their process, and through multiplicity, imply a greater social process of community stewardship.

The Polycentric Network, or Galaxy, is an urban theory which maps community perception of distinct social associations and their implicit networks. Coined by famed urban theorist Kevin Lynch, Polycentric Networks are the derivative association 'knots of density', wherein a random distribution of activity nodes develop the in-between space to become supportive of a common social and cultural objective.⁶⁹ When acknowledging that Aldo Van Eyck was involved in the construction of over 700 playgrounds across Amsterdam, a task of multiplicity, the city is described as germinating a galaxy of architectural forms that teach children to Play in the city. I will use the case study of the City as Playground to exemplify architectural design principles for the aesthetics of number.

City as Playground

It is important to put into the context the design profession at the time the Aldo Van Eyck began his work

69. Lefaivre, Roode, and Fuchs, eds., *Aldo Van Eyck : The Playgrounds and the City*, 47.

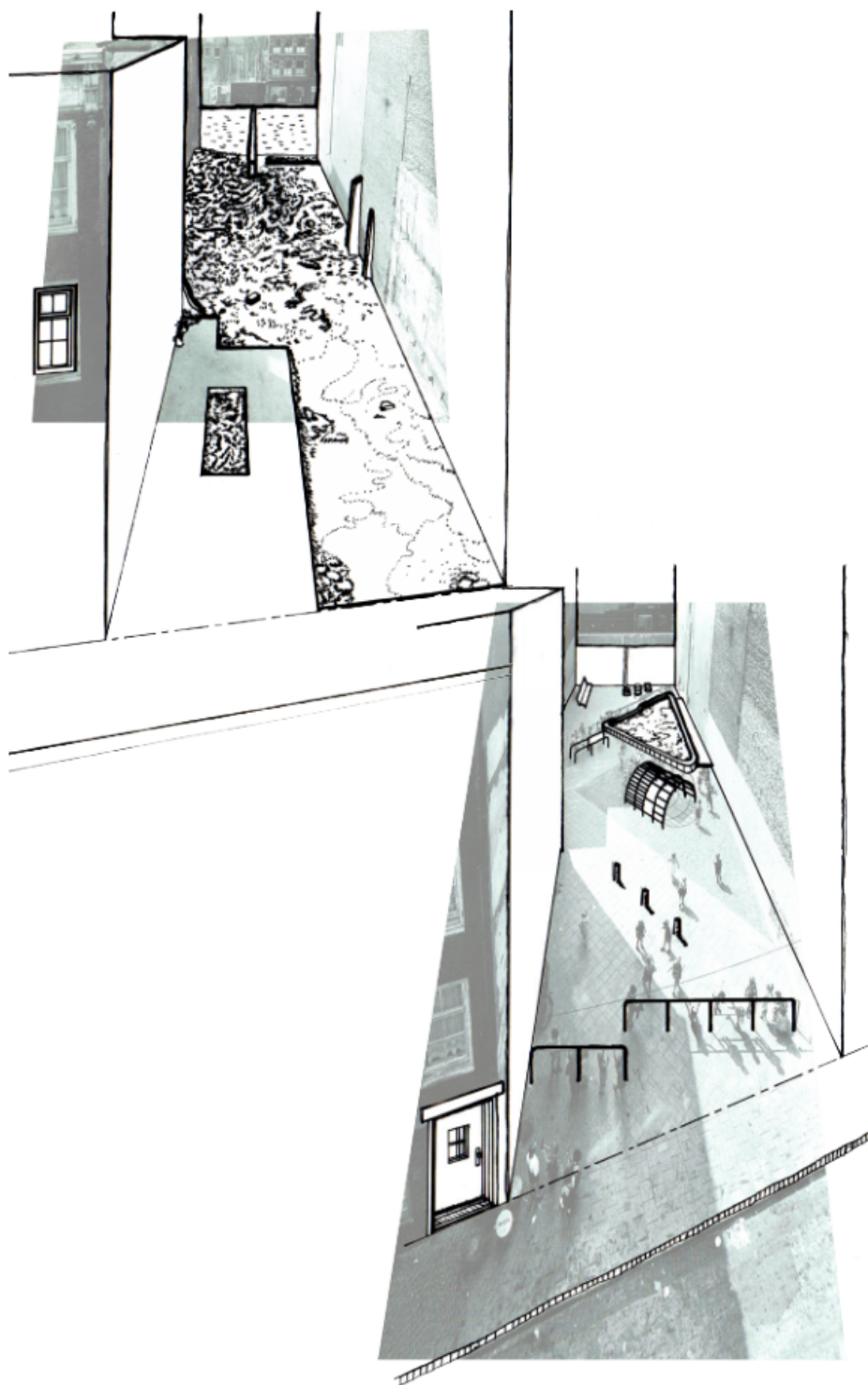

Aldo Van Eyck, City Playgrounds.
Dijkstraat, Amsterdam-Centrum, 1954.

Base Image Source; Creator unknown. 1954. *Dijkstraat*. Amsterdam-Centrum, Stedelijk Museum, Amsterdam. Reproduced in Lefavre, Liane, Roode, Ingeborg De, Fuchs, Rudi, and Amsterdam. 2002. Aldo Van Eyck: The Playgrounds and the City. NAI Publishers.

on city playground's, and the deteriorated state of post-war Amsterdam. Working for the city planning department, Van Eyck opposed the classical approach to urban design which entailed a top-down, hierarchical, and standardizing approach; the planner was obsessed with the notion of framework and the capsulized nature of the urban reality.⁷⁰ As the city was in a state of modernization, the historic character was at fault of being scrubbed away through the concretely regimented urban plan, letters from concerned residents began to pour in, asking for real playgrounds in place of empty lots and house rubble that facilitated the Amsterdam child's notion of play. As it was, Aldo was implicit in the development of three design principles that respond to form, multiplication and urban fabric.

Because Van Eyck practised as architect/urbanist, he gained a deeper understanding of how architecture and urban theory intersected within the individual's daily lifestyle. This insight led Van Eyck to consider what the deeper meaning of a playground means to a child, to a neighborhood, to a city. Because the rudimentary elements for social and physical play are often made simple in their resiliency, those elements take on the inherent geometric forms of the city, and thus represent a scalar quality of inhabitable environment. As well, the individual organizes their association of the space to create place and occasion, and must activate imagination to effectively make a public space their own. In this way, the repetitive and distinguishable element may take on any number of associations at the behest of the individual acting on it relative to the imagined need on the individual. Aldo Van Eyck used the city playground as multiple test sites,

70. Ibid., 25.

Aldo Van Eyck, City Playgrounds.
Relativity and imagination in process,



Base Image Source;

Spaarndammerbuurt, Zaanhof. 1950. *Stepping Stones*. Amsterdam-Oudwest, Stedelijk Museum, Amsterdam: Rotterdam. Reproduced in Lefaivre, Liane, Roode, Ingeborg De, Fuchs, Rudi, and Amsterdam. 2002. Aldo Van Eyck: *The Playgrounds and the City*. NAI Publishers.

Hendrikplantsoen, Frederick. 1959. *Climbing Arch*. Amsterdam-Oudwest, Stedelijk Museum, Amsterdam: Rotterdam. Reproduced in Lefaivre, Liane, Roode, Ingeborg De, Fuchs, Rudi, and Amsterdam. 2002. Aldo Van Eyck: *The Playgrounds and the City*. NAI Publishers.

acting independently but having the shared identity through common form, to explore relativity and association.

As Aldo Van Eyck opposed the hierarchical approach of the conventional planning authorities, he sought to design the counterform, and thus the bottom up design approach which valued mutual development; the City Playground was developed so that all elements are equal. Three design principles are derived from the City Playground; minimalist intervention to stimulate the imagination, modular character allows for endless combinations, and relationship to urban environment to interact with the urban fabric. Together, these principles reflect the design intent to create a subjective experience that elevated the experience of space and time to place and occasion.

Amsterdam Playgrounds

Aldo Van Eyck used the Amsterdam city playground to explore his design theories of how architecture may formalize the individuals ability to create relative associations between form, activity and landscape through the activity of Play. It is argued that the playgrounds had a profound effect on the children of Amsterdam, as their collective experience of play would influence their positive engagement of the city for life - the playgrounds became sites for children to test the social realm of play in the urban context. Furthermore, the development of a plural design form that could reorganize itself in relation to site allowed the architecture to form genus loci at distinct sites, yet the multiplicity of place and occasion creates a polycentric net of shared identity.

The principles of the City Playground will easily

Value Add Network

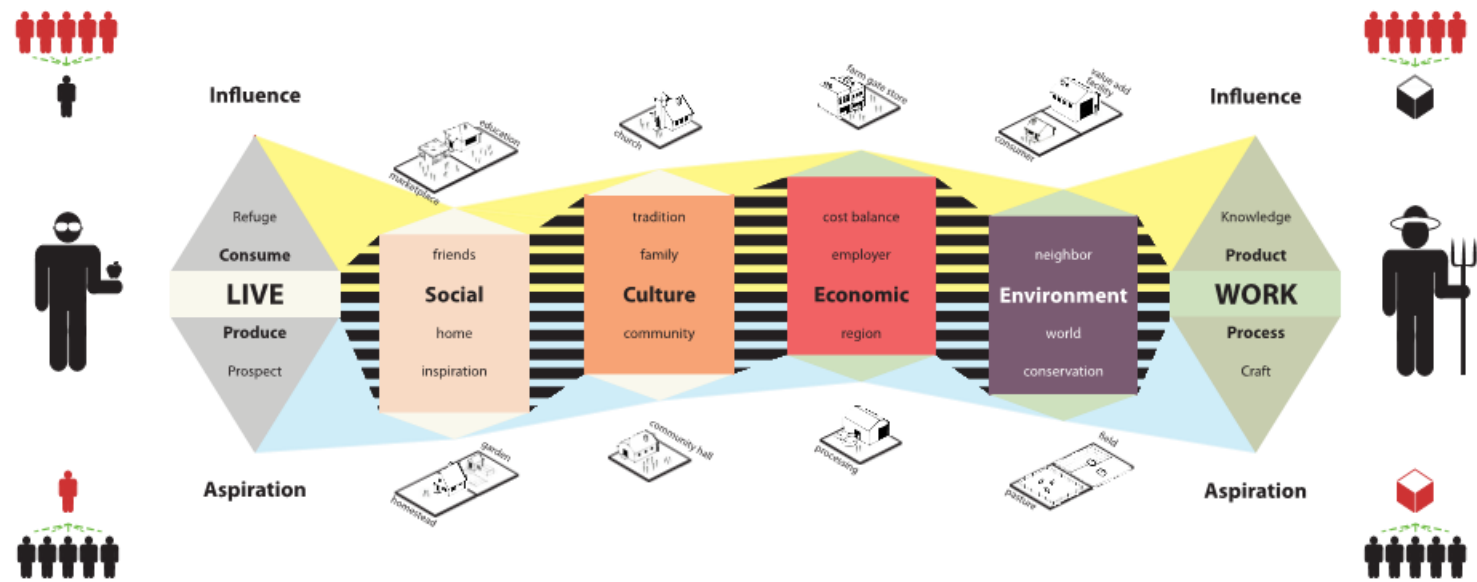

Value Adding the Consumer Experience.

Diagramming the intersection of rural typological anchors and producer/consumer. Many things push and pull the individual to produce or consume thus their effort to engage social, cultural, economic and environmental issues within the world.

transcend to the rural landscape given that resultant character of the industrial process is inherently modular in its configuration. Aldo Van Eyck developed the City Playground to be a socially regenerative architecture that could revitalize deteriorated urban conditions through minimal design intervention. The true virtue of City Playground is the architects success in developing a configurative architecture that attains multiplicity through the users free association of the built form to the urban fabric. If the consumer experience is to engage the individual in the place and occasion of the rural landscape, then the architecture must stimulate the imagination. As generational farms already mark a polycentric network across the rural landscape, they provide the perfect venue to develop the Aesthetics of Number theory.

Because the Twin Phenomena recognized that one form of architecture could not satiate the appetites of social and cultural evolution, and thus sought to design for the in-between; the reciprocity of the antonym. To solve the problem of aesthetics of number, Van Eyck developed a broad order

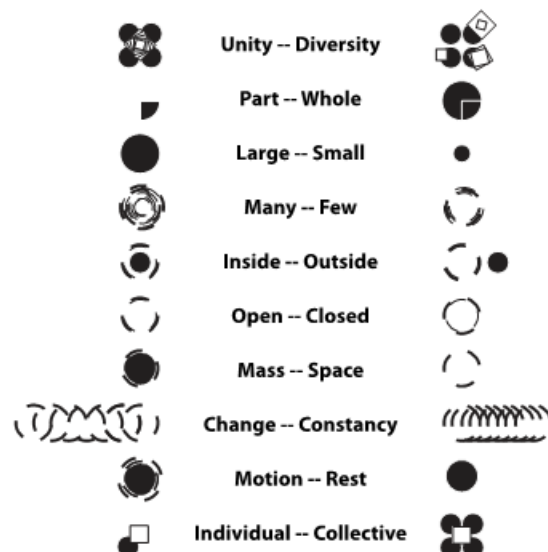



Modelling the Peripheral Experience.
To begin to understand the consumer experience, this model anticipates the individuals process for the interiorization of place and occasion through space and time; the merging of conscious and subconscious thought to define the present experience.

of antonyms that would initiate the design process.

To design for the multiple is to balance the antonym and define the elements necessary to support life, whilst allowing life to organize the sequence of growth. Wherein the consumer can freely interpret a material or form and interiorize that experience, the consumer is empowered to define the association of that material, form, or experience to their lifestyle demands. If the form is multiple, than the use is multiple, and can accommodate a greater range of tangible and intangible demands sought by the consumer.

From my research of industrial hemp as a building material, I have come to find that Hempcrete reveals the greatest opportunity for the architecture to explore the Aesthetics of Number problem set forth by Aldo Van Eyck. As a material resource integrally tied to the agricultural process and the principles of sustainability, Hempcrete will demonstrate its suitability to revitalizing rural communities because of the plants reciprocal nature. In that history has proven to abandon logic in favour of reason, is it possible for a new generation to abandon reason in favor of logic?

The Peripheral Experience

In same manner that Van Eyck saw the necessity to design the City Playground from the ground up, the rural landscape was built one farmstead at a time. With the rise of modernism and centralization of social and cultural services, the rural community fades into the periphery view of the average consumer. As the urban condition rapidly adjusts the identity of the individual to adapt to present conditions, basic knowledge and skill of self-sustenance is replaced by convenience, and thusly, the proliferation of industrial

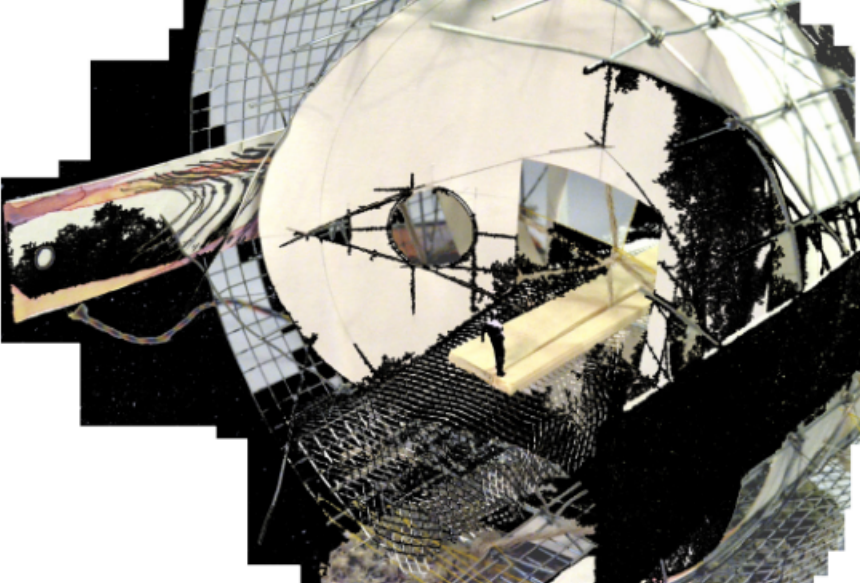

Modelling the Peripheral Experience.

The knot at the centre of the model represents the real time experience of the individual, a moment balanced by pre-existing, and the anticipated identity of the individual. In essence, the cage wire forms levels of experience and interpretation that engage the consumer in the experience.

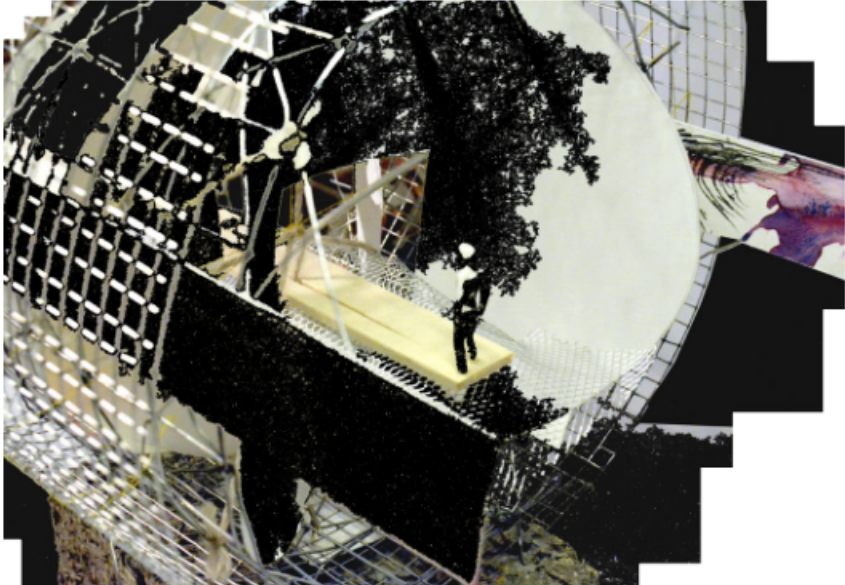

Modelling the Peripheral Experience.

As the individual moves through the landscape, they navigate a real and imagined environment simultaneously. The act of procession requires the individual to perceive future path from present environment and past experience.

The Peripheral Experience.

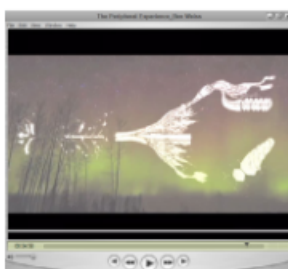

Animation frames ideas within a constantly changing environment.

agriculture. To bring the rural landscape back into the lifestyles of the urban consumer will make those producers resilient and necessary to the urban consumer. In utilizing the existing network of generational farms that maintain the rural fabric, the architecture can become germinal through its association to process.

When I discuss the Peripheral Experience, I am referring to the individuals sequential experience through space and time, and the inherent moments of twin phenomena wherein we simultaneously engage two realities -- one imagined and one concurrent. This is the moment that a visual, sound, taste, or sensation initiates a thought, and, through relative association we may recall a memory, or, through imagination we perceive a future experience. This moment of free association may be referred to as radical rationality, and is a moment where the conscious and subconscious intersect to produce an internal dialogue. Experience and anticipation play a significant role in the individuals creation of place and occasion, and becomes the primordial human attribute that drives us to produce and consume. As consumers most often experience the rural landscape through the automobile procession, I have created a video of that experience through Alberta's Prairie landscape. To view The Peripheral Experience, follow the link; <http://youtube/rDJej1X3ESg>.

When we consider the social or cultural customs that may inspire one community to develop sustainable building practices, a shared identity, and another to continue business-as-usual, another shared identity, we understand that the individual and community become one in the same.



Modelling the Consumer Tube

Given the hazardous nature of agricultural production, it becomes obvious that the consumer will require a vehicle to carry them through the rural landscape and local process. A derivation of the Peripheral Experience is the model for the Consumer Tube.

Conceptually, if the community sways the opinion of the individual via the peripheral experience - what is common or anticipated - than the emplacement of sustainable building practices could potentially sway a community to adopt those forms as convention. More so, if that architecture assists in establishing sustainable process, than subsequent generations will inherently carry on and refine that lifestyle.

Given the chicken and egg scenario, building a hemp network requires an industrial facility to operate efficiently, and, simultaneously requires the local producers to integrate a socially stigmatized fibre crop into their process. In any debate of the antonym, one must begin so that a dialogue will resonate, and through time, the argument is refined to logic and the in-between settles. Designing an industrial hemp facility in Warwick is not intended to save a few family farms, but benefits the collective identity of regional producers who may now access new revenue streams through sustainable products. This identity and the communities that produce it are strengthened by the consumers who may value or share that identity. What has proven to connect rural producer to urban consumer has always been the experience of the agricultural product.

As the initial step, the hemp facility could provide a raw material back to the producers who develop their own value added product for local consumption. What is required are the advertisements of the hemp product, living monuments to the plants natural and consumable attributes. Why not advertise with the building? Better yet, advertise how accessible and beneficial that product is to the consumer through the creation of a polycentric network.



Modelling the Peripheral Experience through the Consumer Tube
Given the hazardous nature of agricultural production, it becomes obvious that the consumer will require a vehicle to carry them through the rural landscape and local process. A derivation of the Peripheral Experience is the model for the Consumer Tube.

By allowing those rural producers to best imagine how that sustainable super crop moves from field to living form, the lifestyle becomes testament to how that process has bettered the rural fabric and instilled a new sense of creativity. When everyone becomes an artist, no one works any more.

To be concise, the Peripheral Experience will develop the notion of the in-between space as catalyst for the individuals personal growth - the moment that the individual rationalizes the twin phenomena, a split reality. Much as the network of sustainable farm structures will create a galaxy for consumer experience, wherein any chance intersection of rural process and consumer experience is facilitated by one or many architectural elements, the architecture itself must become the in-between. Given that the automobile has become embedded in North American culture, it becomes the primary vehicle through which the urban consumer will experience the rural landscape. Because safe driving requires the operator to focus attention to the forward motion of the vehicle, the rural landscape is only experienced at a distance and high velocity, falling to the periphery vision and from memory.

The moment that an object falls into the periphery vision, the viewer must adjust focus to regain the vision, or, may conceptualize the object from past experience. Because the object was in sight long enough to spark interest, the interest inspires thought - dialogue from thin air. If the vision was brief enough that the viewer cannot fully comprehend the event, then the dialogue requires reason and the viewer is now engaged in a thought process that utilizes association and imagination to fill in the blanks. The nature of technology

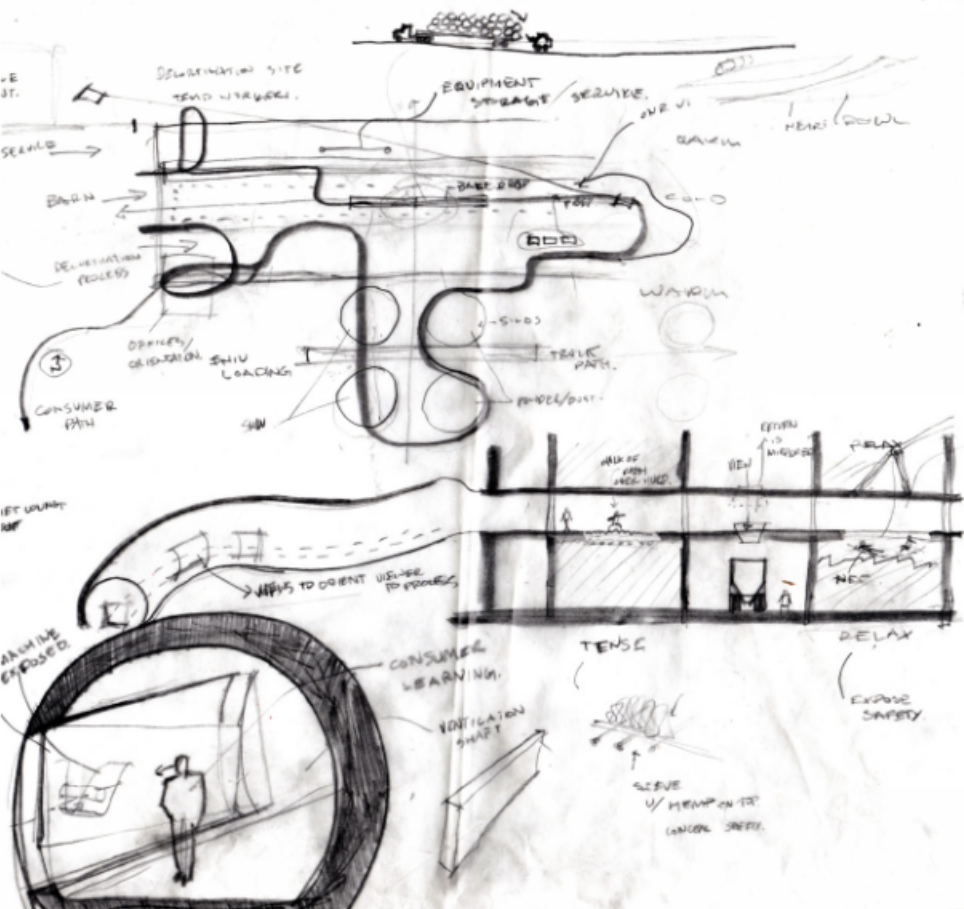

Schematic design of the Consumer Experience; Sketch



⊗ 1

Environmental Product - Water



⊗ 4

Agricultural Product - Hemp Shiv



⊗ 1

Industrial Product - Hydraulic Lime

Recipe for Hempcrete.

and its integration into nearly every aspect of human life has made mechanization frequent and common, a passing thought. As the consumer experiences a visceral image of the industrial rural landscape, the periphery is filled with machines that represent the agricultural process - the rural producer fades to the periphery.

What is needed is an architecture and an agricultural process that can effectively engage the consumer interest long enough to spark dialogue. A material, form and program that integrates into the consumer experience and fills the periphery. Because of Hempcrete's suitability and plasticity as building envelope, it can be used to guide the consumer's procession as built form. The continuous exposure to Hempcrete simultaneous to the consumer's education of the material's sustainable character will establish a clear perspective of the product in relation to the individual - the interiorization of material to create place and occasion.

The Consumer Experience

As discussed, the most successful integration of the rural and urban landscapes will depend upon the consumer experience through a local producer's process. The relationships that grow from common values of landscape, process and product are intended to validate the role of generational family farms for sustainable Live/Work/Play communities. If the architecture is to become the catalyst for a re-imagined rural landscape, a landscape that exhibits principles for sustainable community lifestyles and not the landscape that is dependent upon industrial agriculture, then the architect must reimagine the rural process that reciprocates the natural landscape. As Aldo became



Modelling the Consumer Tube.

The Consumer Tube Facilitates the guided procession of consumer through rural experience. The modular development of a sequential element allows for the sequential engagement of the consumer and rural producer, and will facilitate the direct exposure of the consumer to agricultural product.

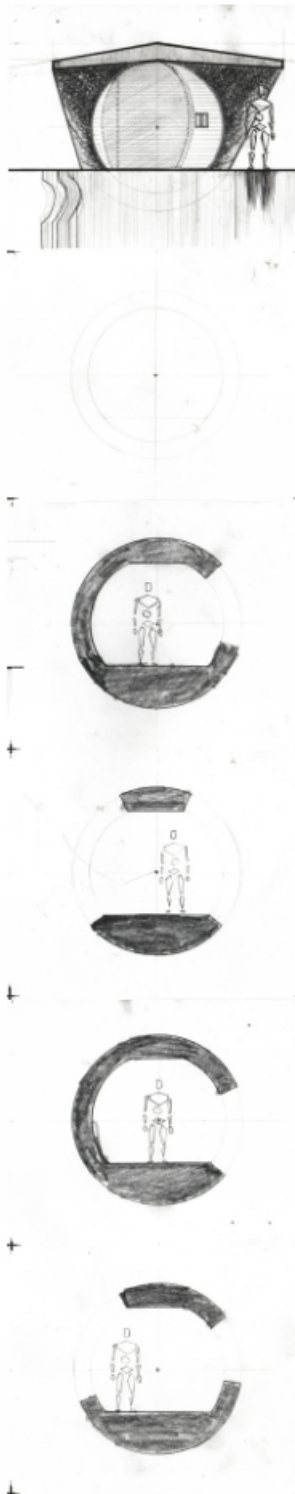

Guiding the Consumer Experience through the agricultural process.

an architect/urbanist to approach configurative design, and farmers inherently become everything their process demands, then the architecture will require an architect/urbanist/entrepreneur that can mediate the principles of sustainability to rural communities.

A critical social evolution that has changed the relationships between rural producers and urban consumer is the radical associations that individuals attach to products. This is to say that consumers demand products with greater experiential value, and thusly, the growing dependency on technology for entertainment. How does an apple compare to a computer? The basic values of the food commodity fall to the periphery. If the agricultural process is to regain essential relationships to urban consumers, than the farmer must become entrepreneur to fill the experiential demands of the urban consumer. If those demands can be made through sustainable practices, than shared identity via experience of product is value-added, and the experience of the sustainable producer/consumer identity can be extended through the consumers social network.



Relativity and Imagination in Future Foodscapes.
A perspective of future events if industrial process continues unhindered. To awake the average consumer from their 'business-as-usual' lifestyles will require jolting visuals. A virtue of art is the necessary critique of social normalcy and the resultant human nature - a sensualization of the argument.

Section 3: Radical Rationalization

The relativistic world view includes transcendence; *sine qua non*. The subjectivation of measurability. Every expression that the rhythm of such a worldview in art or science excludes one-sided rationalism, because it accommodates the rigid polarity between object and subject within their ambivalence.

-Aldo Van Eyck⁷¹

The merger of architecture as consumer product ultimately rose with the co-development of modernism and the industrial manufacturing processes that dominate the conventional building industry. Most consumers do not seek the architects service for their own notion of homecoming as the urban context provides many alternatives for the urban lifestyle as a result of service proximity. This is to say that the conventional urban model is successful because the urban consumer has direct access to all of their desired product and experience, and can facilitate their Live/Work/Play mode of lifestyle immediately. However, the limitations of the urban fabric hinder the application of radical design influence that does not fit the context. Conversely, the rural landscape is not hindered by the same limitations to growth of local process as a continuous revision of the socio-technical convention happens with every new cycle. Where architectural design may face urban constriction, the rural landscape provides freedom of process. Given the vastness of the prairie landscape, its obvious that the farmstead becomes epicentre of a shared lifestyle and the catalyst for sustainable community growth.

So as not to oversimplify the generational family farm, the complex network of systems that support the rural lifestyle demand cooperation between the design

71. Van Eyck, et. al., *Writings*, 151.



Hempcrete

Biofibre Panel

Hemp Fibre Insulation

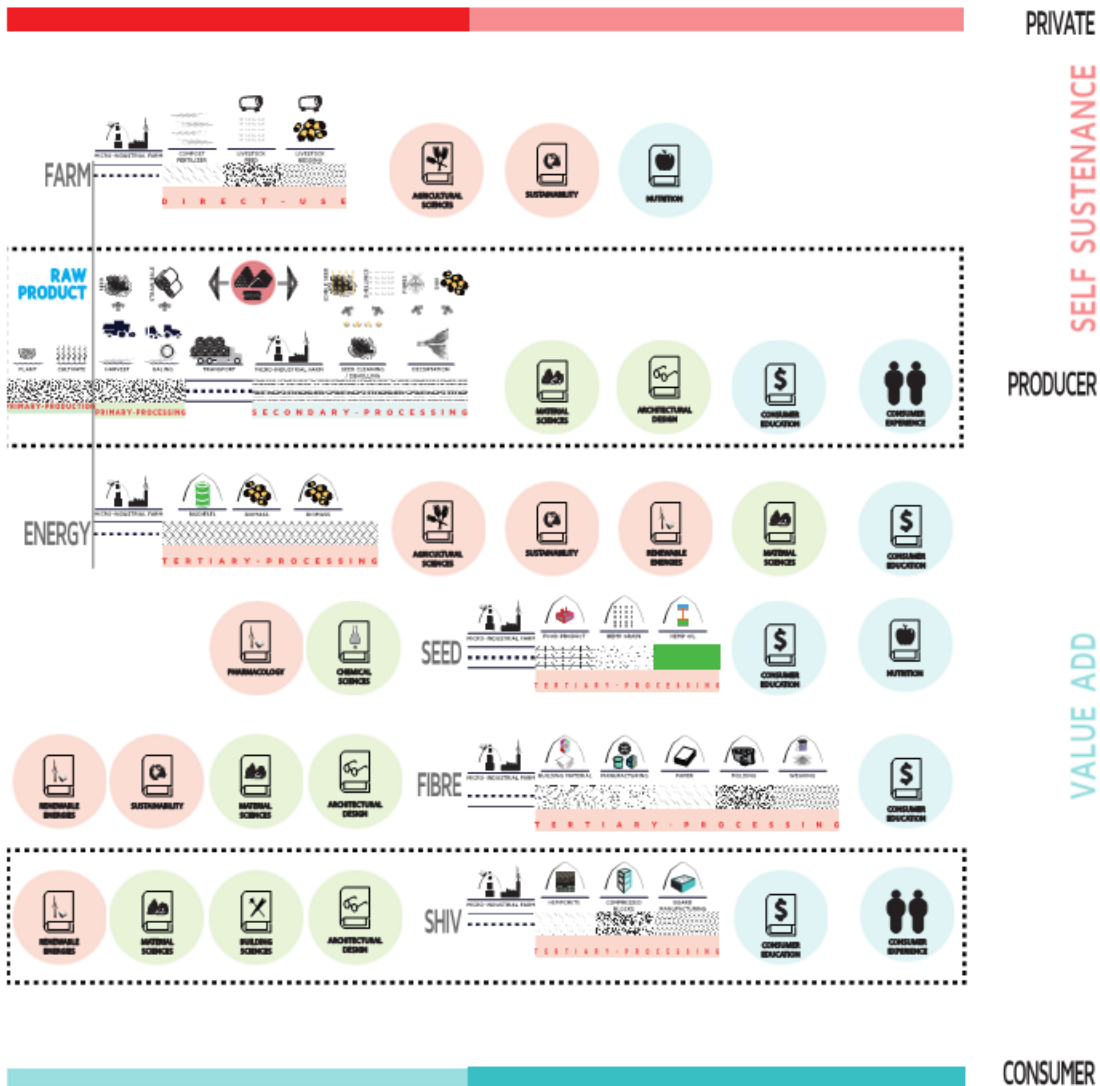

Diagramming the potential for Community Resiliency; hems dexterity as a design and product medium can meet the demands of multiple industries and processes, ensuring consumer uptake.

professionals that regulate those systems. In developing a cohesive language of design that can be understood between professions and across the urban/rural divide requires the expertise of the architect. Together, designers can employ theoretical and tested concepts agricultural process, product design and sustainable community development; and must oppose the convention of design knowledge isolation. If the industrial agricultural aesthetic reveals any lesson, it is that many separate ideas and systems exist to support the agricultural process, yet remain as disparate objects that celebrate technology above nature. The elements that become resilient develop influential social and cultural value that is retained for future generations, much like the antique, and the foreboding lesson of the antique is that it is no longer of any significant purpose other than to recall experience. The radical objective of this thesis, of the architecture, is to prevent the erasure of our rural lifestyle.

When considering the agricultural process designed in consequence of an industrial food system, it is evident that producers dedicated to their agrarian principles reacted by privately mobilizing grass root movements for organic and locally sourced food production. Whatever efficiency or advantage in quantity afforded by the industrial agricultural system was countered by the reduced quality of the product. This spawned an entire market for food products valued for their ethical material production. These niche food markets are entirely designed at branding products for their quality and consumer experience. As rural landscapes continue to support the industrial agri-business complex, small farms must modernize at great capital cost or die out. Small pockets of agrarian lifestyle resist the tides of change in

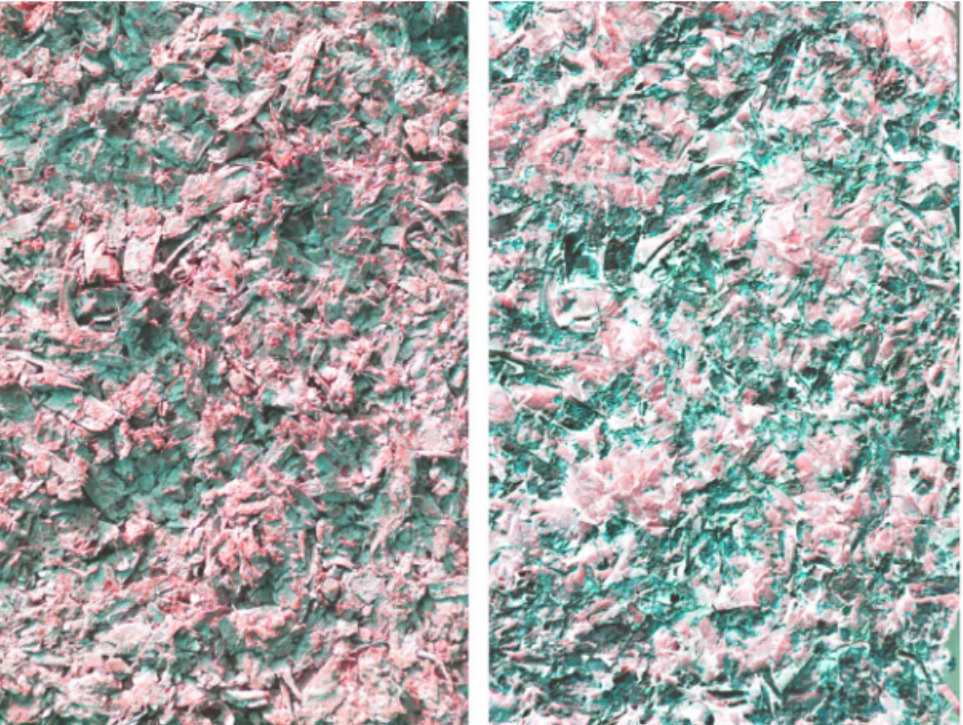
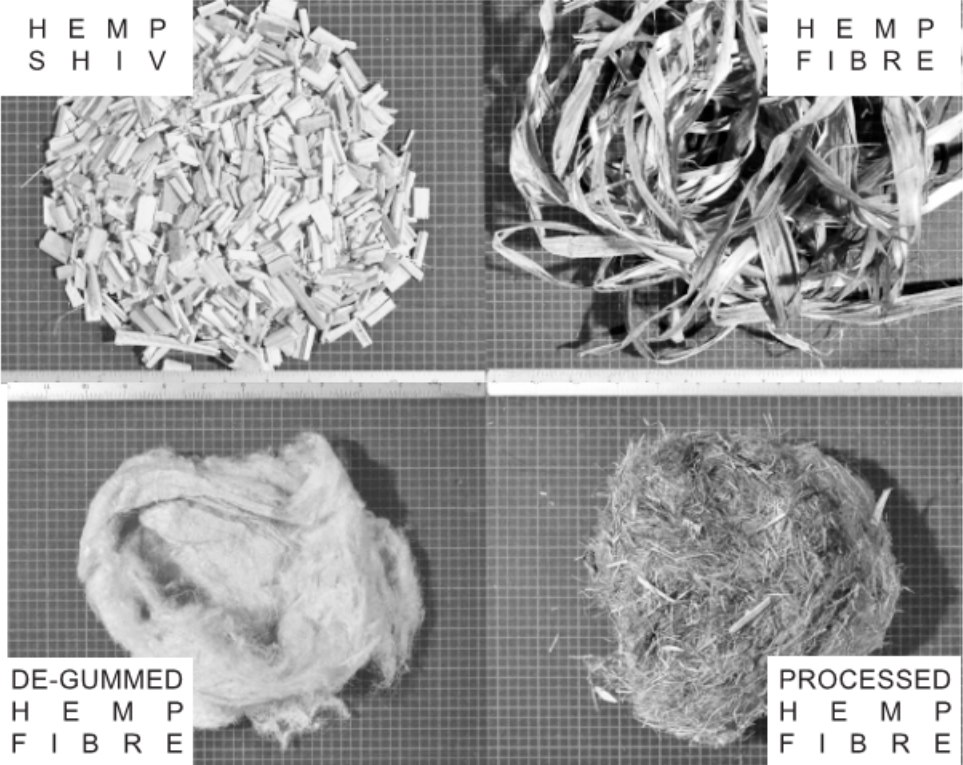

The by-products of the decortication process (clockwise from top left); hemp shiv, primary hemp fibre, refined hemp fibre, degummed hemp fibre. The texture of the Hempcrete wall is reminiscent of the highly textured rural landscape.

Alberta by producing a value added product sought by local consumer markets. These niche markets fill a void in the local economy and stand as symbols for the resilient family farm, capable of adopting material cycles and producer craft to the product in demand. The ability of the family farm to adapt to changing community need is testament to the farmers' integrity towards maintaining the family farm lifestyle.

Foodshed, by Dee Hobsbawn-Smith, details the efforts of rural Albertan producers who have developed value-add food products and farmgate stores so their generational farms become resilient. In creating their production process to meet the needs of a local market, producers develop a product that the communities can constantly utilize, creating a sustainable economic cycle and shared identity. The advantage of a community integrating hemp production into their agricultural process is that it allows the community to adapt their material culture to more closely align with the principles for sustainable communities. When considering the deeper poetry that urban populations attach to the agrarian lifestyle, the family farm is a considerable opportunity in demonstrating to the consumer how the potential of renewable energies and sustainable material processes may contribute to the collective identity of the landscape. In creating a design language capable of integrating the disciplines of engineering, planning, community design, social engineering and material production, the designer is able to develop an enhanced consumer experience.

There is cultural significance to integrating the consumer experience into the material process of wine

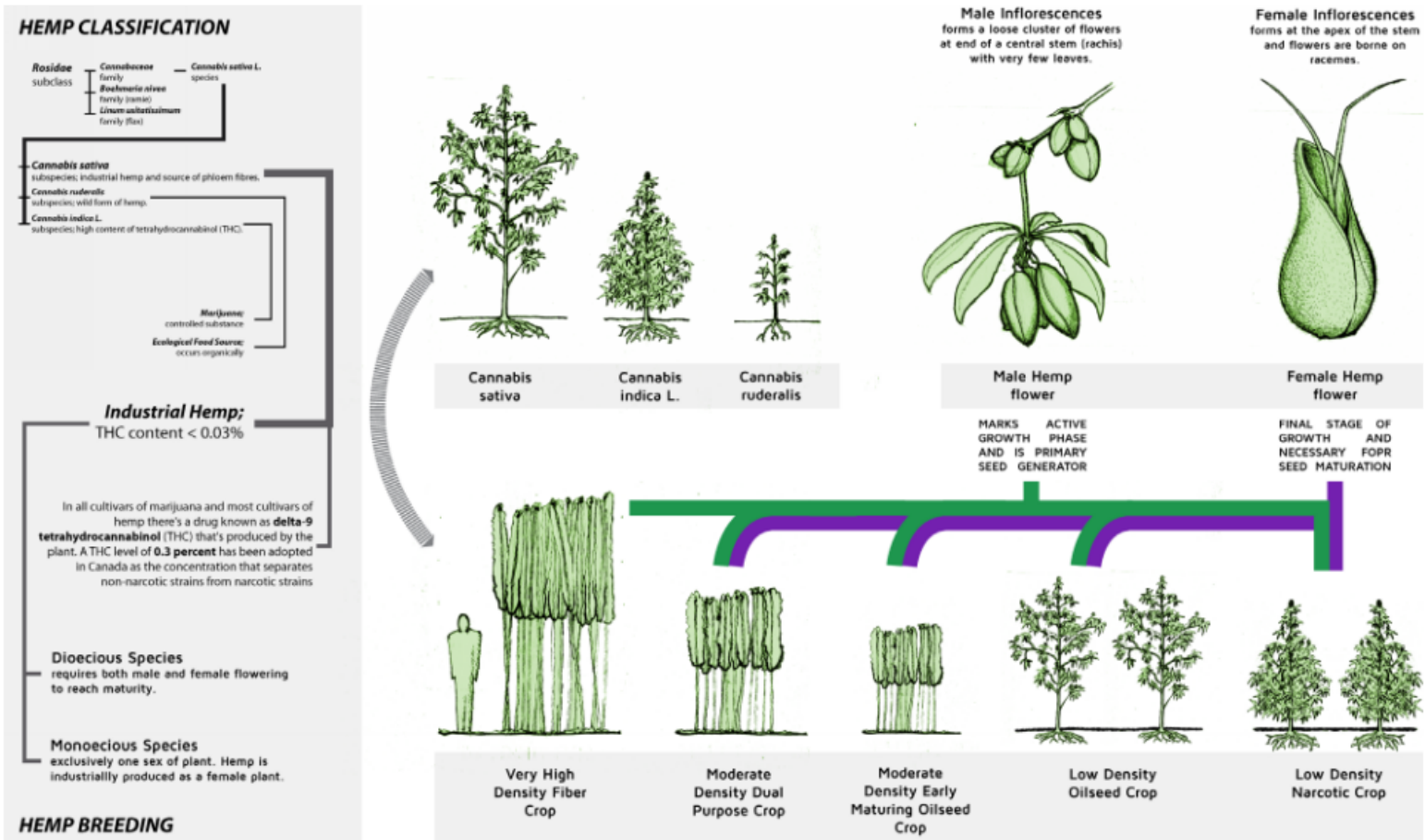

Hemp Classification.

To successfully integrate the production of hemp into the rural landscape will require the desensualization of existing stigmas surrounding the plant through the education of the plants qualitative attributes and direct correlations to its sister plant, marijuana.

production, a method of brand building used to increase product sales and customer loyalty. So what happens when a common, everyday product is exposed to the consumer, and the material process is passed from producer to public? How can designers align the consumer experience to the material process and achieve a greater social message about sustainable production?

As rural landscapes are replaced for the industrial, the craft and knowledge of local process is lost, and consumers become increasingly dependent upon concealed mechanisms of production. Consumers require an experience that gives them a real ability to manifest an idea, a principle or process through the vehicle of material production. If that skill is crafted on the basis of sustainability, then the advancement of that process will forever exhibit principles for energy conservation.

Following are the theories and opportunities that can assist the architect in designing a re-imagined agricultural process for the prairie landscape. As rural systems are the integration of natural and anthropogenic networks, often conceived to be beyond the realm of the architect, the language of the planner and engineer resound. The role of the architect is to then interpret the new systems that rural producers could implement into their existing process and network with little difficulty. Furthermore, the architecture initiates a dialogue between the producers process and the individual -- as clear associations between process, medium and reward develop. This section of research will explore real networks of production and current models of sustainable community design so the architect is concise in

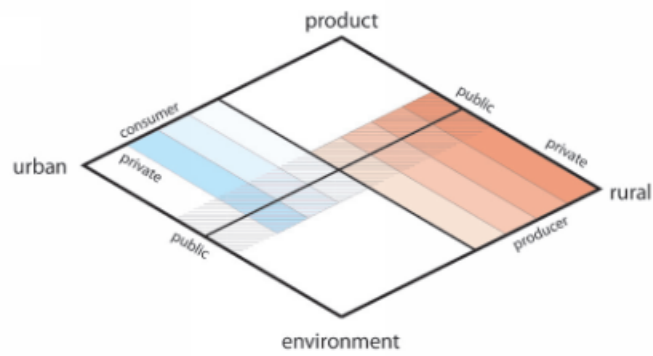

The rational application of resource planning to urban design has concentrated social and cultural programs within urban environments. In light of the prosperity that industrial agriculture has afforded the urban realm, it has reduced the significance of food production to a minor thought in the mind of the consumer. This has led to a lapse in collective thought regarding the environmental, social, cultural and economic costs that our food consumption accrues, and inspires a new architecture that can connect consumers to the landscapes they inhabit.

Rural Systems & Typological Anchors

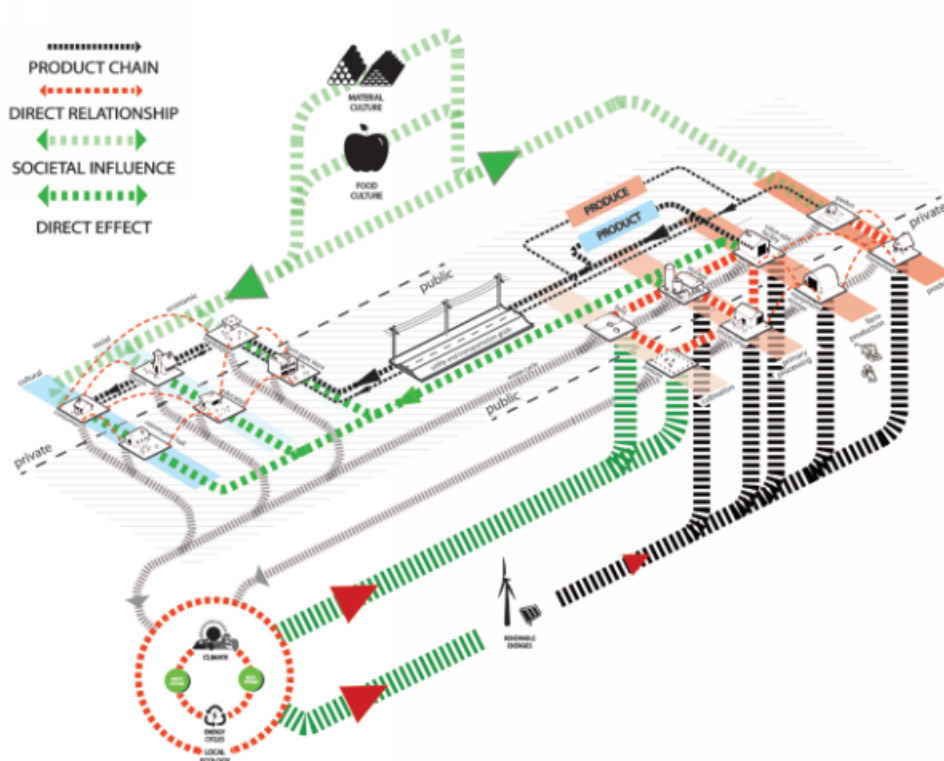

Excerpts from the Sears and Roebuck Barn Catalogue reveal the wealth of construction knowledge which existed in the pre-industrial landscape.

their design strategies.

Actor-Network Theory

The culture of particular form is approaching its end. The culture of determined relations has begun.

-Aldo Van Eyck⁷²

Actor-Network Theory (ANT) is how the architect will approach urban studies and the role of community designer, wherein associations between urban and rural lifestyles can be defined. To be clear, ANT is not a theory, but "... a certain sensibility towards the active role of non-human actors in the assemblage of the world, towards the relational constitution of objects, and the sense that it all calls for symmetrical explanations."⁷³ Three principles for advancing urban studies comprise ANT, considered advanced because they are the tools of contemporary social science; radical rationality, generalized symmetry, and association.⁷⁴

Radical Rationality - A principle of relationality beyond language, beyond culture, and beyond communication to all entities; ... Human and Non-Human are considered to be mutually exclusive (ie. objects, tools, texts, technologies, formulae, institutions, etc. ...).

Generalized Symmetry - A methodological principle sustaining radical rationality by creating a common conceptual repertoire to describe and analyse relations between humans and non-humans.

72. Van Eyck, et. al., *Writings*, 136.

73. Farias, et. al., *Urban Assemblages*, x.

74. *Ibid.*, x.

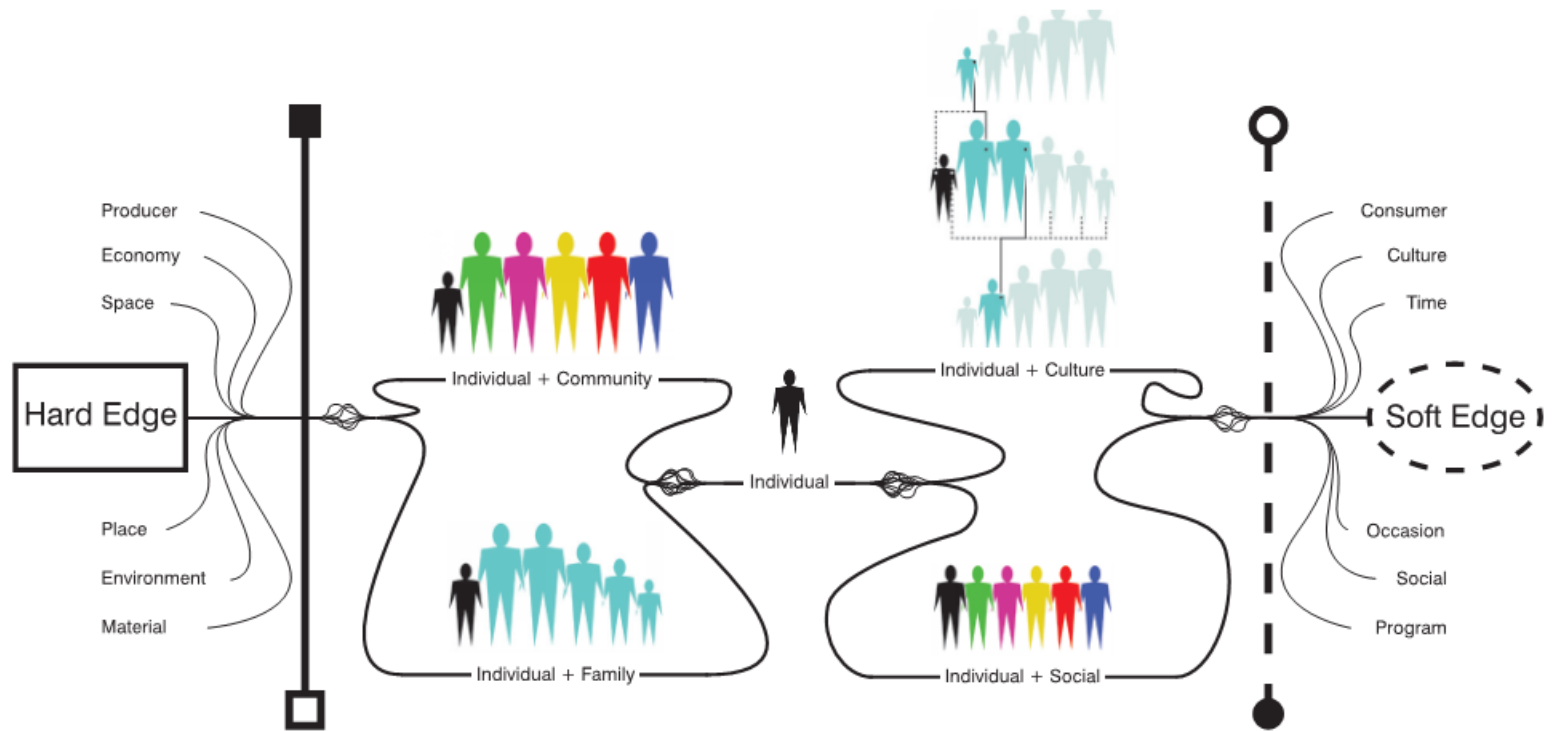

Networks of Configurative Identity.

Hard edge refers to the tangible environment, soft edge refers to the intangible environment.

Association - As human and non-human become actants in a social dynamic, the social is considered the 'association between things.' The social is thus not a thing but a type of relation, or better, associations between things which are not social by themselves.

Foremost, the articulation of ANT for the purpose of advanced urban studies has resulted in a greater understanding of anthropogenic development, and the ability of association to become reason for preservation. The development of the association is then dependent and the work of Annemarie Mol provides an accurate understanding of how objects are brought into being through enactment;

Similar to the notion of performance (of subjects), the enactment of objects, such as city is not just social, but also material, and involves the heterogeneous ecologies of entities acting at sites and contexts of practice.

- Annemarie Mol⁷⁵

This is to say that the city is an assemblage of multiple realities, being enacted here or there, now and then, and asserts the Bergsonian concept of a multiplicity of reality; through time and space the same object proves made evident by the industrialization of the agricultural process, and the interpretations of urban development can be assimilated with the rural landscape. Following is a quotation intended to describe the multiplicity of the urban condition, but when contextualized to the rural, the similarities of urban and rural growth are revealed.

The city is made up of potential and actual entities/ associations/togetherness ... the accumulation of these entities can produce new becomings - because they encounter each other in so many ways, and because they exhibit 'concrecence.'

75. Ibid., 13.

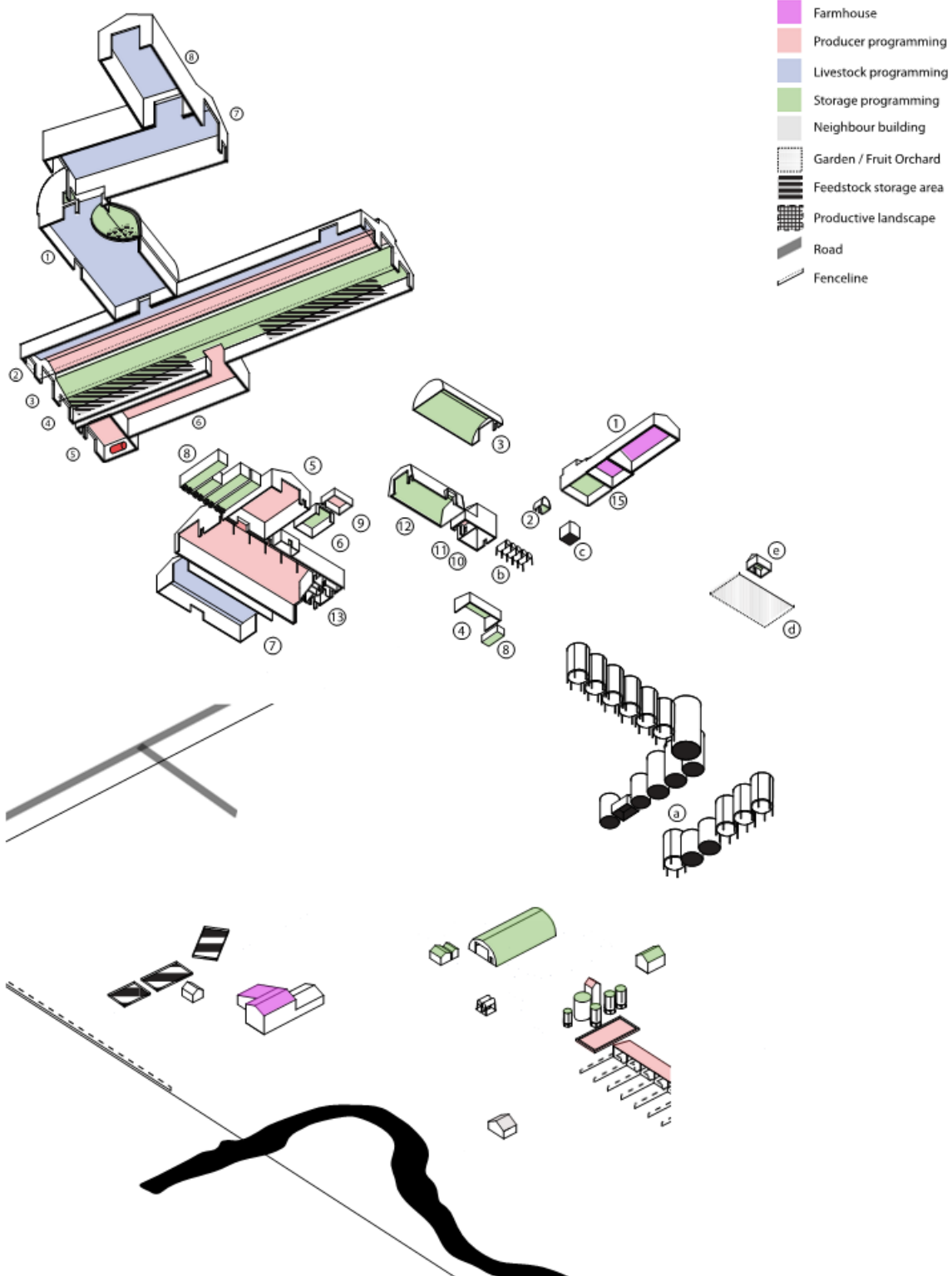

The learned behaviour of construction through the generational farm. The Offspring farm has yet to define its role in the landscape and becomes the venue for sustain

- Amin and Thrift⁷⁶

This quote easily transcribes the rural condition and the actants which continuously reinvent themselves as a mode of preservation. Given the reciprocal nature of the urban and rural condition, it seems natural that they become a synonymous association and the basis of a designed consumer experience. ANT is employed as a metaphysical interpretation of the rural landscape that the architect will represent via the consumer experience.

Architecture without Architects

The old struggle between imagination and reason has ended in a tragic way. The result is disconcerting. The triumph of reason has systematically broken every relation, disturbed every balance. A wedge has been driven between nature and man with foolish tenacity. And as for art: she was degraded into a mirror of vanity ...

Imagination is and remains the only faculty capable of registering the qualities of a changing worldview simultaneously ...

-Aldo Van Eyck⁷⁷

Observations of the Grandparent and Parent farm process reveal that farmers are very much a form of architect. Although they are not practiced in the professional sense of the word, the rural producer does apply skilled knowledge of building systems to assist local process. Given the multiplicity of built form via common process, the development of a new rural architecture does not require radical form or architectural concepts, but must respond to producer need and ability. Ultimately, the built form that the rural producer raises will be the result of meticulous strategizing and the greatest conservation of energy.

76. Ibid., 14.

77. Van Eyck, et. al., *Writings*, 150.

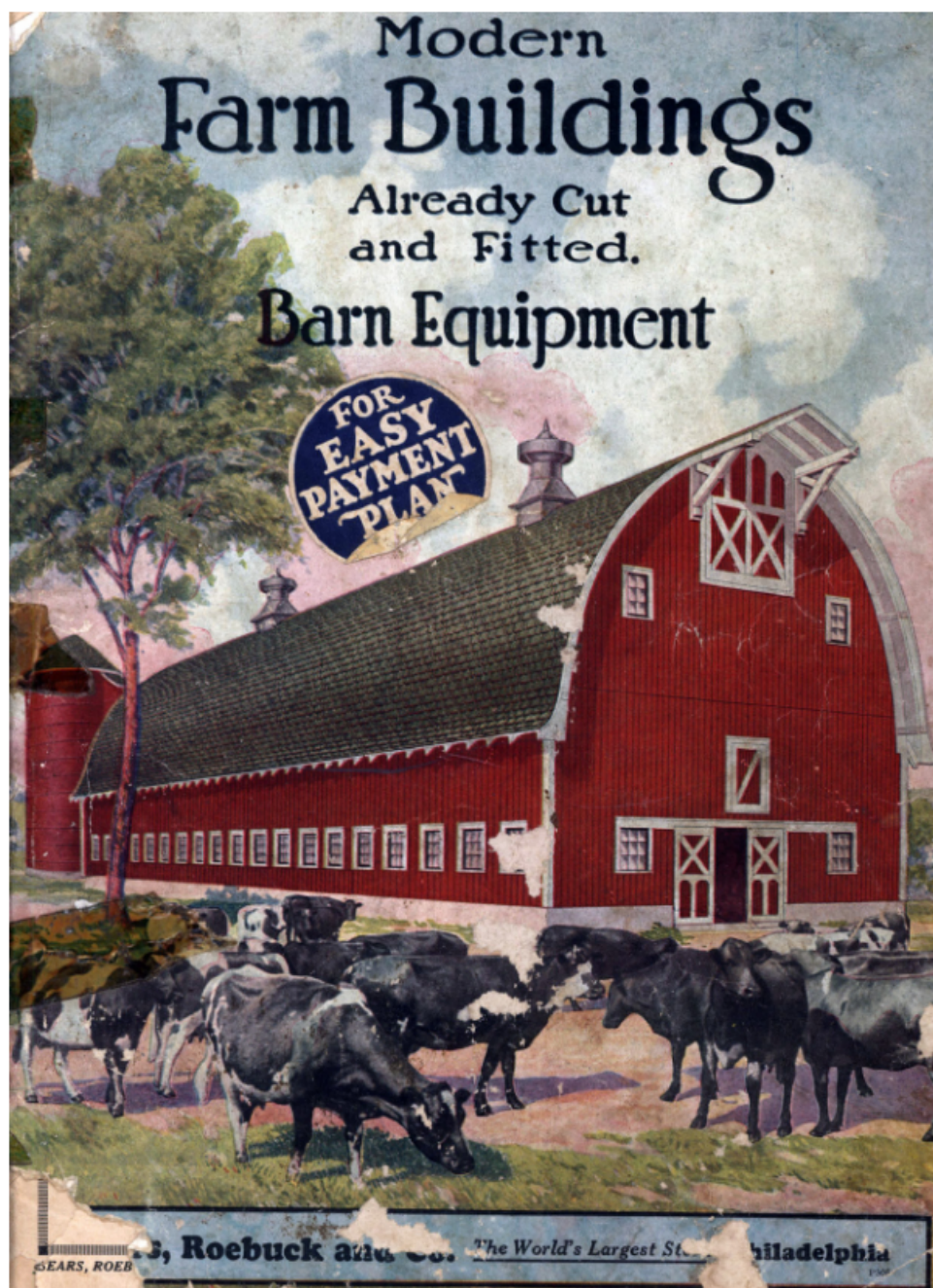

Vernacular Trade Catalogue.

Trade catalogues became a tool for rapidly developing the rural landscape, allowing rural producers to modernize operations to industry conventions.

Image Source; Sears, Roebuck and Co. 1928. *Trade Catalogue: Modern Farm Buildings already cut and fitted: barn equipment*. Chicago: Sears Roebuck and Co.. <https://archive.org/details/SearsRoebuckCoModernFarmBuildingsBarnEquip0001>



Vernacular Trade Catalogue.
Architects Council.



Vernacular Trade Catalogue.
Selling the build.

However, the rural process is inherently subjective to the producers understanding of energy conservation, and often they assimilate existing building conventions for economic and time constraints.

In my research of how architecture has engaged the agricultural realm, I was fortunate to uncover two juxtaposing modes of architectural design that explain the multiplicity of built form within Alberta's rural landscape, and the other that explores modern intersection of architectural design and the producers local craft of built form. What resulted in the Grandparent farms agglomeration of distinctly programmed built forms was the result of the widespread dissemination of common building conventions, via the mail-order catalogue. Because these structures became so multiple and recyclable, the rural landscape did not invest in the preservation of these structures, seeking more modern, resilient materials and prefabricated form. The Barn catalogue reveals the precedent for the standardization of farm building program and form via the dissemination of dimensional lumber building conventions. As well, exploration of the design-build process enacted by the architects at Bruder Klaus Field Chapel will reveal how local building craft can enact the sensualization of the rural landscape.

Barn Shopping & the Bruder Klaus Field Chapel

Build your Barn like a Skyscraper.

-Sears, Roebuck and Co., Trade Catalogue⁷⁸

With the proliferation of agri-business and the dissemination of agricultural conventions, the collective identity of the rural producer was strengthened as local

78. Sears and Roebuck, *Modern Farm Buildings*, 1928.

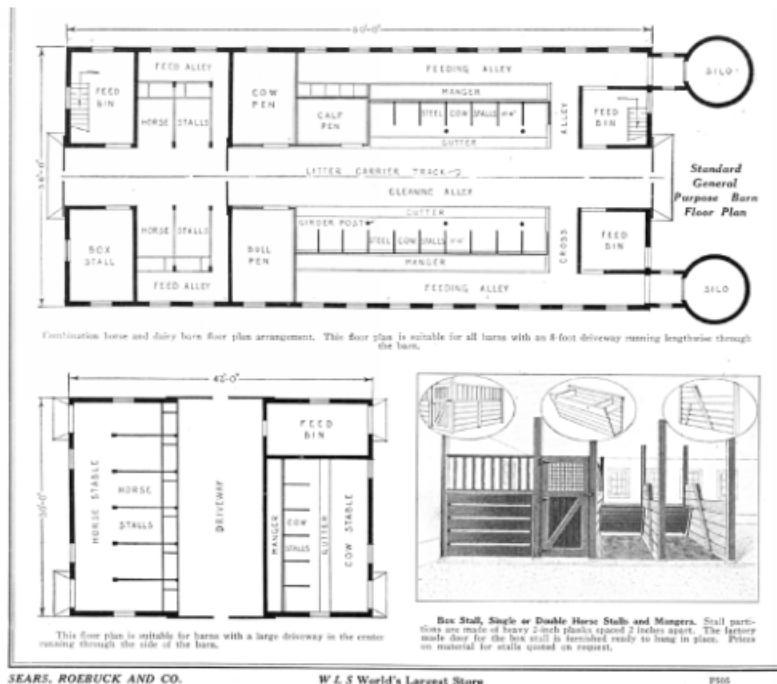

SEARS, ROEBUCK AND CO.

W. L. S. World's Largest Store

P505 7

Vernacular Trade Catalogue.

Simple form and simpler construction, the pre-industrial agricultural building aspired to sustainable principles of agricultural process and reconciled modern building technologies simultaneously.

Image Source; Sears, Roebuck and Co. 1928. *Trade Catalogue: Modern Farm Buildings already cut and fitted: barn equipment*. Chicago: Sears Roebuck and Co.. <https://archive.org/details/SearsRoebuckCoModernFarmBuildingsBarnEquip0001>



Vernacular Trade Catalogue.
Building Machinery.

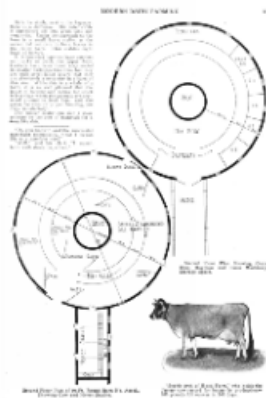

Vernacular Trade Catalogue.
Agricultural Programming.







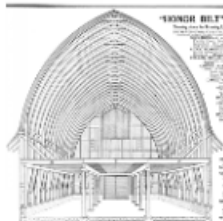

Vernacular Trade Catalogue.
Mail-Order Industrial Equipment.

networks defined vernacular built forms in response to ecological process. The virtue of the barn catalogue is the documentation of standard building designs and technologies that have become so common that they reach the point of prefabrication. Because the farmer could quickly assess the potential of built form against their local process needs, the Barn catalogue became the medium through which agricultural producers could re-imagine their rural landscapes. As the farm building can be distinguished as a generically programmed structure that separates exterior process from the interior, the complexities of those exterior processes are often determined via the investment into the interior process.

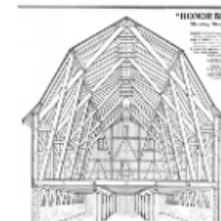
The reason that the Barn Catalogue was successful in standardizing farm building form during the Grandparent generation was arguably the result of the catalogues representation of intricate building details that concern architect and farmer alike; ie., cost, labour requirement, and construction material availability. This is to say that the rural producer has already made themselves competent in a variety of mediums, and as such, will expect a competent appraisal of the existing rural condition and realistic interventions derived from the landscape. Realistically, one form of building does not regulate the agricultural process, but requires an assemblage of built forms to validate the interior and exterior agricultural process. Thusly, the objective of the architect is to assess the built form in response to agricultural programming conventions. If the design is to appear competent, it must provide realistic intervention strategies that speak to preserving the validated agricultural process yet advance the material culture that



 <p>"HONOR BILT" SPECIFICATIONS Gothic Roof Barn Clear Span of Barn 36 Feet wide Clear Height of Barn 36 Feet 10 In.</p>	 <p>"HONOR BILT" SPECIFICATIONS Gambrel Roof Braced Rafter Barn Clear Span of Barn 36 Feet 10 In.</p>	 <p>"HONOR BILT" SPECIFICATIONS Gambrel Trussed Roof Barn Clear Span of Barn 36 Feet 10 In.</p>
 <p>"Cyclone" Modern Barn No. 3024 \$968⁰⁰</p>	 <p>"Greenfield" Modern Barn No. 3028 \$1,128⁰⁰</p>	 <p>"Economy" General Farm Barn No. 5298 \$852⁰⁰</p>

Vernacular Trade Catalogue.
 Excerpts from the Sears and Roebuck Barn Catalogue reveal the wealth of construction knowledge which existed in the pre-industrial agricultural landscape.

Image Source; Sears, Roebuck and Co. 1928. *Trade Catalogue: Modern Farm Buildings already cut and fitted: barn equipment*. Chicago: Sears Roebuck and Co.. <https://archive.org/details/SearsRoebuckCoModernFarmBuildingsBarnEquip0001>

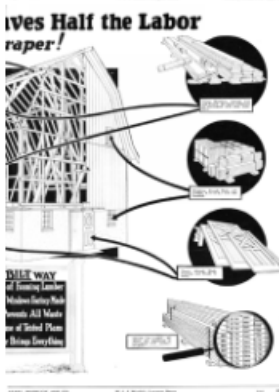
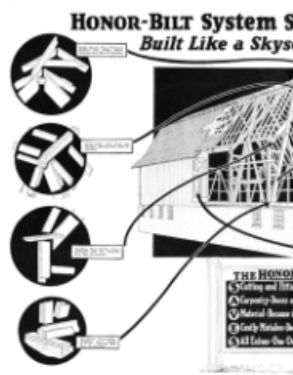

Vernacular Trade Catalogue.
The Devil is in the Detail.



Vernacular Trade Catalogue.
Urban Farmstead.

persists through the subjective knowledge of built form. Given the enormity of erecting a generational family farm in the modern rural landscape, the architect will anticipate the rural producers as self-builders that can incrementally build their operation over time.

In order to design buildings with a sensuous connection to life, one must think in a way that goes far beyond form and construction.

- Peter Zumthor⁷⁹

As the farm operation grows with the family farmer, the addition and subtraction of agricultural structures is inherently subjective and directly responds to need. In attempting to preserve a built form that associates directly to process, the process must first be validated via the conditions of the landscape. Similar to the notion of the urban and rural synonym, the built form of the agricultural process is synonymous with the rural landscape, and thusly the condition of the landscape would validate the process of the built form or vice versa. Ultimately, the built form will become the determinant of the consumer experience but must remain true to the purpose of the rural producers efforts; their lifestyle. To understand how the architect may engage local process to inspire form, I look to Peter Zumthor's unique design-build project of the Bruder Klaus Field Chapel, located within the rural landscape Mechernich, 55km from Cologne in the west of Germany. The following are excerpts from a digital article which accurately describe the resultant process and form of a vernacular architecture.⁸⁰

Arguably the most interesting aspects of the church are

79. Archdaily, *Bruder Klaus Field Chapel*, 2011.

80. Ibid., last modified 2011.



Bruder Klaus Field Chapel.

Procession of monument through the in-between space. Form and material transcend the natural landscape into monumental mass - inhabit the building as you inhabit the landscape..



Image Source; Ludwig, Samuel, and Mayer, Thomas. 2005-2007. *Bruder Klaus Field Chapel*. Photograph. Mechernich, Germany: Archdaily. <http://www.archdaily.com/106352/bruder-klaus-field-chapel-peter-zumthor>



found in the methods of construction, beginning with a wigwam made of 112 tree trunks. Upon completion of the frame, layers of concrete were poured and rammed atop the existing surface, each around 50cm thick. When the concrete of all 24 layers had set, the wooden frame was set on fire, leaving behind a hollowed blackened cavity and charred walls. The unique roofing surface of the interior is balanced by a floor of frozen molten lead. Gaze is pulled up by way of obvious directionality, to the point where the roof is open to the sky and night stars. This controls the weather of the chapel, as rain and sunlight both penetrate the opening and create an ambience or experience very specific to the time of day and year.

On a sunny day, this oculus resembles the flare of a star that can be attributed to a reference of Brother Klaus's vision in the womb. The very somber and reflective feelings that become inevitable in one's encounter with the chapel make it one of the most striking pieces of religious architecture to date. The field chapel is dedicated to Swiss Saint Nicholas von der Flue, known as Brother Klaus. It was commissioned by farmer Hermann-Josef Scheidtweiler and his wife Trudel and largely constructed by them, with the help of friends and craftsmen on one of their fields above the village.

- Peter Zumthor⁸¹



Bruder Klaus Chapel provides considerable precedent for the technological application of a material sequence to a local process. Farmers designed and erected the natural log form work which denotes the positive interior space. Concrete is cast incrementally onto the form work, as far as the sequential process allows, and preserves the spiritual intensity of the farmers craft. When the log form work is removed, analogous to the disappearance of local craft, visitors may revisit and experience the knowledge of the farmer within the elemental concrete casting of its positive form. This chapel embodies the design principles which foster the consumers experience of local producers process. The message of the building is clear and rings in the hearts of visitors; an intense spiritual connection to natural



Bruder Klaus Field Chapel. Monument within the rural landscape.

81. Ibid., last modified 2011.

Open Air Ceiling isolates the viewer from sensorial interruptions. Focus is on water and light travelling through air.

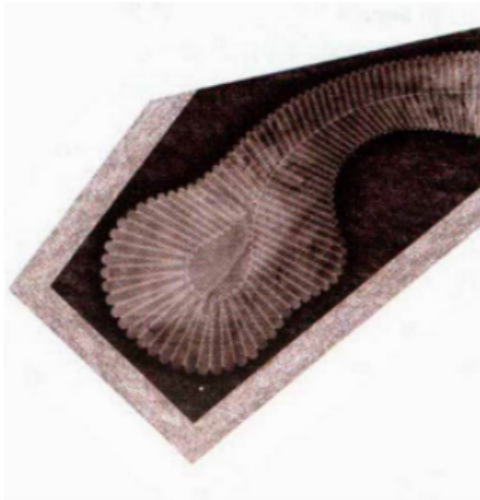

Plan drawing by Peter Zumthor.

Formwork through local process of construction displays a vernacular building typology become cultural.

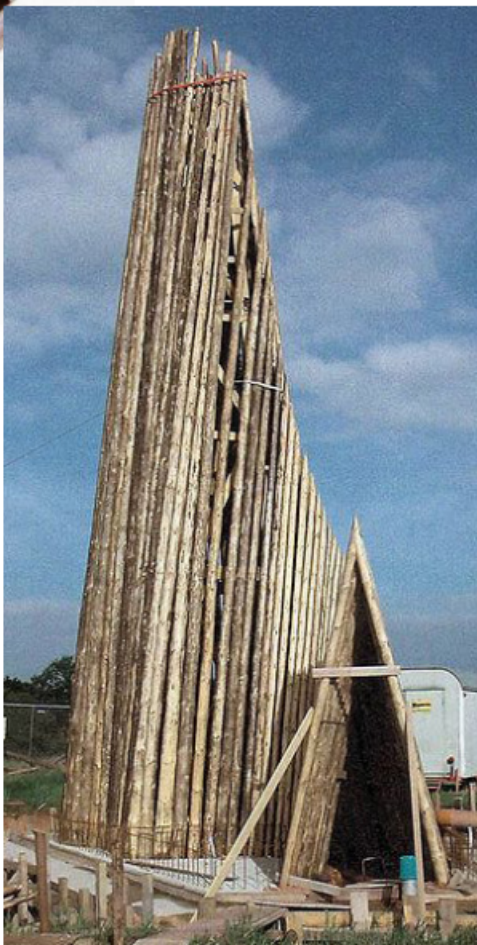

Bruder Klaus Field Chapel.
The process of vernacular construction to build rural spiritualism.

Image Source; Ludwig, Samuel, and Mayer, Thomas. 2005-2007. *Bruder Klaus Field Chapel*. Photograph. Mechernich, Germany: Archdaily. <http://www.archdaily.com/106352/bruder-klaus-field-chapel-peter-zumthor>



Bruder Klaus Field Chapel.
Building Section.

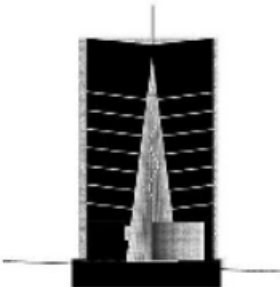

Bruder Klaus Field Chapel.
Building Section.



Bruder Klaus Field Chapel.
Molten Lead Figurine.

environment through sensualization of light and materiality. This reveals a deeper experience within the individual who experiences the sensory environment and productive landscape simultaneously, considerably enhanced by a deeply cultural association.

The exemplary work of the Bruder Klaus Field chapel demonstrates the ideal architectural design qualities that will orient the consumer experience - light and materiality. As discussed, the integration of the industrial hemp networks could provide an apt medium through which the architect develops the sustainable material culture and the development of resilient building forms. The main product of the hemp network proposal would be for the hemp shiv that can be mixed with hydraulic lime to create Hempcrete, a remarkably sustainable building material and the emphasis of a new vernacular farm building. Research into the Hempcrete building design reveals an economical integration of a hygrothermal masonry (hemp shiv and lime binder) with standard wood framing techniques.

Shiny Pebbles and Large Ripples

Having revealed the existing rural landscape and the potential for new networks of sustainable agricultural production, it becomes clear that the architect must uncover threads of design potential to test how realistic they may become. As a relatively new industry within Alberta, industrial hemp production could have a significant effect on generational farms as not only a highly lucrative, cereal/fibre crop, but as adding to the collective identity of the rural landscape. Local networks of hemp knowledge are essential to orienting the local hemp network and must be explored

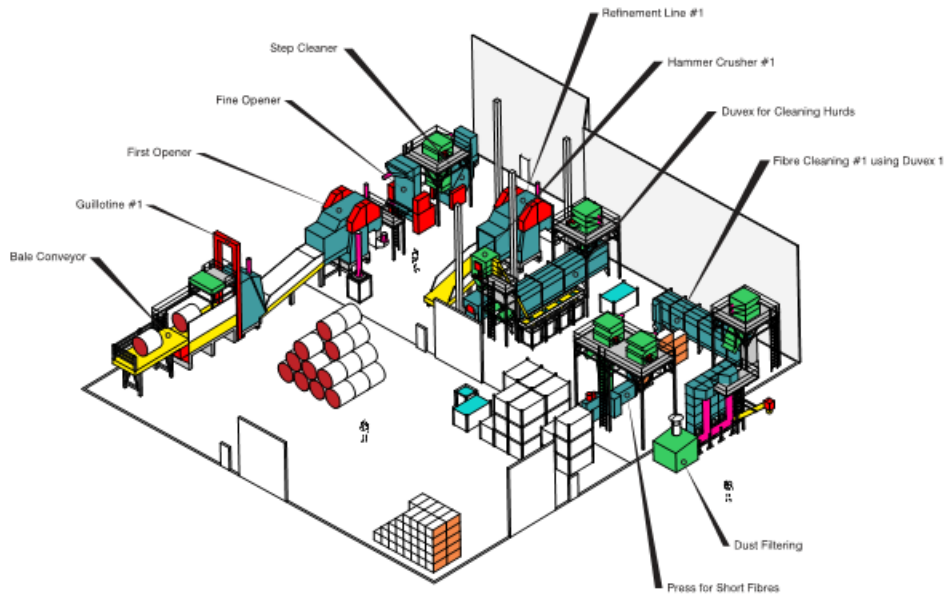

Decortication and Fiber Extraction Process Single Production Line

Processing Capacity : 1t/hour, requires 4 passes to achieve desired product
 Area : 1576 m²
 Van Dommele Engineering, Pilot Fiber Decortication Plant
 Alberta Innovates Technology Futures
 Vegreville, Alberta



Hempcrete
Insulating Block



Biofibre Panel
Wood Waste, Wheat Straw & Hemp Shiv
w/ Industrial Polymer



Hempcrete
Structural Insulating Block

Vegreville Pilot Decortication Plant.

Developing a program for the Hemp network Decortication Plant and identifying the potential of Albertan agriculture to produce biofibre construction products.

for their potential role in a re-imagined rural landscape.

Pilot Decortication Plant_Vegreville, Alberta

To gain insight into the struggles facing the widespread cultivation of hemp in Alberta, I visited the Alberta Agricultural Research centre of Vegreville, Alberta on December 17, 2015 to tour their pilot decortication plant. The pilot plant is maintained by Alberta Innovates Technology, a publicly funded company whose mandate is to assist Alberta's entrepreneurs develop small-scale industries through technology. Facilities such as this demonstrate the governments' intentions to develop Canadian production markets and are built specifically to educate producers and jumpstart regional manufacturing. The innovation of the decortication process is that it can process a variety of agriculturally produced, fibrous plants such as hemp, flax, and kenaf. As a pilot plant, the Vegreville facility is half scale of a commercial facility and can process 1-tonne of product per hour, but this process requires four passes of the same product to achieve the level of material refinement required by manufacturers; thusly this scale of operation is not efficient.

Conversely, a full scale decortication plant can process 7 tonnes of product/hour but requires dual processing lines, operating simultaneously, and would require an investment of roughly \$15 million for the equipment alone.⁸² This of course presents an obstacle to developing local hemp networks as local producers are unlikely to afford such facilities. Traditionally, farmers established co-operatives to organize the selling and

82. Byron James, personal interview, December 2015.

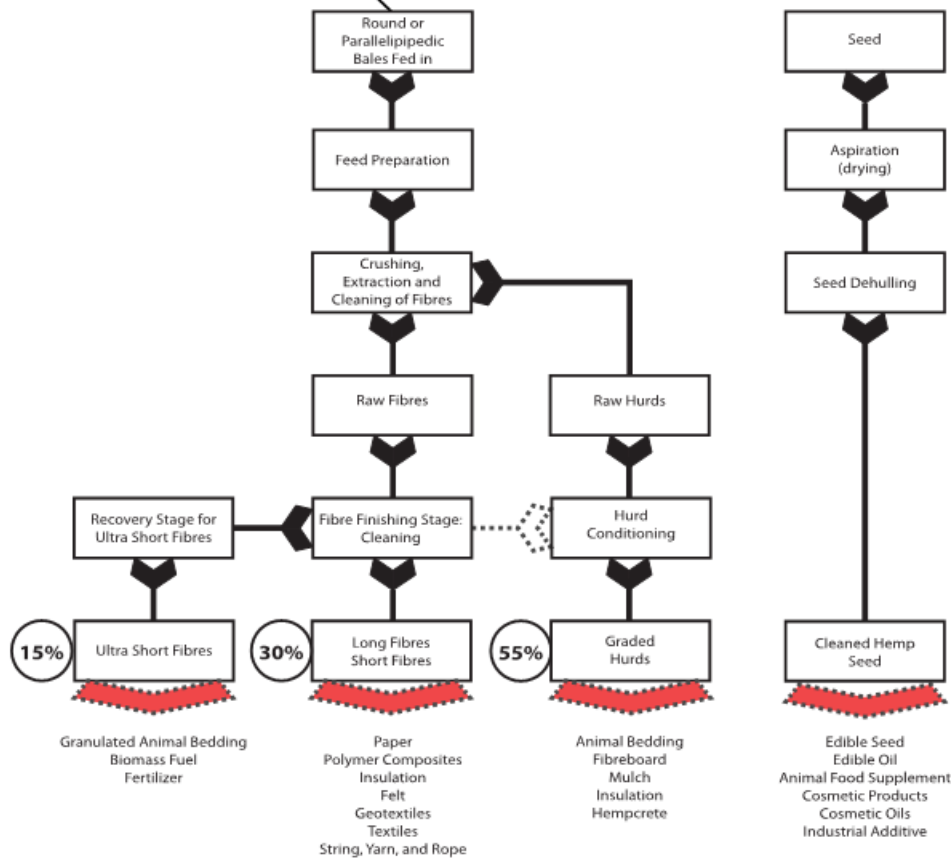
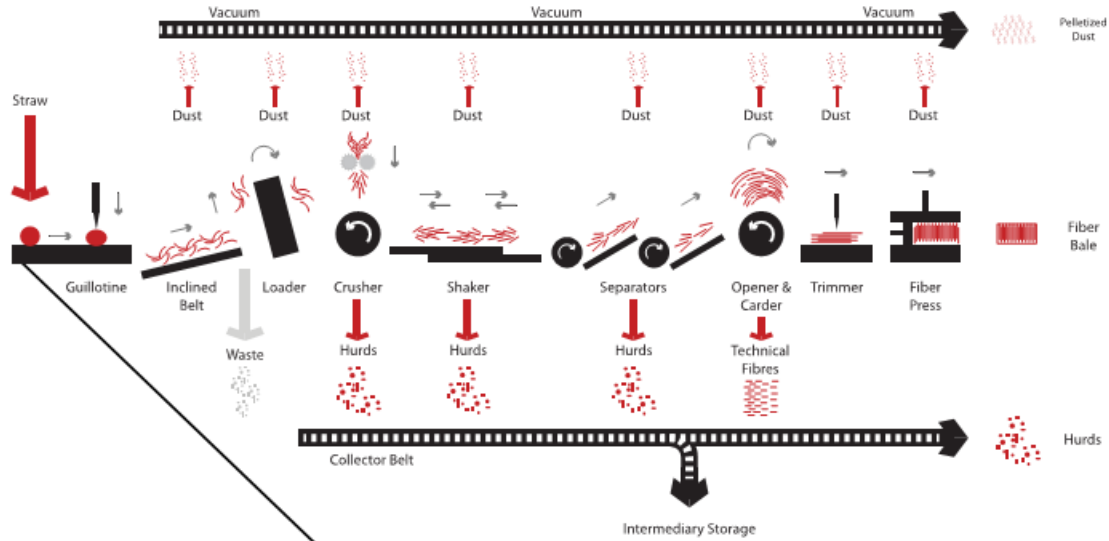

Diagrams of the Decortication Process and resultant by-products of the industrial hemp plant. As steady supplies of hemp feed the decortication process, local producers can develop their own value-add products from the fibers and shiv - enhancing the consumer experience of the rural landscape.

Diagram adapted from Image Source;

Stanwix, William, and Alex Sparrow. *The Hempcrete Book Designing and Building with Hemp-Lime*. Chicago: UIT Cambridge, 2014. Kindle edition.

transportation of agricultural produce to larger markets, an ideal symbolized in the prairie grain elevator. This model for community organization and market access can be re-implemented into the rural landscapes in the form of community material processing depots which give local producers and consumers' access to building mediums. These processing facilities are critical for incentivizing rural producers to integrate hemp cultivation into their process and to sustain the facilities demand for raw material, ie. the hemp bale. It was suggested that such a facility would need to offer hemp cultivators \$80-\$100/tonne of hemp straw to motivate local production networks.⁸³ It was suggested that special provision be made by the facility to provide specialty equipment or knowledge that assists in the cultivation and harvesting of the industrial hemp plant.

Given the basic parameters of what the hemp network requires, the architect begins to seek specialists who can validate a local industrial process. From conversation with the plant manager of the Vegreville decortication facility, I was directed to Tekle Technical Services Inc. (TTS) of Edmonton as being a leading innovator of the biofibre industry.

TTS Industries_Edmonton,Alberta

At TTS, we are committed to a sustainable future. Our research and product development teams are guided by the principles of the triple bottom line, which takes into account the social, environmental and economic factors that make a product truly sustainable. We focus on developing products that will have the lowest impact on the environment, the highest return on investment, and the greatest benefit to the communities where our plants are located."

- Tam Tekle, ⁸⁴

83. Ibid., December 2015.



Hemp Biofibre furniture by TTS Inc.



Hempcrete and Biofibre Building Materials.

Hemp and Biofibre products produced by Tekle Technical Services and manufactured at a pilot scale in Edmonton, Alberta. TTS Inc. is often approached by commercial outfits that seek a natural material aesthetic to visually promote sustainable business models and products. Tam Tekle has utilized personal relationships to help local producers develop sustainable building technologies for the agricultural process, as exemplified by a rural farmer's personal greenhouse. The vision of TTS Inc. is to provide full design and manufacturing services of biofibre technologies and products.

Image Source; Tekle, Tam, (President & CEO, TTS Inc.), correspondence with author, January 4, 2016.



Building a Hempcrete Greenhouse.
Built on organic farm operation 10 miles south of Vegreville, Alberta.

Initial research of the TTS website reveals a unique and local company that develops sustainable material products and process oriented at rural community development. Meeting with Tam Tekle in person, I was greeted by a very sincere man who devolved to me the earnestness of his work to build a sustainable building product industry for Alberta. It is obvious that Work can take on a significantly deeper meaning to the individual. From our conversation, Mr. Tekle confirmed that if a hemp network were proposed in Alberta, a decortication facility is required to catalyze the continued cultivation of raw hemp materials that would support local product markets. As material engineer, Mr. Tekles expertise is in the design of material production systems and the services of TTS would provide schematic design and fabrication of machinery for local entrepreneurs to develop biofibre products. When discussing what the programming of a decortication facility requires, Mr. Tekle proposed a commercial production line that would be designed and built in Edmonton for a third of the cost for European equipment - a line that can process 10 tonne of product/hour.⁸⁵ Following is the summation of our conversation and the basis from which the rural hemp network is validated.

Given the context of establishing a commercial hemp industry in rural Alberta, it is obvious that the scale of land systems, communities and local producers is limited by the economical transport distances of the harvested plant. The industrial hemp stalk has a low bulk density and is recommended that its economic limitation is between 50

84. Tam Tekle, personal interview, January 2016.

85. Ibid., January 2016.

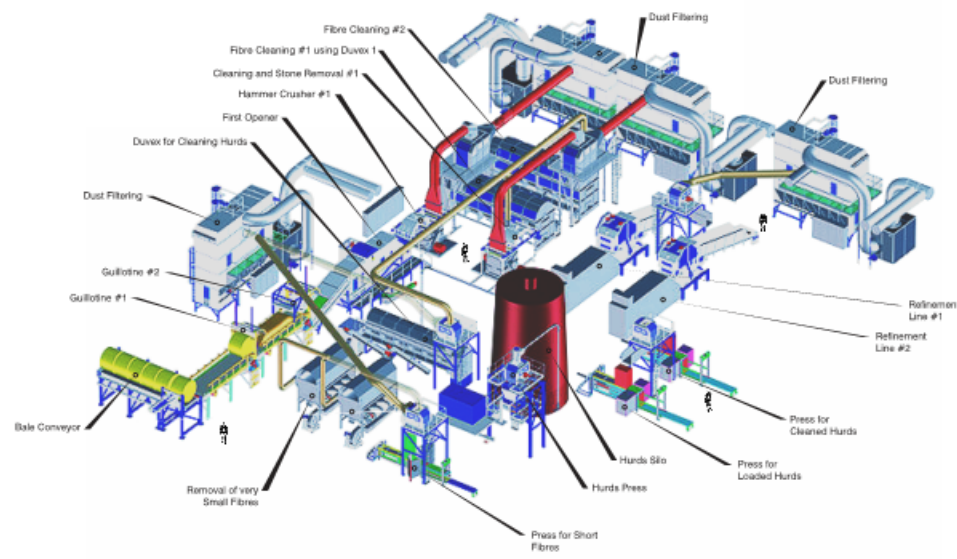

Decortication and Fiber Extraction Process_Double Production Line

Processing Capacity : 7-8t/hour, requires 1 pass to achieve desired product
 Area : 1576 m2
 Van Dommele Engineering, Model Commercial Decortication Plant

Image Source; Cretes. "Fibre Processing." Last modified June 20, 2016. http://www.cretes.be/en/category_50.aspx

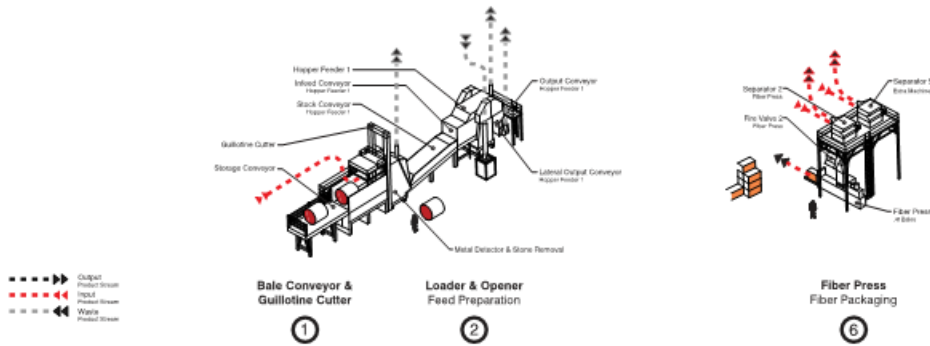

Decortication & Fiber Extraction Production Equipment



Commercial Decortication facility and Decortication Machinery.
 TTS Inc. would be responsible for designing the actual decortication equipment and process.
 Partnerships between industrial designers such as TTS and rural producer networks could establish the principle model for commercial hemp production. A great hinderance to establishing the Hemp network is a dependence on European equipment and seedstock.

miles to 100 miles and as such will integrate the productive communities of three counties in rural Alberta.⁸⁶ At the heart of this region will be a hemp and flax decortication facility (processing equipment and process are same) that can process 10 tonne biofibre/hour, and would require 53 producers each growing one quarter section (avg. 160 acres) of industrial hemp to sustain its annual processing capacity of 20,400 1-tonne bales. Realistically, the greatest challenge of building a decortication facility becomes the adequate provision of material storage space that maintains an interior environment for the raw material. The vast spatial requirements of a full commercial facility suggest that, economically, it is beyond the reach of the individual, and requires a ground-up design approach to ensure a community network to support the basic process of hemp production.⁸⁷

Community Resiliency

For it is in the nature of the human species -- all people, you see -- to be able to deal with environment, hence also to fashion the spaces they require, adequately -- and sometimes beautifully. The way people are also given to communicate with each other through language -- speech -- that other gift, which, like making spaces, still belongs to their primordial equipment.

-Aldo Van Eyck⁸⁸

To change a high-carbon community into a resilient, low-carbon community, it is evident that a greater cooperation is needed between the design professionals which shape the built environment. The architect controls built form from project to project, yet is regulated by a
86. Ibid., January 2016.

87. Ibid., last modified 2016.

88. Van Eyck, et. al., *Writings*, 534.

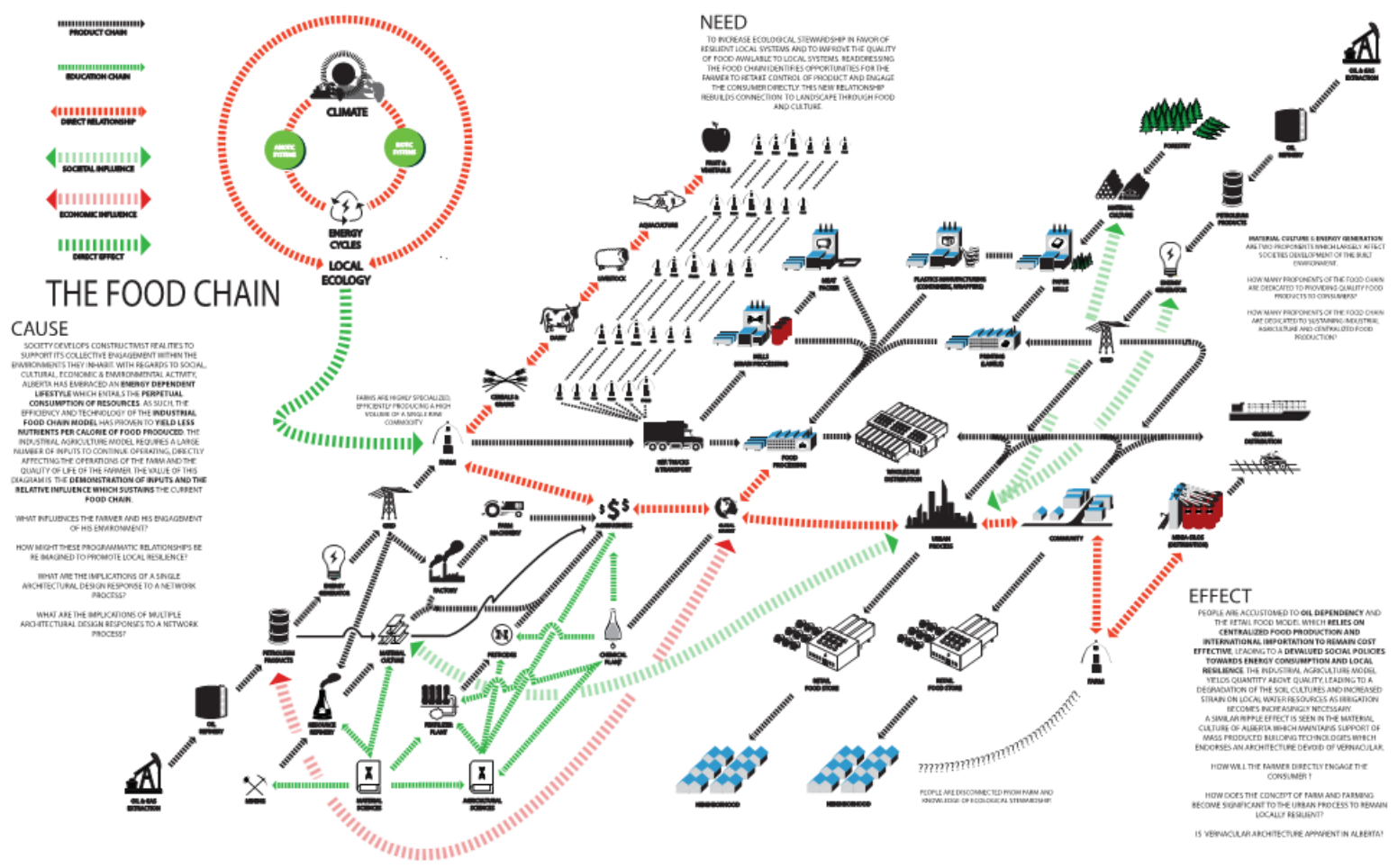

Diagramming the Industrial Agriculture Systems and the networks that dominate the generational family farm.

Diagram adapted from Image Source; Fluck, R., and Baird, C. Direlle. *Agricultural Energetics*. Westport, Conn.: AVI Pub. 1980.

greater framework of disciplinary knowledge and ordinance, so must reach beyond the limitations of site to affect change at greater scales. As such, the process of changing existing systems of production and consumption with sustainable alternatives will necessitate an organization of individuals and organizations highly skilled and invested in the resilient community model. The architect must reach out to the entrepreneur producer and community simultaneously so that new systems of production are wholly integrated into the rural landscape.

For a sustainable community model to be successful, multidisciplinary teams of designers will establish performance targets consistent with the communities goals and objectives. The team recommends actions, strategies, policies, programs, codes and ordinances, best practices and tools that best accomplish the goals and objectives, providing concise cost/benefit evaluations and performance expectations for each. This is an iterative process that requires constant engagement of the community.⁸⁹ The architects role is significant to this process as they facilitate the engagement and education of the public, and can utilize the entrepreneur producer as a direct link to community and environment. In this sense, the rationalization of a buildings design may be informed by the producers process within landscape, however, the building can simultaneously inspire the process of the individual within the community beyond. This is to say that the architect must invest within the architecture an intuitive educative process which collectively engages the public in the consideration of the greater goals and objectives for community resiliency.

89. Coyle, *Sustainable and Resilient Communities*, 25-26.

Planning Frameworks

To assist the uptake of the sustainable community model, the architect should develop a comprehensive design model that anticipates the roles of other design professions and the systems they regulate. As architecture is a single aspect of the rural landscape, it does not control greater systems that precede it, and thusly the architect must define the role of the architecture as the producer defines the role of the generational farm. By seeking planning frameworks that have been developed for a resilient communities, the architects role and the role of the architecture can be clearly defined within greater design frameworks.

Overall, the complexity of rural systems goes beyond the scope of the conventional architect, yet, the development of an architecture that can become multiple in the rural system would prove beneficial to a rural community. As well, if the community is resolved to become sustainable, then the community must begin to adapt from its high-carbon lifestyle to a lower-carbon lifestyle and will require incentive. Given that the process of licensing a productive landscape as organic has become a legal process and operational transformation, there remains a good reason why most farmers within the Warwick community do not operate organic farms. This reason being that a productive landscape must remain free of chemical inputs for a period of 10 years, and must omit the crop harvested from the perimeter of their fields that border any field using chemical inputs. In essence, the cost of industrial agriculture in todays landscape is a minimum period of 10 years of renewal to be considered restored.

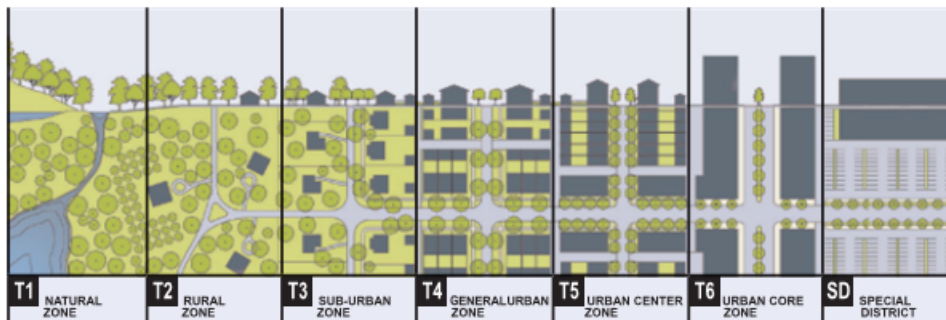
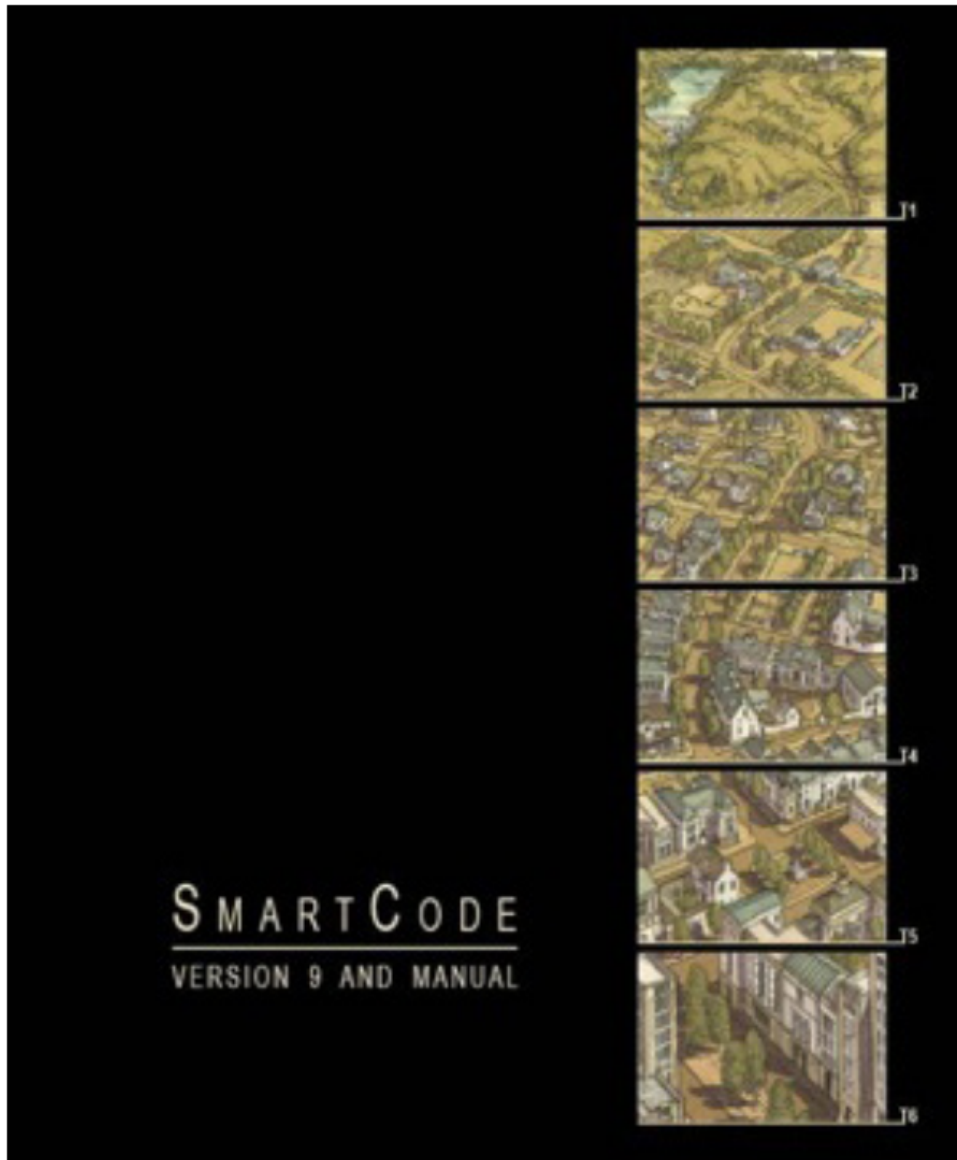

A TYPICAL RURAL-URBAN TRANSECT, WITH TRANSECT ZONES

Smartcode v.9.2.

Sustainable community planning frameworks speed the design of the resilient rural community and anticipate an urban assemblage.

Image Source; Center for Applied Transect Studies, *SmartCode Version 9.2.*, Last modified March 24, 2015. <http://transect.org/codes.html>

Given that industrial agriculture is inherently a high-carbon activity, consumers often translates this to a rural community that disassociates itself from the natural landscape. To re-obtain a shared identity as a community associated to landscape, the architect employs the Ecological Toolkit, a planning framework specifically developed for transforming high-carbon communities into resilient communities by mapping their potential systems for sustainable redevelopment.⁹⁰ This toolkit sets forth two design objectives for the architecture. First, ensure that future patterns of growth and regrowth are much more efficient, resource conserving, ecologically benign, and socio-economically vibrant. Second, develop an economy that reflects and reinforces the economic value of these efficiencies. In the case of Warwick and the rural landscape, the principles of the toolkit developed for one locale can be reapplied to sites of similar context and prospect across the globe; the notion of multiplicity. The use of planning frameworks sets forth quantifiable measures for design success and a sounding board for the design process against conventional design frameworks.

As the generational farmer must simultaneously function as producer and consumer, they are proficient in the concept of local economies. If resilient community models require sustainable models of economic production, than the architect can utilize the Sustainable Commercial Framework developed by Seth Harry and Associates Inc., to facilitate stronger connections between generational farms and their rural community. Sustainable commerce is described as a rational and sustainable framework for

90. Ibid., 25-58.

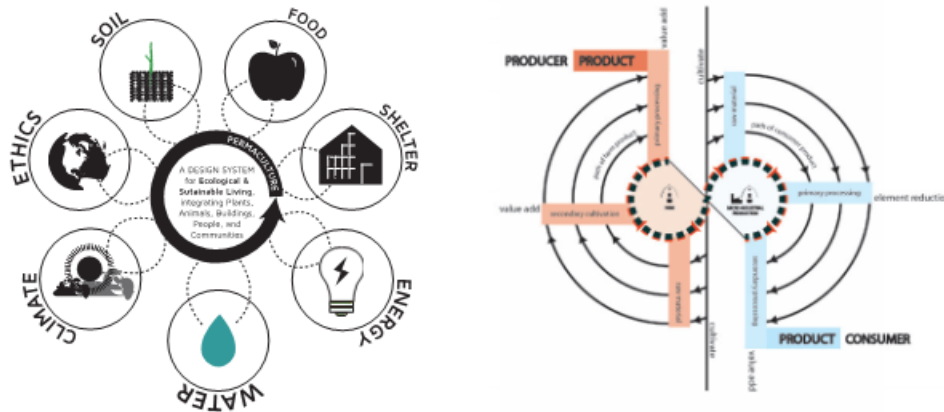

Permaculture Framework and the Product Sustainability Model. Permaculture outlines the basic principles for creating permanent agriculture. Sustainable materials must act dually as potential process inputs and outputs to ensure the greatest conservation of energy.

HEMP

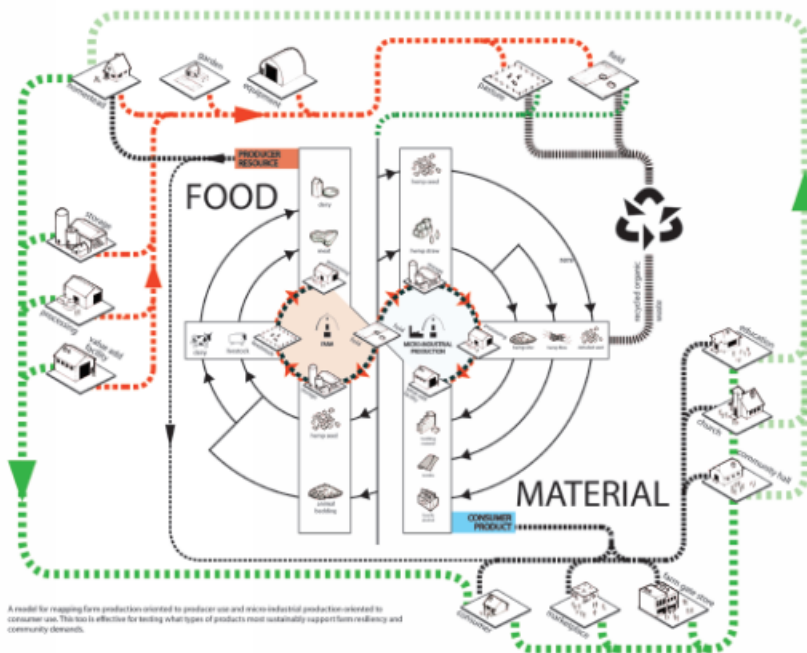

Product Sustainability Model. Modelling sustainability of hemp within rural systems of production. Economic and environmental value can be directly utilized by agricultural producers and is the basis for a sustainable agricultural process..

the local production and distribution of goods and services necessary for daily life. This framework is based on the principle that, “the externalization of human, environmental, or social costs associated with the production of basic goods or services should not be enabled or allowed, either directly or indirectly, as an unintended consequence of the way in which we plan or build our communities.”⁹¹ Through the sustainable commercial framework, the architect acquires two more design objectives. Firstly, support local goods production and small scale, independently owned retail and commercial enterprises. Secondly, help communities retain and reuse the highest percentage of their gross economic benefits related to commercial activity (multiplier effect), encouraging a robust regional economy, and reducing demand for long distance transportation of goods.

When comparing these two planning frameworks, correlations can be drawn between the objectives of a sustainable rural community and the opportunities of a commercial hemp network. Foremost, the creation of primary biofibre processing facilities will add value to the generational farms primary efforts as agricultural producer. Secondly, the development of a rural material depot where farmers can easily access an economical and sustainable building mediums would propagate a vernacular building culture and resilient commercial model. As industrial hemp can be readily processed into products consumers demand, the implication of a primary processing facility within the rural landscape would allow generational family farms to develop value-add products direct to consumer markets. What this means to the architecture is that one medium can

91. Ibid., 86-89.



The rural producer can utilize renewable energies such as PV and Geothermal to offset the energy requirements of the agricultural lifestyle.

proliferate a number of unique processes, landscapes and socio-technical forms, enacted through multiplicity.

Schematic Sustainability

A challenge that faces the global effort for energy conservation is the variance between each nation's value and demand for energy. By extension, the consumers of each specific region stand as proprietors of an energy consuming society. As these consumers demand access to energy alternatives, they support political policies and energy efficient technologies as a representation of their individual beliefs. However, without established networks to support a sustainable lifestyle, consumer's efforts to reduce their impact on the environment may not manifest without exceptional circumstance. It is critical that models for sustainability be developed in cooperation with the individuals efforts to ease the transition process, but must be derived from the consumers need. As well, it is critical that regional standards be established for greater consensus of climate change policy. The reality of our socio-technical world is that our methods for implementing and measuring energy conservation are culturally specific; complicating any correlations that can be drawn between global conservation strategies. It is then essential that designers begin to simplify the consumers understanding of the energy cycles through tangible experiences.

Richard Kroeker describes his work as "focusing on usability and ecological sustainability ... [e]ach building pays special attention to its surroundings so as to retain the natural beauty of its location".⁹² Kroeker's work with

92. Richard Kroeker Design, "Home", 2010.

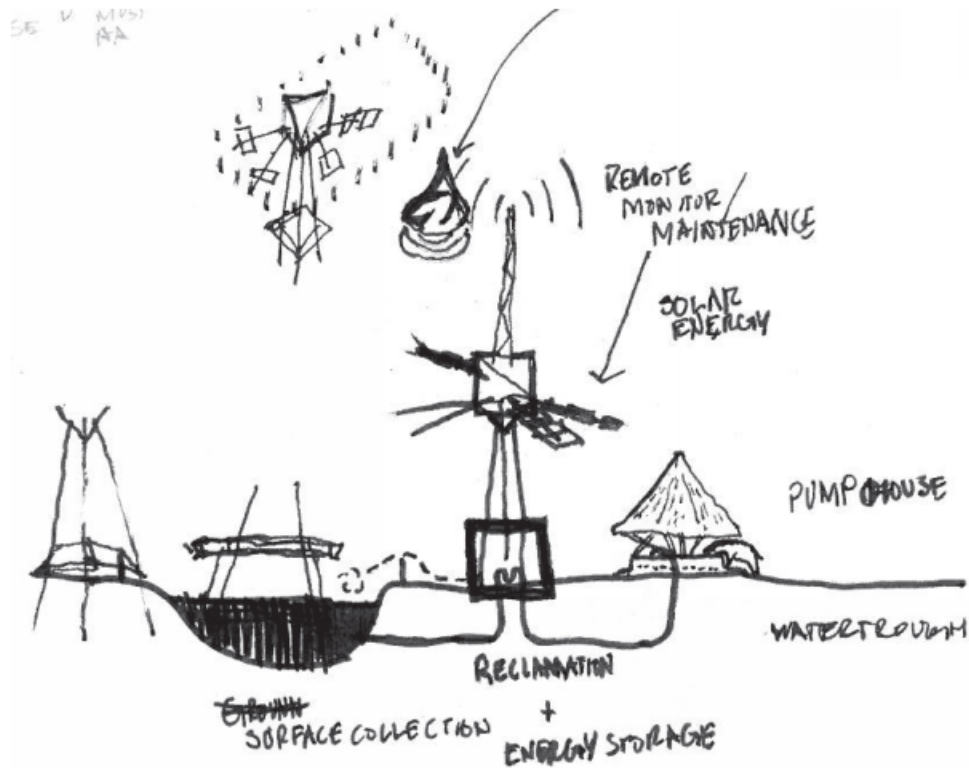

RE-Tower and the Rural Dugout.

Designing systems for integration and remediation. Renewable energy systems such as Photovoltaic and Geothermal can allow rural producers to disconnect from the grid to create production nodes within the rural landscape..

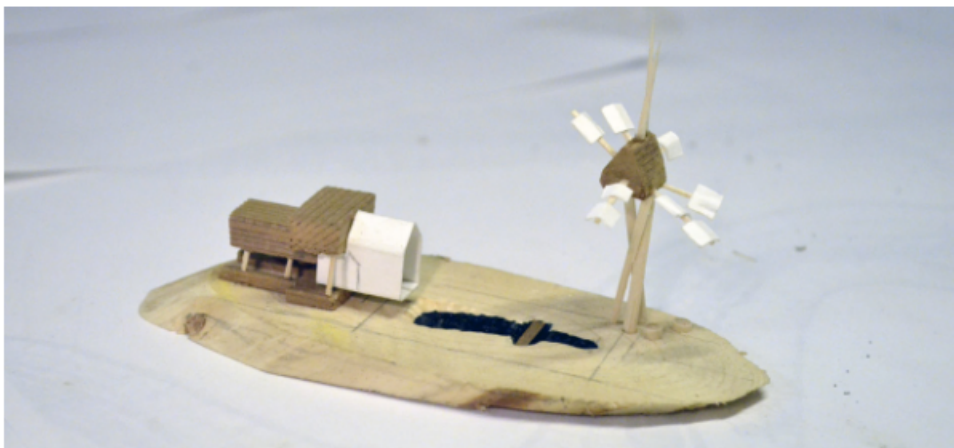

RE-Tower and the Studio Residence

Designing systems for integration and remediation.

the Pictou Landing Health Centre demonstrates how designers can synthesize a traditional material knowledge with conventional building practice and materials to create comfortable interior environments.⁹³ In creating a construction material process that utilizes the producers craft and complements the consumers notion of homecoming, building systems begin to integrate with sustainability principles. Working from traditional building processes that are independent of conventional energy sources, designers can begin to develop a low energy building typology that effectively teaches consumers about sustainable building practice.

It is important for designers to develop synonymous design tools which can aggressively model building energy, yet are within the consumers' realm of understanding. 'Matchboxenergy.com' is one such energy modelling tool crafted by Richard Kroeker, delivered through an intuitive interface which guides users through the various measurements for calculating energy demand.⁹⁴ This set of calculations is derived from the professional architectural discourse and is a progressive step in formulating consumer behaviour due to its accessibility and tangible relationship to consumer habit. As architects synthesize our collective knowledge and building practice in relation to the world, they stand as an integral step to shaping our material culture. This pursuit of a collective practice has solidified such practices of a national building standard, and such schools as the German Passivhaus Institut. These movements signify the professions acknowledgement for a more symbiotic

93. Kroeker, "Building Systems", 2015.

94. Matchbox Energy, "Matchbox Energy Calculator", 2016.



1:20 Framing Model of Greenhouse/Kitchen

The greatest attribute of Albertas prairie sky is a crisp sunlight which reveals acres of gold in the rural landscape. Certain programming will be distinctly regulated by the availability or absence of natural light and the programming responds to natural cycles.

relationship between energy and lifestyle, and are driven by the social, cultural, economic and environmental events which formalize our socio-technical development.

When discussing how architecture will disseminate new building knowledge to the generational family farm, the architect looks to more energy efficient Live/Work/Play modes of living. Given that sustainability comes in many forms, the architecture can utilize the superior mechanical attributes of the Hempcrete wall system as the symbiotic medium for developing the rural landscape and consumer experience. What Hempcrete offers to the rural producer is a vapour permeable wall system that is super-insulative, fireproof, rot-resistant, pest-resistant, and self-repairing. A natural cycle of Hempcrete is the petrification of the hemp shiv into limestone and results in an architecture that enacts resilient built forms; becoming permanent within the landscape. Furthermore, Hempcrete is revealed to be an ideal building material for Low Energy and Passivhaus design principles.

Low Energy & Passivhaus Design

Passivhaus design is simply defined as a typology of low energy building, but was developed as a direct response to drastically reducing energy consumption. Developed by the German Passivhaus Institut for the past twenty years, the Passivhaus standard provides a universally applicable set of requirements for energy efficiency, its own certification scheme, requires a higher standard of energy efficiency than other standards, and must meet a standard of indoor air quality, energy demand and general level of quality.⁹⁵ The principles for sustainable design implemented in the



Straw thatch traditionally sheltered the rural resident. This sustainable building envelope grows from the rural landscape.



Plastered interior walls provide an intimate texture of the rural landscape.



Main Floor Plan

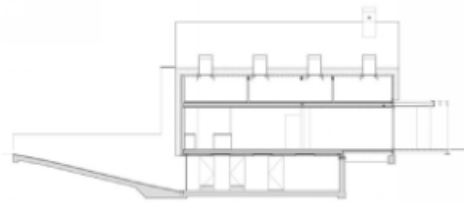

Building Section



2nd Floor Plan

Architect: Arjen Reas

Location: Zoetermeer, The Netherlands

Area: 744 sqm

Built 2010, *Living on the Edge* was developed for an urban entrepreneur that wanted a home on the edge of the city - between the urban and rural. From the architect; "Contemporary rural living was chosen as a project to mix the two in pure form. When working with pure forms it's also important to look at simplicity, durability and expression."

Image Source; Hageman, Kees. 2010. *Living on the Edge*. Photograph. Zoetermeer: Archdaily. <http://www.archdaily.com/82455/living-on-the-edge-arjen-reas>



Living on the Edge.
Subgrade garage
entrance and straw
thatch exterior finish.



Living on the Edge.
Exterior to interior and
the open program.

Passivhaus system are generous to the consumer utilizing conservation principles; providing reduced environmental impact, a model for building energy consumption that consumers can monitor and the economic savings from renewable energies.

The primary requirement of Passivhaus is to provide for the thermal space conditioning of a building, and sets a standard of 15 kWh/m² per year, or a maximum heat power of 10 W/m².⁹⁶ To contend with the various regional climates and the consumers' energy response, the second requirement of Passivhaus deals with building envelope and mitigating energy waste. This lies in the realm of the architect and designer, and presents an opportunity for agricultural landscapes to produce locally sourced, natural building materials. The third requirement of Passivhaus contends with issues of primary energy required to operate building systems and occupant services. A maximum yearly weighted primary energy usage of 120 kWh/m² per year is specified by Passivhaus and accounts for the energy losses in the transportation and transformation of energy to the building.⁹⁷

Currently, there are several key concepts which administer the Passivhaus standard, yet require clarification between nations, and should be the focus of designers; evaluation of thermal space conditioning demand, delivered energy, primary energy and weighting of sources, air
95. Dequaire, *Passivhaus as a Low-Energy Building Standard*, 378.

96. Ibid., 379.

97. Ibid., 380.

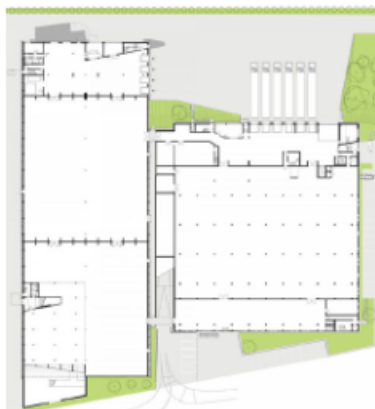

Main Floor Plan



2nd Floor Plan

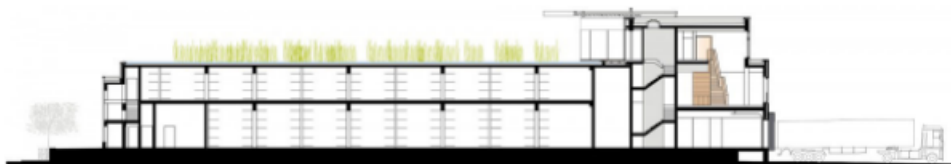

Building Section

Architect: Bolles + Wilson

Location: Münster, Germany

Area: 9158 sqm

Built 2009, RS+Yellow Distribution Centre is a configuration of 2 big-box store buildings. Meeting rooms and executive offices overlook a 45 x 65m reflecting pool - an innovative fire suppression system. The industrial building provides alternative planes of dwelling and inhabitation within the landscape.

Image Source; Erbring, Guido, Hauschild, Markus, and Richters, Christian. 2009. *R+S Yellow Distribution*. Photographs. Munster, Germany: Bolles+Wilson. <http://bolles-wilson.com/>

tightness, measured point: on site versus off-site energy supply, embodied energy, CO₂: a diversion from accounting kilowatt-hours.⁹⁸ These concepts relate directly to the energy consumption of the built environment and can be utilized as the conservation principles that designers seek to teach to consumers.

The practical application of Passivhaus design is the utilization of the site and its micro climate to affect a buildings energy usage. Principles for passive solar design and natural ventilation have been cultured amongst societies living in climatic extremes of hot and cold, requiring a finely tuned building response. Following the rapid development of a petroleum based society, energy and materials could accommodate any climate, leading to generations of consumers who believe they have conquered the environment. As technology and material science continue to advance the consumers draw of energy through the veil of energy efficiency, it is realized that buildings should return to the passive energy designs of local material cultures.

Passive design utilizes solar gains to account for three elementary energy components of passive design for buildings, which are heating, day lighting and natural ventilation.⁹⁹ These components amount to the thermal space conditions of the Passivhaus standard and are manipulated through the designers understanding of "site, [building] placement, building size and orientation (Area/Volume Ratio), geometry, building components and

98. Ibid., 380-84.

99. Jevremovic, et. al., *Passive Design Applications - Industrial Architecture Perspective*, 174.

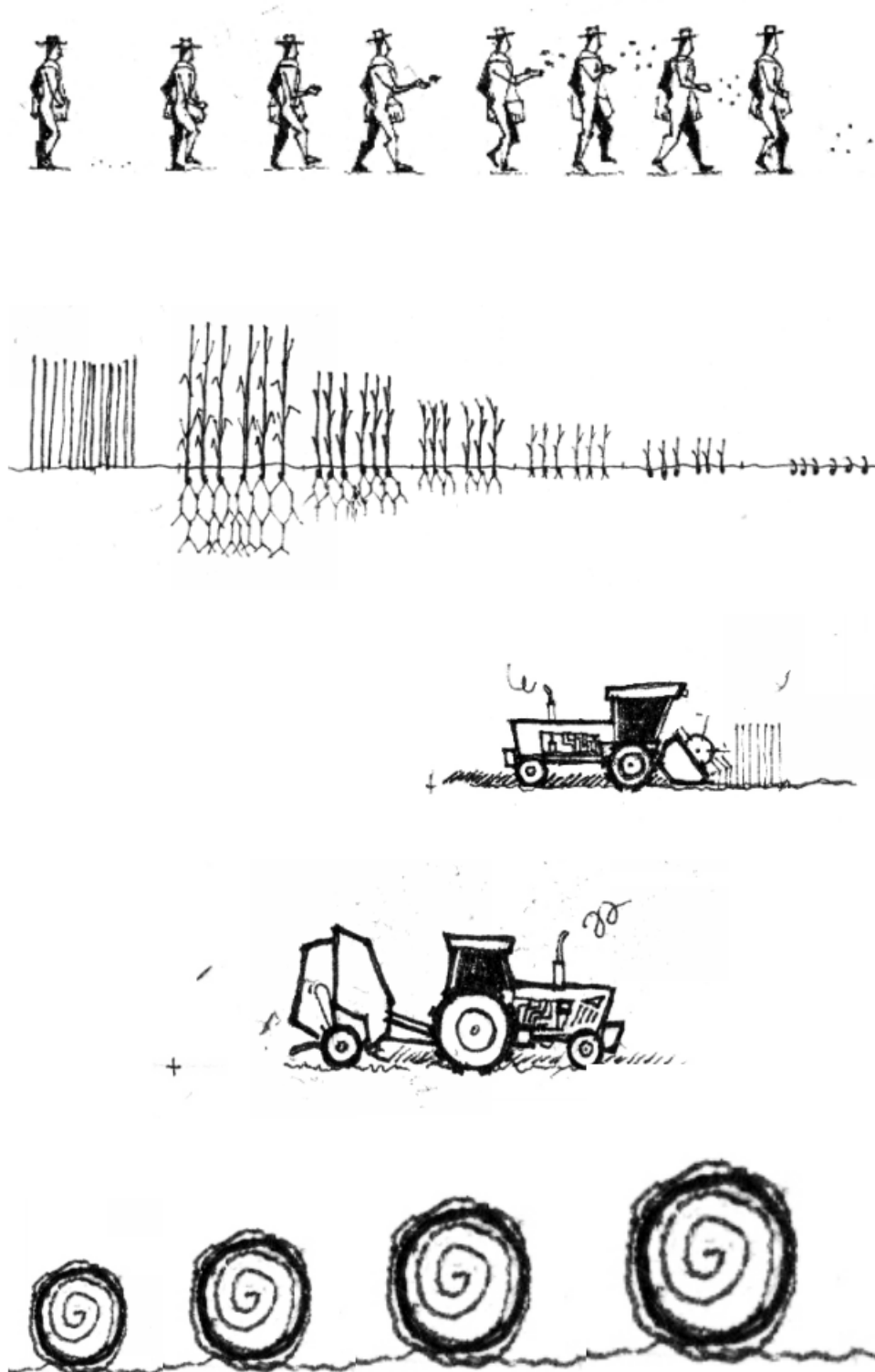

Manual vs Mechanized Labour and the Economy of Scale.

The validity of the sustainable process is the use of renewable energy.

The validity of industrial agriculture process is the consumption of non-renewable energy to produce beyond natural ability.

materials, window arrangement and building structure.¹⁰⁰

If designers understand the environmental systems which ultimately define the indoor air quality, their technical knowledge of building construction and material science can lead to a buildings independence of heating energy. Foremost, the analysis of four industrial production facilities from Chile and Germany demonstrate there are very different approaches in passive housing design and industrial buildings with regards to the size and occupancy of buildings.¹⁰¹ However, the common themes for energy conservation are applicable to both, and findings from the study demonstrates the need for a compact, rational and regular form which affects the ability of solar gains to penetrate the building effectively. In areas of extreme climatic variation, building envelope becomes paramount and the manipulation of material resources and production cycles may contribute to the adoption of low energy buildings as a societal norm.

Energy Economics

In a fashion similar to the centralization of food production industries, energy production systems have become highly dependent on expensive capital investment into specialized sites for fossil fuel extraction. The very identity of Alberta has transformed from agriculture to energy as the foremost comment from non-Albertan's is always about the Fort McMurray oilsands. But how can one offer such criticism of a place and process without acknowledging the lifestyles

100. Ibid., 174.

101. Ibid., 174.

that are reward for such environmental consequence?

Social and cultural networks reflect the consumers Live cycle and the products they purchase are learned behaviours of energy and food consumption - behaviours initiated by the customary associations inherited from family, friends, and community. In North America, the automobile is one consumer product which inherently links many aspects of the average consumers' lifestyle, such as travelling between recreation, work, and home and becomes an everyday tool. The consumers' dependence on the automobile and the necessary fossil fuels which reflects their social and cultural acceptance of the petroleum production cycle and the inherent consequence of its continued use.

To support the Live cycle, the Work cycle is inherently the cost analysis of the Live cycle, and the consumers preferred method of skill, craft or knowledge based production - intended to balance the demand of the Live cycle. Therefore, the consumer must actively participate in the economic and environmental networks of their region, in order to sustain the lifestyle they desire - this is the aspiration of the consumer to participate in social and cultural networks. If existing social and cultural networks provide criticism of the current energy models, than they must begin to participate in alternative models that support their argument. We do not have to abandon the automobile, but we can learn to drive less and more efficiently, a process only inhibited by a lack of existing infrastructure from which to base this learning process.

The reality is people have compressed so much activity into a charged lifestyle of 'consume and continue'

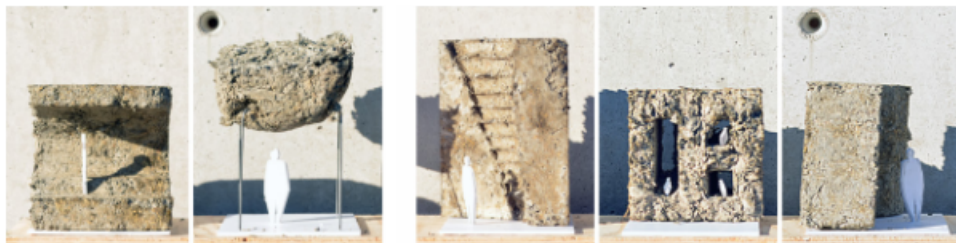
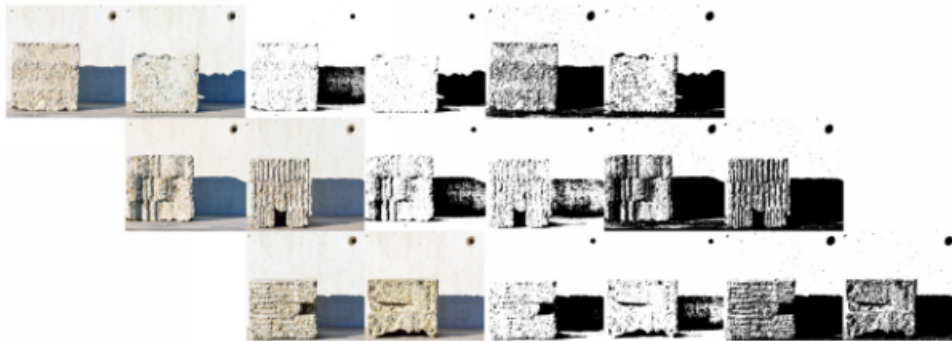
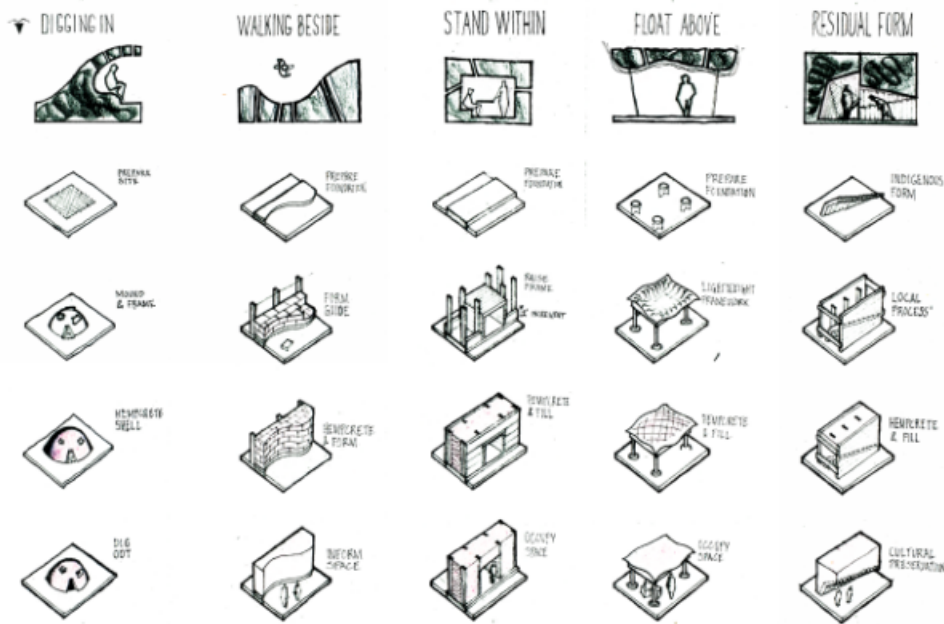

Dwelling with Hempcrete.

Modes of building and inhabiting the Hempcrete form. The texture of hempcrete affords the design an economy of scale, as the hemp shiv, the part, conglomerates with a hydraulic lime cement, the whole. The Hempcrete structure ultimately is mass within space and resilient to natural process.



Material Phenomenon -
Mass - Space

within the convenience of the default choice. This consumption tabulates from not only the embodied energy and environmental cost needed to realize the product, but extends to social and cultural values that are affected by prolonged use or dependence on a product. Most commonly, this is observed in the continued use of fossil fuels and their consequential industrial processes for extraction, processing, and consumption - contributing to increasingly louder shouts of rising green house gas (GHG) emissions and global climate change.

In this way, the consumers' residence is privately owned and the bastion for the basic activities that sustain us - a recharge station - and requires the greatest attention to indoor comfort and quality. The work place is the charged polarity of the residence, where producers efforts are best utilized and most profitable, and requires very different energy requirements from the residence. Representing the two extremes of the Live/Work cycle, home and office stand as two building typologies which architects can design for low energy and as vehicles for consumer education of a sustainable material culture.



Material Phenomenon -
Rest - Motion

By attaching the principles of sustainability and energy conservation to the consumers' experience of a everyday object like the residence, the lessons of process are reinforced and rehearsed. What is required is a model for the producer to communicate with the digital generation; to be competent in developing a consumers' experience which disseminates the cultural practice of renewable energies, sustainable production systems and community resiliency. As such, the language is the medium through which initial

Residual Form Process with Hempcrete Material.

Exploring the Bruder Klaus method of construction and residual form through molding of natural forms with constructed forms. Monumental mass creates a natural heatsink for solar energy - the nature of the hempcrete wall is energy conservation.

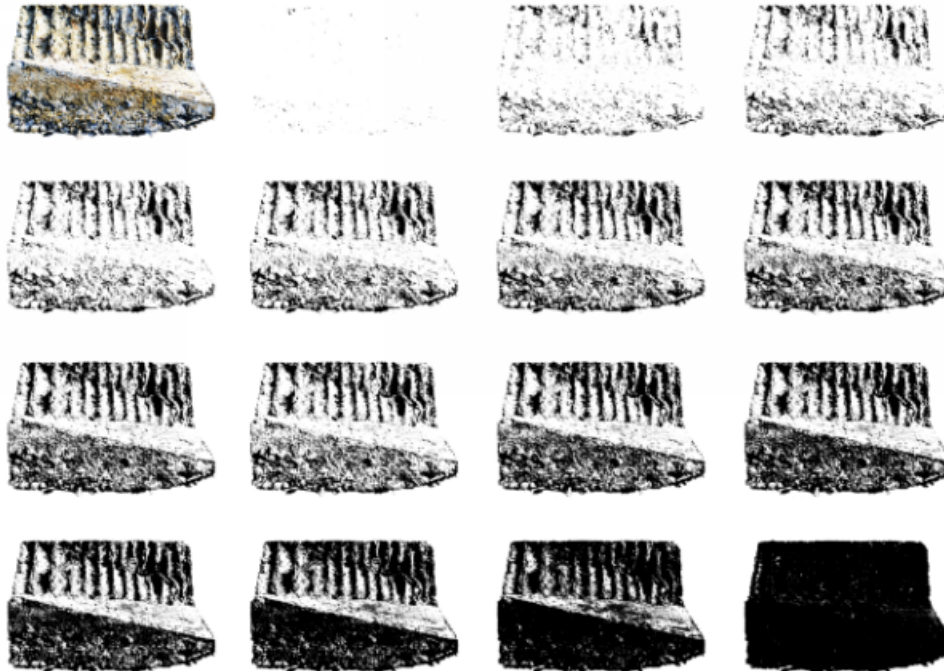

Grid Tied Photovoltaics with Energy Storage.

A large part of teaching producers and consumers about energy conservation will require constant accessibility to energy monitoring software.

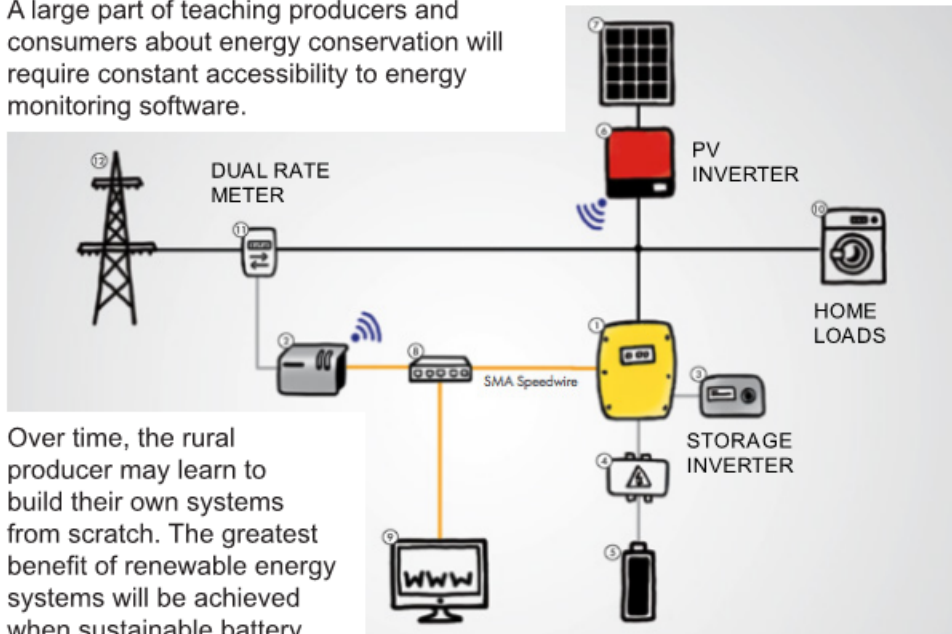

Over time, the rural producer may learn to build their own systems from scratch. The greatest benefit of renewable energy systems will be achieved when sustainable battery packs can provide greater economic returns.

Image Source; Swingler, Andy. 2015. *Grid Tied PV Systems with Storage*. "Trends in Solar Photovoltaic and Energy Storage Technologies," Lecture presented at Dalhousie University, Halifax, Nova Scotia, September 29, 2015.



Material Phenomenon -
Large - Small

dialogue stems and is best offered in person.

Renewable Energy Potential and the Cyber Farmer

The 20th century saw the rise of the industrial farm through the intensification of a mechanized agricultural process. As small farms struggle to compete for fuel and crop inputs, the entrepreneur farmer seeks technological alternatives to remain operationally competitive with corporate farms. What has resulted through a century of intensive Agri-business R&D is a technically informed producer; who must communicate the languages of botanist, engineer, and industrial designer to competently navigate the industrial agricultural process. As digital technologies become increasingly available to the generational farmer, they are systematically incorporated into the local process. Because of the generational farmers eagerness to develop a proficient agricultural process, the architecture should incorporate renewable energy systems into the rural landscape.



Material Phenomenon -
Hard - Soft

At this stage, the generational family farm begins to accommodate the designers need for a locally sourced, sustainable building material that can meet the economic, environmental, social and cultural needs of a resilient community model. As such, the industrial hemp plant presents a large opportunity for farmers to validate their role in our material culture through the provision of food, pharmaceutical, textile and construction products which can sustain local social and cultural systems, whilst benefiting the economic and environmental pursuit of the producer.

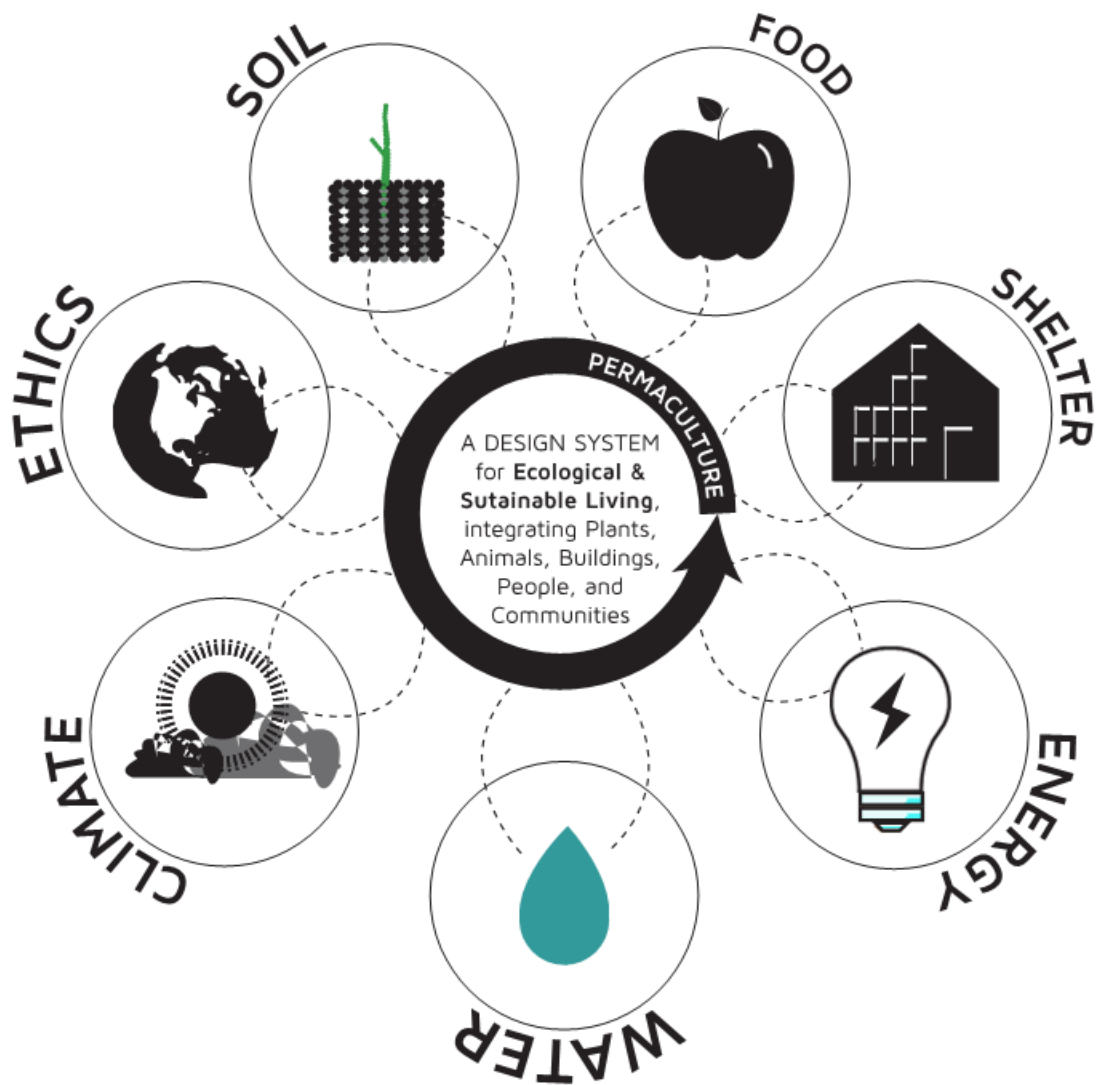
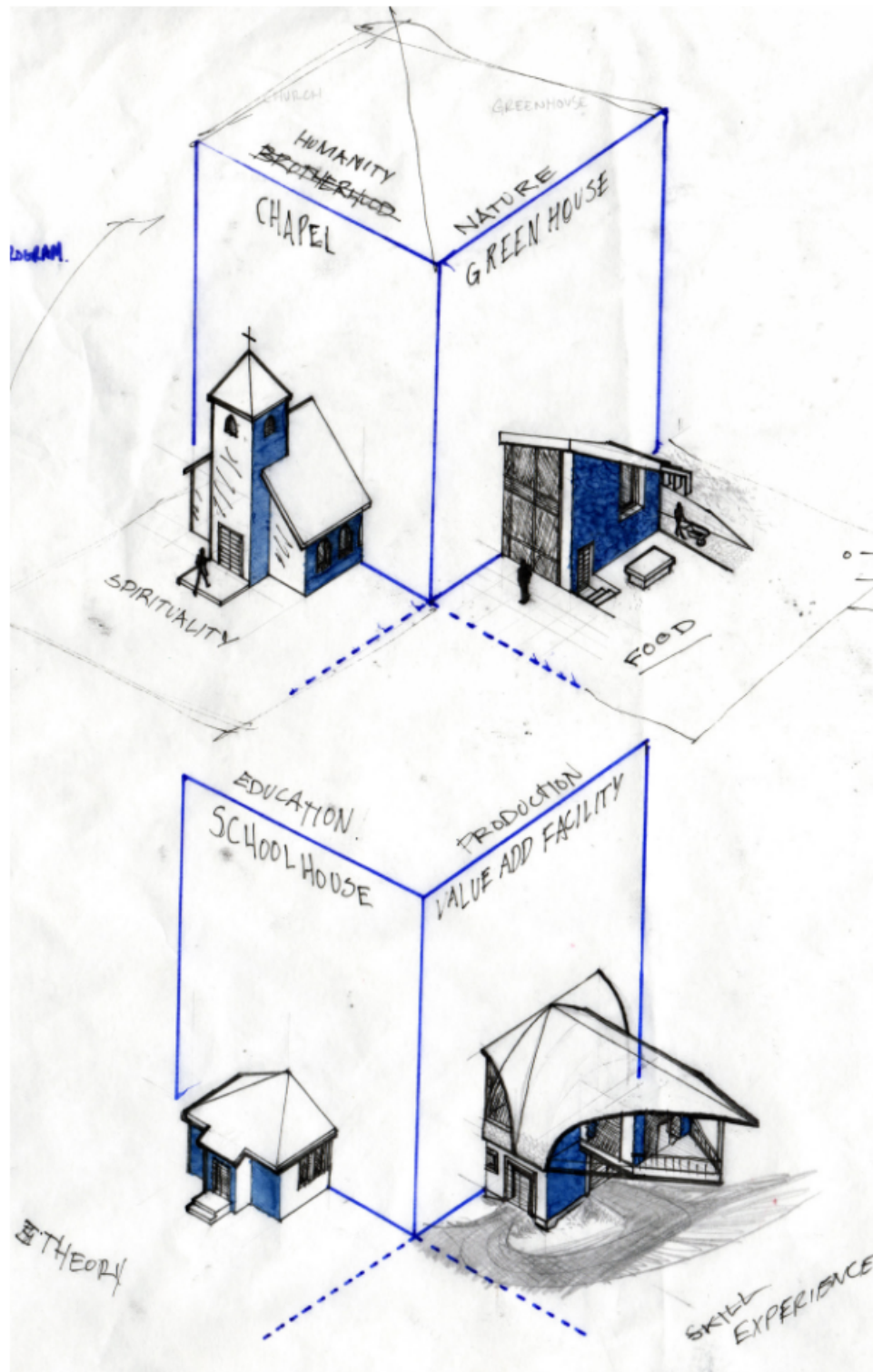

Diagram adapted from Image Source; Bane, Peter, and Holmgren, David, eds. *The Permaculture Handbook*. Gabriola, BC: New Society Publishers, 2012. Kindle edition.

Appendix B: The Barn I'd Raise

The result of an industrialized rural landscape is the recession of rural lifestyle. Intimate connections between the environment and the producer's agricultural process dictate the permanence of the generational family farm; a presence that when absent allows for the exploitation of social, cultural, and economic values. In place of quantitative mindsets, the resilient community intends to cultivate a qualitative understanding of human and non-human cycles for production and consumption. If farms build communities developed through the principles of Permaculture and low energy building principles, then consumers and producers alike will develop multiple reasons for investing in sustainability. To design for this level of permanence will require the entrenchment of cultural principles reinforced through the co-generation of architectural built form and building programme.



Reimagining the Vernacular Rural Community.

New systems stem from old as rural lifestyles update to reflect modern convenience. In the case of rural communities, stereotypical typologies are reinterpreted to meet the needs of a sustainable rural community and a resilient agricultural process. As social and cultural buildings are significant to the development of generational family farms, they too require reimagining towards the growth of the individual.

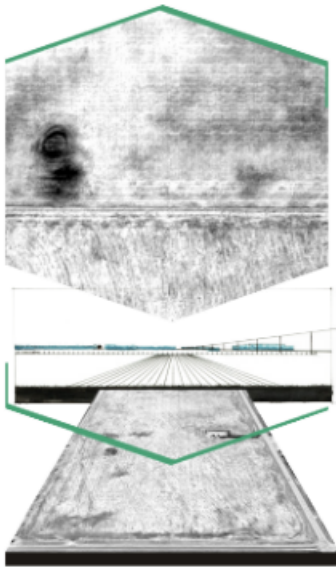

Study Site 1 and the Rural Landscape Vista.

What generational family farms represent to rural communities is neighborhood. Although farm sites exist with great amounts of space between them, consensus of process and landscape generates community value and resiliency.

Section 1: Rural Reclamation

Understanding the relationships that exist within the rural landscape will require the disentanglement of existing environmental, social, economic, and cultural threads which create the rural fabric. As such, acknowledgement of the direct inputs and outputs of rural systems will reveal implicit architectural interventions that can remediate a productive landscape. Debilitated by an industrial agricultural process that has annually impregnated the landscape with petrochemical fertilizers, biological deterrents and unnatural genetic modification of plant genealogy, the prairies have become a dramatically altered foodscape. The greatest smoke plume is recognized as the exponential application of pesticide and herbicide - considered the contemporary aid to rapid urban growth. What rural landscapes cannot afford is to become fully industrial and begs for a community response to re-attain some semblance of rural resiliency.

A clear intention of the architectural process is to realign and pool the wealth of knowledge that already exists within a rural community, attempting to expose the intimacy of the rural fabric to urban consumer experience. This leads architectural design to objectively adapt established building typologies into modern assemblages that seek to create multiple meanings for producer and consumer alike. As such, to create a unique consumer experience for the individual is not necessitated by the agricultural process, the producer, or product alone, but, requires a procession through inhabited landscape which ultimately defines all three in concert.

In the case of Warwick, Alberta, the community is not

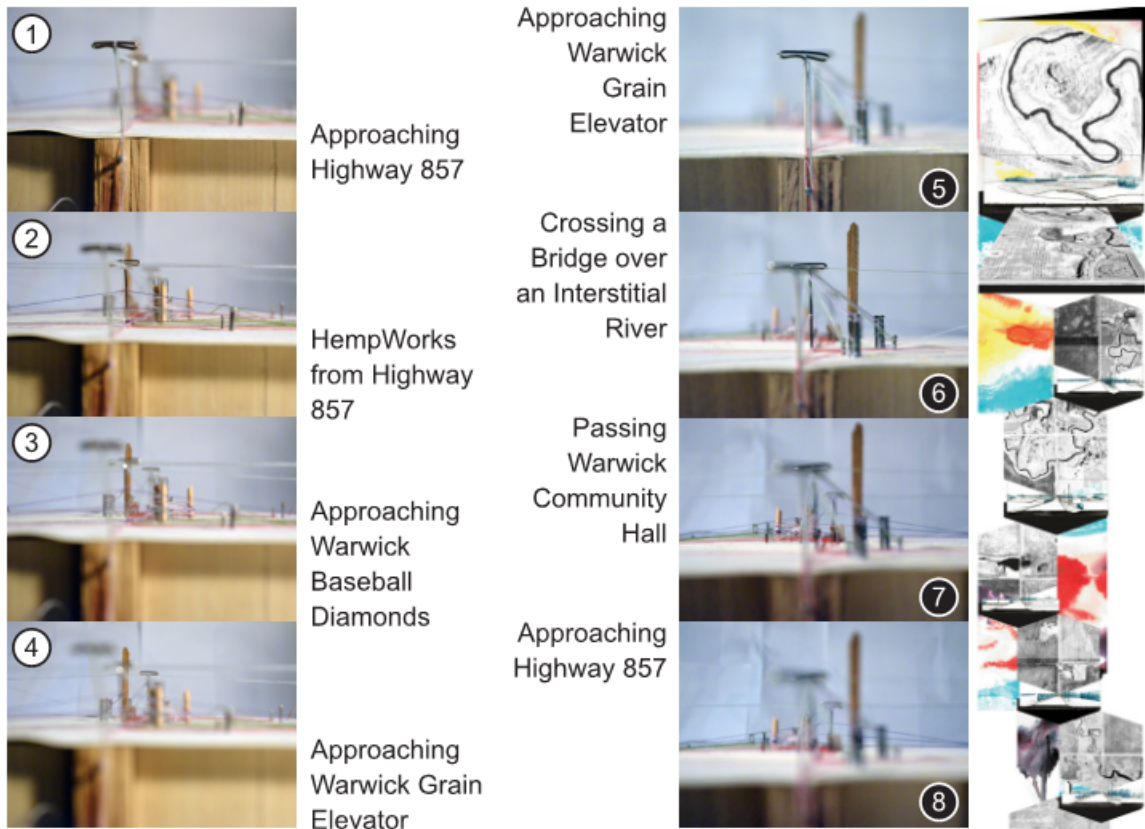

Travelling East on Warwick RD.

Travelling West on Warwick RD.

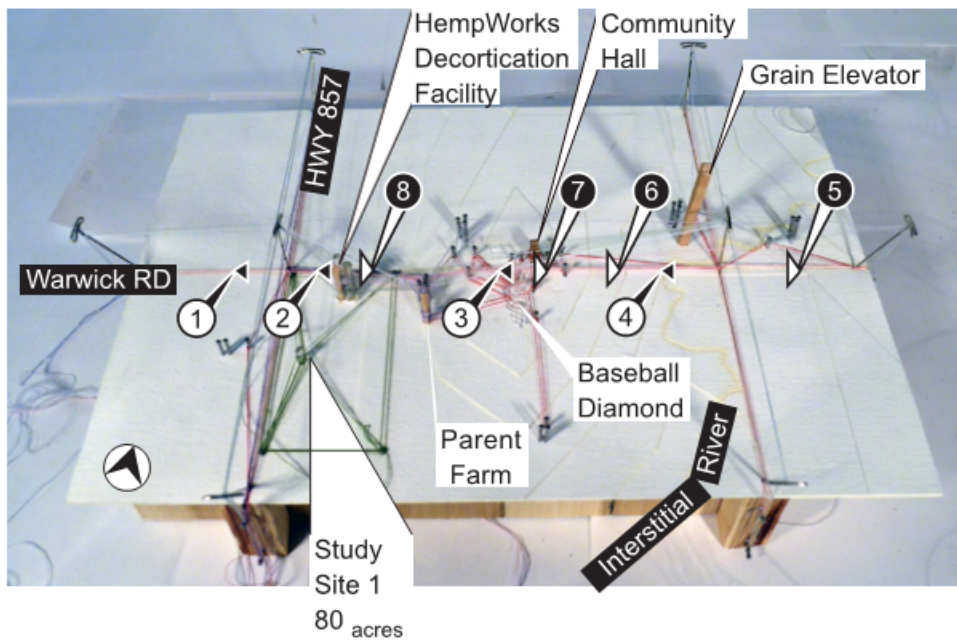

Procession through Warwick community model and the moments of the Hemp network. Concentrated development of a built environment can be defined as rural density. To begin the consumer procession, consumers are confronted by Study Site 1 which features a new generational farm model and the decortication facility. Study Site 1 becomes the gateway to a resilient Warwick community.



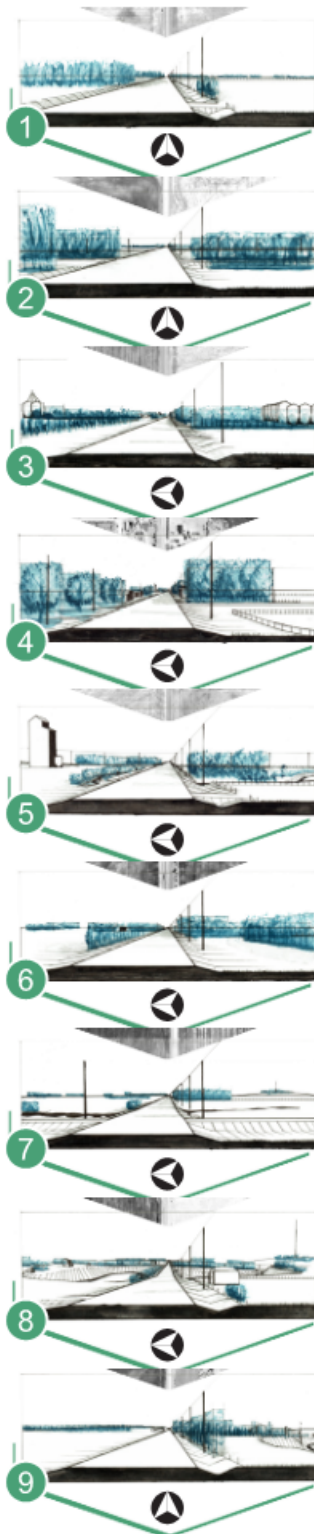

Vignettes of the procession route reveals a peripheral experience of the natural environment.

defined by a legal boundary, but in the fashion of medieval urban development, is directly associated to circulation within the prairie landscape. Procession through the community is thusly not definitive - but associative - in that rural community is proliferated through the rural grid. The grid represents a defining feature of the prairie landscape at a 1:1 scale, experienced from the ground or vice versa, at a 1:50,000 scale as experienced from an airplane. When a community becomes the focus for rural lifestyle, despite the economy of scale afforded by agriculture, the community is catalyst for shared values towards the environmental, social, economic, and cultural wellbeing of future generations both local and global.

Specifically, Warwick was once a robust rural community that developed a localized economy and social development as a result of the generational producers agricultural process. A victim of an anthropogenic trend towards rural exodus, the community retains distinct agricultural building typologies that can guide adaptations towards resilient community growth. These typologies may require a direct translation of program such as the community hall and the farmhouse, yet still require a modernization of building systems and user potentials to bring the generational farm to par with its urban counterparts. Built by the local farmers cooperative, typologies like the grain elevator are no longer a plausible value-add process for the generational farmer as the grain market is dominated by corporate agri-business. However, new commercial counterparts such as a biofibre decortication facility would require the same technological design efficacy required by a grain elevator, yet, would fulfill a greater role within the community. As traditional agricultural



A New Hemp Network in Warwick, Alberta. Locally established generational farmers gradually work industrial Hemp production into their agricultural process. Through field rotation, Hemp does not cloud existing food production, but assists in the environmental maintenance of the rural landscape and bolsters the image of a resilient rural community.

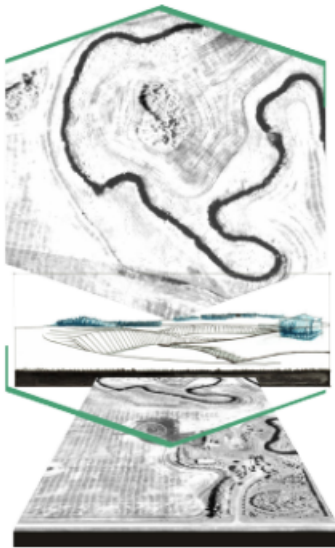

Study Site 2 and the Rural Community Center.

Departing from the regularly scheduled programming of an industrial rural landscape, a resilient rural landscape focuses on generating lifestyle attachment to sustainable community values. When placed directly into prairie ecosystems, consumers may develop similar experiential associations to the rural landscape as understood by rural producers.

practices are buried beneath socio-technical advancements every year, rural producers constantly reassert need and want to ensure that their process may endure.

To isolate what the prairie landscape can offer the rural producer and urban consumer, the architect will interpret associative relationships between the environment, social, economic and cultural implications of building a resilient rural community through Hemp. The following discussion will attempt to resolve the different design languages which have impeded sustainable agricultural buildings thus far. Most importantly, the architect must remember the lesson of Actor-Network Theory and the necessity for radical rationalization to ensure the greatest response of architecture to producer. As agriculture and the lifestyle it supports remain a complex and difficult organism to decipher, there is unlimited potential in the reinterpretation of established modes of design, dwelling, production, and consumption when applying simple associative principles.

Foremost, the configurative design principles and designing for reciprocity will inform a new architecture not only for Warwick community, but for Hempcrete as well. The greatest challenge to educating the consumer becomes how to translate design knowledge between such great scales of an ecologically diverse prairie landscape to a grain seed. Carried out at any scale, architecture and agriculture must assess the known possibilities for potential growth to positively affect the entrenchment of vernacular sustainability.

Apparent from the established conditions of the Weiss families generational farm sites (Grandparent, Parent,

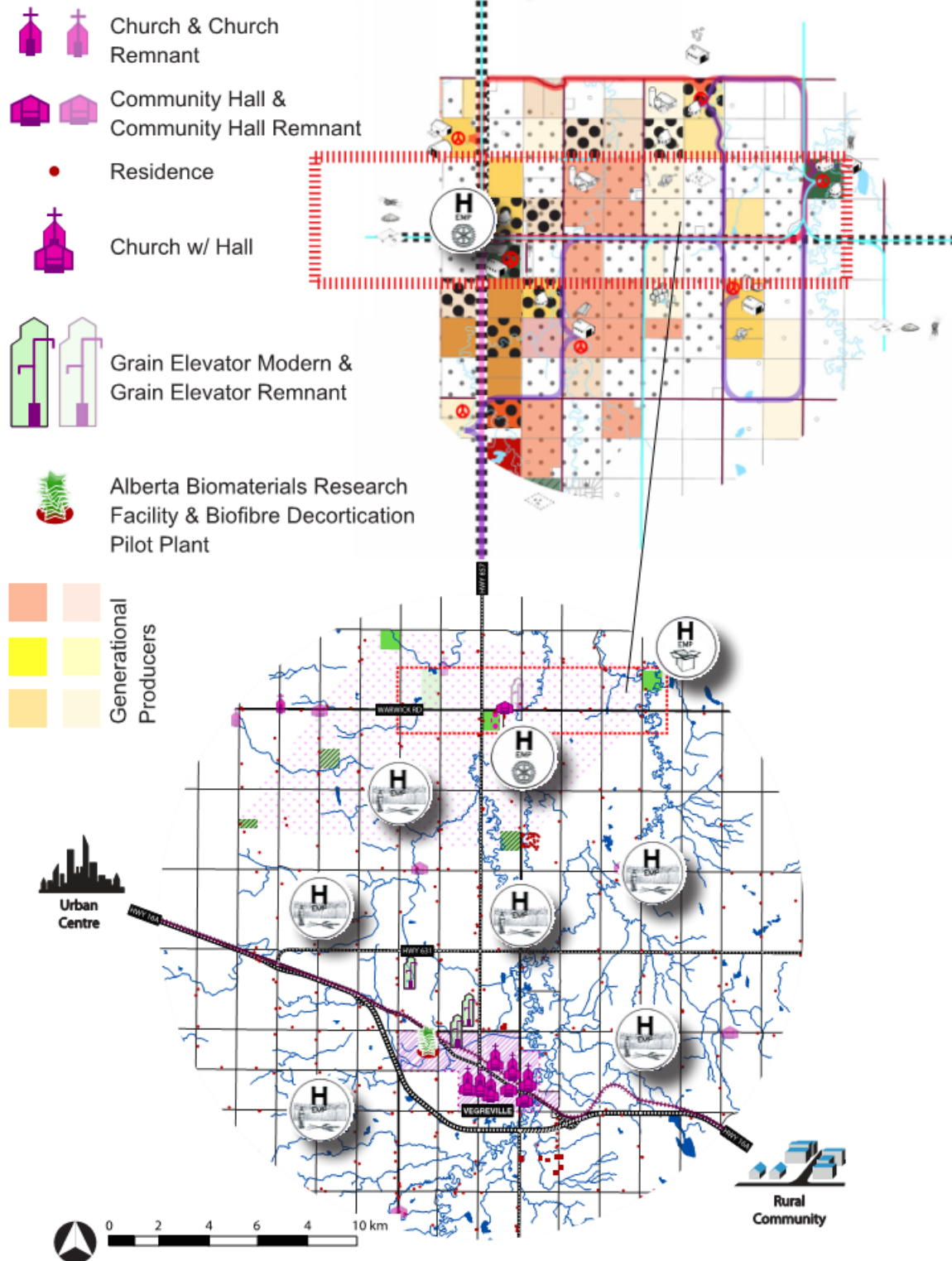

Strategizing a New Hemp Network.

The generational family farm is catalyst for a new Hemp network, radiating towards urban settlement and consumer markets to develop resiliency.



Reimagining the rural grid towards configurative design.

and Offspring Farm) is the transition of building form and program with each generations agricultural process. Given the suitability and direct association of the Vegreville community to the industrial Hemp process, developing new associative networks for Hemp seems obvious. Through the analysis of independent technological and sociocultural systems that comprise Alberta, it is obvious that the rural producer retains a single venue to assert their significance to any greater eye, ear, tongue, or nostril - the productive landscape. Above all else, the rural producer must relearn the idea of productive surface to return a greater value to the environmental, social, economic, and cultural perception of the prairie landscape. In this sense, the architect is given the site of a quarter section and its potential subdivision to organize the consumers procession and perception of how generational family farms can positively affect urban lifestyle.

The objective of this section is to represent how a sustainable Hemp network would function within the existing rural fabric of Alberta. As the prairie landscape represents an associative site condition, the generational family farm represents rural community and the consumer represents urban growth. In the spirit of reciprocity, the architect must define the parallel synonyms to design between and will draw from the established systems which compose the Alberta lifestyle.

Rural Landscape_Environment

To be precise, the agricultural process is entirely dependent upon the various systems which collaborate and result in an agricultural product. These systems are not closed-

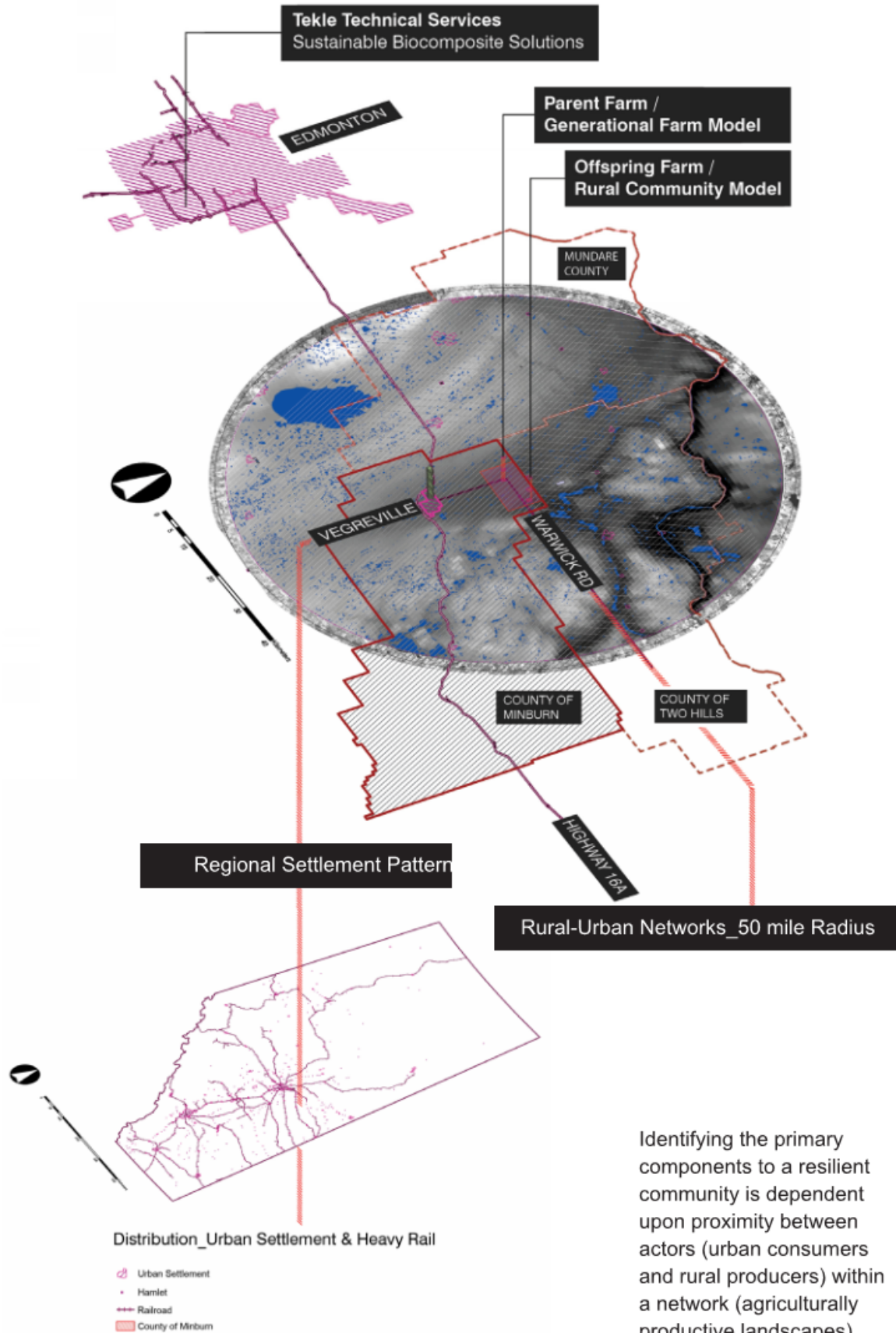

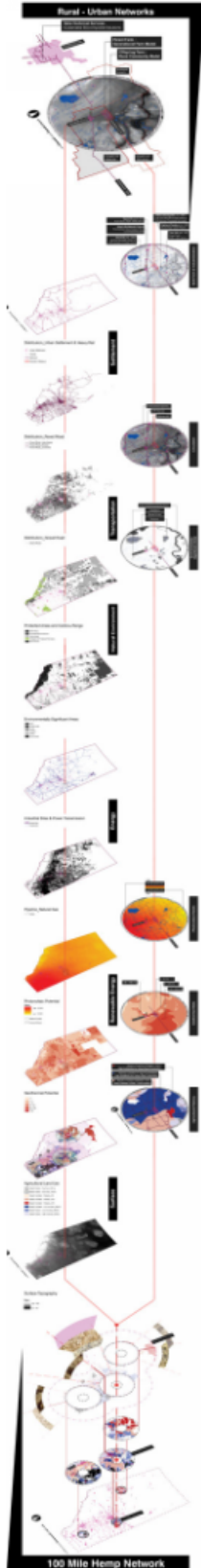

Rural Systems & the 100 Mile Hemp Network.

loop, but open-loop, and often depend upon technologically and socially associative systems which define a producers process. As agriculture is delimited by natural environment, the producer defines how the resultant interaction of energy, production, circulation, and consumption may benefit their process. What is understood of industrial agriculture is that fewer and fewer options remain for the rural producer to define their systems of production and consumption. Albeit, producers reduced efforts are delimited by the amplification of petrochemical toxins which contribute to environmental decay - the result of economic and social limitations imposed by rapid urban growth that does not account for rural residency or sustainable productive landscapes.

In defining how a sustainable rural process (low-

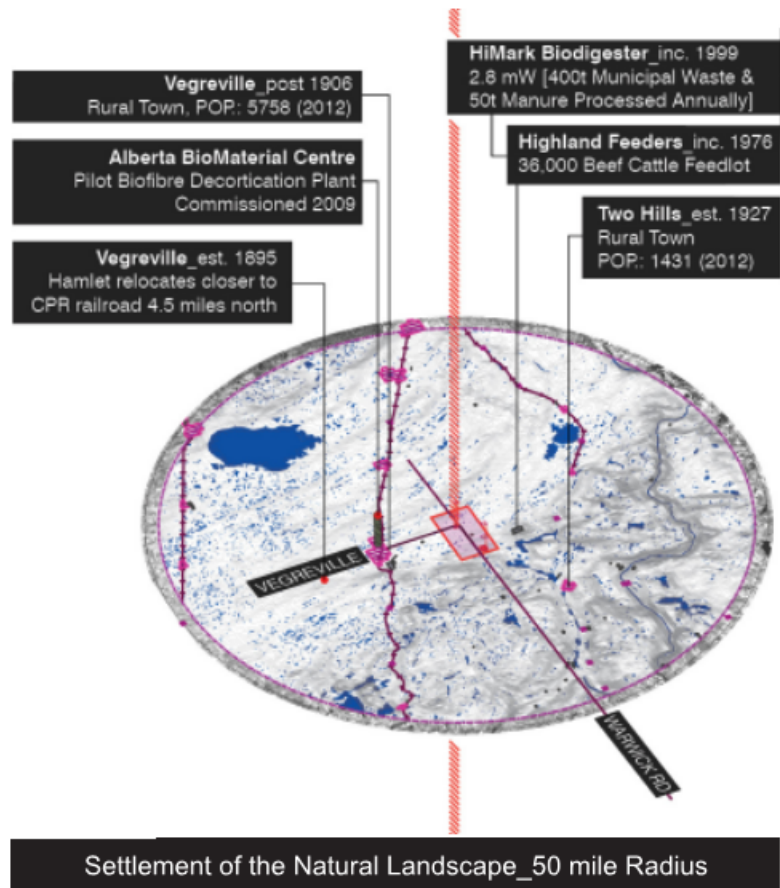

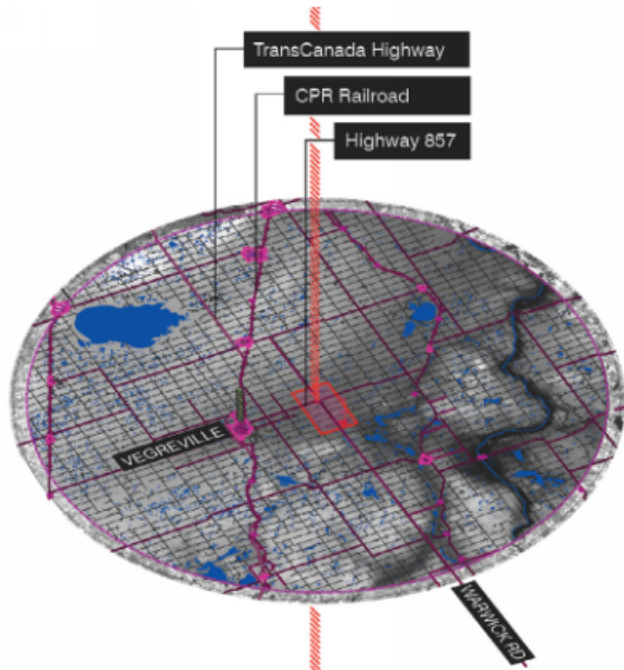

Circulation_50 mile Radius

Circulation corridors must respond to natural landscapes, often bisecting natural systems for circulation such as water bodies and forest corridors. The intersection of consumer and producer pathways with natural systems is the proprietary visualization of the rural landscape within Alberta's prairie systems.

Consumer Proccession

Industrial Proccession

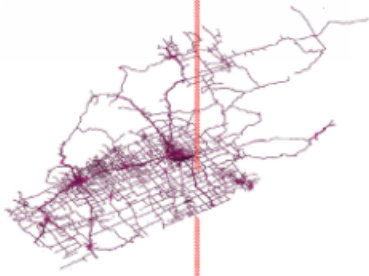

Distribution_Paved Road

- Paved Road_Interchange
- Paved Road_Divided
- Paved Road_Undivided

Industrial Sites & Power Transmission

- Industrial Sites
- Powerline Grid

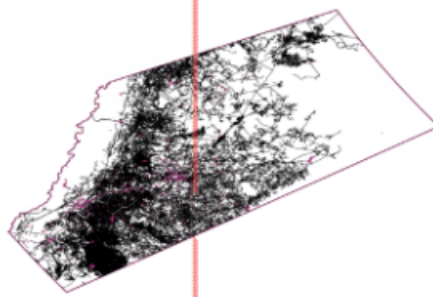
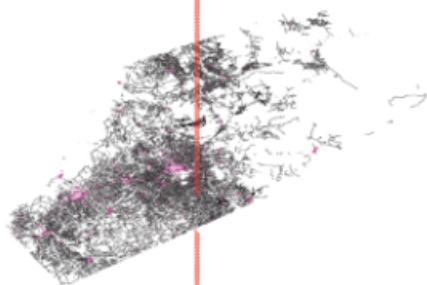

Distribution_Gravel Road

- Gravel Road

Pipeline_Natural Gas

- Pipeline

Producer Circulation

Energy Circulation

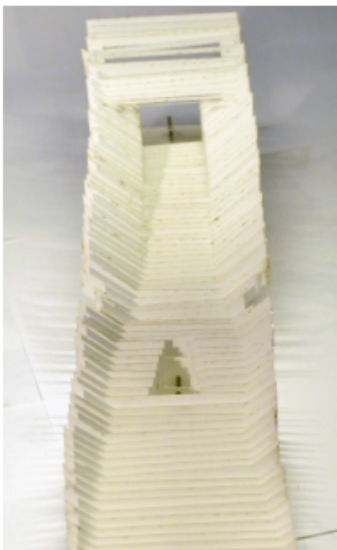
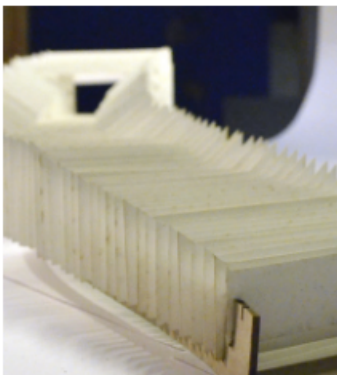
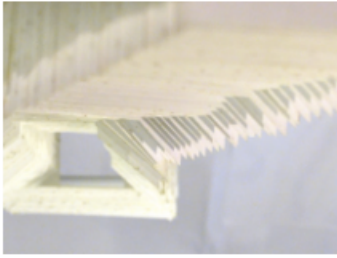

Barn Module Roof Model demonstrating how built form and process can inform intermittent visualizations of a rural landscape.

carbon community) may replace an industrial agricultural process (high-carbon community) there are very important considerations that only direct consultation with community members will reveal.¹⁰² The greatest challenge is compensating rural producers for investing in a sustainable agricultural process. If new producer-consumer systems are to competently integrate into established environmental systems of Alberta and expect any retention or repetition of its lessons for resiliency, than new systems must acknowledge the established systems for natural systems, urban settlement, and regional distribution. What these systems represent is a pattern for industrialization as community development is structured upon resource generation and retention.

Given the current mappings of Alberta and subsequent systems, it is important to remember that the first settlements occurred along natural water bodies that could sustain multiple forms of industry. As the technology of industrialization prevailed, dependence on natural systems devolved leading to present social precepts of agricultural process. Given that entire crops can be

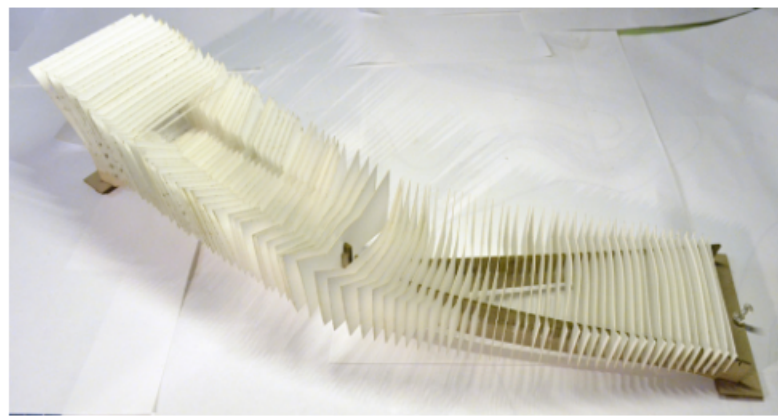

102.Coyle, *Sustainable and Resilient Communities: A Comprehensive Action Plan for Towns, Cities, and Regions*, 25-26.

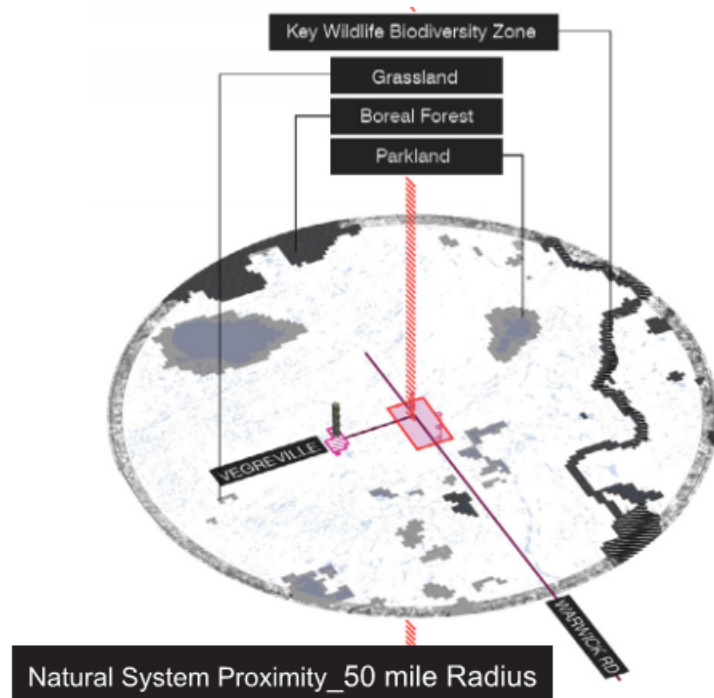

Assessing the proximity of natural systems will benefit the producers sustainable process. As well, it is important to site decortication facilities within viable producer networks that can maintain commercial production quotas. This means that land areas nearest the facility can adequately provide enough raw product, and that the agricultural process does not interfere with established systems for environmental protection and revitalization.

Natural Habitats

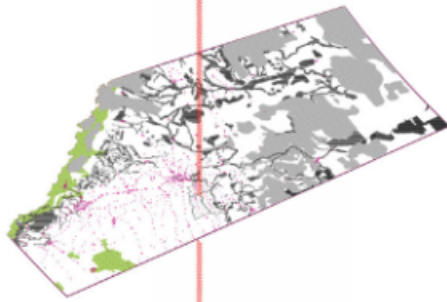

Solar Energy Platform

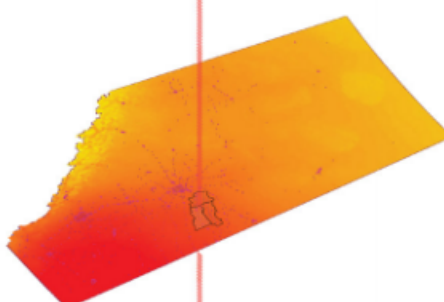

Protected Areas and Caribou Range

- Wildlife Refuge
- Key Wildlife Biodiversity Zone
- Caribou Range
- Ecological and Threatened Plant Species
- Native Reserves

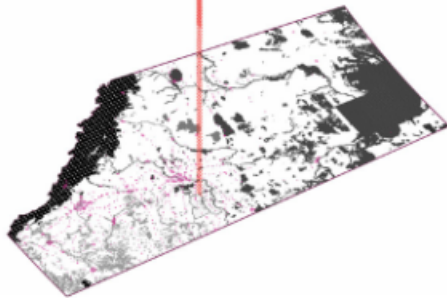

Photovoltaic Potential

- Value
- High: 10,000
 - Low: 12,000
- Adjacent Counties
 - County of Miramichi

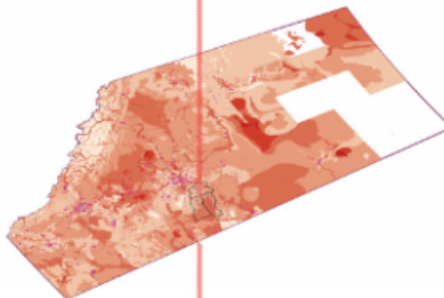

Environmentally Significant Areas

- Riparian
- Canadian Shield
- Possible
- Overland
- Parkland
- Rocky Mountain



Geothermal Potential

- < 1
- 1-5
- 5-25
- 25-100
- 100-300
- > 300

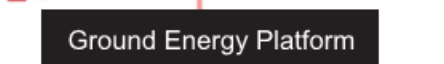

Ecological Biodiversity

Ground Energy Platform

distinguished following a single event of hail, frost, or pestilence, producers must compensate by producing more product and thusly rely upon industrial process to remain competitive. Essentially, a sustainable agricultural process must not diminish the ability of the producer to produce, and if so, compensations for extra labour inputs, research and development of sustainable alternatives, relative cost and profit, and new product development must be accounted into new systems to ensure their uptake by rural producers.

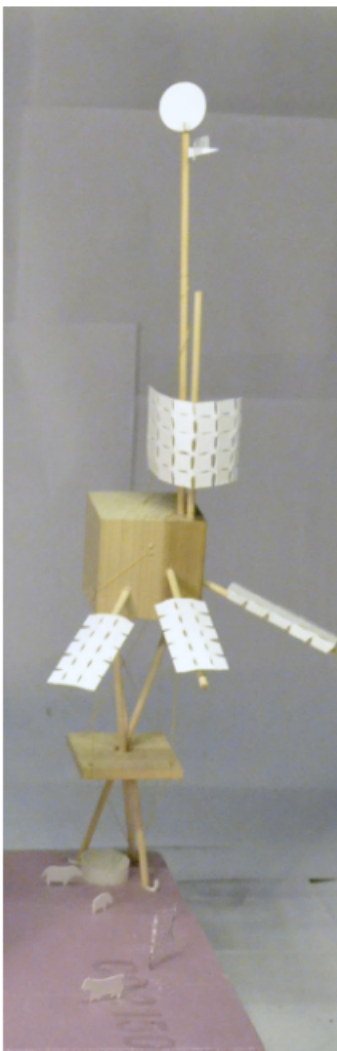

Concept Model for the RE-Tower.

As well, ecologically significant areas important to ensuring prairie biodiversity must be identified for their adjacency to current agricultural communities. Industrial agriculture has proven to upset natural systems as residual fertilizers promote unnatural growth of algae in water bodies and latent chemical deterrents are introduced into the food chain. What this means to designing new rural architecture is an idealism for building systems that do not introduce unnecessary pollutants into natural systems, and that could potentially offset the necessary expenditure of non-renewable energies needed to produce the agricultural product. Given Hempcrete's hygrothermal properties and hydraulic limes chemical process of calcification, CO_2 is removed from the air passing through the wall surface, strengthening the wall and sequestering CO_2 simultaneously. The encased Hemp shiv is petrified, turning to limestone. This means that Hempcrete naturally repairs and strengthens itself with time - much like the generational farming process.

In discussing environmental systems that will influence a sustainable agricultural process, it is important to consider these systems as the pre-existing influence

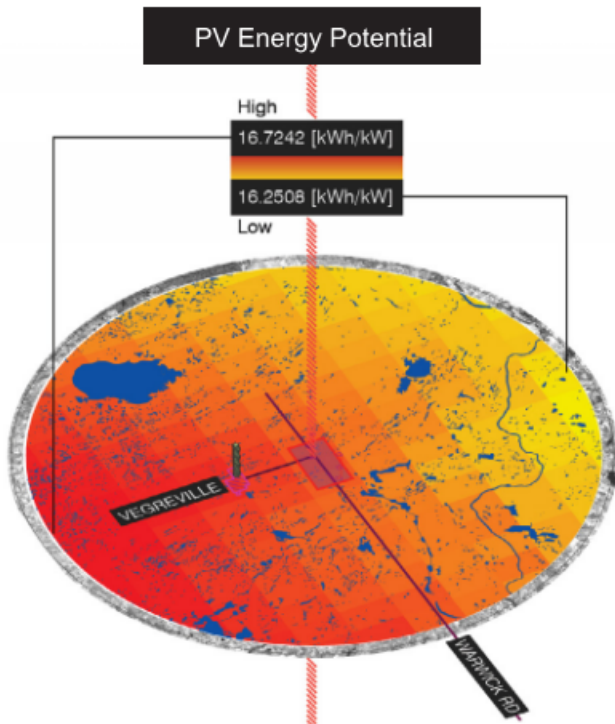

Analysis of PV Solar potential in the 50 mile radius reveals that this Hemp network epicentre can adequately generate renewable energy for rural producers. This signifies that a new agricultural process should incorporate PV energy systems into rural communities

Natural Energy Associations _50 mile Radius

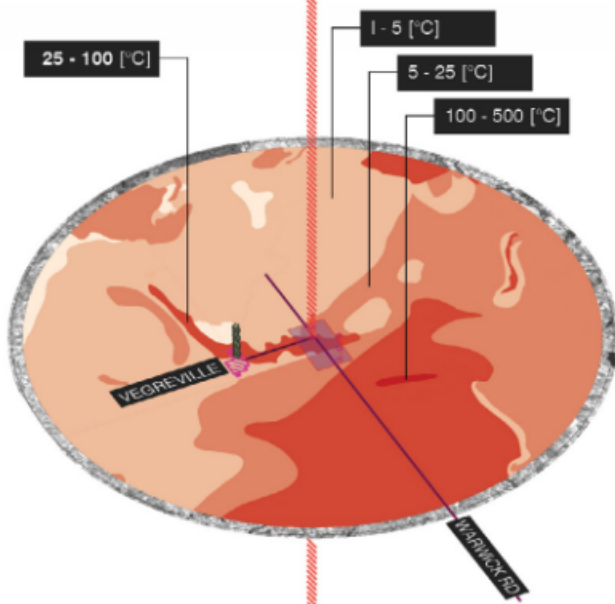

Geothermal Energy Potential

Geothermal energy mapping reveals that the design sites of the Parent Farm and Offspring Farm are ideally located to utilize geothermal energy in their process. Although not potent enough to be converted to electricity, enough thermal energy is present to adequately heat agricultural buildings and reduce producer energy needs.

Complex systems are revealed in moments where inputs become outputs. Animating the rural experience requires distillation of sensory experience.



Concept Model for
Hempcrete Barn Module.

to the built environment and anthropogenic process. As such, all anthropogenic systems are built into the natural world and can affect the producers process to some extent - especially when considering the role of the machine to the agricultural process. Identifying the regional to local interception of a Hemp network within established systems of rural production will verify the Hemp networks viability to local communities and the region. There are three specific indicators that designers should look for in validating Hemp networks; established rural communities, proximity to urban consumers and suitability of productive landscapes to new process.

Assessing proximity of process to established form is the basis for designing sustainable rural communities. The main objective of low-carbon communities is to reduce the consumption of fossil fuels and thus, reduce the exertion of greenhouse gases. As previously discussed with Tam Tekle, travel distances between field, facility and shelf should encompass a 100 mille radius from an epicentre of material processing, establishing a definable network area and the planning of subsequent Hemp networks. More so, producers are not restrained to single point processing facilities that require greater investment in storage and transportation of raw product. As such, commercially produced materials must meet a standard quality for consumption and ensuring product quality becomes the responsibility of the producer until raw product can be sold to a processing facility. This ultimately means that Hemp producers must align their process to commercial applications early in the design stage, and, must develop a reproducible product and process to ensure the greatest returns on investment.

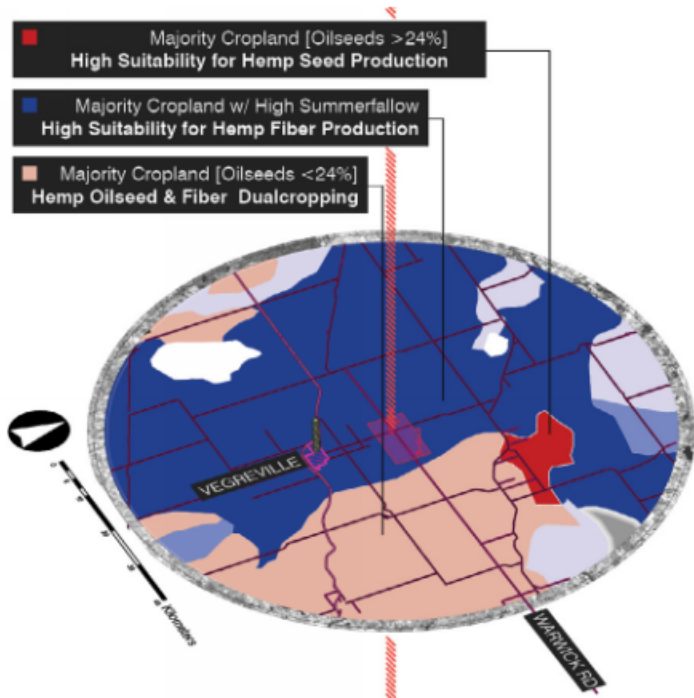

Agricultural Landscape_50 mile Radius

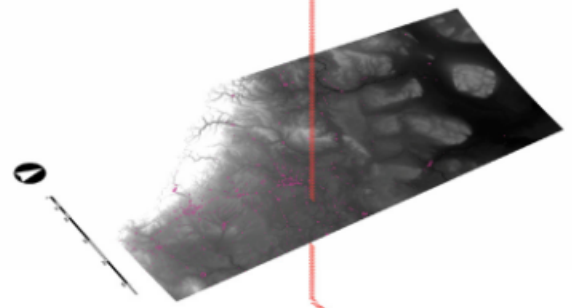
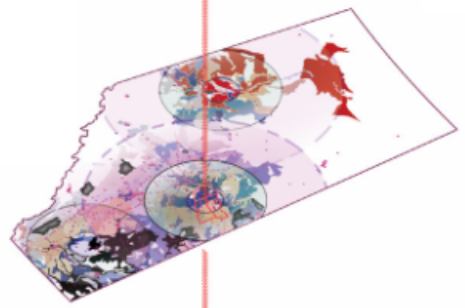

Natural Landscapes

Currently, the rural landscape and its communities are dominated by an industrially agricultural process. What this map reflects is the viability of the local productive landscape towards producing seed and fibre crops within the network. As well, given a 100 mile radius for a sustainable network, it is clear that Alberta could viably sustain three Hemp networks.

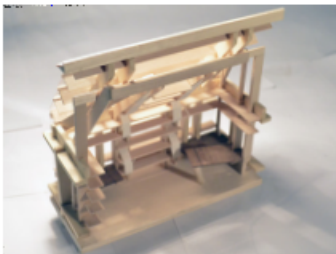

Concept Model for
Kitchen/Greenhouse.



Concept Model for the
Lookout Tower.

One continuing thread of this thesis document seeks multiplicity of design, product and effort to ensure future generations participation in these systems - the direct integration of producer cycles with ecological cycles and natural habitat. This means that one decortication facility is meant to multiply across the region as consumer habits entrench Hemp within their lifestyle. Subsequent rural communities will develop to support processing facilities and promote the agricultural product as a mode of lifestyle. This is not to say that the product is life, but, that the product assists all forms of lifestyle. Association of product to systems like circulation, environment, culture, and economy strengthens the consumers interpretation of the product to a regional system of production, and the role of those systems towards the producers process. As well, learning these systems invariably allows the consumer to relate directly to producers needs and to begin rationalizing those systems to their own needs.

Analyzing the inherent systems which support the agricultural process in Alberta reveals a similar multiplicity of form and process throughout associated systems of circulation, natural landscape, energy, and urban settlement. Other systems that occur naturally yet require intrinsic knowledge and specialized mapping include soil typology for agricultural suitability, photovoltaic potential for solar energy harvesting, and geothermal energy mapping to assist low-energy building systems. Ultimately, the architect-planner must provide new information platforms for rural producers to assist their sustainable agricultural process - platforms derived from naturally occurring processes like solar and geothermal energy - derived from the agricultural process

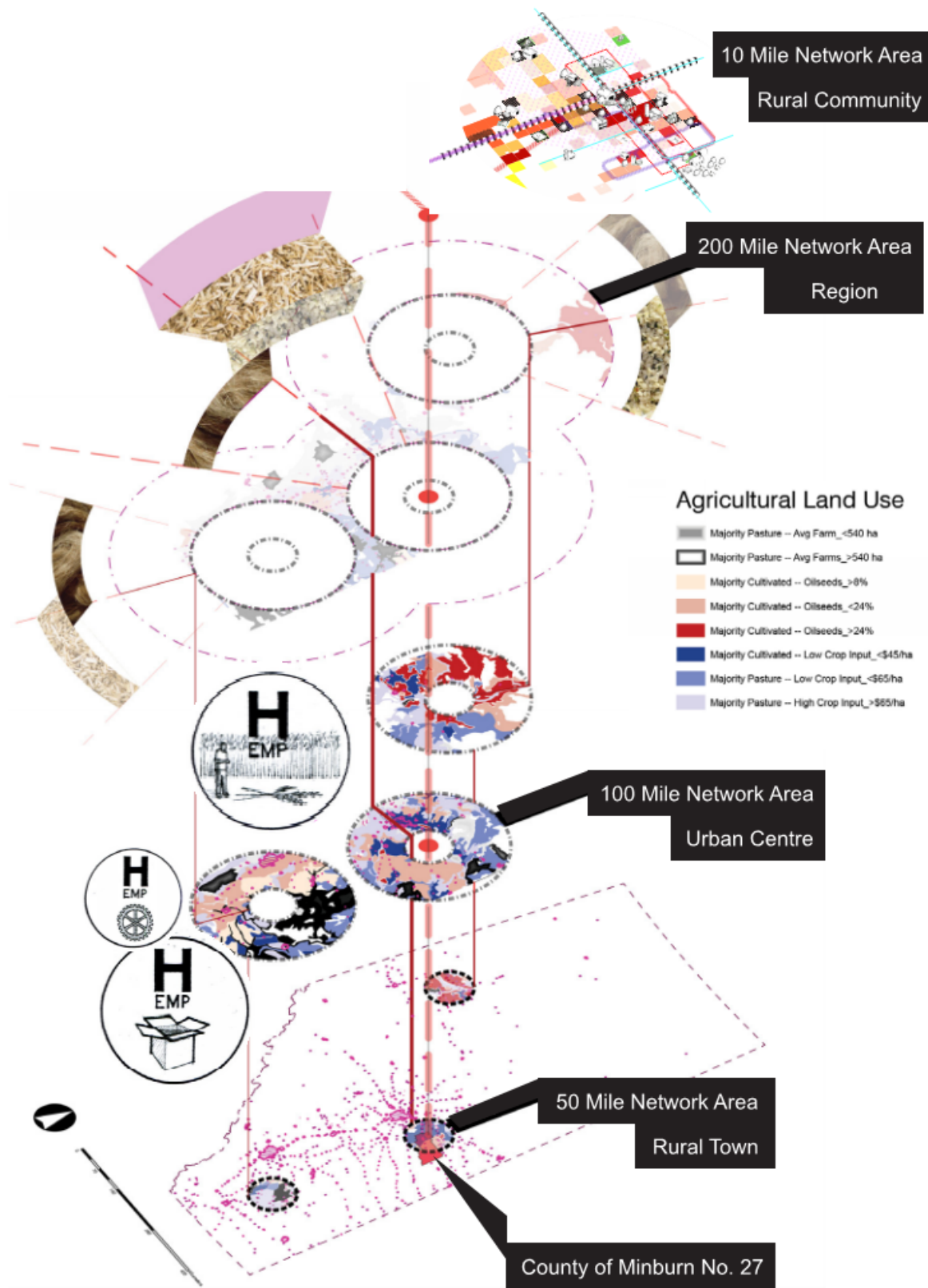

Alberta Hemp Networks.

Catalyzed in rural communities, the Hemp network is generated to encompass the prairie region, providing locally developed, value-add Hemp products to consumers.



Concept model for the Consumer Tube.

itself. It is understood that agriculture demands great areas of land and energy to remain economically viable, and as such, the implication of local Hemp networks is intended to offset the ecological costs of other products.

Foremost, the analysis of these systems is to verify the associative networks which already connect consumers and producers in Alberta. These systems proliferate the prairie landscape engaging the lifestyles of many individuals, and should be considered as the basis for new architecture. Specifically, the automobile and circulation paths are the most critical to organizing urban consumers engagement of the producers efforts. One critical observation of existing systems within Alberta is that integral notions of energy distribution and consumption follow established settlement patterns, tracing the same pathways for circulation - traces of the rural grid.

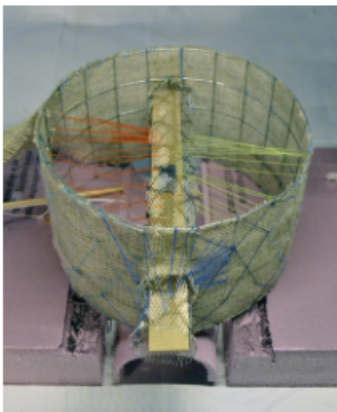

Concept model for the Granary, incorporating the consumer directly into the producers process.

What is understood of Alberta's transition into industrial agriculture is that pre-existing systems were adapted and compensated for until they could be replaced by more efficient technology and process. Environmental systems such as circulation, natural landscape and settlement have changed so much in response to centralizing services and densifying domesticity. Economic, social and cultural systems were more susceptible to change within the urban realm, as they were most visible to the urban consumer. As such, rural landscapes change at a decayed rate in response to urban growth - an echo - as rural producers must bear the weight of change.

Overall, synthesis reveals that three distinct Hemp networks could be developed within the northern, the east

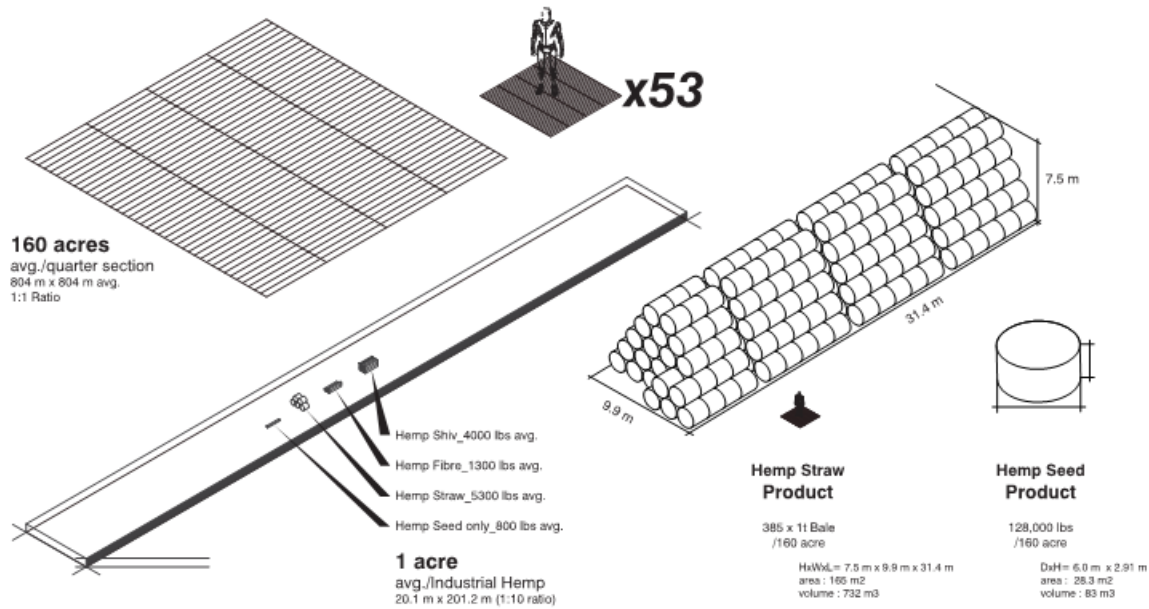

Productive Landscape -- Modular Hemp Crop Single Producer -- Output

Alberta Hemp Production.
Catalyzed in rural communities, the Hemp network is generated to encompass the prairie region, providing locally developed, value-add Hemp products to consumers.

Average Field Production_Industrial Hemp_Vegreville, Alberta

	lbs/acre	tonne/ acre	Quarter Section lbs/160 acre	tonne/ year
Avg. Seed Yield	800	0.3628736	128000	58.05978
Avg. Straw Yield	5300	2.4040376	848000	384.646

Yearly Production Capacity From 4 month Hemp Crop Production Cycle

10 tonnes / hour @ 8 hours/ day 5 days @ 51 weeks
= 255 days

Feedstock Processing Capacity	10	tonnes/hour
Avg Daily Operation	8	hours/day
Avg Daily Processing Capacity	80	tonnes/day
Avg. Yearly Processing Capacity @ 255 Days	20400	tonnes/year

Acres Required to Sustain Annual Production Capacity

Production Capacity	20400	tonne/ year
Bales Required	20400	bale/year
Quarter Section / Producers Required	53	(+/- 2)



Hygrothermal



Economical

Super
InsulativeMold
ResistantFire
ResistantPest
Resistant

central, and the southern regions of Alberta. Each network is already agriculturally developed and within proximity of major urban centres, connected via rail and highway corridors. Specifically, these network epicentres could become product distribution centres to northern and western Canada, and to the United States. Likewise, Hemp networks developed in Saskatchewan and Manitoba would strengthen a Canadian Hemp industry, backed by Hemp hungry American markets. Provision of decortication facilities is critical to initiating Hemp networks and subsequent biofibre products. Much like a road connects two communities, Hemp networks can connect consumers to producers and the urban to the rural lifestyle.

Rural Networks_Economic

Urban settlement and proximity to food resources is critical to reducing non-renewable energy dependency, enticing a ripple effect through multiple systems and lifestyles. By generating new epicentres for sustainable product development adjacent to urban centers, transportation distance and cost is reduced - leading products to be designed to local ecological capacity and consumer need. Furthermore, developing a sustainable agricultural process can lead to a reduced food costs overall as producers limit their dependence on costly chemical additives and return to natural landscape processes. Incremental development of consumer markets allows entrepreneurs to value-add their process and product in its stages of adolescence whilst simultaneously developing a brand name. As well, consumers are given time to assess and respond to new products, generating user knowledge that is made readily

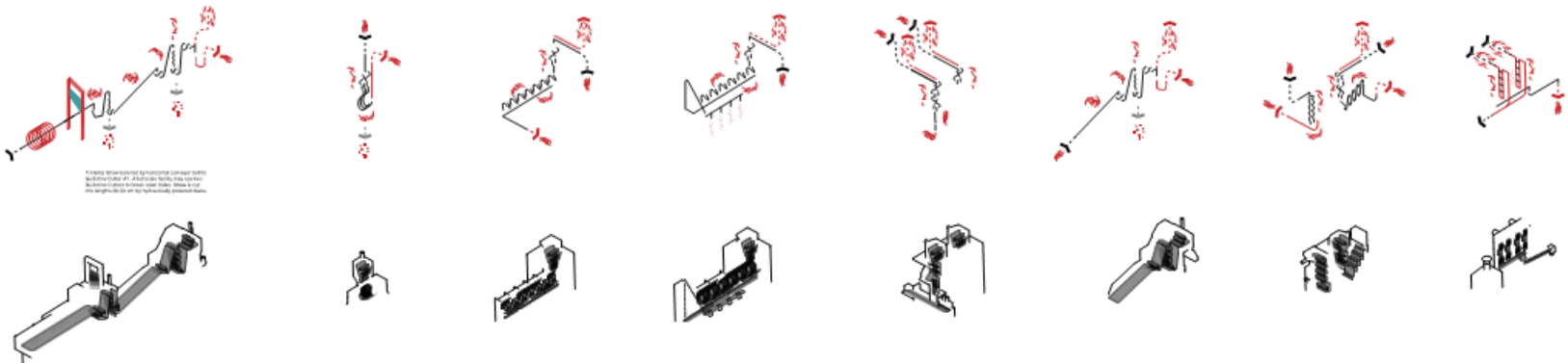

1 Bale Conveyor & Guillotine Cutter 2 Loader & Opener Feed Preparation 3 Hammer Crusher Decortication 4 Duvex 1 Fibre Cleaning 5 Duvex 2 Fibre Cleaning 6 Fiber Press Fiber Packaging 7 Second Opener Refinement Line 8 Fine Opener & Step Cleaner Refinement Line 9 Ventilator Dust Filtering

Decortication Equipment Schedule and Process. Defining the spatial requirements and material flow of the Hemp decortication process.

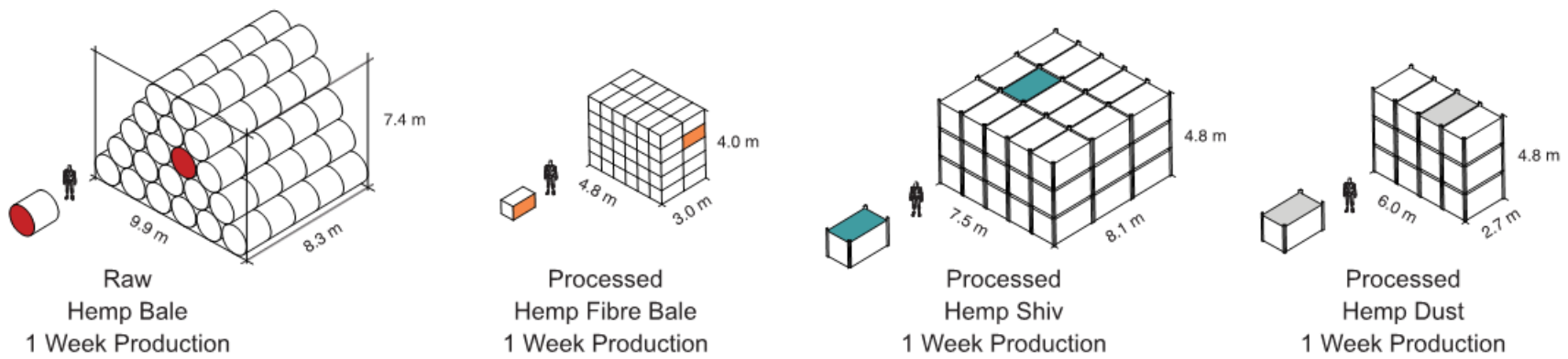

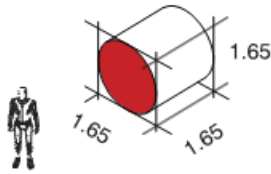

Raw
Hemp Bale
1 Tonne

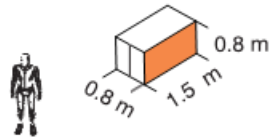

Processed
Hemp Fibre Bale
1 Tonne

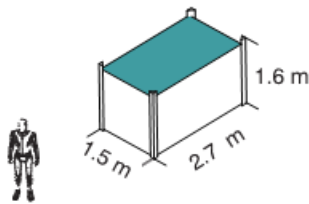

Processed
Hemp Shiv
1 Tonne

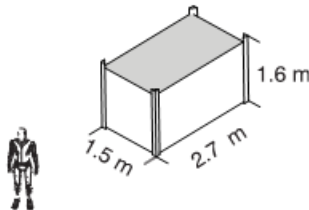

Processed
Hemp Dust
1 Tonne

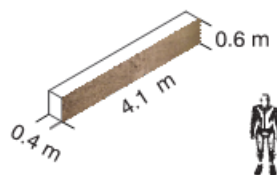

Finished
Hempcrete Wall
1m³

available to consumers via social media and cultural practice. Speaking in economic turns, products developed directly in the field respond directly to 'need', and in turn, can inspire 'want'.

Given Hems popularity and intrinsic social value, recognized prior to its illegalization, many resources and information on Hemp and Hempcrete have already been made available to the public. However, much of this information is too technically convoluted, or, over simplified.

Hemp Straw_1t Round Bale

Weight	tonne	1
Diameter	m	1.65
Area	m ²	2.14
Volume	m ³	1.9
Stack Limit	bales	6
Weight	t/m ²	0.89

Hemp Fibre_High Density Bale

Weight	tonne	0.4
H/W/L	m	1.5x.8x.8
Area	m ²	1.2
Volume	m ³	1
Stack Limit	bales	6
Weight	t/m ²	0.33

Hemp Hurd_1t Processed Wt.

Weight	tonne	1
H/W/L	m	1.47x1.47x2.56
Area	m ²	2.16
Volume	m ³	5.5

Building program development based on agricultural process input and outputs.

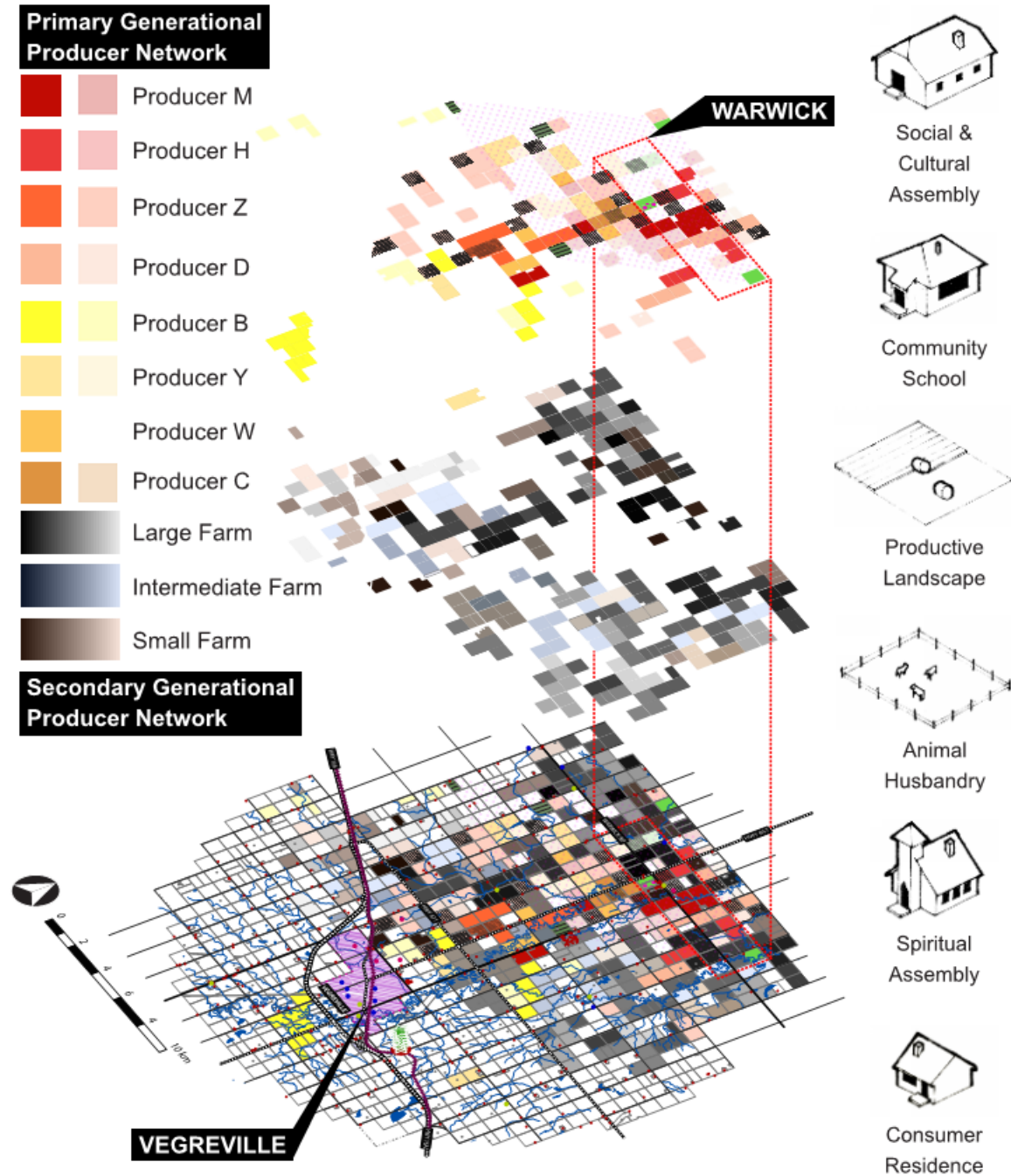

Mapping a New Hemp Network from existing generational producer networks of the rural community and degrees of association. Described as the brick allure, rural communities develop a vernacular form of vernacular building process through direct relationships to families, neighbours, and communities. Speaking in economic turns, initially, a handful of producers is needed to implement a local Hemp network, deciphering the plants eccentricities until a sustainable agricultural process is defined. Eventually, producer networks and direct experience of the plant in the productive surface will generate interest and association in rural networks. What is most important is the catalyzation of the industrial Hemp process in terms of rural capability and not in terms of industrial capacity.

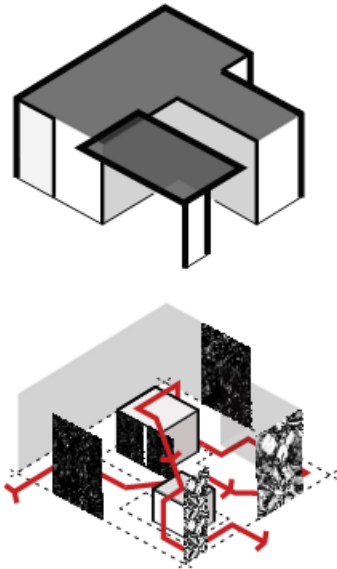

The Simple Model.
How does the consumer
traverse the Hemp network
and learn the Hemp process?

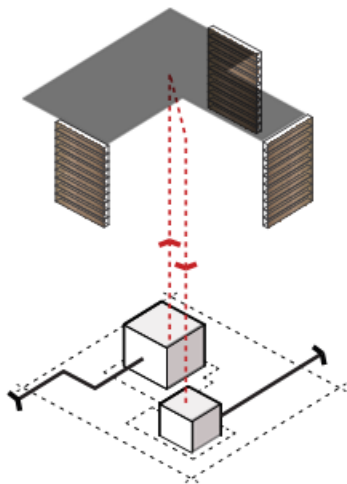

As the decortication process
utilizes pneumatic piping to
maneuver Hemp material
through the facility, the floor
plan is not fixed to one linear
process but is coordinated
on the maneuverability of
products in and out of the
building.

Clear demonstrations of Hems validity within sustainable communities must be made apparent, supported by recognized community figures and professional representatives who recognize what Hemp can become.

Foremost, the architect-entrepreneur must accommodate reciprocal perspectives of producer need and consumer need. Consumers demand cost effective products yet will invest more into resilient and trustworthy products that fulfill more than physical need alone. Thusly, this is the interception of product and experience where social, cultural, or environmental concerns overcome economic. This is the ultimate objective of the rural producers sustainable process, in that consumers demand the producers service and knowledge above conventional retail outlets. Alternatively, producers demand higher returns for their investment into agricultural product; typically implementing cost reductions in the agricultural process itself. Hemp provides an abundance of raw agricultural product and sustainable attributes that can assist the transition of high carbon rural communities into low carbon communities, directly affecting the economic resiliency of those communities.

If consumers and producers can negotiate real value and cost of effort for product, than economic consensus can be reached. Sustainable economies are regenerative in that local producers provide valuable service to their

Monetary Returns for Hempcrete Consumers.
Data sourced from: Alberta Agriculture and Forestry. "Industrial Hemp Production in Canada." Last modified June 20, 2016.
[http://www1.agric.gov.ab.ca/\\$department/deptdocs.nsf/all/econ9631](http://www1.agric.gov.ab.ca/$department/deptdocs.nsf/all/econ9631)

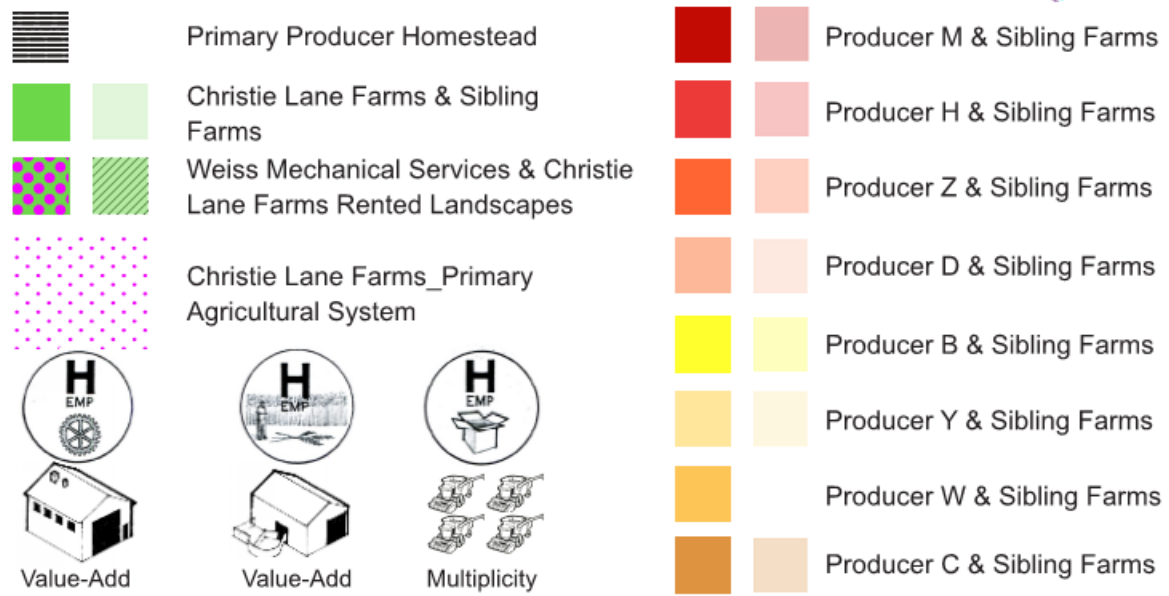
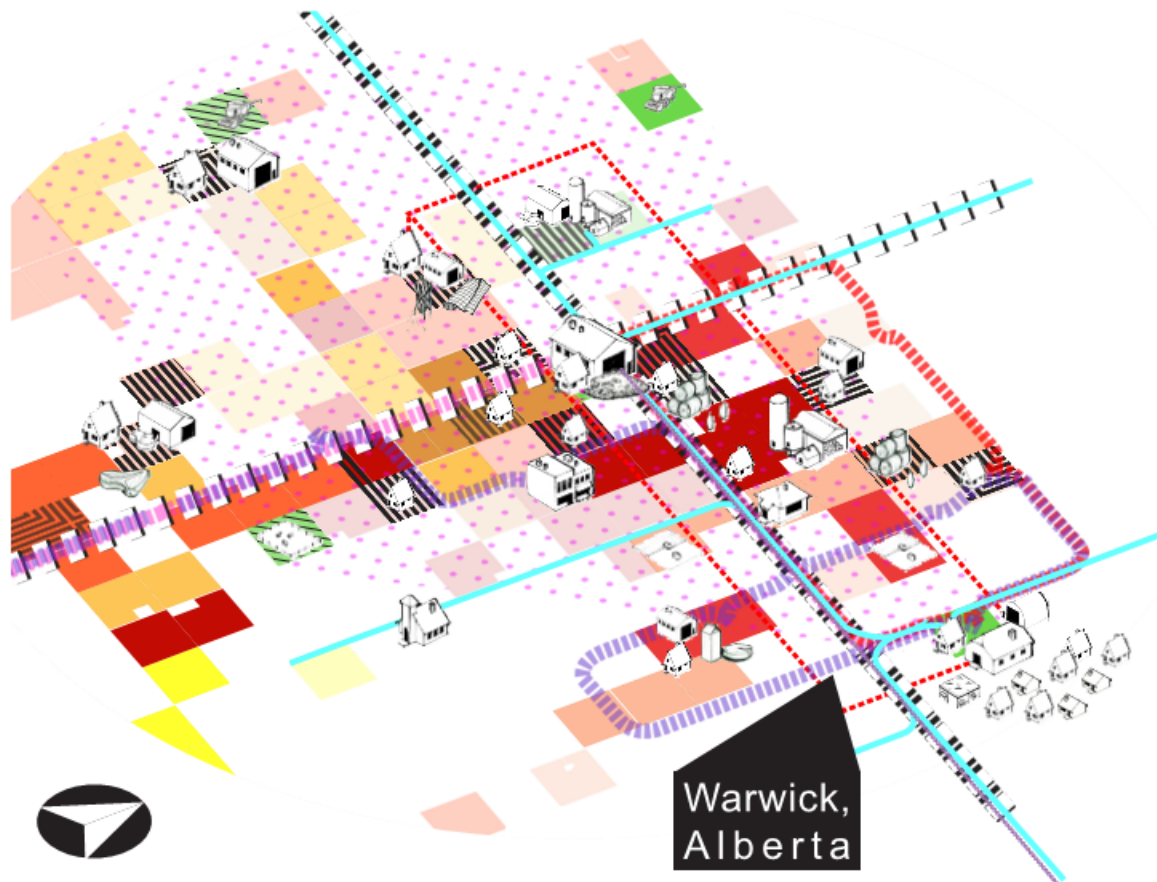

Local Typological Product

Mapping the Hemp network and the consumers immediate exposure to a sustainable rural community - a community that develops value-add products for local and regional consumption. As rural producers utilize Hempcrete buildings to assist their sustainable agricultural process, consumers are exposed to multiple applications that assist a Hemp network economy.



Hemp
4 part



Water
1 part



Lime Binder
1 part

Hempcrete Composition. Hempcrete is a mixture of the Hemp stalk core, the shiv, and a natural cement, the hydraulic lime binder. It is critical that the shiv is thoroughly coated in lime binder to ensure the petrification of the shiv aggregate as the binder calcifies, continuing the process of CO₂ sequestration. The construction process of Hempcrete makes it an easily learned building trade that rural producers can easily adapt to many regional ecologies. Buildings designed with Hempcrete present new opportunities for energy efficiency and sustainable building technologies.

community and are supported for their excellence in providing that service. When this service extends from food, or is associated to the social and cultural experience of food, then real value and cost is more easily assessed. The reality of North American society is that rural producers and urban consumers have become so dependent upon established economic and production systems, that new systems appear unstable or unnecessary.

When defining the literal arguments for producers and consumers to adopt and support Hemp networks, real figures demonstrate high rates of return for producers, as the entire Hemp plant can be processed and directly utilized in industrial, commercial, and residential products. Immediate economic returns to producers ensures their participation in Hemp production and the establishment of infrastructure that supports a Hemp network. In terms of architecture, this infrastructure is represented by buildings and agricultural programs that exemplify local capacity for sustainable and low energy rural communities.

For communities to fully embrace Hempcrete as a vernacular building material, the architect-planner-entrepreneur must understand the unbearable weight that economics plays into the rural producers decision making process. As such, Hempcrete is a highly economical building material that naturally exhibits many functions

Wall thickness (mm)	Wall thickness (in)	U-Value (k*m²/w)	R-Value (1h*ft²*°F/Btu)	RSI Value (0.176)
300	12	0.23	25	4.35
400	16	0.18	33	5.56
500	20	0.14	50	7.14

Thermal performance of Hempcrete wall systems.

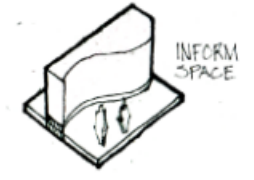
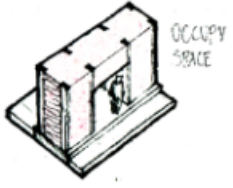
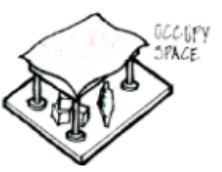
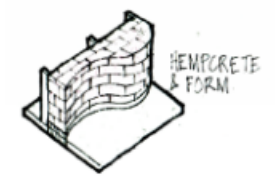
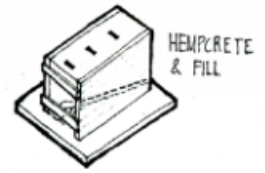
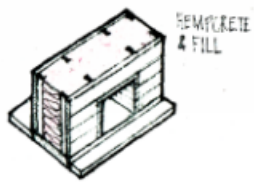
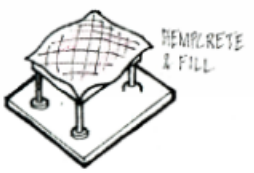
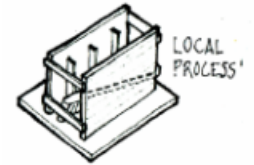
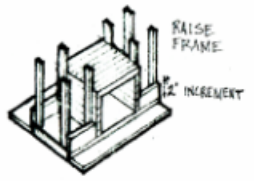
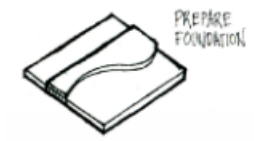
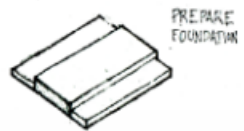
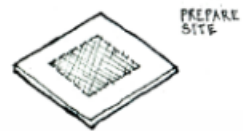
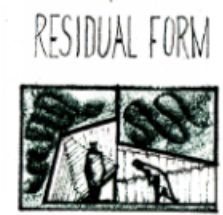
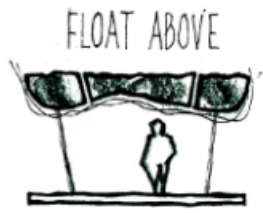

Modes of Building and Dwelling With Hempcrete. Strategies for construction typologies of Hempcrete buildings and rural resiliency integrate multiple Hemp products and program relationships to create new typological associations.



of contemporary, non-sustainable building materials. As Hempcrete structures begin to signify rural resilience, urban consumers may begin to assimilate that process into the urban fabric. Foremost, the Hempcrete wall system is affordable because it integrates many separate and necessary envelope components into one holistic wall construction. Aside from being a low cost, simplified building construction, Hempcrete regulates interior humidity and temperature which greatly affects energy usage throughout the year. In the sense of economics, Hempcrete fulfills roles of producer/consumer 'need' and 'want' by providing a low cost building alternative and by creating local market economies through product association and branding. Architectural design for generational family farms and derivative communities will accelerate the branding process, catalyzing Hemp as a community building resource.

	\$/lb	\$/tonne
Hemp Seed	1	2204.62

	\$/lb	\$/tonne
Fibre	0.30	660.00
Shiv (clean)	0.18	396.00
Shiv (w/ fibre)	0.12	269.00

avg. cost of hemp shiv (\$/lb)=	332.50
---------------------------------	--------

	Cost of Hempcrete Wall (\$)	
Hemp	(.15/lb)	60.48
Lime	(.56/lb)	56.82

Avg. cost of HEMPCRETE (1m ³)	117.30
---	--------

Monetary Savings for Hempcrete Consumers.
 Data sourced from: Alberta Agriculture and Forestry. "Industrial Hemp Production in Canada." Last modified June 20, 2016.
[http://www1.agric.gov.ab.ca/\\$department/deptdocs.nsf/all/econ9631](http://www1.agric.gov.ab.ca/$department/deptdocs.nsf/all/econ9631)

- Closet
- Bathroom
- Kitchen
- Bulkhead
- Window

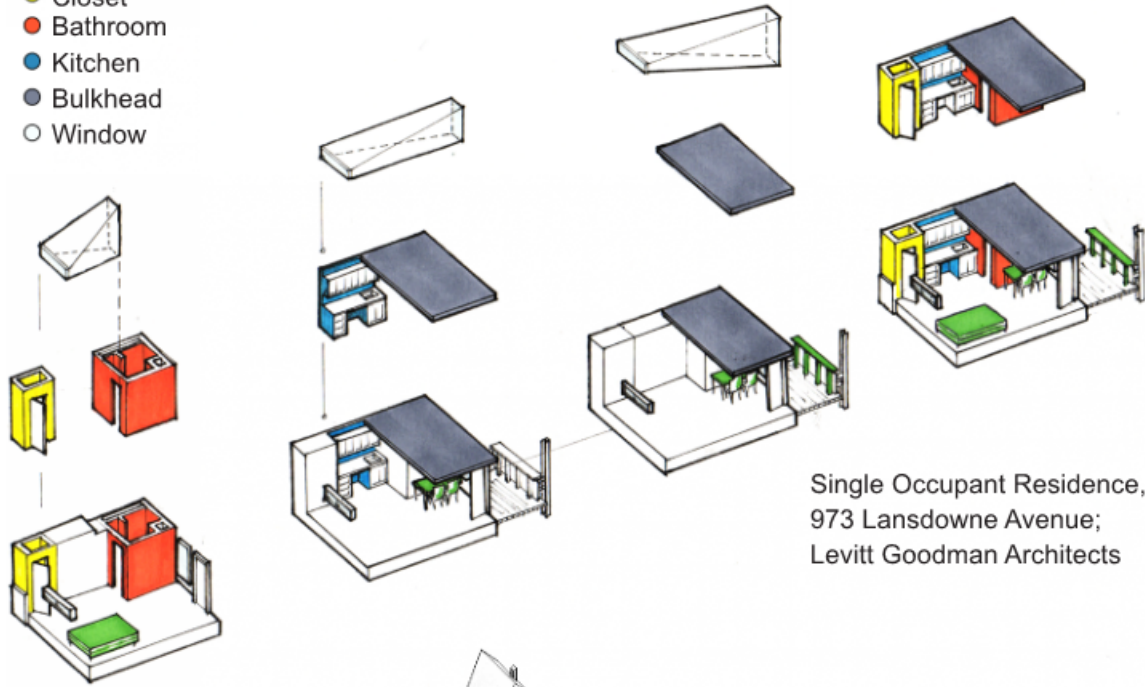

Single Occupant Residence,
973 Lansdowne Avenue;
Levitt Goodman Architects

Industrial Hemp provides enough shiv for 106 DOR Residence's annually, as 2 crops can grow consecutively in the same season.

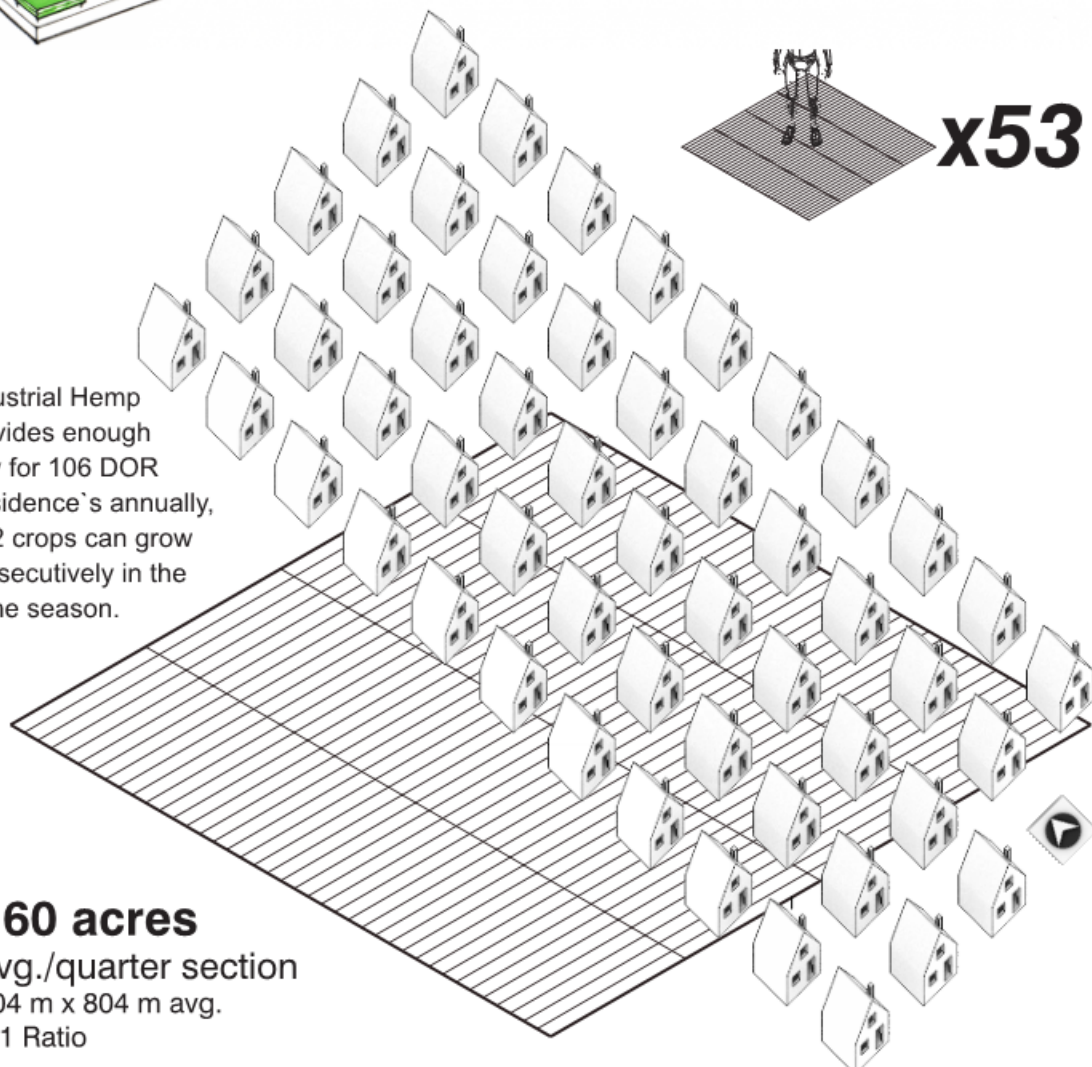

160 acres
avg./quarter section
804 m x 804 m avg.
1:1 Ratio

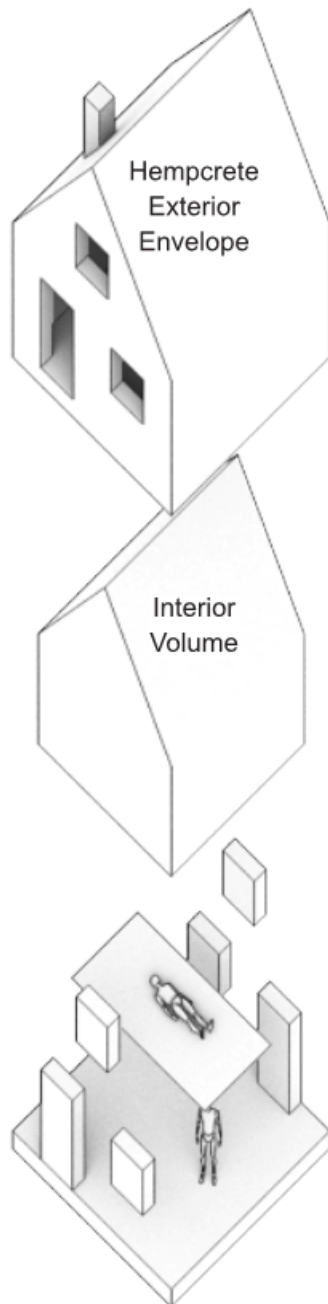

DOR House

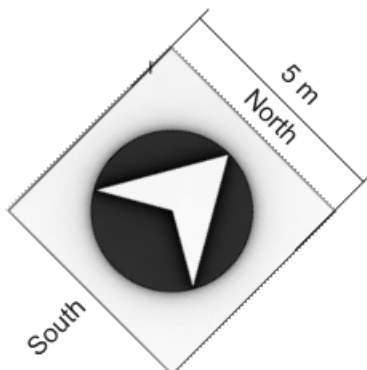

Rural Systems_Social

Whether living in the urban or rural realm, every individual interacts with technology, products, or energy - the social and cultural systems that provide the basis for a modern quality of life. In robust consumer economies an abundance of food, products, and wealth contribute to a desensitization of the latent energy cycles that provide for our base sustenance. This demonstrates a tendency for the individual to overlook the significance of these systems to their lifestyle by only supporting sensationalist, technological experience - the prime example being the touchscreen cellphone. The resolution of the architect in deciphering these systems must be to reveal a symbiotic development of prairie ecological cycles, rural producer initiatives, and the urban consumer experience. Simultaneous exposure is emulated through the peripheral experience that occurs not as a single, linear process, but as broken and sequenced upon the modern concept of transportation and circulation. Energy, food, community and process are exposed to the consumer, intermittently spaced between urban settlements and productive rural surfaces.

As demonstrated by the rural process, producers instigate the agricultural process from a homestead and travel to sites within the rural landscape to plant and harvest agricultural products. When those products are retained or directly utilized on site, the cyclical process of agriculture can be expressly visualized by travelling consumers. In this sense, architecture retains a physical manifestation of the Hemp plants domestic and cultural attributes, lending to the image of vernacular sustainability. When analyzing the application of Hems material abundance, a single

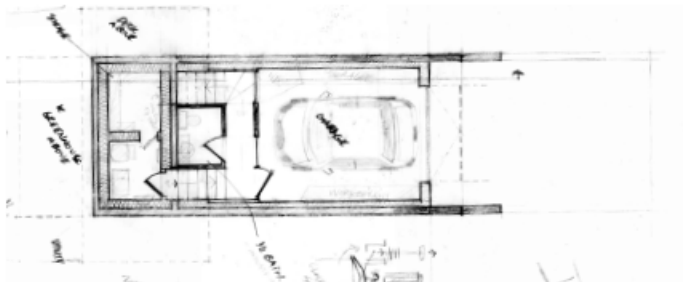

Basement/ Garage Floor Plan

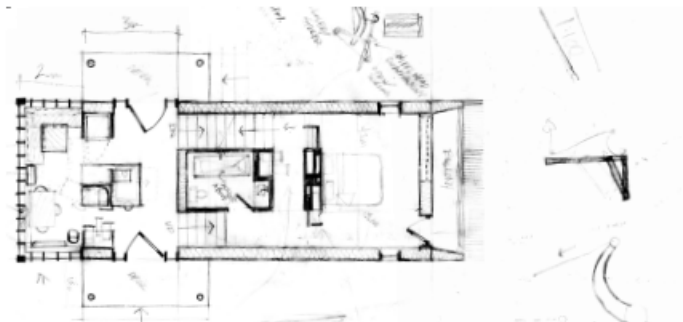

1st Floor Plan

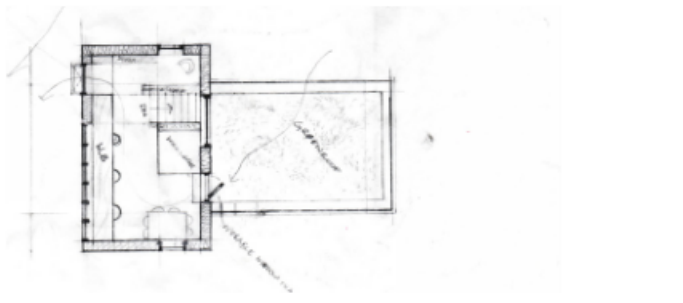

2nd Floor Plan

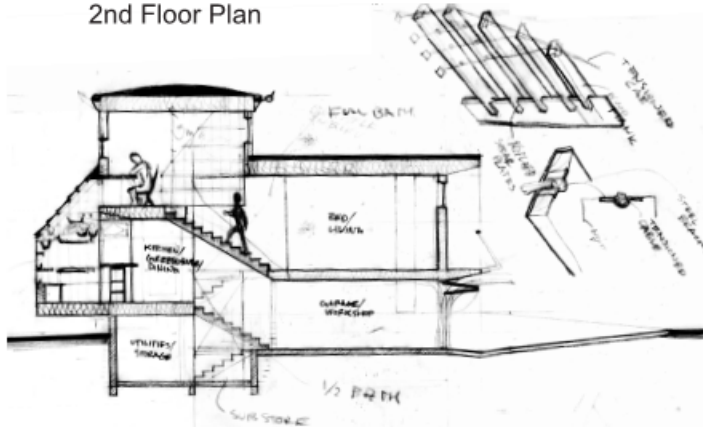

South by North Building Section

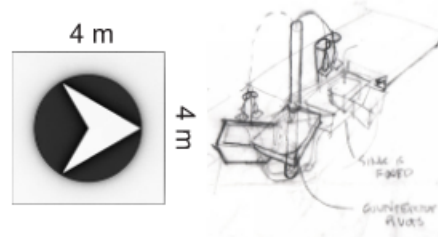

The Studio Residence was a simple design iteration which attempted to evolve the DOR residence into a more comprehensive rural lifestyle. Services are anchored in the ground and basement, accessed from the garage/ workspace, also set below grade. To initiate response to landscape, the foundation is imprinted and buried into the productive surface.

Covered twin decks flank the east and west entrances of the kitchen, acting as exterior rooms onto rising and setting suns. A greenhouse opens the kitchen to the south prairie vista, projected as inhabitable bay window and living wall. Accessing the kitchen through the garage, inhabitants may continue up a staircase that encapsulates the bathroom/ rest service core. Set above the garage, the master bedroom/ sleep opens to the northern sky and northern lights, viewed from an enclosed balcony.

Above the kitchen and flanking decks, procession concludes in the studio/ work space that overlooks the prairie landscape - muse to the rural designer.

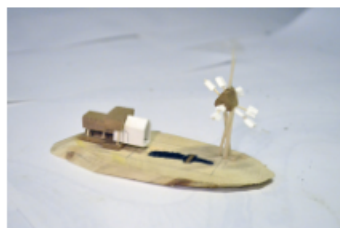

SW, South, and SE perspectives of Studio Residence, dugout, and RE-Tower.

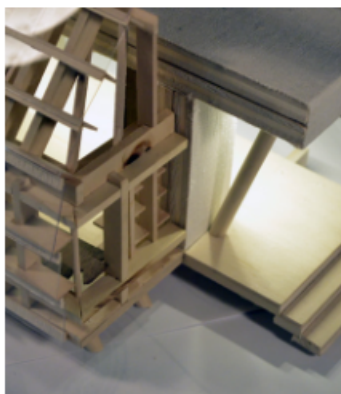

Kitchen/Greenhouse model demonstrating connections to the Hempcrete walls and rural landscape.



Intended to seamlessly connect interior to exterior spaces, the kitchen/greenhouse provides a living, productive wall for residents to develop food resiliency.



quarter section will produce enough Hemp shiv for 53 DOR Residences. The DOR Residence is modeled after the SRO Residence designed by Levitt Goodman Architects of Toronto, Canada.¹⁰³

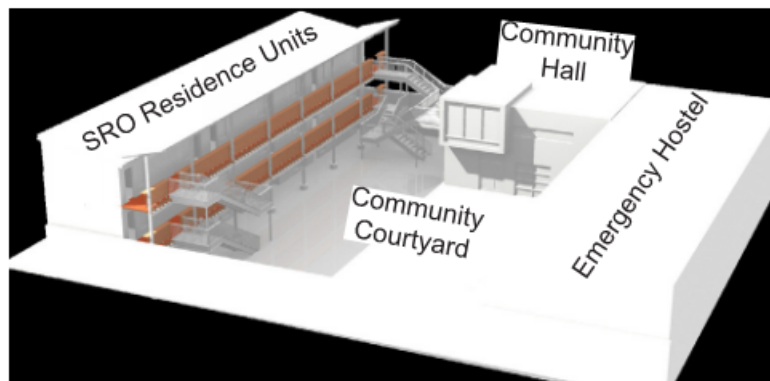

973 Lansdowne Avenue, Toronto Canada, Levitt Goodman Architects

SRO units offer private dwellings to men undergoing transitions in their life where community outreach is necessary. A heavy wall protects tenants from the street, lightly punctured by narrow windows for prospect and privacy. Large entry doors and windows open onto widened galleries functioning as communal ‘gathering’ spaces. Made from steel I-beams and exposed wood framing, galleries are roofed and open onto the garden courtyard. A clear articulation of materials is used to translate the industrial nature of the courtyard and urban realm into the institution and dwelling. A concern of LGA projects is a well versed material culture intended to expose residents to a higher standard of living.

The DOR house is developed for the same reasons as the SRO unit, except double occupant residences are

103.LGA Architectural Partners. “973 Lansdowne Avenue.” Last modified June 20, 2016. <http://lga-ap.com/project/residential/lansdowne>

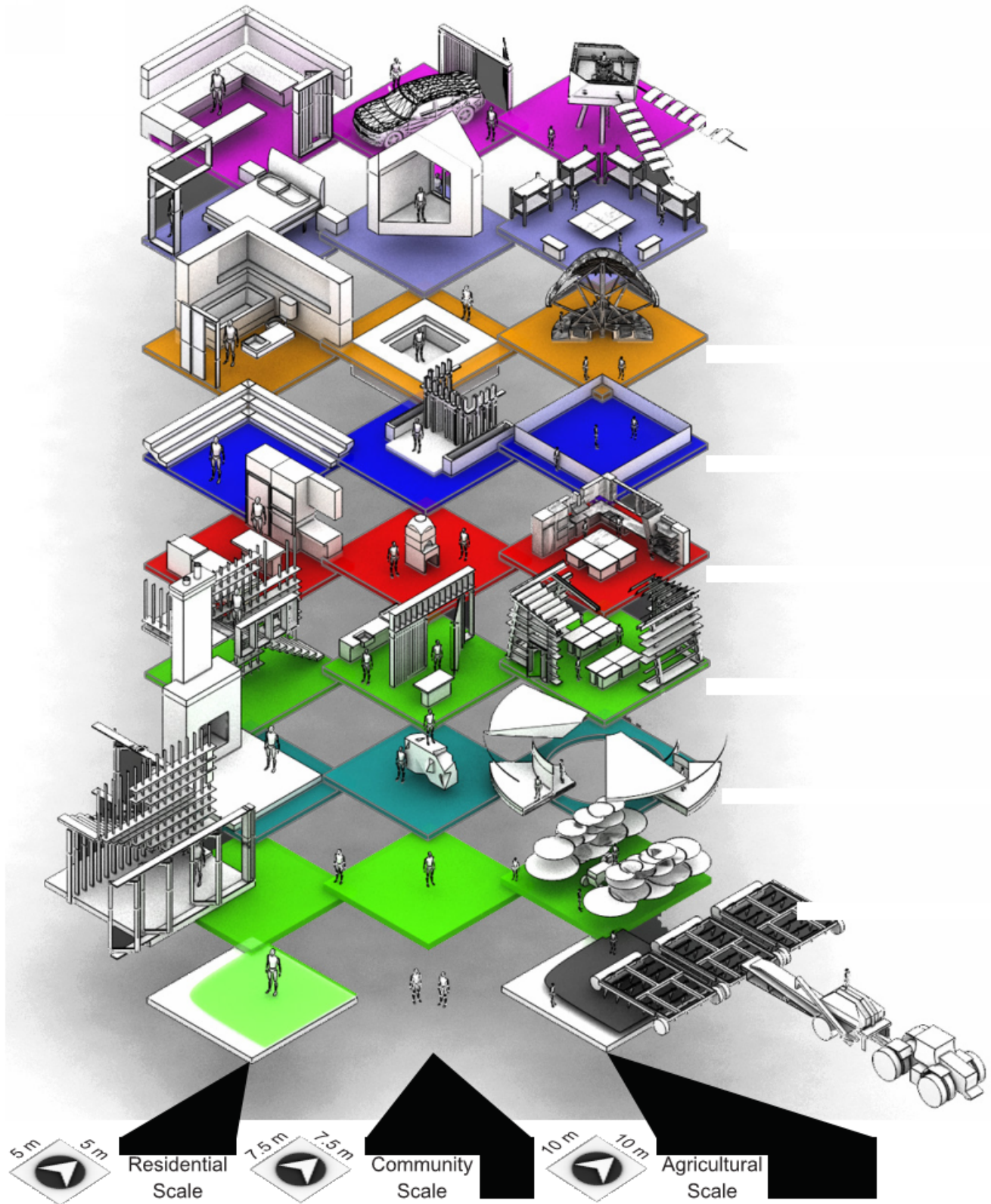

The vastness of the prairie grid and the industrial agricultural machine affords architectural design an economy of scales to interpret and reimagine. Working between the ideas of Residential/ Live, and Industrial/ Work, the scale of Community/ Play is resolution of two socio-technical extremes.

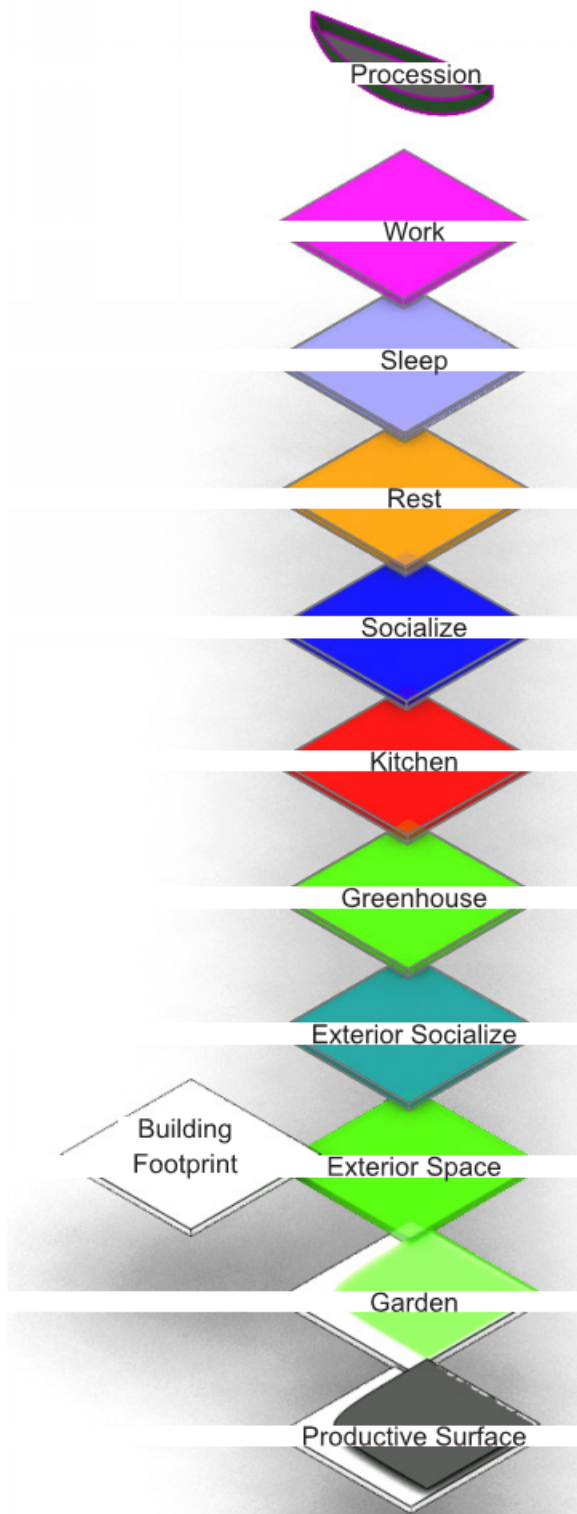

Sustainable Rural Community
Program Typology Legend

intended for urban consumers that want to transition to a rural lifestyle through built form. Provision of a single room with bath and sleeping loft, a DOR house provides the basic necessities for living in the rural landscape, and is intended as the threshold structure to urban integration - a low cost, small footprint, low energy house. More so, the DOR house is the first design iteration that architects must consider when designing rural lifestyles, in that every room must participate in the rural process, or, encapsulate the entire process in one room. With generational farmhouses, iterations of family lifestyle are manifested through the addition, subtraction, and reprogramming of space. As such, architectural design stems from the program of each room towards a sustainable agricultural process - the economy of scale between residential, community, and industrial space.

Ultimately, buildings represent social systems within the rural landscape and should engender inhabitants towards sustainable modes of living. As the most basic rendering of the rural lifestyle, DOR houses can be reproduced quickly and in great quantities at low costs. When considering the factors delimiting a quality architecture for all, a question posed by the Aesthetics of Number design theory, it is possible to consider Hempcrete and the Hemp plant as an effective solution to Van Eyck's query. Social architecture must reimagine what technology appears as, and not reduce technological development to machines alone. Instead, it is clear that social development must embrace environment and process simultaneously to properly entrench values for community resiliency. Through the threshold of the generational farmhouse and the effort of the producing/consuming individual, sustainable agriculture

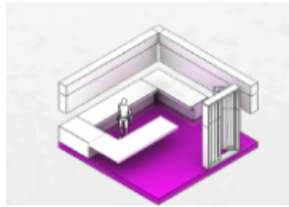

Home Office



Workshop



Renewable Energy



Open -- Closed



Individual -- Collective

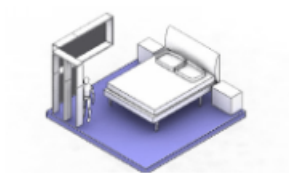

Bed Room



Private Studio



Bunkhouse

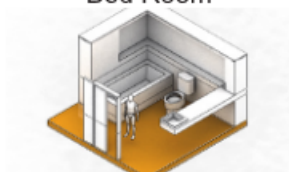

Bath Room

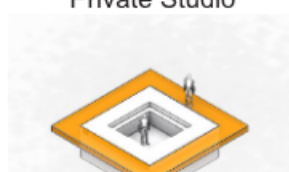

Hot Tub



Pumphouse



Motion -- Rest



Mass -- Space

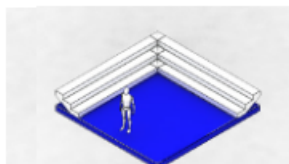

Living Room

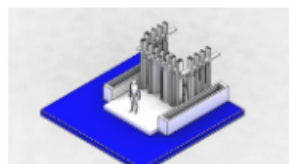

Entrance

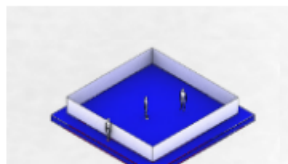

Livestock Pen



Kitchen



Bannock Oven



Commercial Kitchen



Many -- Few



Reimagining the farmhouse program typology to be inclusive of the consumer and the inbetween space which supports the rural producers process.

and community are made whole.

Retting_Cultural

Urban residency is concentrated and demographically diverse, requiring large inputs of energy and food to maintain a standard quality of life. Rural residency is sparse, utilizing natural space to produce quantitative urban inputs. As farms produce food for cities, cities produce products and unique social experiences for rural residents, presenting a symbiotic relationship. Warwick, Alberta is closely tied to the town of Vegreville, in that many of Warwick's residents now depend upon the town for the very basic amenities that all individuals require such as food, social and cultural venues, and emergency services. As such, centralization of basic community services delimits the producers process and restricts new rural developments to abide by bureaucratic urban development practices. This trend represents the direct social, economic, environmental, and cultural desensitization of rural lifestyle that can be surmised by the peripheral experience.

In real communities, labours and tasks are shared amongst those that can still perform them. In that grandparents may not participate in the agricultural process as they age, they can still participate in the social and cultural predisposition of the offspring and alleviate the efforts of the parent. Thusly, shared labour and risk diminishes overall risk, lending to the viability of generational systems, given that the actors (producers and consumers) believe and depend upon that system. Ideally, the architecture is synonymous with community via the agricultural product. In the case of Hemp, a sustainable and economical building

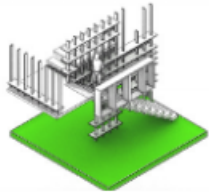

Greenhouse/ Stair



Kitchen/ Greenhouse

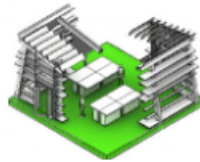

Commercial Greenhouse



Large -- Small



Inside -- Outside

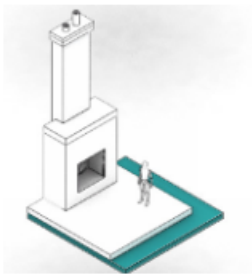

Living Deck



Landscape Features

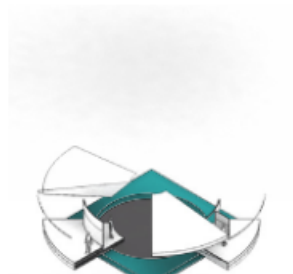

Lookout

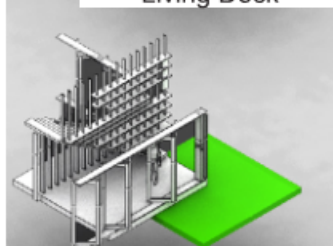

Internal Hall

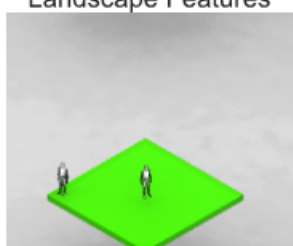

Natural Landscape



Orchard



Change -- Constancy



Part -- Whole



Family

Individual

Community

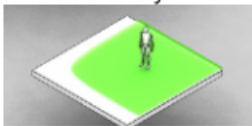

Farmstead Garden



Producer/ Consumer

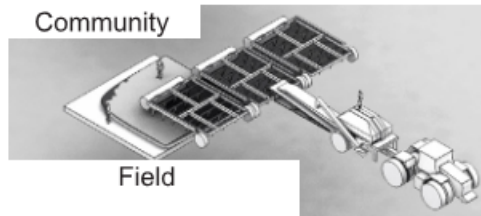

Field



Unity -- Diversity



Reimagining the farm site program typology to be inclusive of the consumer and the inbetween space which supports the rural communities process.

alternative, standing Hempcrete walls become the testament of how buildings become sustainably developed and locally produced. Over time, hydraulic lime cement petrifies the Hemp shiv into limestone, and the generational farmhouse, the barn module and the community hall manifest resiliency of form and process.

Having revealed the mosaic of socio-technical systems composing the Alberta prairies, the architect-planner-entrepreneur can reimagine sustainable rural communities. As such, designing across multiple scales will allow the architect to design between antonyms and the idea that producers and consumers are separate idealisms. By selecting opportunities where the individual intersects rural lifestyle, landscape, and built form simultaneously, the agricultural process can be fully realized across space and time. Where cultural systems intersect environmental, economic, and social systems is not limited to one building program or experience, but is the assemblage and repetition of many moments and sensations. Fear and courage, love and hate, close and far, the human spirit is not one purpose but many, and demands a surface, an environment, and a community to engage a value-add process.



Greenroof

- 4" min. Green Roof Buildup
- Root Barrier
- Drainage Board
- SBS Roofing Membrane
- 1" T&G Wood Fibre Sarking Board
- 1" x 2" Horizontal and Vertical Wood Battens, maintain 2" airspace
- 16" Engineered Open Web Wood Joist @ 24" o.c.
- 12" Hempcrete Ceiling Fill, **R25**
- 2" x 2" SPF Wood Noggins
- 3/4" Wood Wool Board

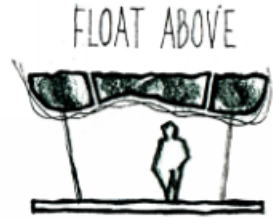

Hempcrete Ceiling
SIP

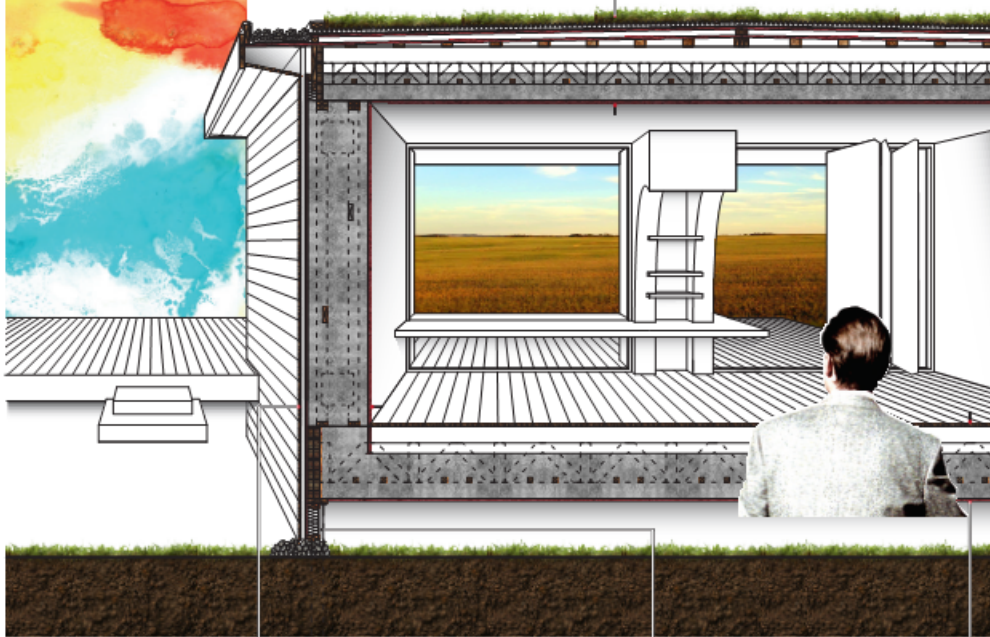

Hempcrete Wall
SIP

- Horizontal Tight Fitting Shiplap Wood Cladding
- 1" x 2" Vertical Battens, maintain 1" airspace
- 3/4" Wood Wool Board, both sides
- 16" Hempcrete Wall Fill, **R33, .458 MPa**
- Shear Wall - Double 2x4 Wood Framing @ 16" o.c. w/ 3/4" OSB shearplate
- 3/4" Wood Wool Board

Hempcrete Floor
SIP

- 3/4" Hardwood Plank Flooring
- 1" x 6" Diagonal Wood Planking
- 16" Engineered Open Web Wood Joist @ 24" o.c.
- 12" Hempcrete Floor Infill, **R25**
- 2" x 2" SPF Wood Noggins
- 3/4" Wood Wool Board

Foundation & Skirting Wall

- Engineered Steel Screw Pile
- 12'-0" min. depth
- 3/4" Wood Wool Board, both sides
- 2x6 Stud Wall @ 16" o.c.
- R-20 Hempwool Batt Insulation
- Cleaned Crushed Gravel piled 3" above base of Skirting wall

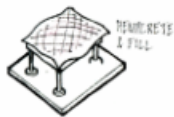

Hempcrete Typology #1_
Space Frame On Stilts

Section 2: The Seed Building

To simplify the agricultural process and its foundations through the generational family farming process is a significant task, but is necessary to conveying the essence of rural landscapes to urban consumers. What is understood of rural communities and agricultural producers is that they develop building typologies that respond to commonly expressed needs. Given the rise of mail-order buildings which helped populate rural Alberta, vernacular built form was imported from factories that employed urban workers. The concept that modern farms require anything more is not an economical decision, but tied to the environmental, social, and cultural criticisms of the rural producer. In developing new building typologies, the rural producers need for a sustainable agricultural practice is confirmed and associated directly to the rural landscape. Having explored the idea of procession through rural landscapes and the concept of the peripheral experience, new architectural form is given to the agricultural process - referred to as the seed building.

As producers introduce sustainability to the rural landscape via the seed building, consumers are exposed to a reimagined productive surface. The concept of the



Hempcrete - Hand Mixed

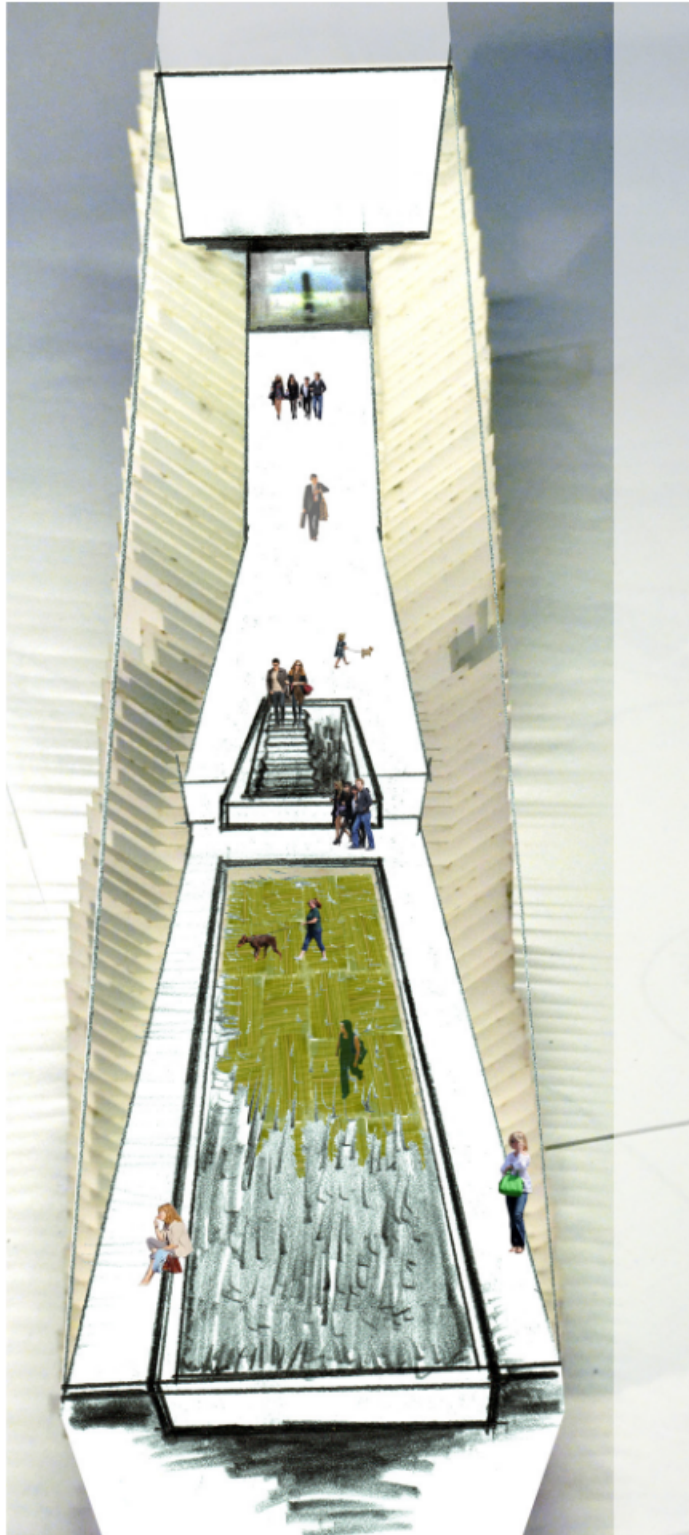

Concept models for the barn module roof and consumer tube through granary.



Anticipating the reimagined rural experience concludes the analysis of the existing industrial agricultural landscape. What a sustainable rural community requires are intensely personal moments where multiple facets of an agricultural process align into a single sensationalist impression.

seed building is simple - that building program, form, and material respond to the economic, environmental, social, and cultural needs of rural producers. Given that rural producers incorporate various systems of production into their agricultural process, architecture stands to influence a broader range of sustainable practices. When the architectural form begins to symbolize a greater social and cultural response to preserving our productive landscape, then consumers are subconsciously confronted by resilient community processes. When those processes positively influence the lifestyles of consumers and producers alike, fulfilling multiple roles, then that process is catalyzed as the appropriate response to the inhabitation of the prairie landscape. More than ever, the agricultural process must become sustainable to preserve the home and homesteads that make Alberta a unique Canadian experience.

Seed buildings are intended to fulfill the Live/Work/Play modes of rural lifestyle - iterations for the generational family farm that respond to producer needs for energy, skill building, value-add process development and environmental rehabilitation. As residential, commercial, and industrial scales of building demand specific design responses, but must resound from the human scale, the seed buildings fulfill the in-between space of urban to rural. As Hemp and Hempcrete buildings begin to signify resilient community development in the rural landscape, consumers may begin to implement similar processes into urban lifestyles. More so, the Seed building is intended as a built manifestation of a rural system exposing its simplicity to consumers and producer offspring alike. When seen as a reproducible process and product, dissemination of practice is imminent.

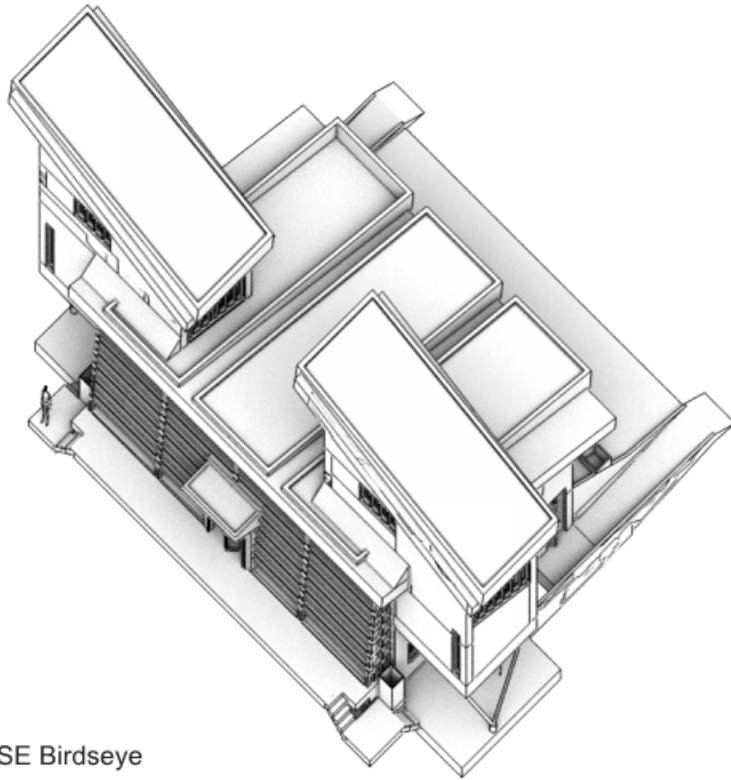

Occupants: 3 - 4

Floor Area: 200 m²

Hempcrete Building Envelope: 450 m³

Estimated Cost of Hempcrete: \$ 52780

SE Birdseye Axonometric

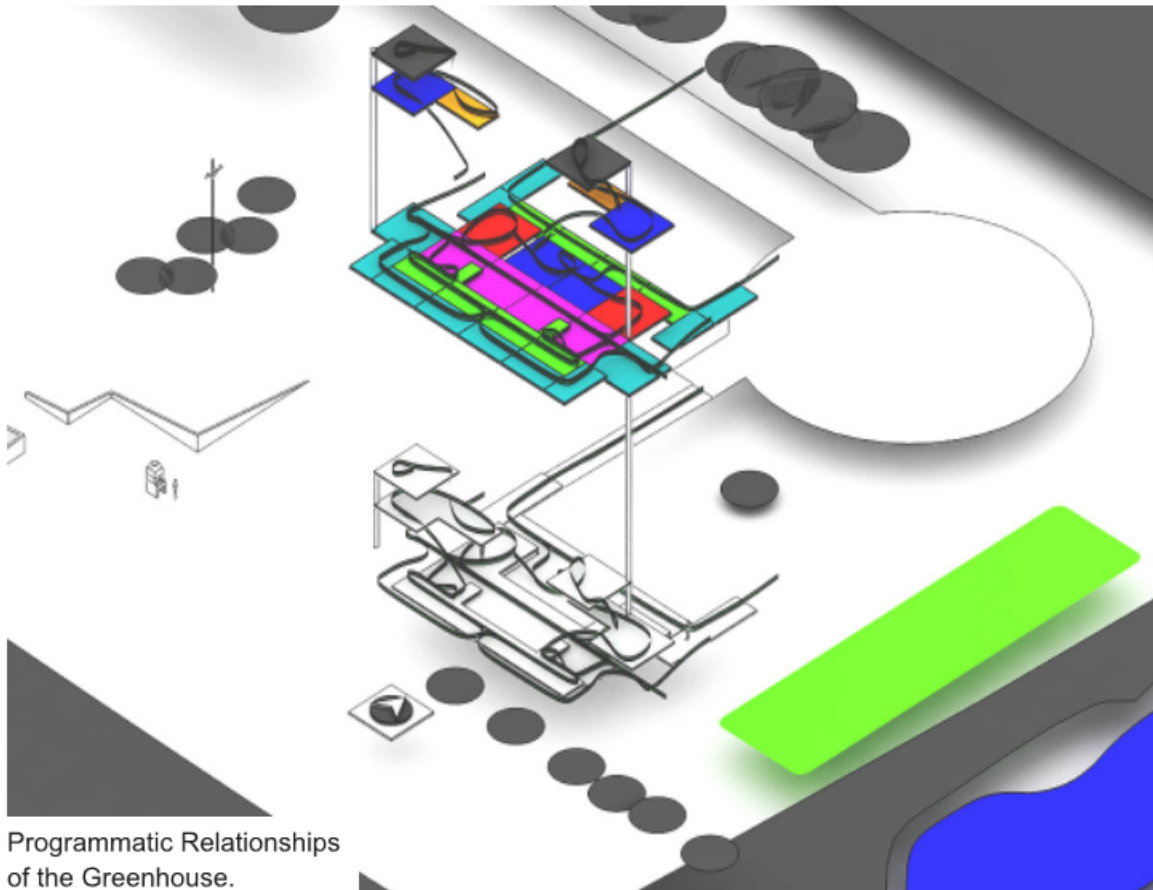

Programmatic Relationships of the Greenhouse.



Kitchen/ Greenhouse

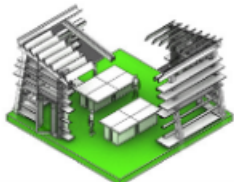

Commercial Greenhouse

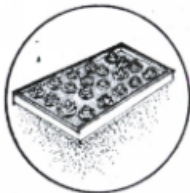

0m

5m

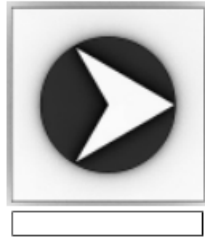

Food_Kitchen Greenhouse

Programming the Greenhouse requires direct integration into established methods of resilient food production. By sequencing the occupants procession to the daily producer cycle, seasons are more apparent to the start-of-day and end-of-day routine. The Southern wall acts as living wall, providing continuous shelving for hydroponic gardening, doubly acting as solar shield to prevent interior overheating. By designing half of the building and mirroring the plan, builders reduce construction times through repeatable construction detailing. Simplifying the food process to immediately benefit the rural producer strengthens the resilient generational farming process. Above all else, the Greenhouse allows new rural producers to pool resource, effort, and knowledge into establishing holistic farming process - each helping the other.

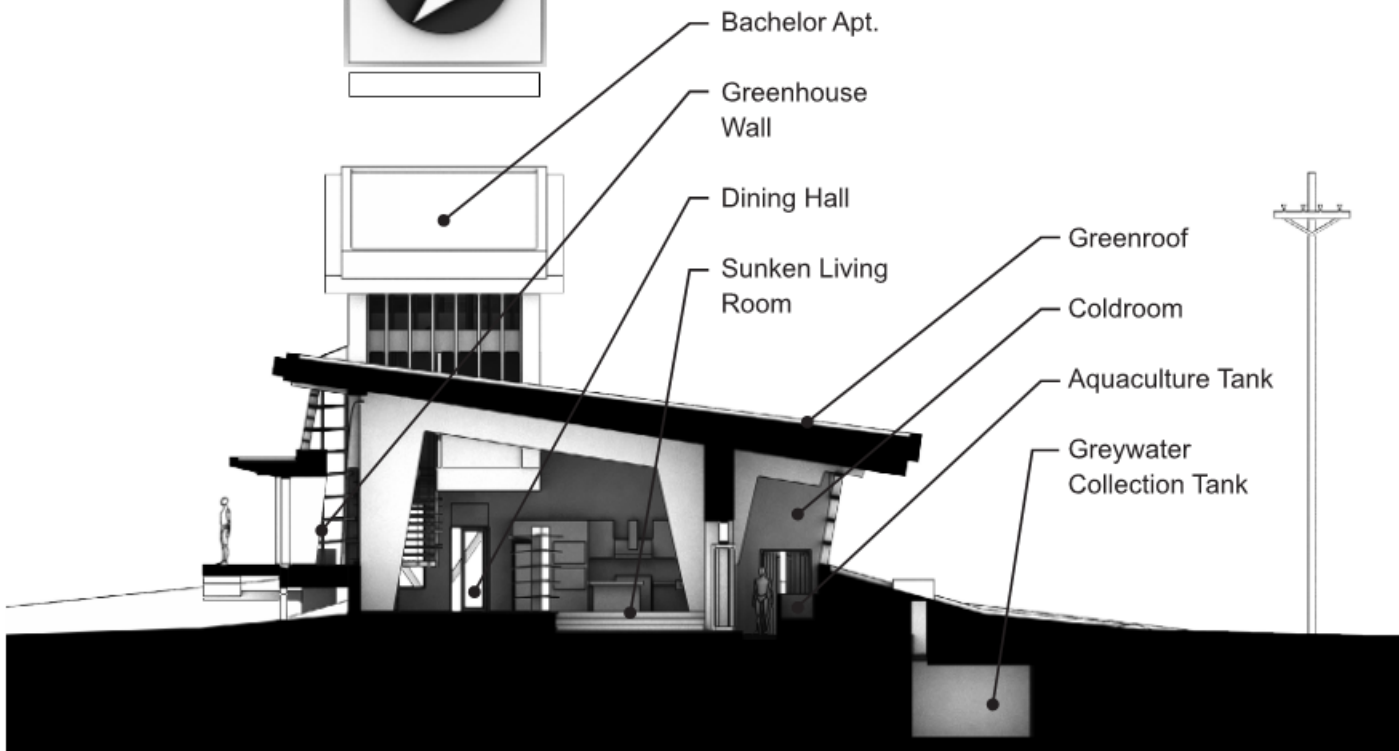

Bachelor Apt.

Greenhouse Wall

Dining Hall

Sunken Living Room

Greenroof

Coldroom

Aquaculture Tank

Greywater Collection Tank

South by North Building Section

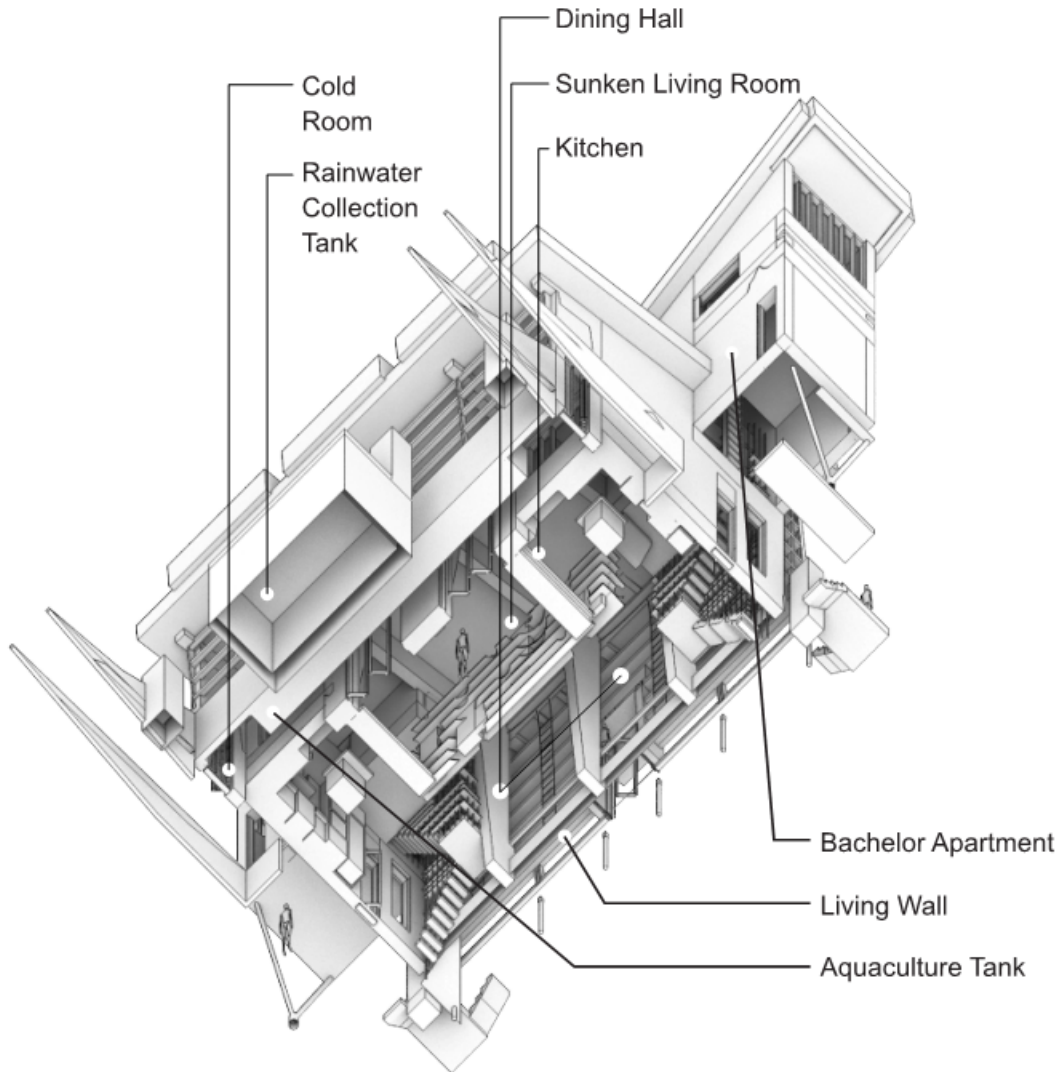

NW Wormseye
Axonometric

As two Double Occupant Residences cap the Greenhouse, they share a symmetrical assemblage of kitchens, dining hall, sunken living room, cold room aquaculture tank, and living wall.



South Perspective_Greenhouse

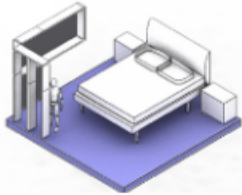

Bed Room

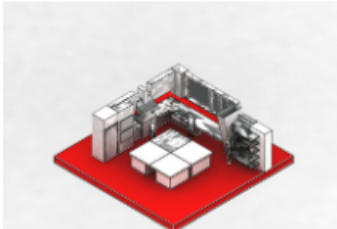

Commercial Kitchen

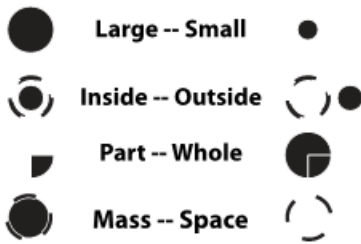

The concept of the Greenhouse is to allow producers year round cultivation of organic food products and aquaculture. Intended as a proto-social building program, the Greenhouse makes producers food resilient through a holistic food growth, harvest, preparation, and sharing process within the home. As the grandparent and parent would teach the process of a farmstead garden to the offspring, the greenhouse will afford the rural producer a venue to demonstrate food resiliency to the urban consumer. The Greenhouse utilizes a flat-sloped greenroof to collect runoff for an integrated greywater system, cycled back to the living wall for food production. Raising the Double Occupant Residences to above the main hall provides vistas onto rural process from the occupants bedrooms and private social space/office.

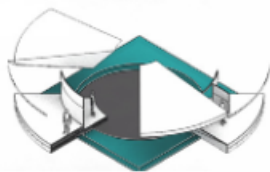

Lookout

Family



Farmstead Garden

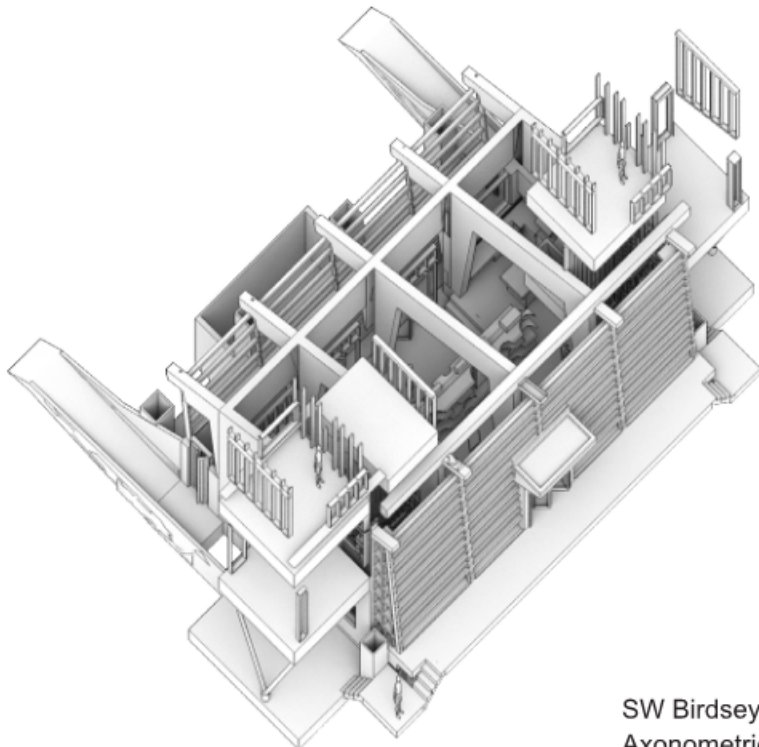
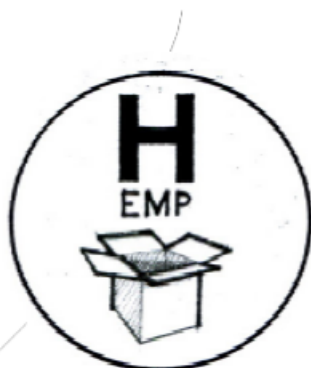

SW Birdseye
Axonometric

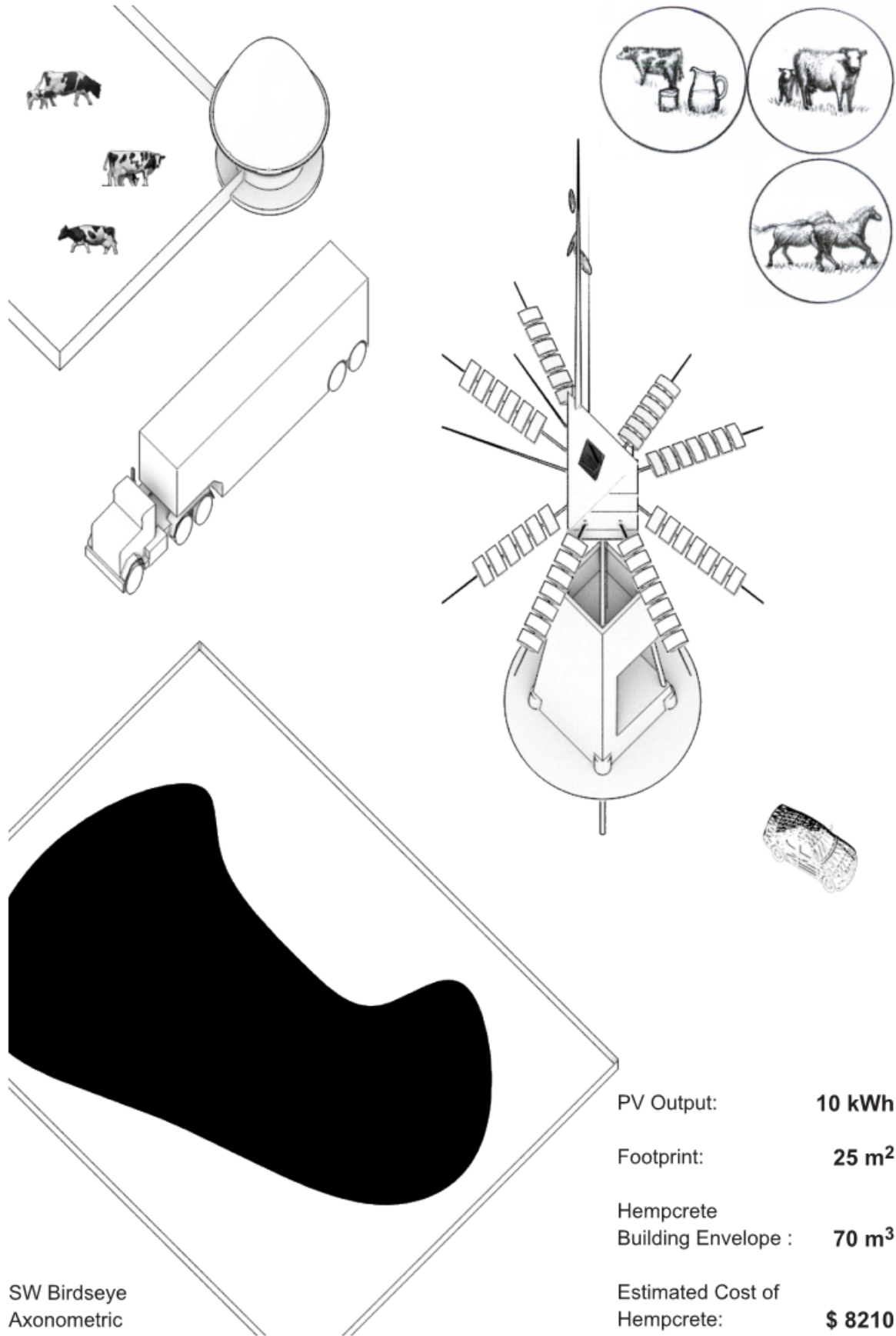

SW Birdseye
Axonometric

PV Output:	10 kWh
Footprint:	25 m²
Hempcrete Building Envelope :	70 m³
Estimated Cost of Hempcrete:	\$ 8210



Renewable Energy

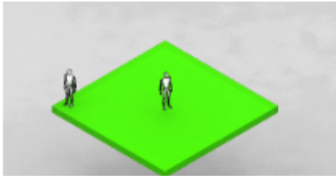

Natural Landscape

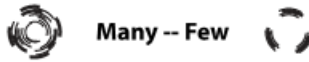

Many -- Few



Bunkhouse

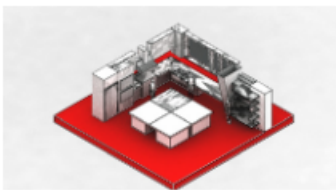

Commercial Kitchen



Workshop

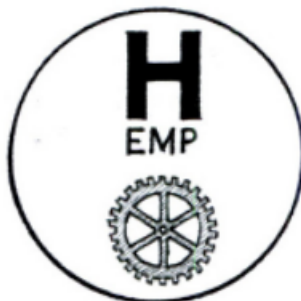

Energy_RE-Tower

Inspired by Alberta's ruthless development of non-renewable energies and its necessity to the established agricultural process, of the industrial agricultural The RE-Tower and Pumphouse are intended to alleviate the rural producers dependence to the energy grid. Autonomous power generation allows farmsteads to grow everywhere, providing energy for environmental reclamation and value-add processing anywhere it is needed. Access to renewable energies allows rural producers to focus on the agricultural process and the sustainable cultivation of resilient communities without concern for energy consumption. Biomimicry led design to create a polar array of PV panels in the fashion of radiating tree branches to increase solar exposure. The functions of the RE-Tower were expanded to improve telecommunications in rural landscapes through the addition of satellite masts. This additional height and socio-technical orientation creates rural landmarks to a resilient rural process.

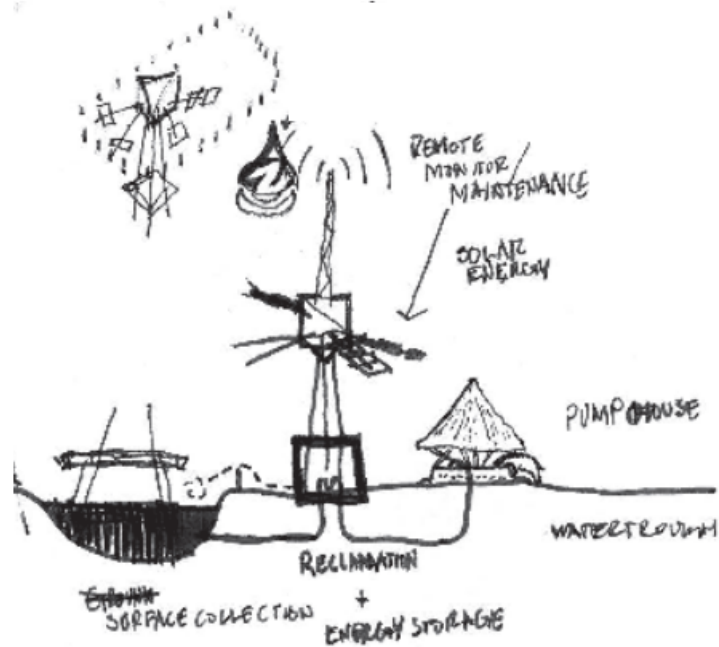

RE-Tower into Rural Systems.



Ground Floor Plan



Pumphouse Ground Floor Plan

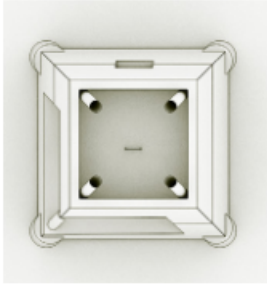

Roof Deck Floor Plan

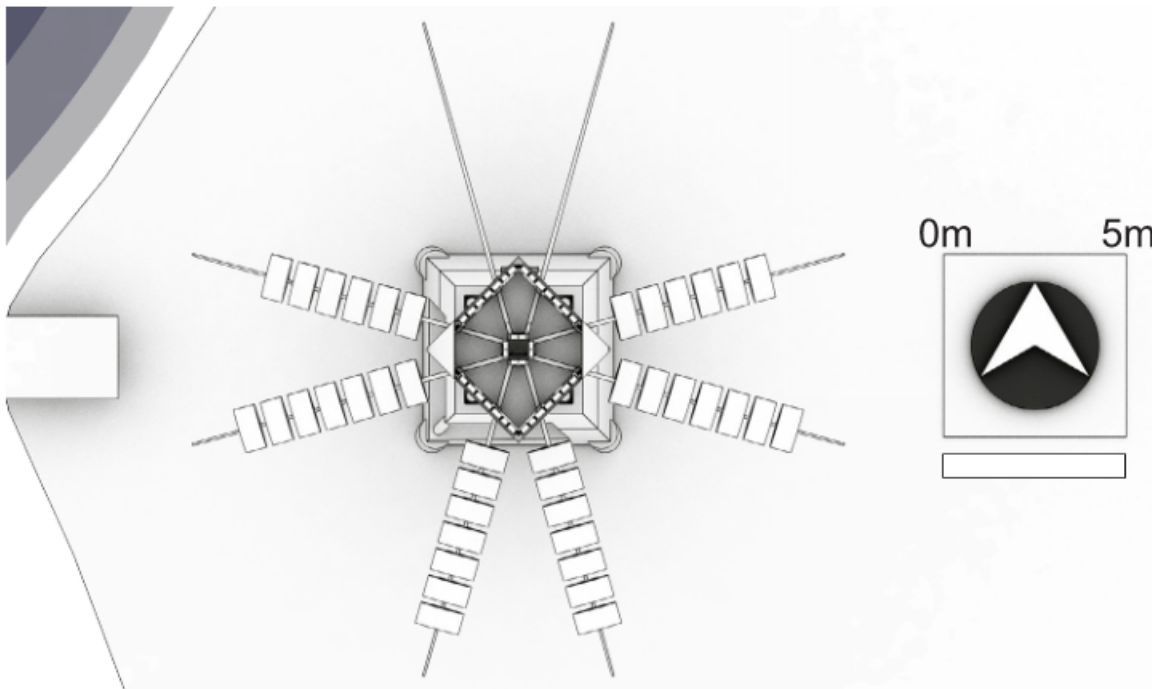

Mast Head Floor Plan

Producers access the mast head through an internal ladder, only accessible from the battery house roof deck. It is important that the RE-Tower is not accessible to random passersby to ensure that vandalism and theft are deterred. A growing issue in rural Alberta is degradation of community and neighbourly spirit as crime infills a devalued rural landscape.

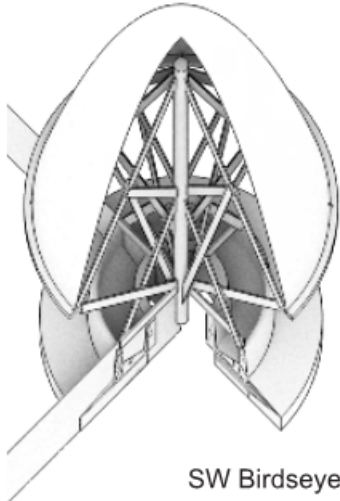

SW Birdseye
Axonometric

The pumphouse utilizes Hemp fabric to create a lightweight shuttering for a Hempcrete roof, shading a transportable concrete water trough.

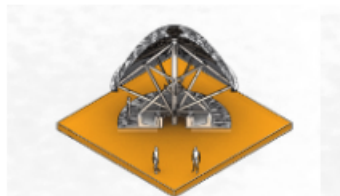

Pumphouse

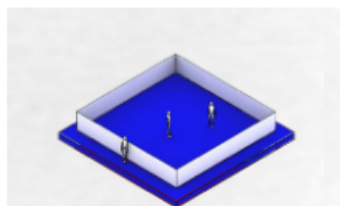
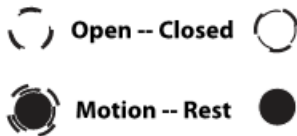

Livestock Pen

Livestock represent a significant draw on fresh water sources. Industrial agriculture threatens rural landscapes by contaminating ecological watering holes.

Construction of the RE-Tower is a sequenced process, first requiring the emplacement of stabilizing concrete foundation piles. Producers are required to source lumber from local timber stands (min. 8" dia. and min. 15m length) to create the four-legged tower. Local welders create a steel mast head that connects the four legs to eight arms (locally sourced timber or aluminum piping), radiating outwards to support the PV panel arrays. The battery house ties the four legs together at ground level and is encased in the Hempcrete envelope to maintain a suitable interior environment for the deep-cycle batteries. PV panels are attached on the basis of producer need.

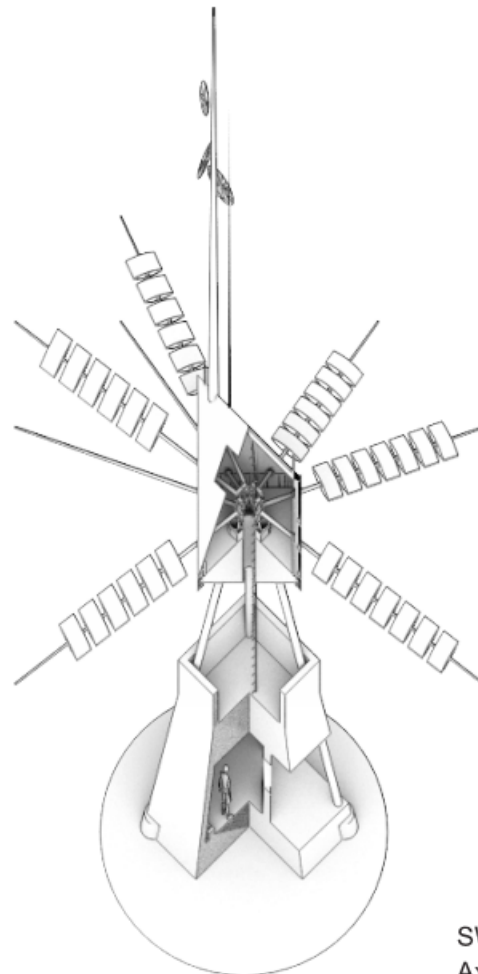

SW Birdseye
Axonometric

268

Livestock
Capacity: **12-16**

Footprint: **200 m²**

Hempcrete
Building Envelope: **250 m³**

Estimated Cost of
Hempcrete: **\$ 29320**

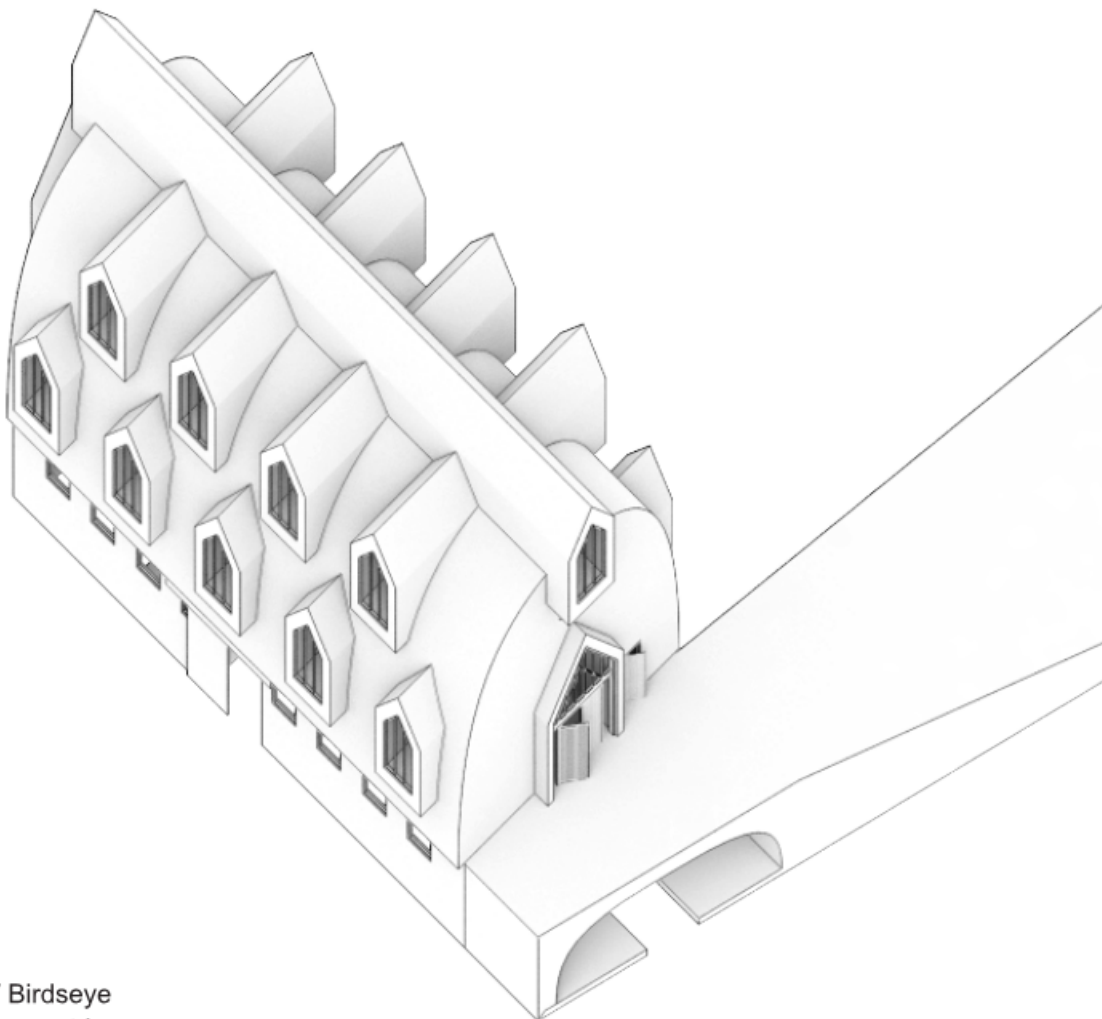

NW Birdseye
Axonometric

Fashioned after the mail-order barns offered through Sears trading Catalogues, the Woodshop Barn is a reincarnation of vernacular building process. As industrial agriculture made traditional barns irrelevant, the open storage above the livestock floor is converted into the farm workshop, where craft skills and value-add process intersect the individual. Dormer windows open an enclosed volume and provide refuge for individuals to overlook the rural landscape.



Garage/ Workshop



Renewable Energy

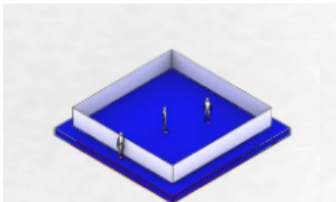

Livestock Pen

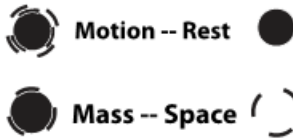

Experience_Barn

The Sears barn catalogue is a remnant of vernacular building culture. By reinterpreting past iterations to modern use, designers and producers alike reclaim the lost art of barn raising. Insulating the loft storage space to create a workshop/studio above the livestock floor expands the functional use of the stereotypical barn. Previously, feedstock was stored above livestock to create an insulative mass and reducing the producers manual efforts - a value-add agricultural process. Alternatively, the open loft space is reimagined as the creative laboratory of the rural producer where they freely develop hand crafted products for personal and community use. Rural producers must not delimit their process to agriculture alone, but should assist in the creation of arts and crafts that mediate the rural lifestyle to the urban consumer. Value-added producers exist in a number of forms and techniques, but most importantly, they require the appropriate space to develop artisanal skills. As such, the Woodshop Barn provides a large interior volume to develop the producers ability to create.

A large ramp allows vehicle access to the second storey workshop programming, doubly serving as a sunken

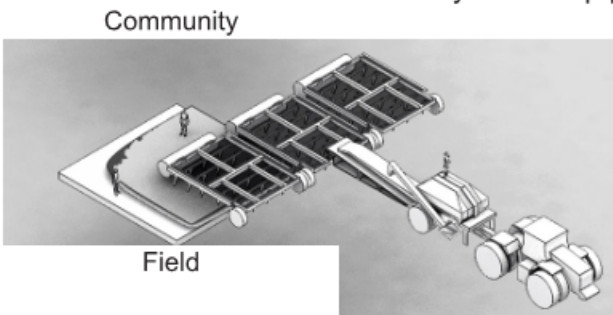

root cellar to naturally cool perishable produce and as a built wind break for the exterior barnyard. Opening the end-gable walls allows for a clear sightline from an interiorized creative process through to the exposed rural landscape for immediate visual connections.

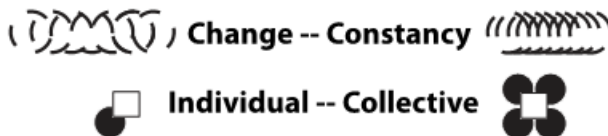

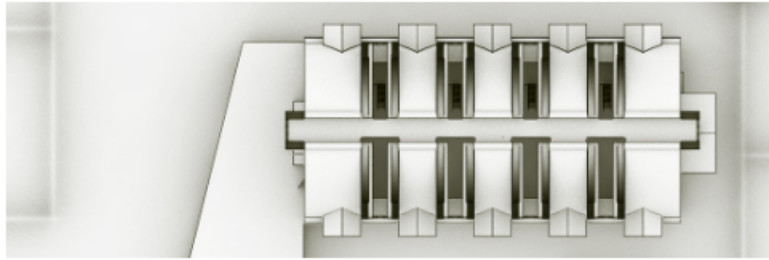

Attic Floor

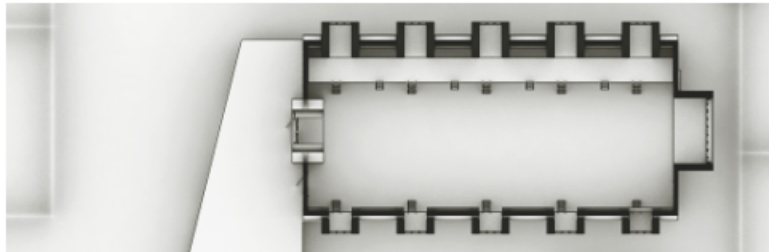

Studio Lofts

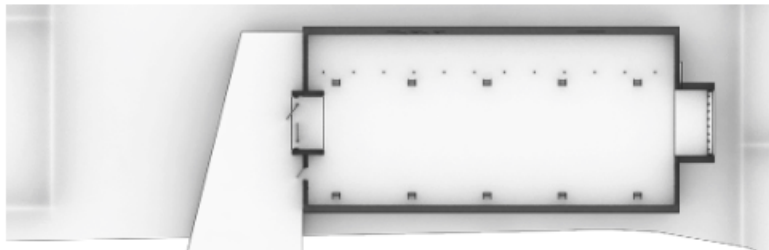

Woodshop Floor

A large ramp allows vehicle access to the second storey workshop programming, and doubly serves as a sunken root cellar to naturally cool agricultural produce. Opening the end-gable walls allows for a clear sightline from the rural landscape through the interior farm process

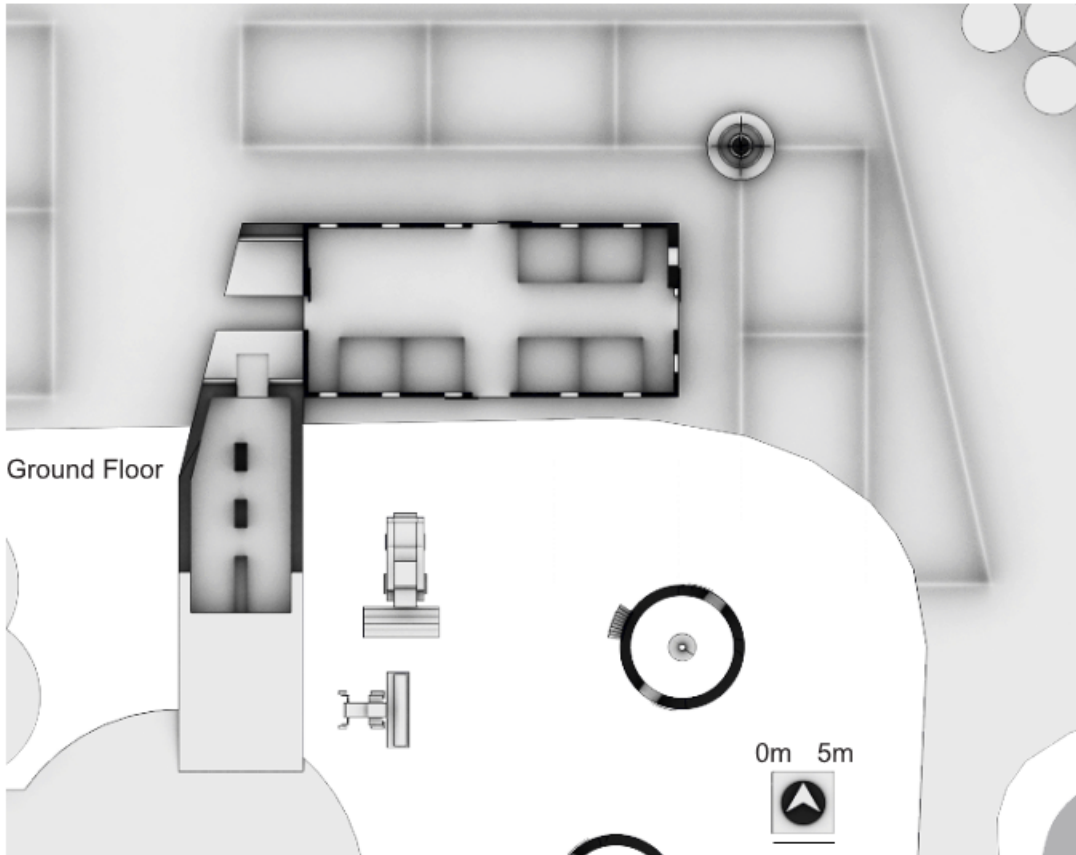

Ground Floor

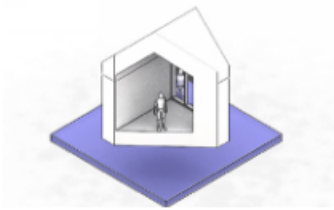

Private Studio

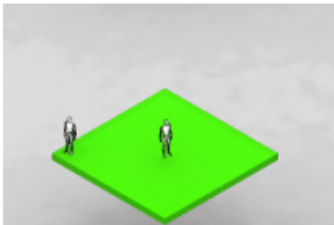
Natural Landscape
Individual

Producer/ Consumer

The Woodshop barn orients its long axis West by East to increase passive solar gain and maximize day lighting. As the dormers project towards the North and South, cool light seamlessly blends with warm light to assist interior ambiance. Inhabitable dormers create quiet alcoves and lighten the barn loft interior whilst expressing a new engagement of rural producer process. The addition of a mezzanine to the North wall of the barn loft extends the social floor plate of the private studio dormers, and creates a removed workspace for the artisanal producer. Integrating livestock, craft building, and creative development space into a single agricultural program extends the associative relationships of local steward to artist.

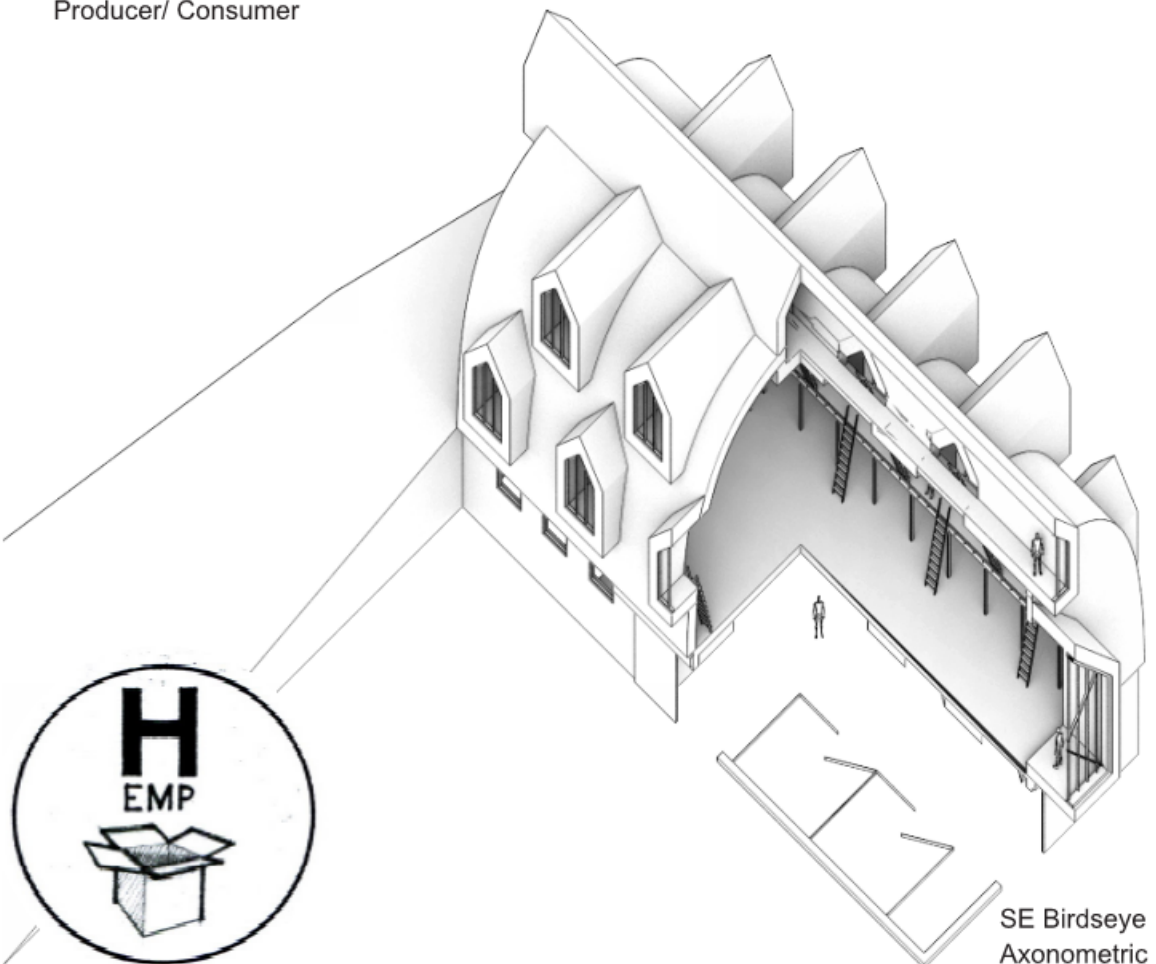
SE Birdseye
Axonometric

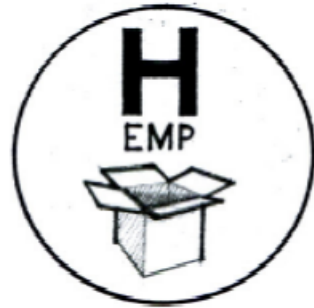
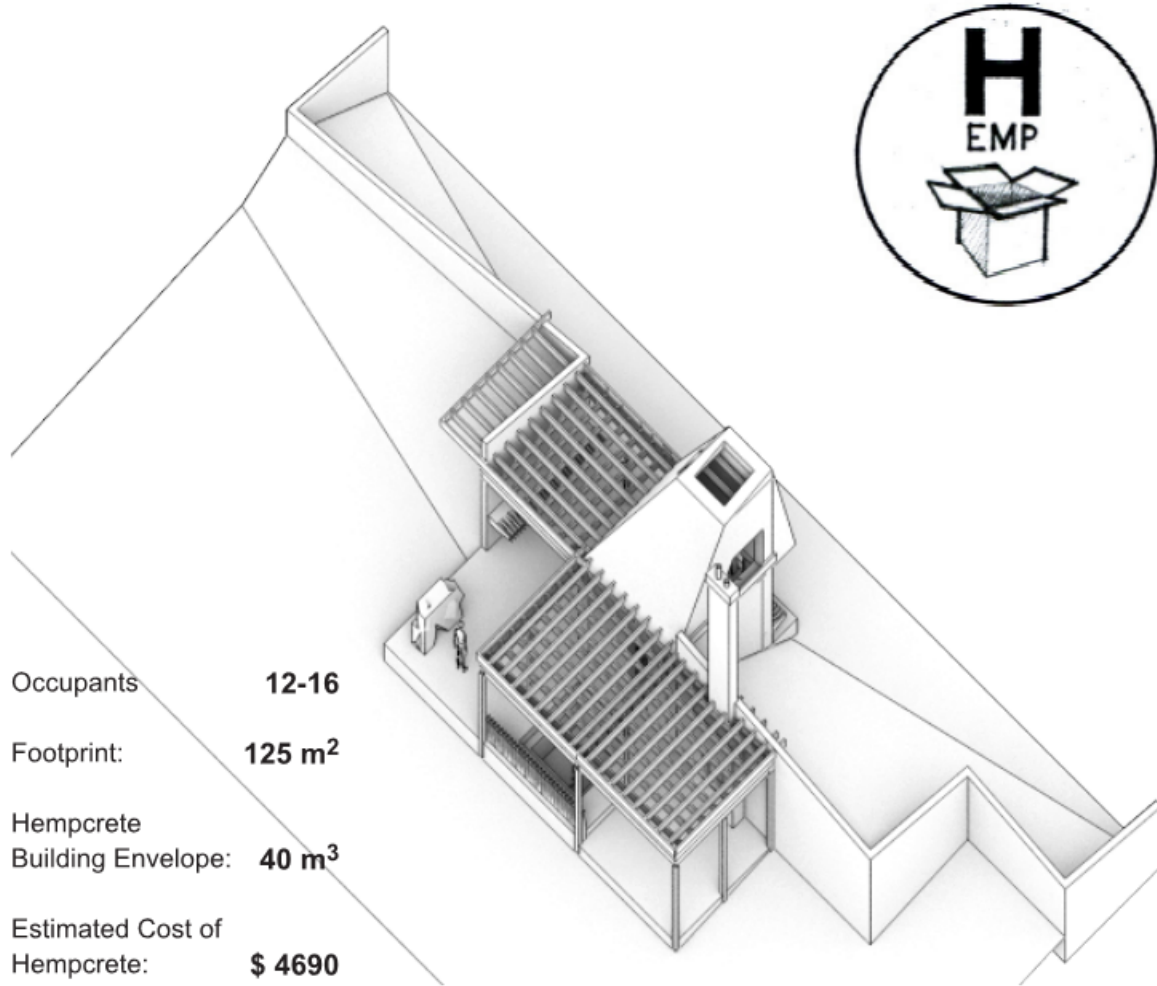

NW Birdseye
Axonometric

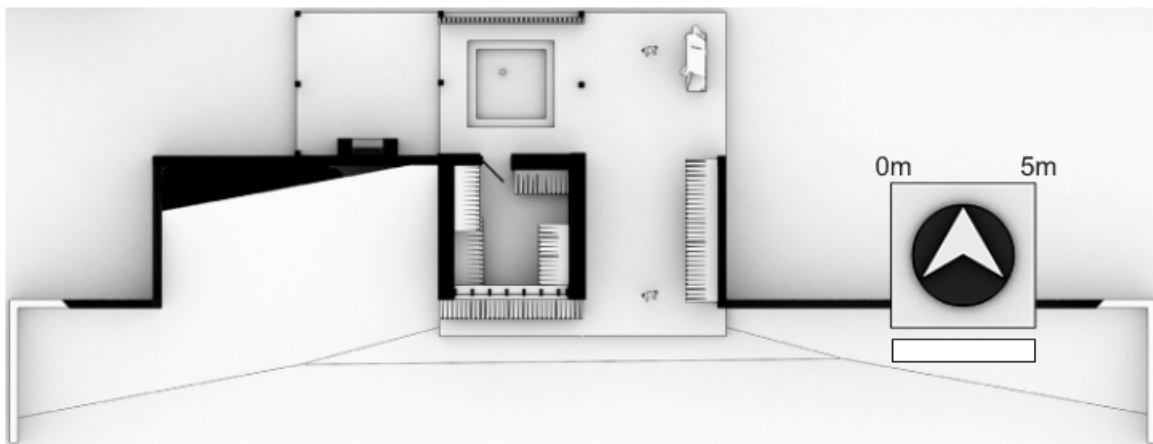

Ground Floor Plan

The Smokehouse incorporates three programmatic elements which coalesce the Live process of the rural producer; a sauna, an outdoor bath and an outdoor living room. This structure is sited to frame portions of the producers farmyard as it intersects the productive rural landscape. As a landscaping element, the Smokehouse serves as Play structure for the rural producer.



Hot Tub

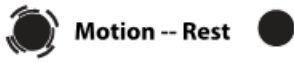

Motion -- Rest

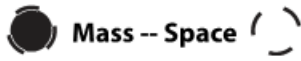

Mass -- Space

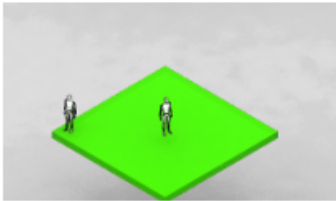

Natural Landscape

Sensation_Smokehouse

Agriculture is a physically demanding process in any form, requiring the producer to create a healthy lifestyle so they may continue to perform manual labour. By creating program and form that assists the relaxation and decanting of the rural producer, the architecture affirms the rural lifestyle as a means of mental, physical, and environmental balance. The Smokehouse consists of a sauna and patio that orient occupant views southwards and upwards to the night sky. Developed on a 5m x 5m grid, program extends outwards to an outdoor hot tub and adjoining patio's that host social activities. Combining the rehabilitating sensations of hot air, hot water, and prairie landscape affords rural producers a direct link to resting in the rural landscape.

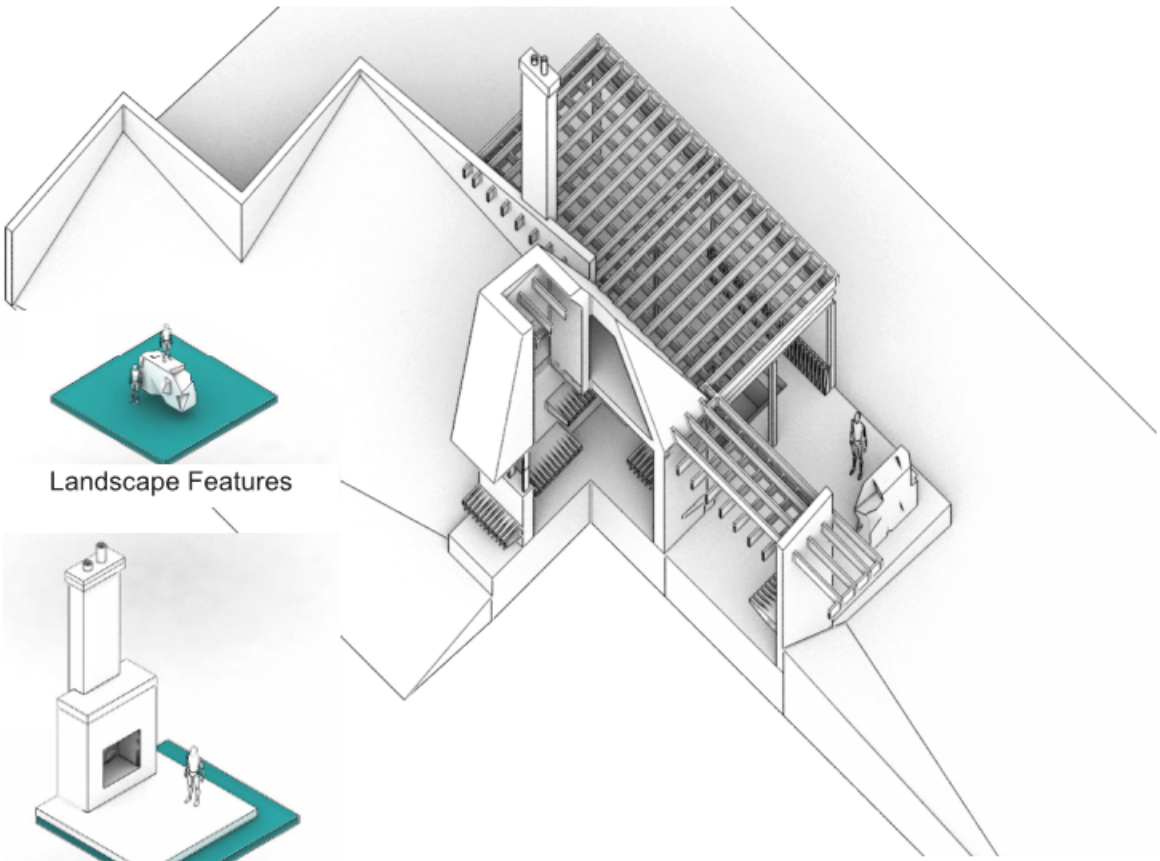

Landscape Features

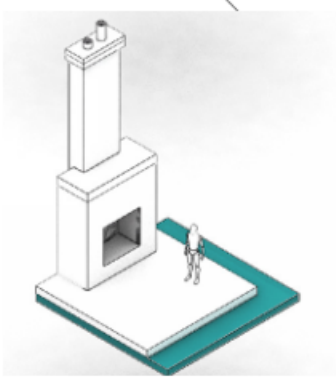

Living Deck

SE Birdseye Axonometric

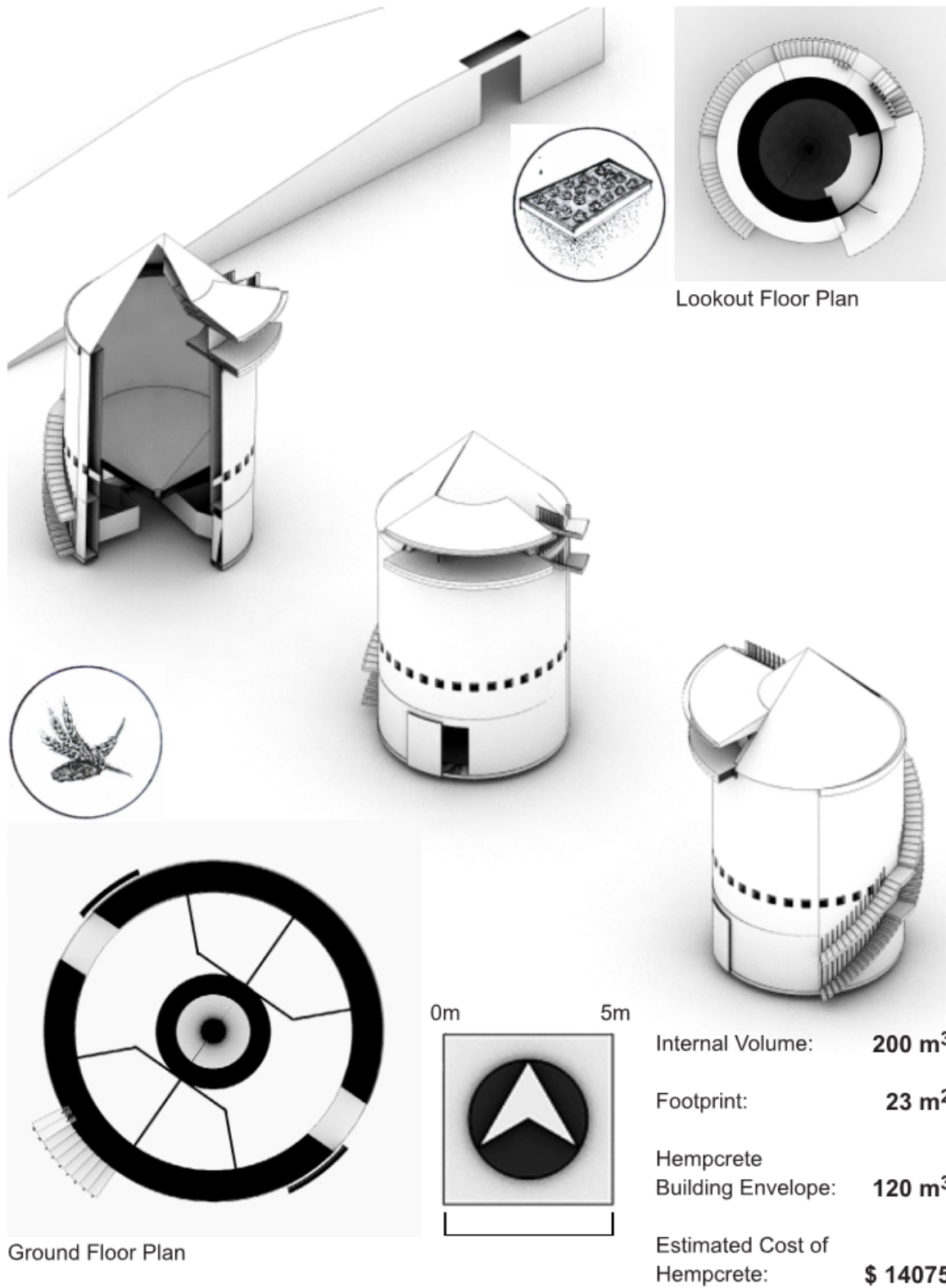

The ground floor of the Granary doubles as a livestock barn given the thermal heat massing properties of cereal grain. A spiral staircase provides a 360 view of the rural landscape as it extends from the farmyard to vantage point over the farm site.

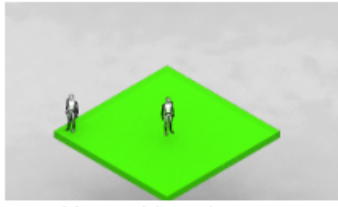

Natural Landscape

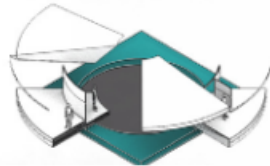

Lookout

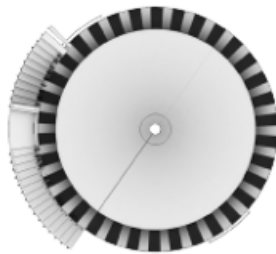

Hopper & Window
Lite Floor Plan

Community

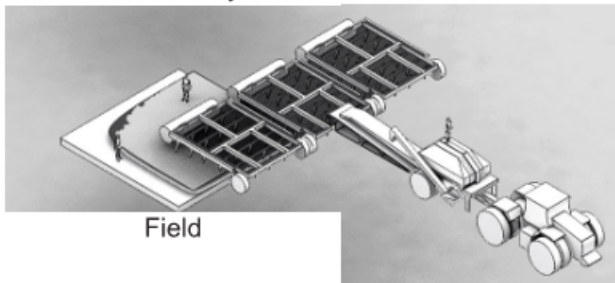

Field

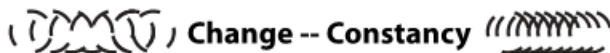

Resilience_Granary

Although the typological steel grain bin is an efficient construction method for grain storage, it requires massive amounts of energy to manufacture. As well, any wet material stored in a steel bin risks rotting, requiring producers to expend more energy to dry the material in-situ. To optimize the producers use, the Granary is assembled from dimensional SPF lumber and Hempcrete. The advantage of the Hempcrete building is the breathability of the container wall which hygrothermally absorbs moisture from any stored material. Instilling new program associations of livestock enclosure and lookout platform offers rural producers a new building typology for vertical integration.

To create a more holistic agricultural building requires the architect-planner-entrepreneur to redevelop the producers process towards sustainability and safety. This allows the Granparent, Parent, and Offspring to experience the Granary together. A spiral staircase replaces bin ladders, livens the Granary wall and initiates a 360° perspective of the rural landscape. At the Granarys coned roof, the lookout platform creates a moment of respite for the rural producer. Material is transferred into and out of the bin using pneumatic conduit, removing the danger presented by grain augers.

Square or Rectangular Bin
 $L \times W \times D = \text{Volume}$

Cylindrical Bin
 $C \times C \times D \times 0.07958 = \text{Volume}$

Hopper Bottom (conical)
 $D \times D \times H \times 0.3145 = \text{Volume}$

Bio-fibre Board laminate creates the structure of the consumer tube. A continuous Hempcrete envelope creates an enclosed processional environment.

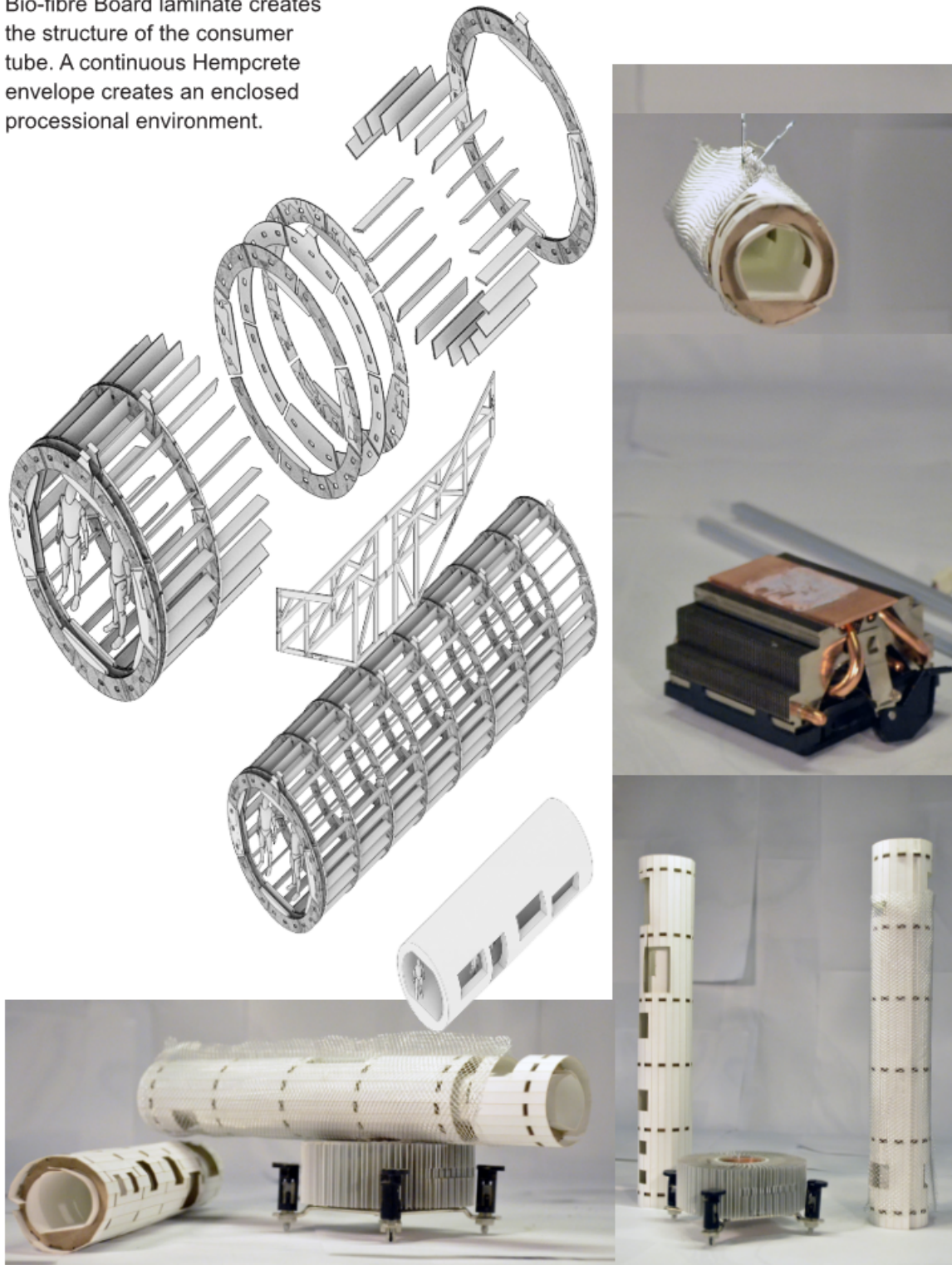

A sealed procession that may intersect any part of the rural process, the Consumer Tube is the rural producers advantage over the corporatized agri-business. Building meaningful relationships between consumers and producers is vital to building resilient rural economies - an experience strengthened through direct mental engagement of the producer.

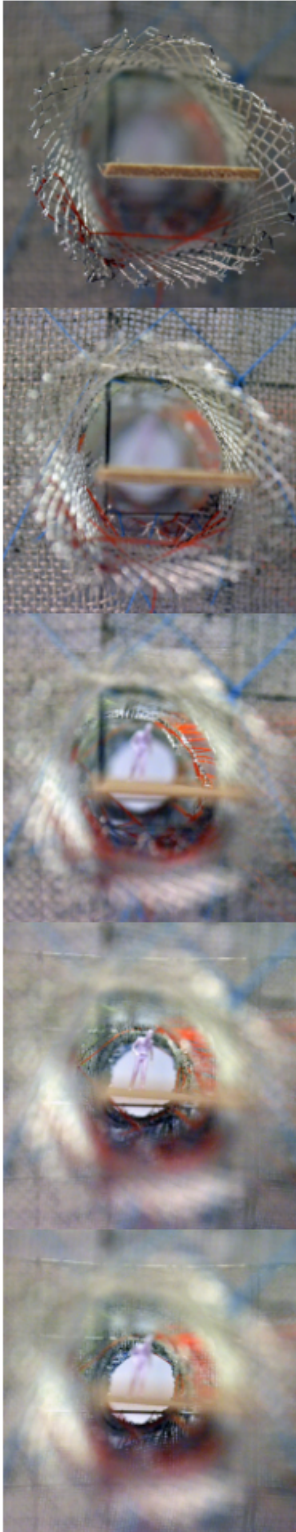

Design_Consumer Tube

As stated before, the urban consumer has lost sight of the rural community, only engaging the rural landscape through the peripheral experience. To create architectural programming that safely moves the consumers procession through the experience of the agricultural process is not a simple task. Especially if the objective of a sustainable community process requires the urban consumer to actively engage and learn the rural lifestyle. Because it is necessary to expose all facets of the producers efforts in order to create a holistic image of the rural landscape, the architect-planner-entrepreneur must consider existing and new typologies for the consumer experience. The Consumer Tube was developed from the concept of the underwater corridors that allow tourists to experience uninhabitable environments. This is to say that the consumer is completely immersed within an ecological habitat without risk of contamination or interference.

The Consumer Tube is constructed from bio-fibre panels to create an interlocking structure that is then suspended from, or rested upon the rural landscape. Structural rings create an interior volume, interspaced with plywood or biofibre panels by 2'-0" increments. The spacers create the support for a continuous Hempcrete envelope and allows for window openings in a 360° perspective. When emplaced, the pneumatic conduit can be attached to the consumer tube, orienting the consumers understanding of the process workflows through the Hempcrete Barn. This leads the Consumer Tube through every aspect of the producers efforts and the manifests the procession of material production into the urban consumer.

Designed to hang from the ceiling of the Barn Module, the Consumer Tube is a versatile learning space that focuses the consumer on the technical and cultural understanding of the local agricultural process. Intended as sensory experience, intertwined with fact, the consumer is isolated from distraction until openings in the Tube wall reveal the relevant landscape, process, and product that confirms the producers lesson.

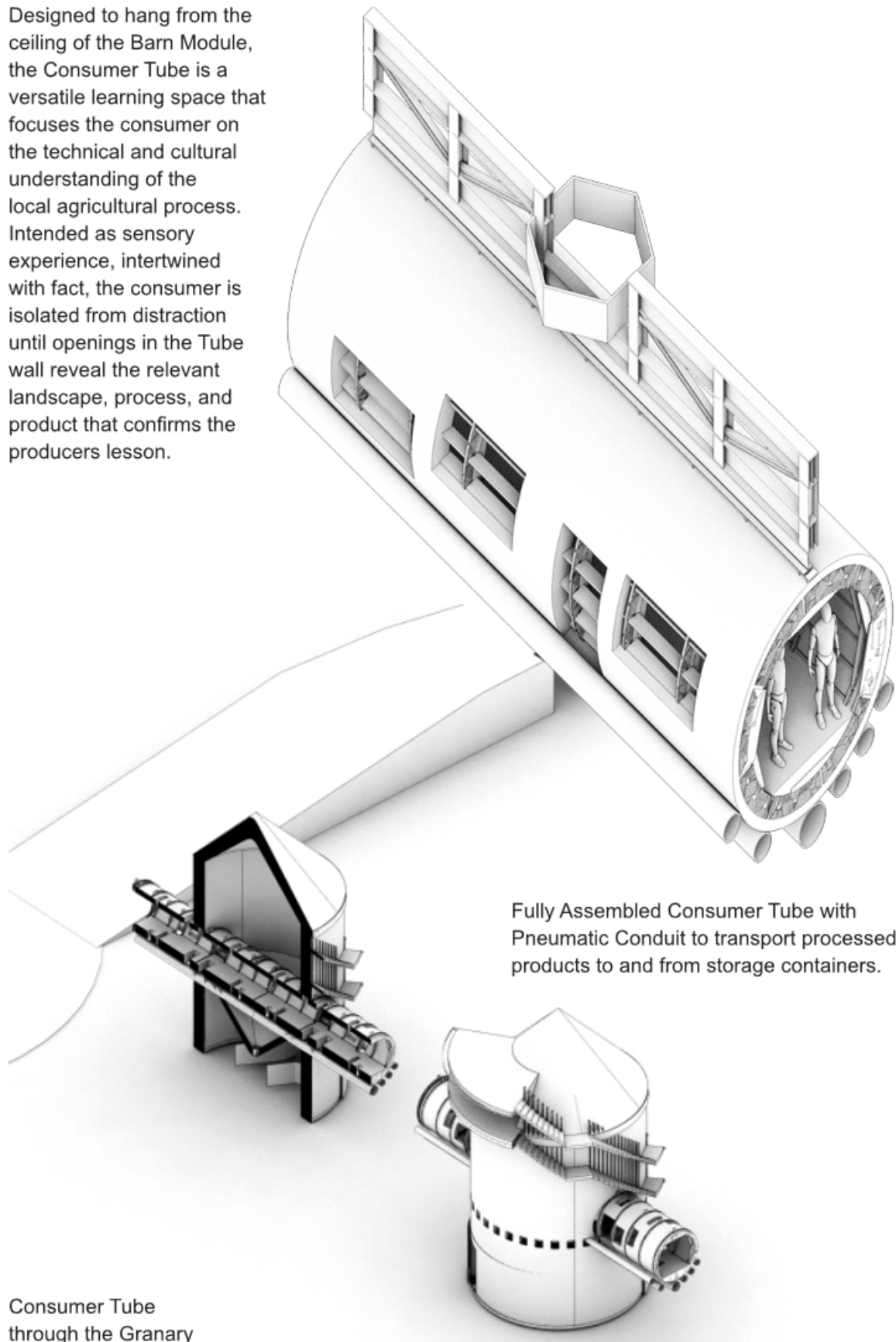

Focusing the consumers experience through a tunnel of Hempcrete is the constant exposure of a sustainable building material that fills the peripheral experience. Openings through the floor, sidewalls, and roof of the Consumer Tube allow for processional route to affix consumer attention to the associative landscape, inputs, and outputs of the agricultural process. Information panels affixed to the walls can expose detailed information and complexity of rural systems without endangering the consumer, or inhibiting the producer. Where possible, the consumer can touch, smell, taste, hear, and feel the agricultural process in motion. Most importantly, the Consumer Tube can be integrated into any agricultural process and allows any consumer to intersect the prairie landscape.

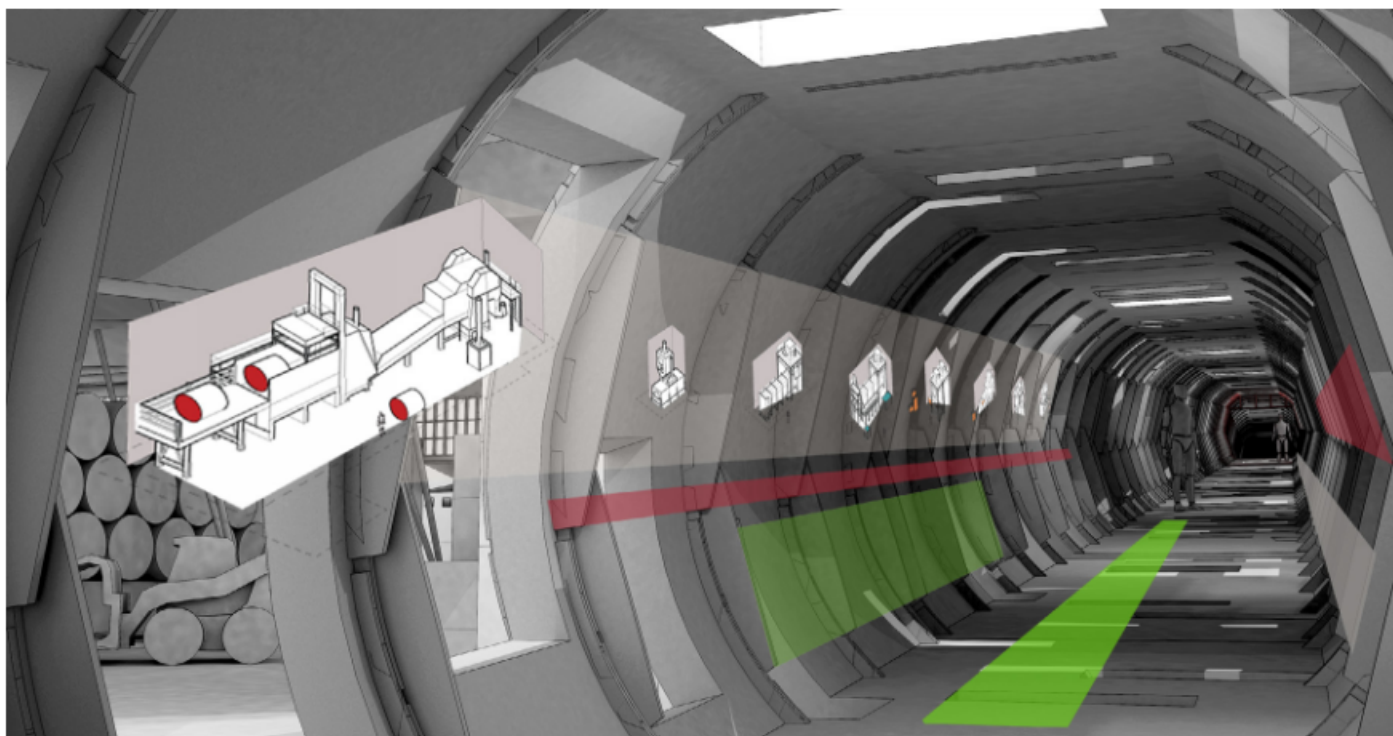

Procession though the Consumer Tube

STAND WITHIN

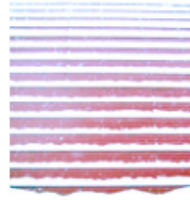

Prefinished Metal Roof

- Prefinished Metal Roof
- 2"x2" Horizontal and Vertical Battens_ maintain 2" airspace
- 1" T&G Wood Fibre Sarking Board
- 2x6 Engineered SPF Wood Frame Truss
- 12" Hempcrete Ceiling Fill, **R25**
- 16" Engineered Open Web Wood Joist @ 24" o.c.
- 2"x2" SPF Wood Noggins
- 3/4" Wood Wool Board

Hempcrete Ceiling Hand Placed

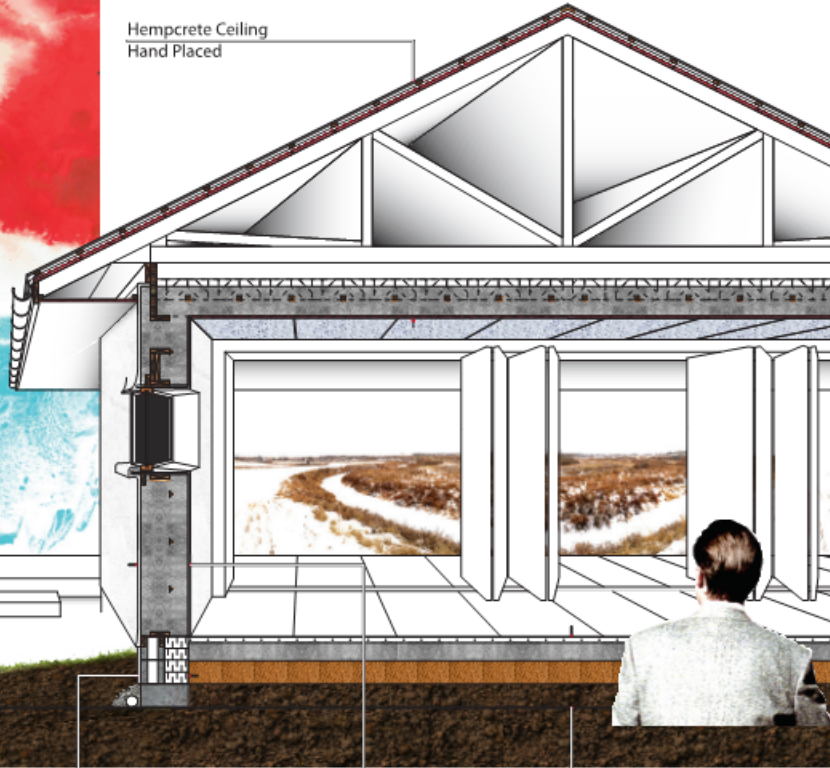

Hempcrete Wall Hand Placed

- 1" min. Lime Cement Exterior Render, Vapour Permeable
- Lime Cement Render Base Coat
- 16" Hempcrete Wall Fill, **R33, .458 MPa**
- 2x6 SPF Wood Framing @ 16" o.c.
- 2"x2" Triangular SPF Wood Noggins
- 1" Lime Cement Interior Render

Foundation Wall

- 1" Cement Parging to ext. face of block wall
- Engineered Concrete Block w/ 8" min. Recycled Glassfoam
- Blocks to inside face of block wall
- 8"x16" Concrete Strip Foundation
- Weeping Tile w/ 6" min. Crushed Gravel Cover

Hempcrete Floor @ Grade Hand Placed

- 3/8" Stone Tile Floor
- 1" Lime Cement Mortar
- 1/2" In-floor Heat Tubing
- 6" Hempcrete Floor Slab, **R14, .836 MPa**
- 8" Coated Expanded Clay Aggregate
- Undisturbed Earth

Wood Wool Board, Vapour Permeable

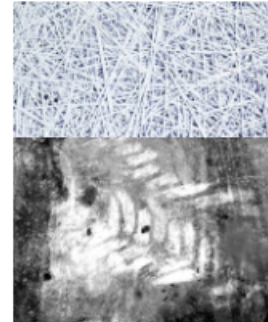

Stone Tile, Vapour Permeable

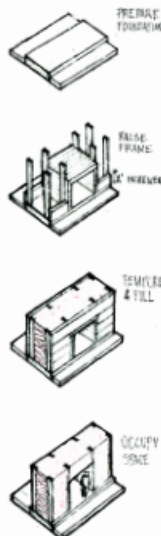

Lime Cement Render, Vapour Permeable

Hempcrete Typology #2_ Cast Wall @ Grade

Section 3: Agro-Architecture

The culmination of the Seed buildings, when interspersed through the rural landscape, directly engages the peripheral experience of the urban consumer - enticing memories and prospect of a sustainable agricultural process. As more individuals begin to recognize that industrial agriculture does not rule the Alberta prairie's, and that generational family farms are the stewards of the rural landscape, then more effort is made on the part of the urban consumer to sustain the economic and environmental systems that support local producers. As Seed buildings spark interest in the rural process, the producer must provide a rural experience to initiate direct relationships with urban consumers. The directive of the architect-planner-entrepreneur is to create venues to demonstrate the producers experience and catalyze the essence of the rural landscape. Because agriculture permeates the basic environmental, social, economic, and cultural traits of our socio-technically oriented culture - crossing the built form scales of residential, commercial, and industrial design - it represents a significant opportunity for sustainable architecture to be exposed for its simplicity.



Hempcrete Exterior Wall - Plaster



Hempcrete Wall - Cast-in-Place

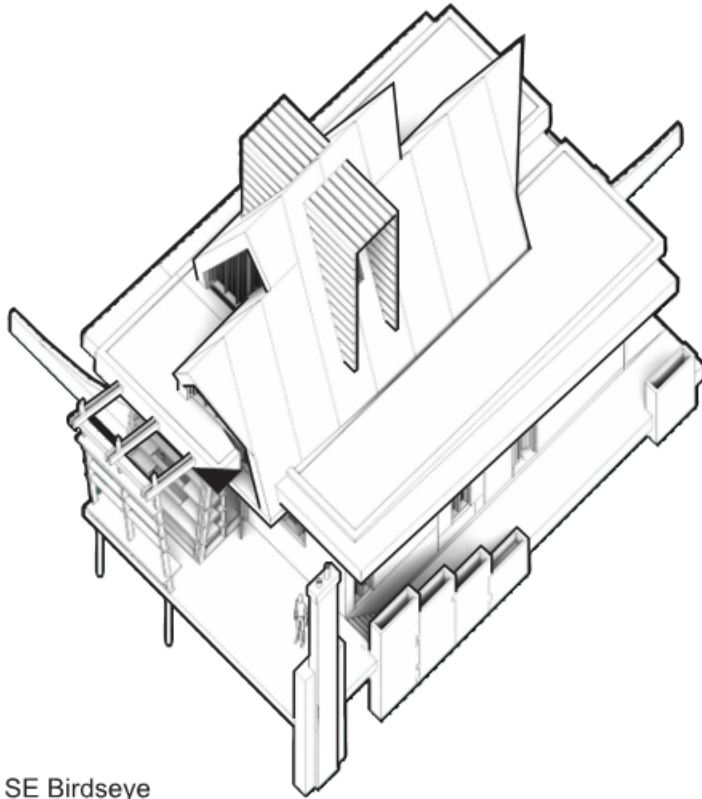

Occupants:	3 - 4
Floor Area:	125 m²
Hempcrete Building Envelope:	225 m³
Estimated Cost of Hempcrete:	\$ 26390

SE Birdseye
Axonometric

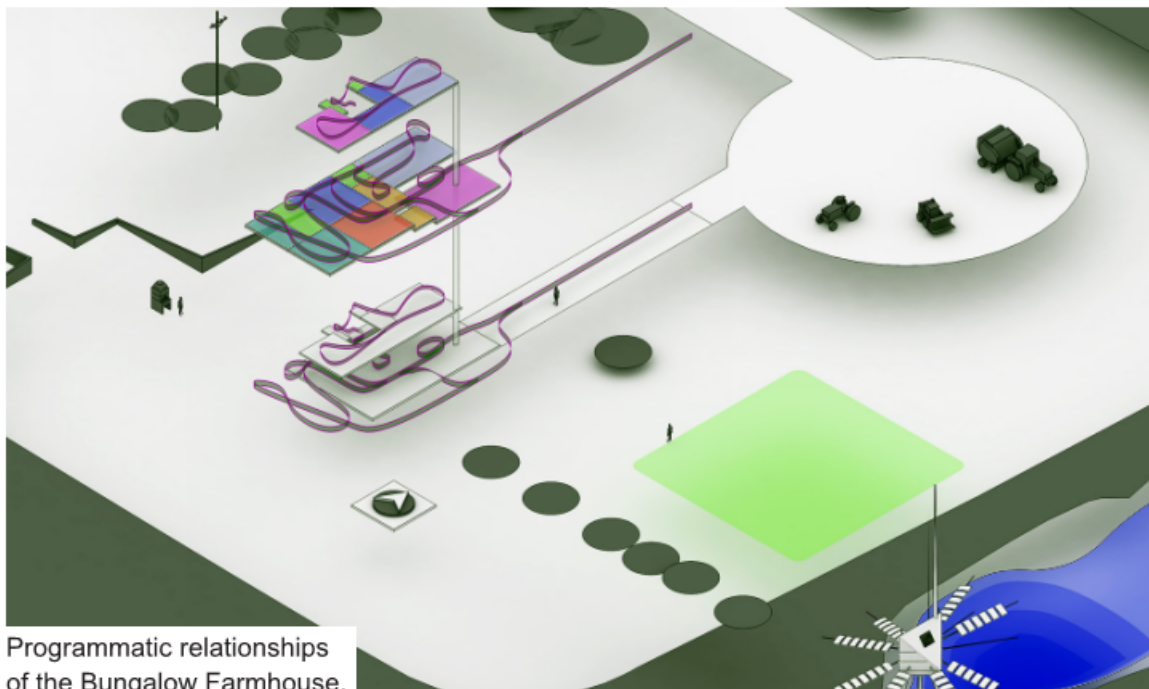

Programmatic relationships
of the Bungalow Farmhouse.

A heated garage, or studio, faces North and the work programming becomes the entrance to the home. Entering onto a sunken porch, procession through the home is oriented to the sun's path and begins in the kitchen/dining room, through the greenhouse/living room, and into the master bedroom. A central bathroom creates a private interior experience for producer rest. An outdoor fireplace creates an exterior room to extend the Live process directly into the rural fabric.

The Bungalow Farmhouse

This residence is intended for the budding rural producer and family. Developed from a 5m x 5m grid, the rooms are configurative, programmed to reflect the rural process. The Bungalow Farmhouse features a 2m x 5m greenhouse at its South face to create interior atmosphere and a living wall for resilient food production. The second storey addition to the stereotypical bungalow is necessary to provide a minimal footprint and economically accommodate a new family. Fashioned after the sod houses of prairie settlers, the steeply pitched roof concentrates heat at the peak of the interior space - heat which is transferred into the continuous Hempcrete envelope via the hygrothermal process.



Garage/ Workshop

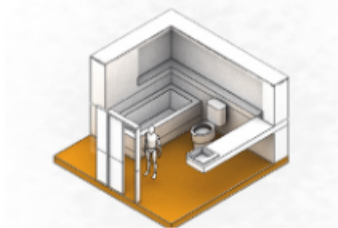

Bath Room

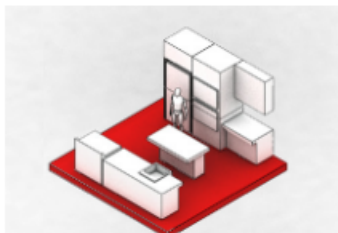

Kitchen

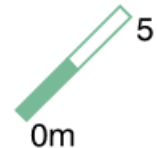
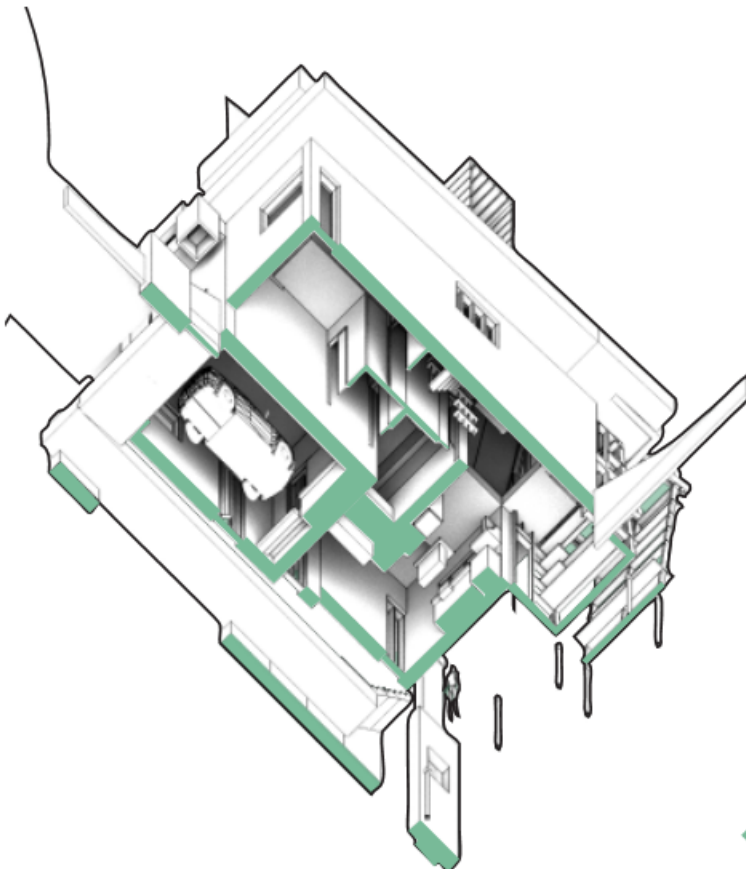

NW Wormseye
Axonometric

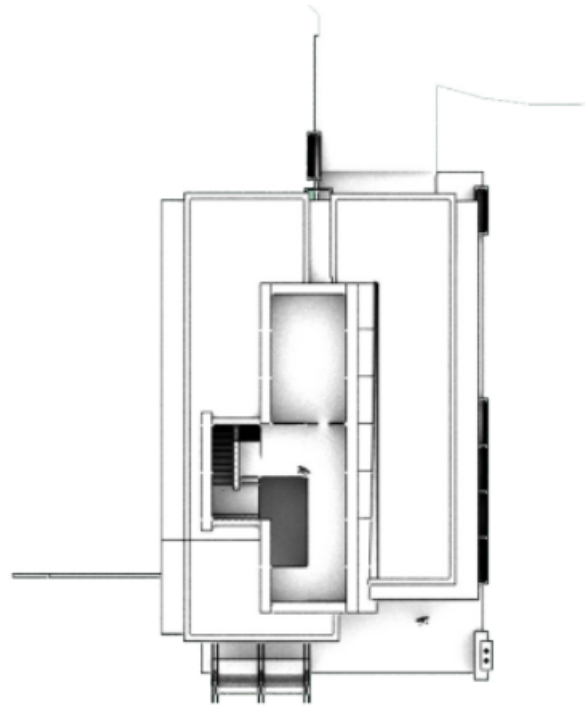
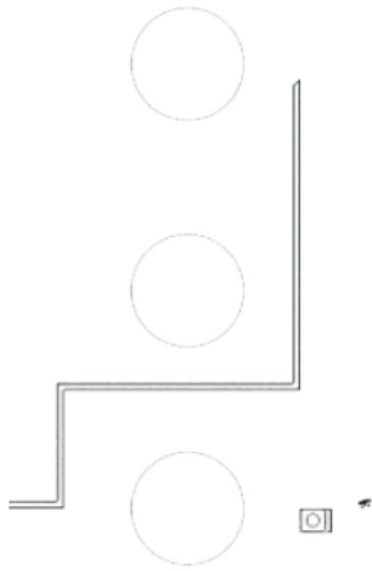

Second Floor Plan

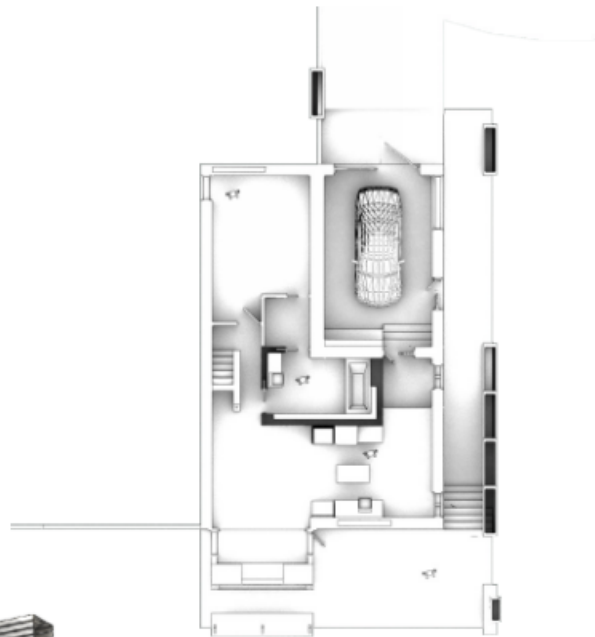
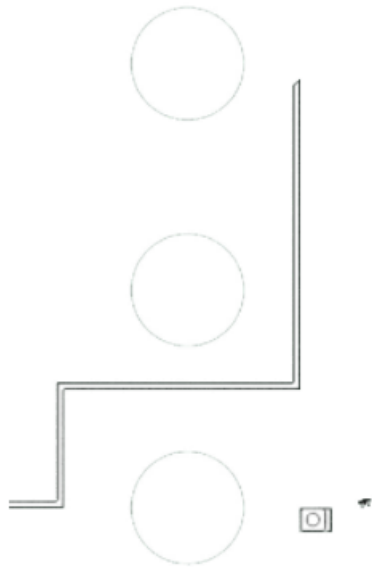
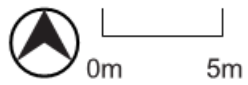

Main Floor Plan

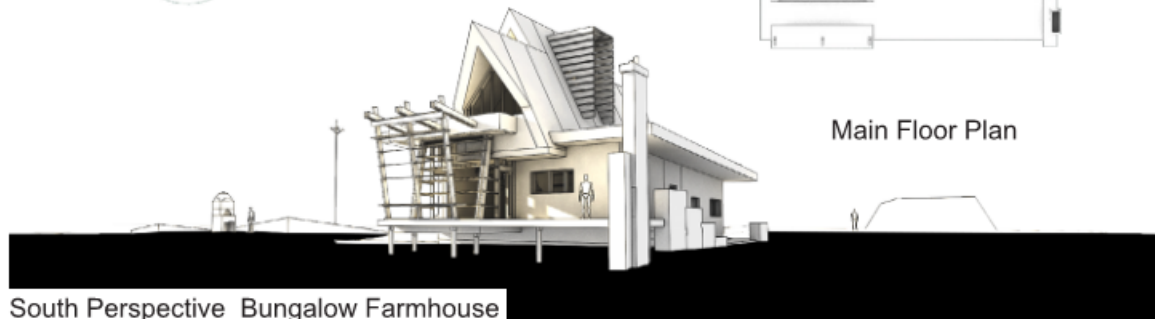

South Perspective_Bungalow Farmhouse

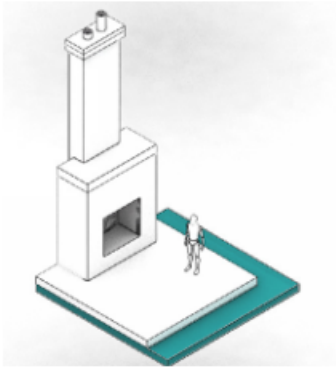

Living Deck

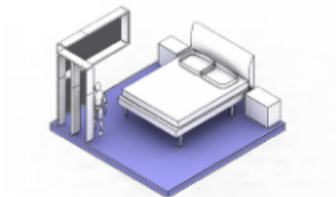

Bed Room

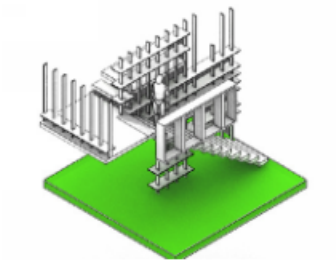

Greenhouse/ Stair



Home Office

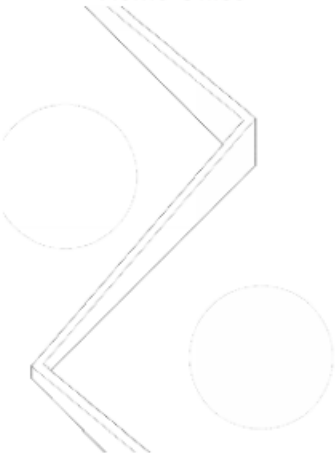

Where possible, internal rooms lend to the food resiliency process by providing living surfaces. These consist of shelving exposed to direct sunlight. Combining productive surfaces with internal circulation provides constant exposure to the agricultural process. Building services are centrally located and consist of a full bath accessed from the stairwell hall, or, through the master bedrooms walk-in-closet. Creating thickened internal walls provides additional heat massing to reduce energy consumption, a mass that can be sculpted into natural forms. Mechanical services are hidden under the living space in a plenum floor, which actively distributes warm air to interior rooms. Greywater storage tanks placed in the plenum floor collect runoff from the greenroof to be re-used for domestic chores and an interior garden.

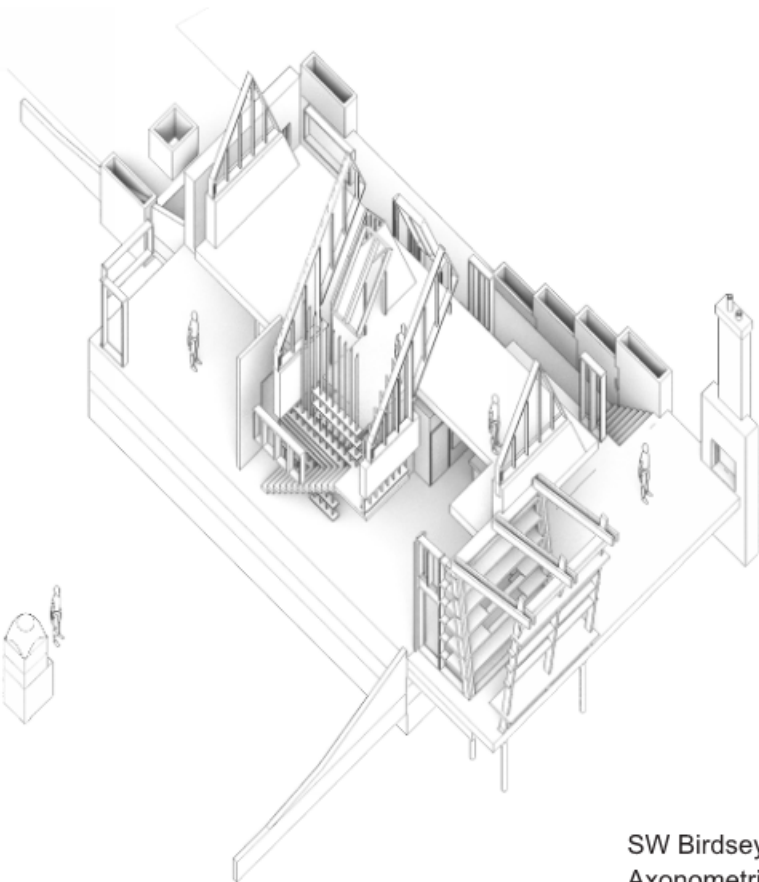

SW Birdseye
Axonometric

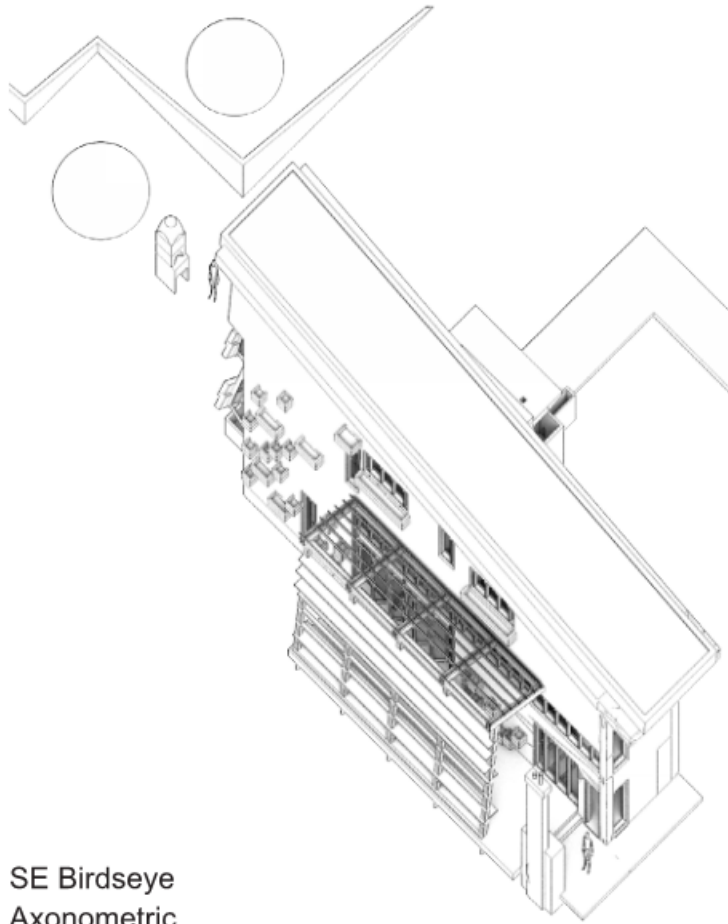

Occupants: 3 - 4

Floor Area: 150 m²

Hempcrete
Building Envelope: 315 m³

Estimated Cost of
Hempcrete: \$ 36950

Saltbox Homecoming.
With no attached garage, the Saltbox is focused on living in the rural landscape for the appreciation of its natural beauty. Bedrooms are lifted to the second storey to provide scenic panoramas to the occupants, create a heat stack for energy conservation.

SE Birdseye
Axonometric

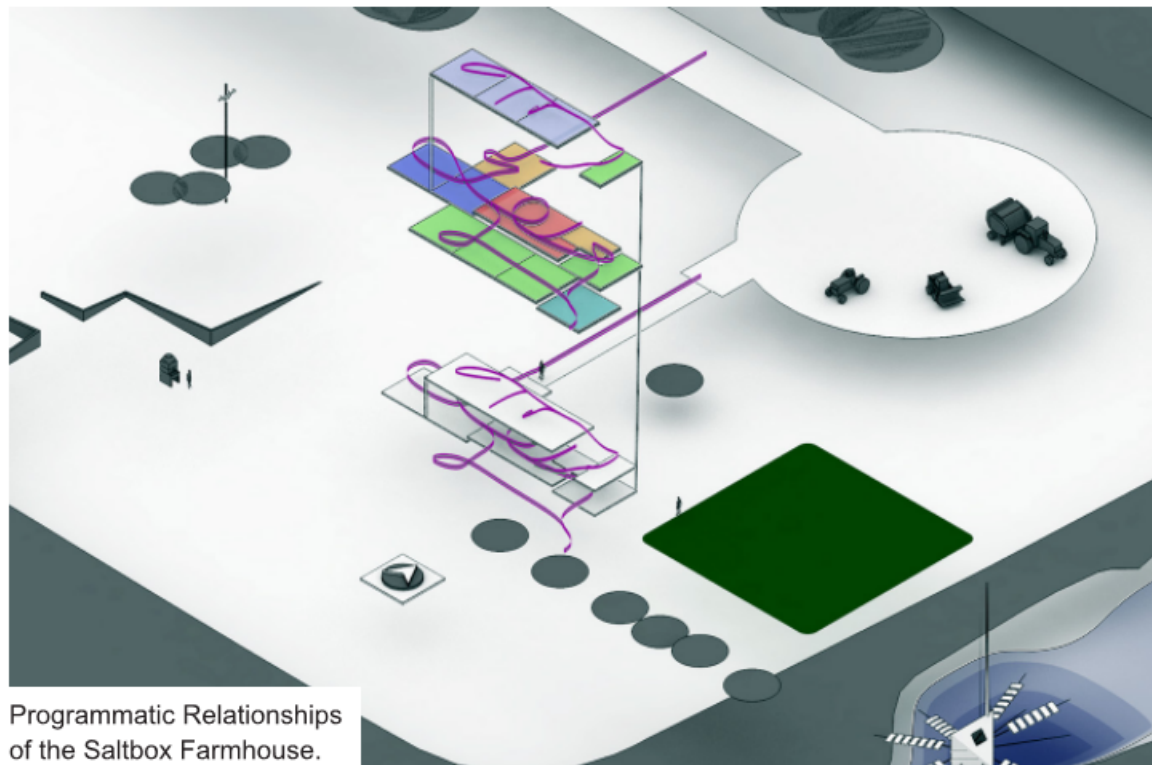

Programmatic Relationships
of the Saltbox Farmhouse.

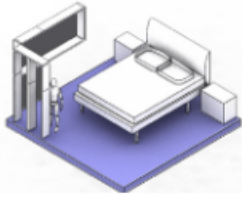

Bed Room

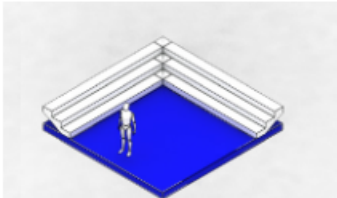

Living Room



Bannock Oven

The Saltbox Farmhouse

The Saltbox is designed for established producers that seek a more spatially accommodating farmhouse. A rectangular volume oriented West by East allows for thermal heat massing, capturing natural sunlight throughout the day. An exterior deck extends the Live/Work/Play area into the prairie landscape, capped by an exterior fireplace that looks onto a grain field vista. Visitors approach the Saltbox from the North and are greeted by a single storey porch, as the two storey house rises behind. The porch is essential to the interface between a formal interior and rugged exterior. At its West end, the peak volume denotes the living room and interior greenhouse wall/bookshelf. Moving East from the living room, the kitchen and bathroom are aligned to the

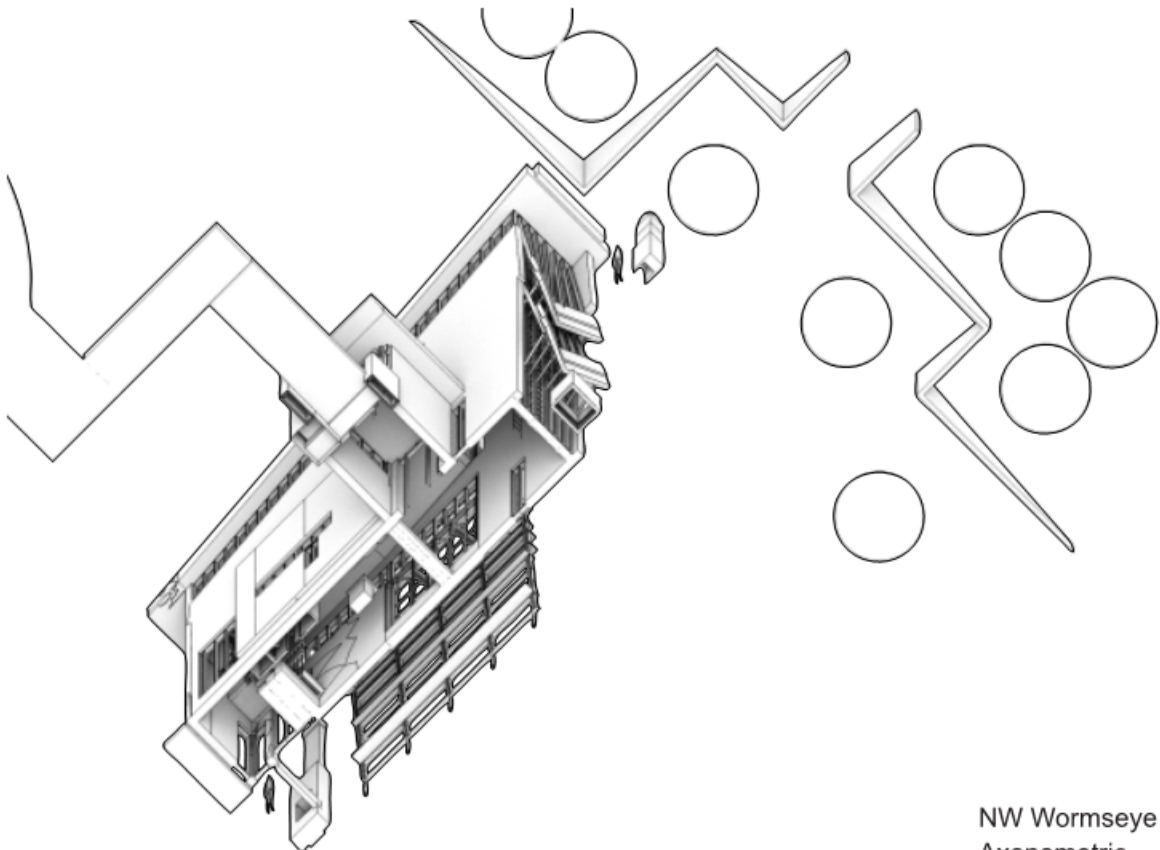

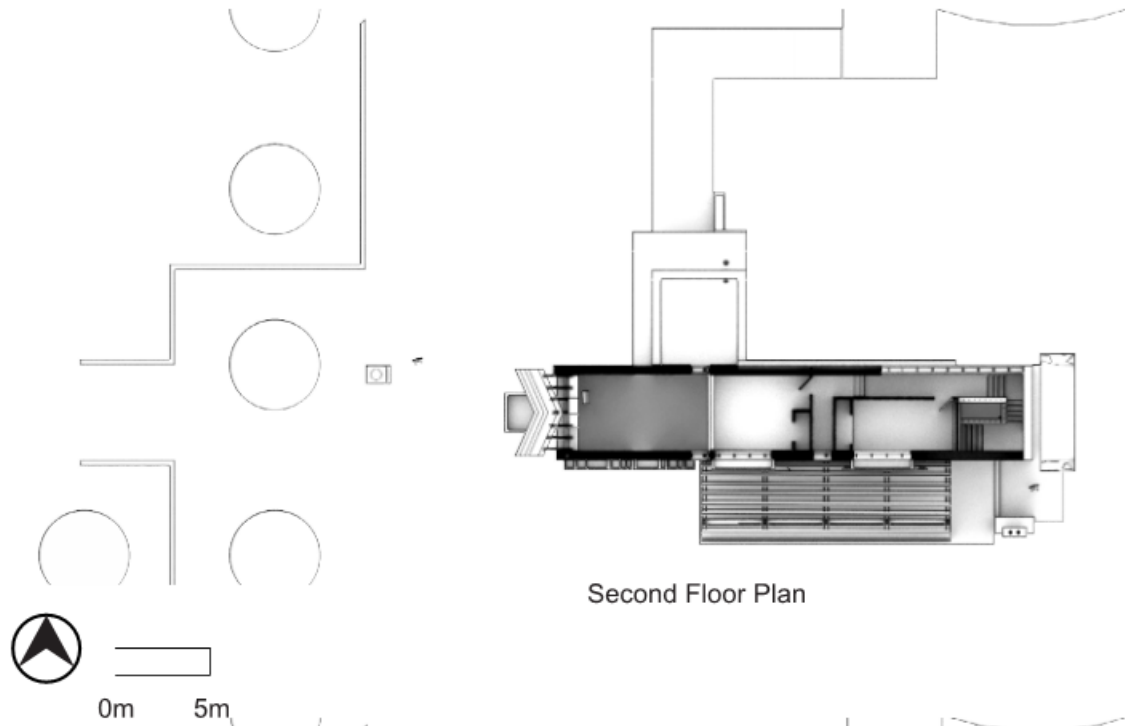

Second Floor Plan

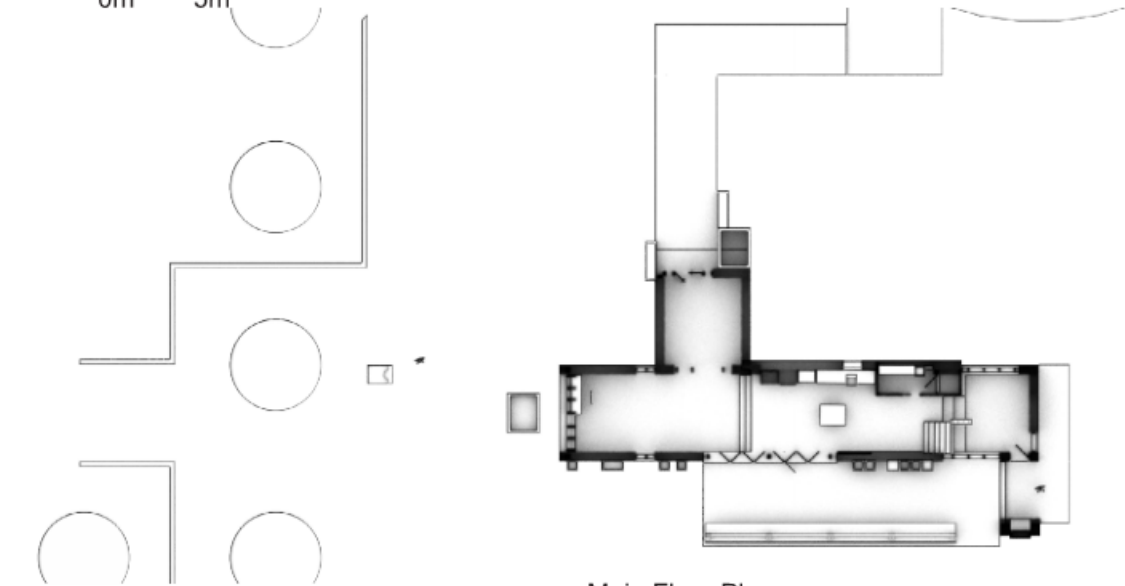

Main Floor Plan

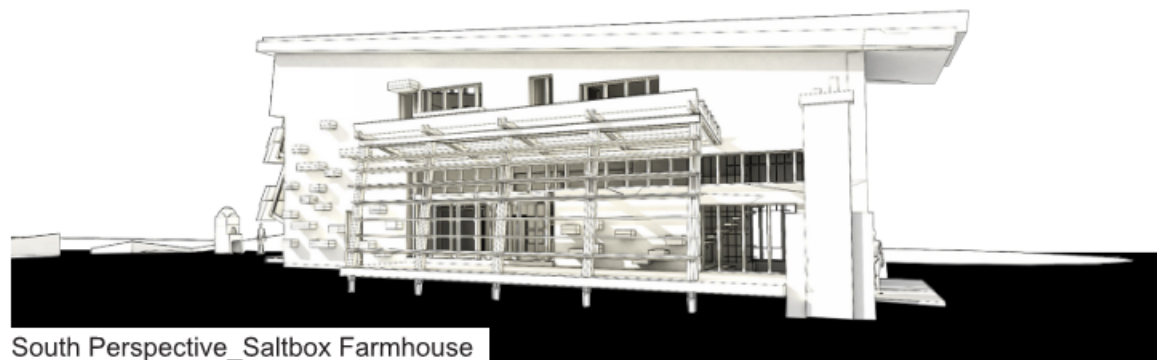

South Perspective_Saltbox Farmhouse



Kitchen/ Greenhouse

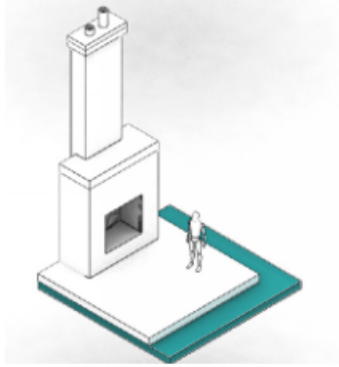

Living Deck



Landscape Features

North wall to allow for a continuous interior volume, opening the South Wall to the productive landscape and passive solar heating. An exterior deck is accessed through a folding wall of glass doors, shaded by an open greenhouse frame and finished by an exterior fireplace, extending the interior living room.

The intention of the Saltbox house is to express the living room as the internal social center of the farmhouse, and requires the manipulation of mass and space to connect the entire dwelling. A three storey living wall caps the West end of the Saltbox, accessed by a floor to ceiling ladder, providing shelf space for family memorabilia or potted plants. A full height glazing wall, shielded by floating Hempcrete panels, captures the warming light of a setting prairie sun.

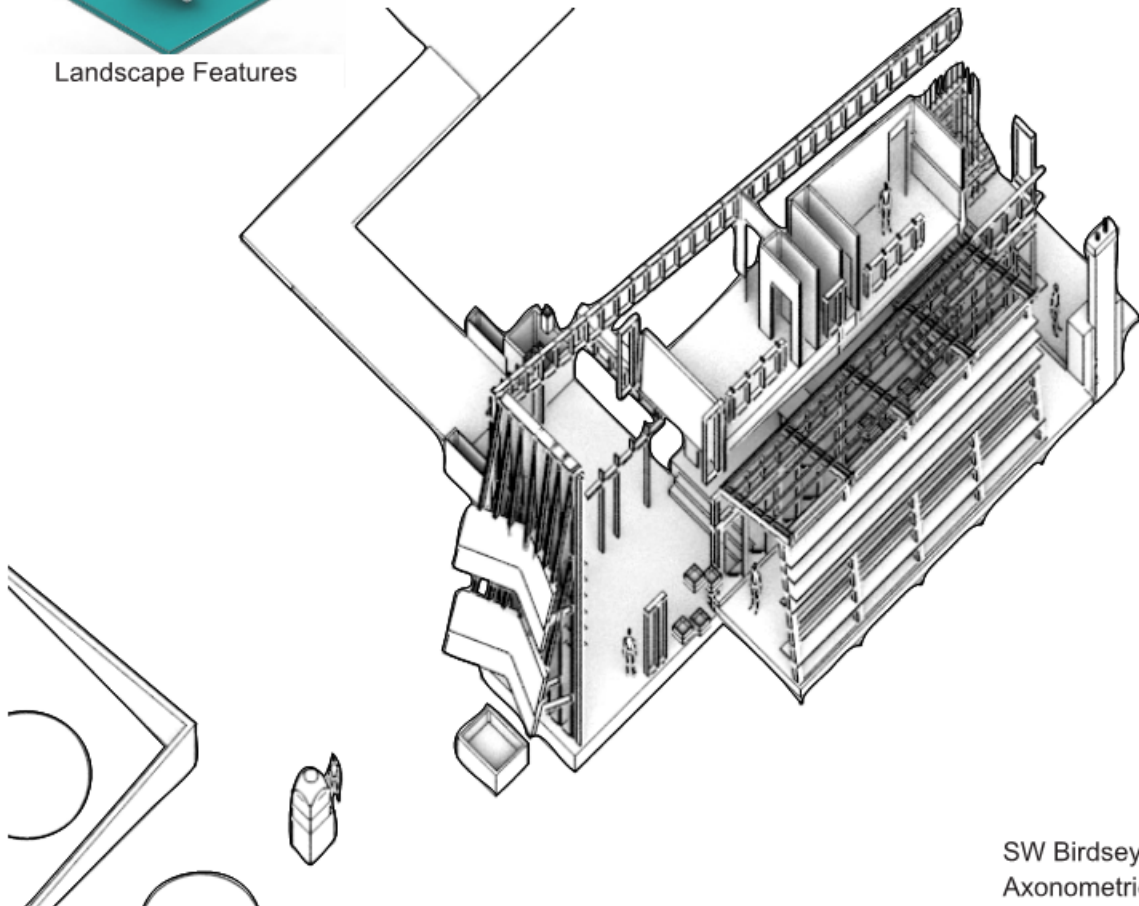

SW Birdseye
Axonometric

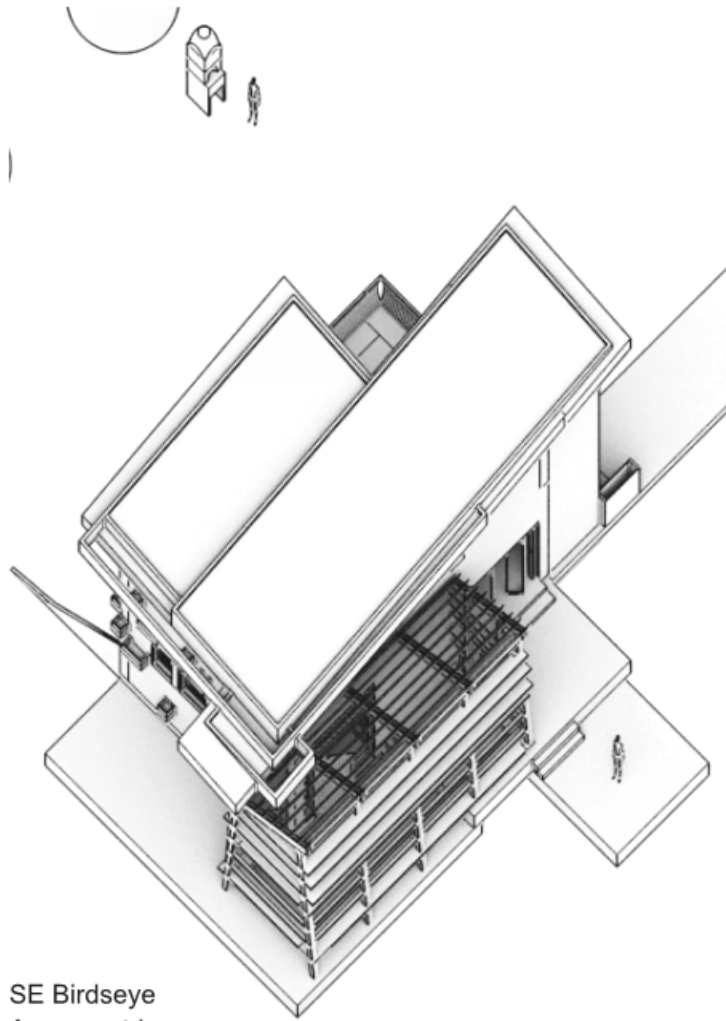

SE Birdseye
Axonometric

Occupants: **6-8**

Floor Area: **150 m²**

Hempcrete
Building Envelope: **360 m³**

Estimated Cost of
Hempcrete: **\$ 42230**

Stacked Homecoming.

The entrance hall of this residence speaks to the act of arrival on the generational farmstead. Beyond all social and cultural boundaries, the farmhouse must present a welcome homecoming.

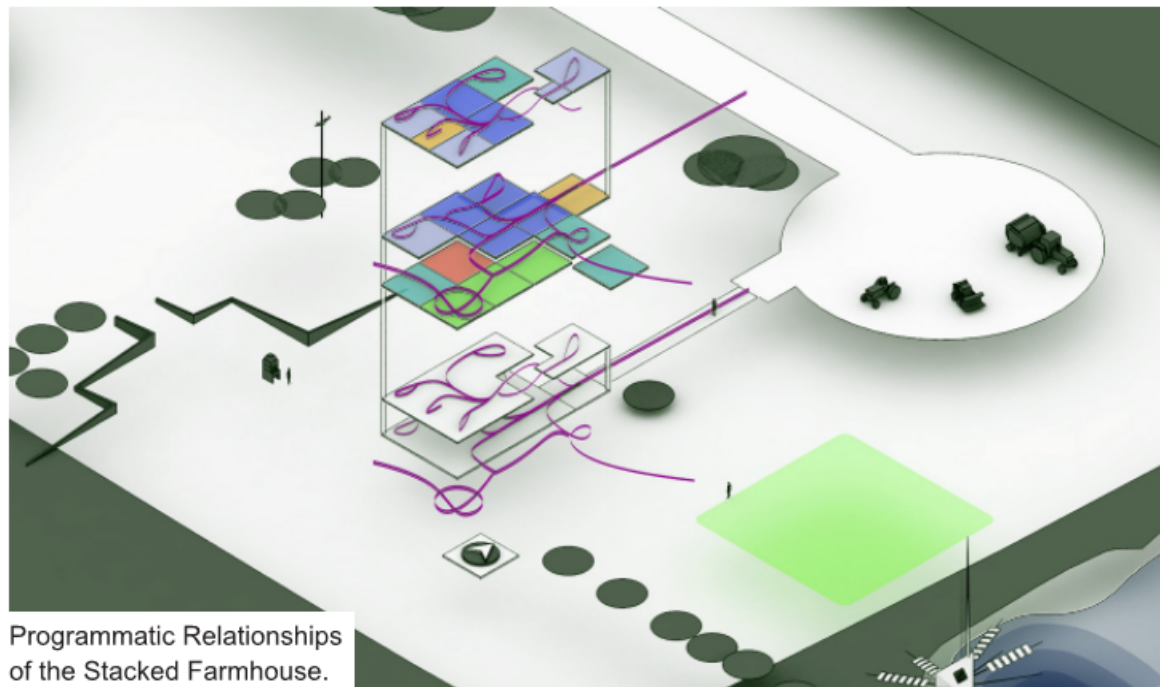

Programmatic Relationships
of the Stacked Farmhouse.

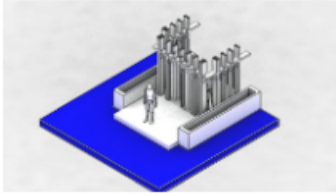

Entrance

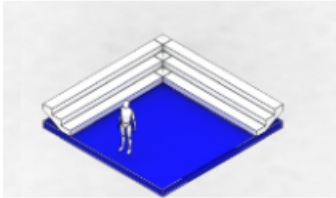

Living Room



Bunkhouse

The Stacked Farmhouse

Stacked Farmhouse was designed to accommodate an expanding family household with an established agricultural process. Designed to be heated using passive solar, the house also features a large greenroof for greywater collection. A stacked program massing reduces the footprint and orients procession of occupants to view the productive landscape. Large openings are placed in the East wall to brighten the producers morning routine, providing ambient light to an internal hall and sunken living room. A unique feature of the Stacked farmhouse is a large double door that opens the kitchen directly into the greenhouse, extending living space to the exterior.

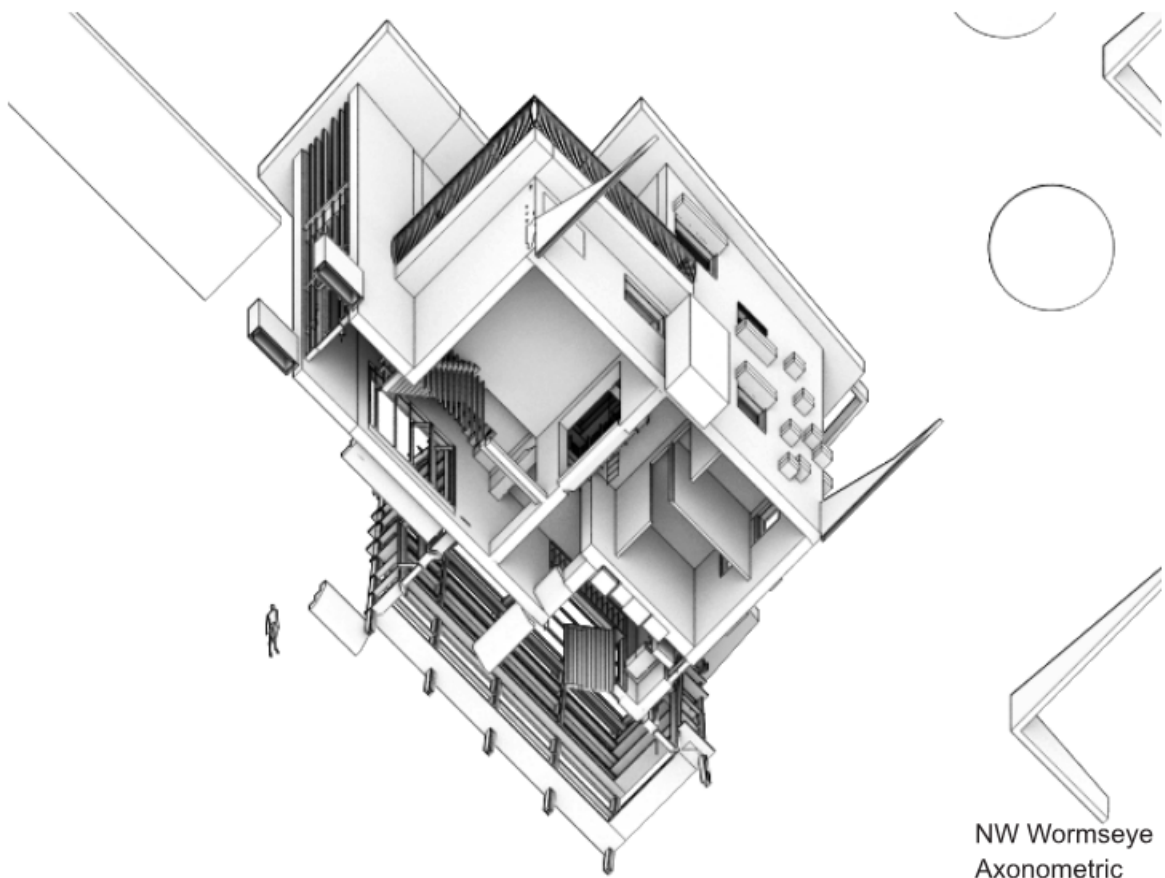

NW Wormseye
Axonometric

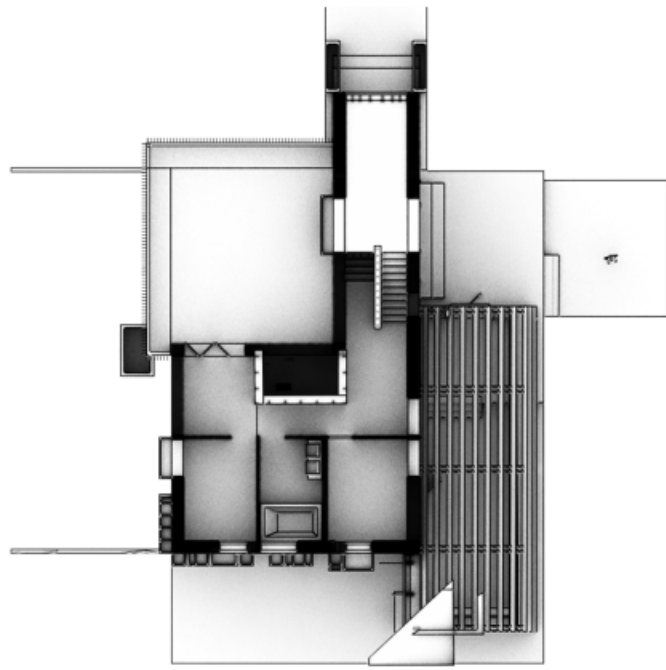
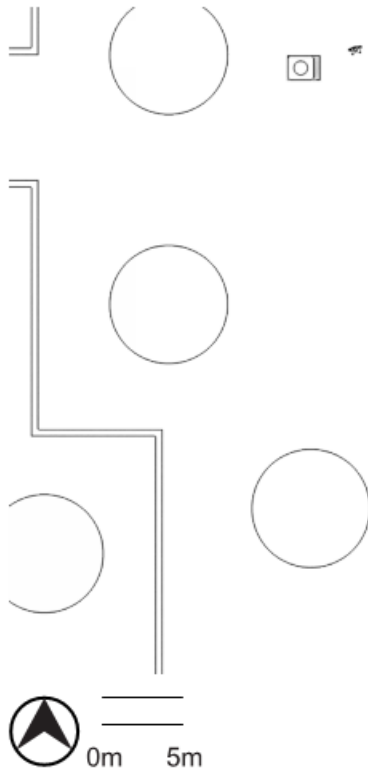

Second Floor Plan

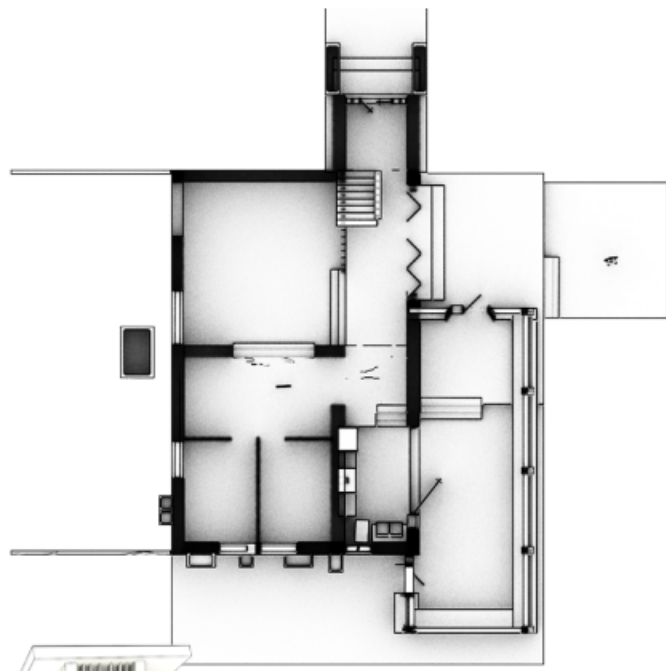
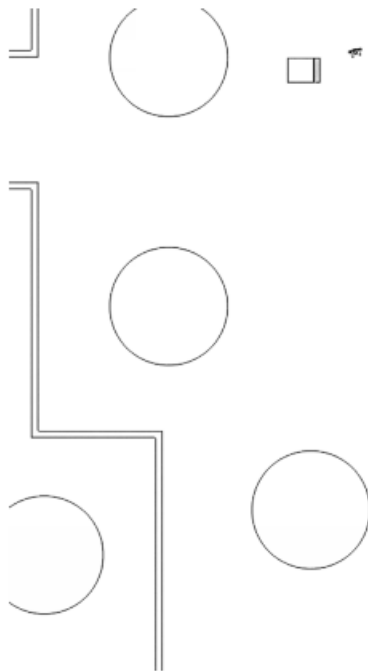

Main Floor Plan

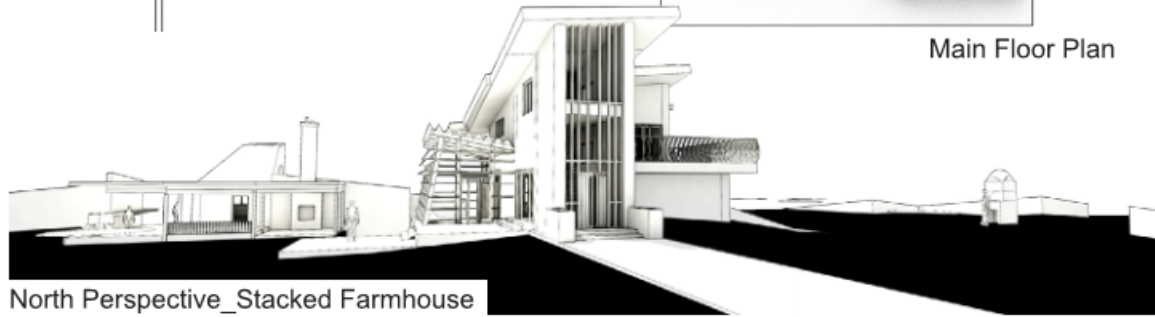

North Perspective_Stacked Farmhouse



Kitchen/ Greenhouse

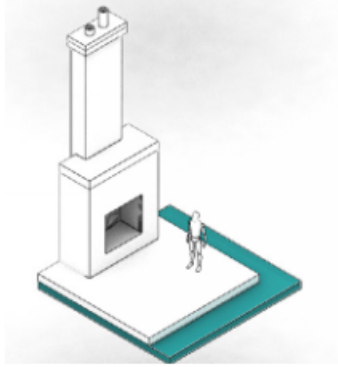

Living Deck

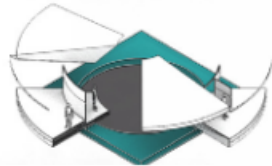

Lookout

Building form expresses the 5m x 5m programming, lifting occupants to the second storey patio facing Northwest to view the sunset and northern lights. A studio/office sits above the porch entrance facing North and expressing a high ceiling point for pooling rising heat dissipated through the Hempcrete envelope. At its heart, the Stacked farmhouse features a dining room which connects to the second storey via an atrium, enclosed by a living wall that hosts plant life. This iteration of the rural residence affords the rural producer a more luxurious experience of the rural landscape, and is supplemented with Seed Buildings like the RE-Tower and the Smokehouse to complete a holistic Live/Work/Play lifestyle.

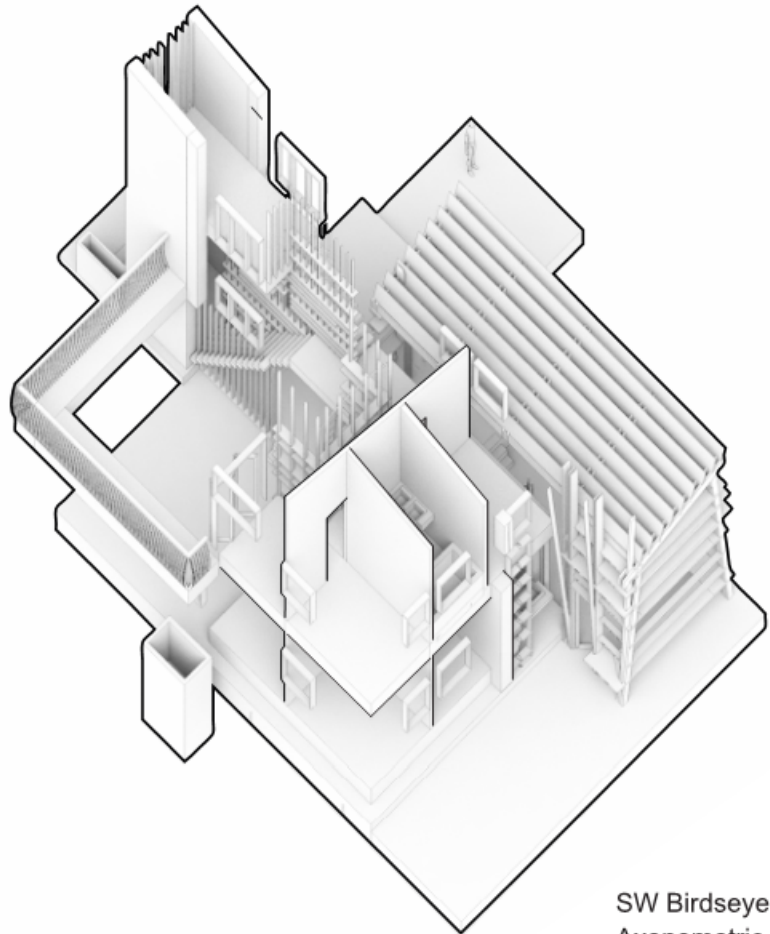
SW Birdseye
Axonometric

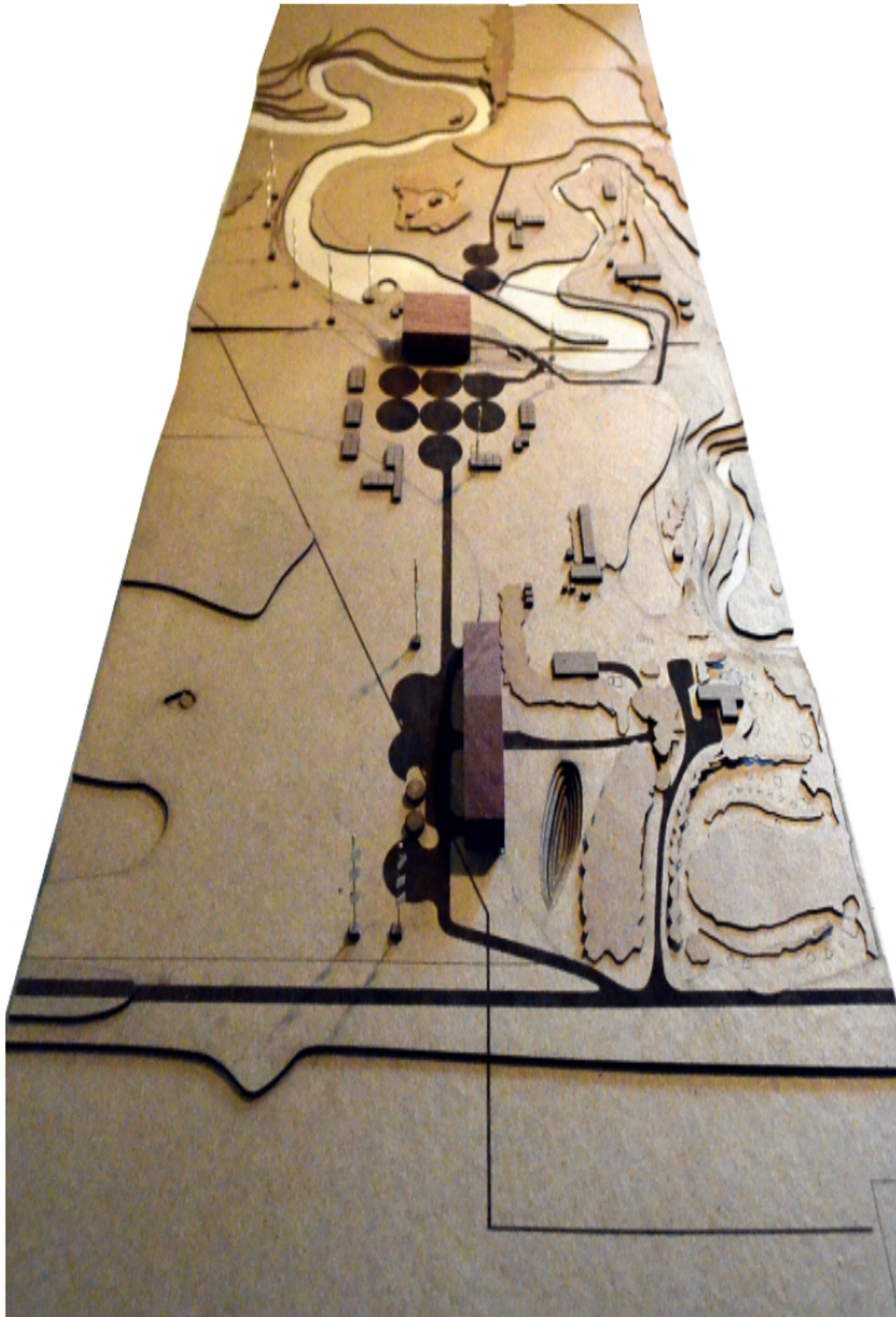

West Perspective of Study Site 2_The Community Hall and the Offspring Farm Realized

Section 4: The Harvest

In treating the rural landscape as a complex iteration of our socio-technical culture has revealed not one architectural response but many. Despite vernacular typologies of the agricultural process, producers are individuals with unique conceptions of the agricultural process and the rural lifestyle. Therefore, the architect-planner-entrepreneur must not denounce complexity, but develop multiple responses to simplify the elements of a design language. Having developed a collection of agricultural buildings that respond to the producers process, surmised through the Seed buildings and generational farmhouses, design can focus on the elements that are still missing from the resilient rural community - the decortication facility and the community hall. Each presents a challenge to the existing models of rural community that rural producers and urban consumers must engage to ensure sustainability.

This section represents the culmination of this thesis design work, demonstrating how buildings are not static, but intricate system proponents that help regulate agricultural inputs and outputs. Within the realm of agriculture, the generational rural producer is the most effective system regulator when entrenched with community oriented values for stewardship. Most importantly, urban consumers must learn that generational family farmers work harder, longer, and through more hell than any other occupation - assuming all inherent risk and opportunity as a personal affront to their ability to provide for their family and their community. Above all else, the rural producer must be characterized as heroes of human endeavour in technologically advanced world.

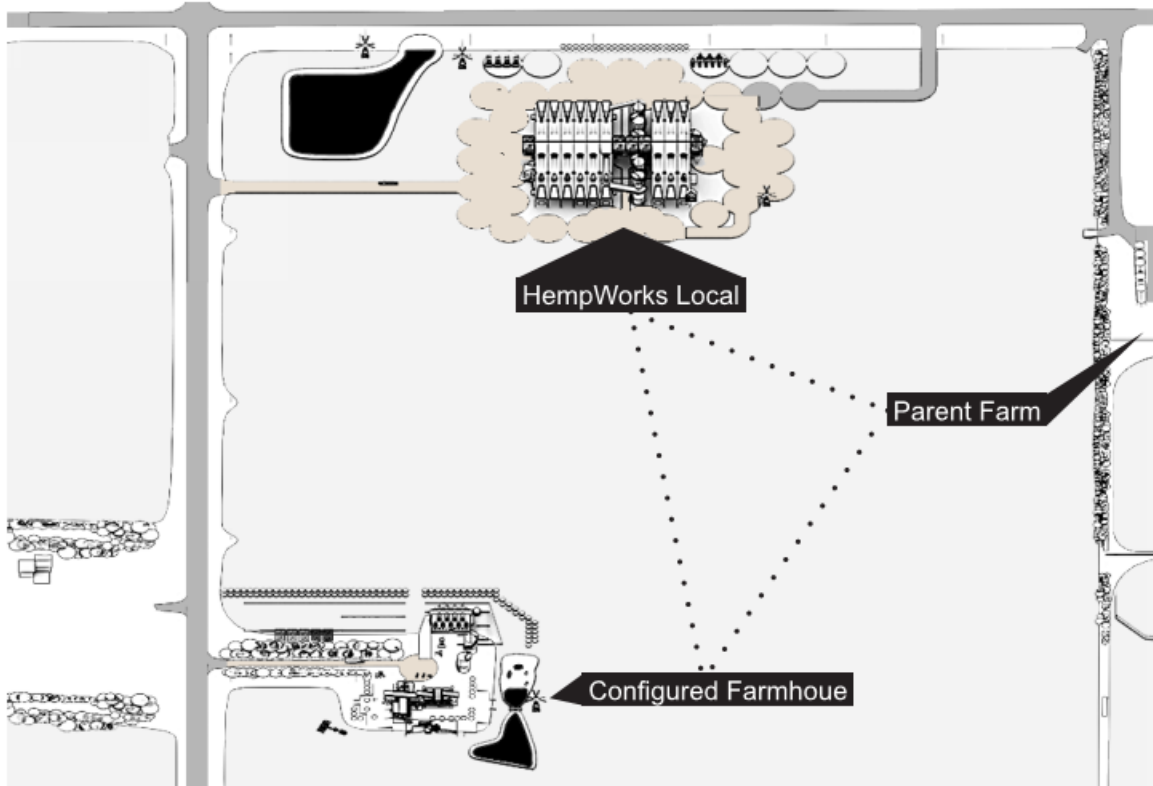

South East Isometric of Study Site 1 showing the relationship of the Generational Farmyard to the Decortication Facility and the Parent Farm.

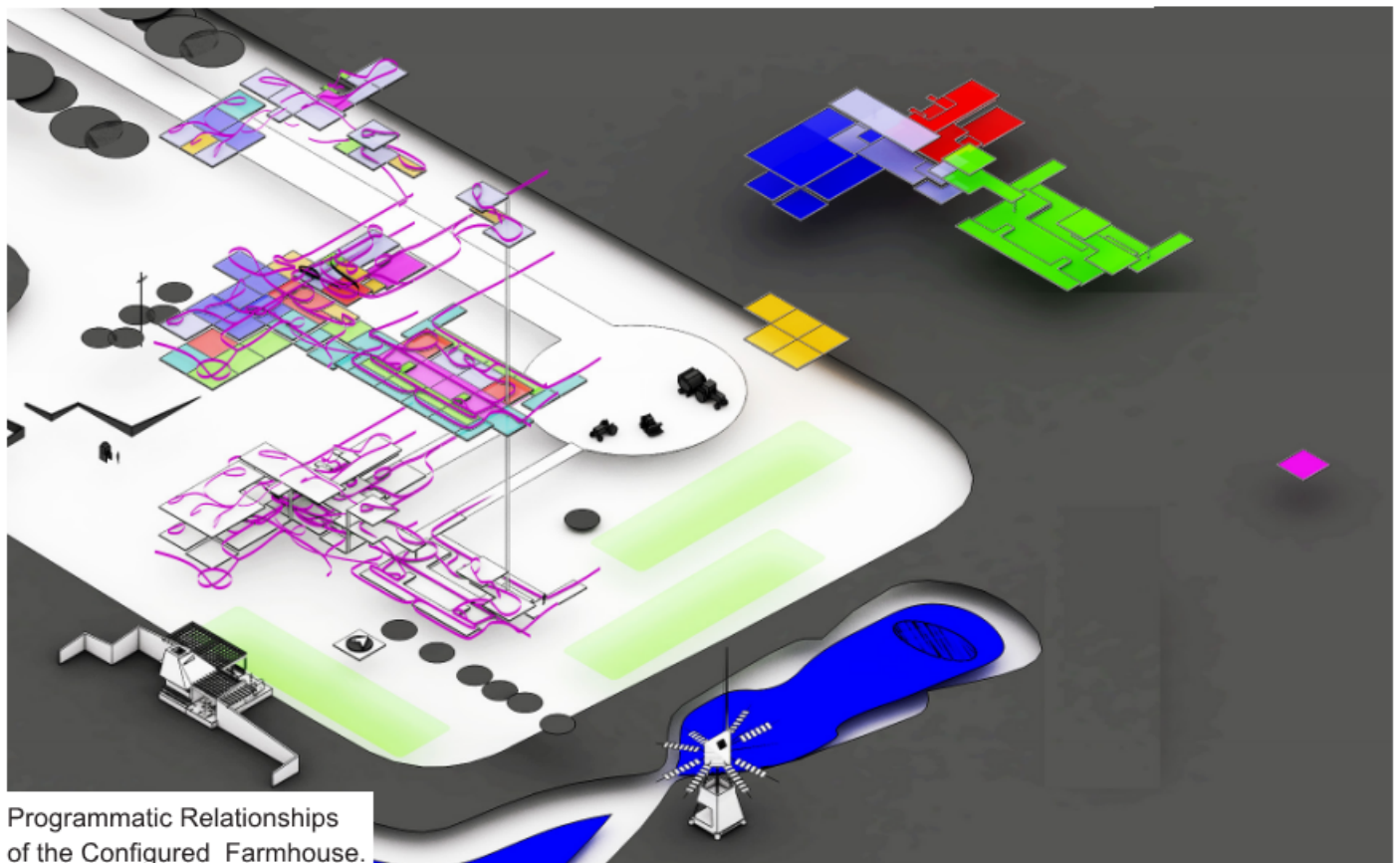

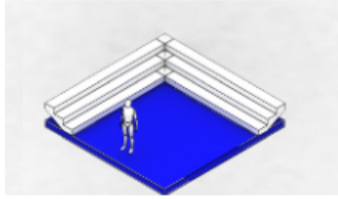

Living Room



Bunkhouse

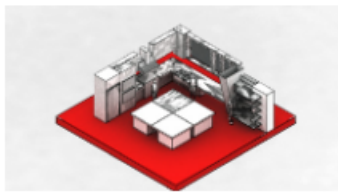

Commercial Kitchen

Live_The Configured Farmhouse

The Configured Farmhouse is the realization that family farms do grow, and over time, the farmhouse must grow with it. Over time, the farmyard is developed to establish the rural producers resilient process, focusing on self-sufficient food and energy production that grows in response to environment. The fully developed farmhouse can accommodate multiple families and employees that each assist in the operation of a generational family farm. As such, this farmhouse is the assemblage of the Greenhouse, Bungalow, Saltbox, and Stacked farmhouses - homes within homes. It should be made clear, that the Configured farmhouse represents a 100-year development of a generational farming process, initiated by the establishment of an RE-tower and one iteration of farmhouse that responds to the producers need for a rural lifestyle.

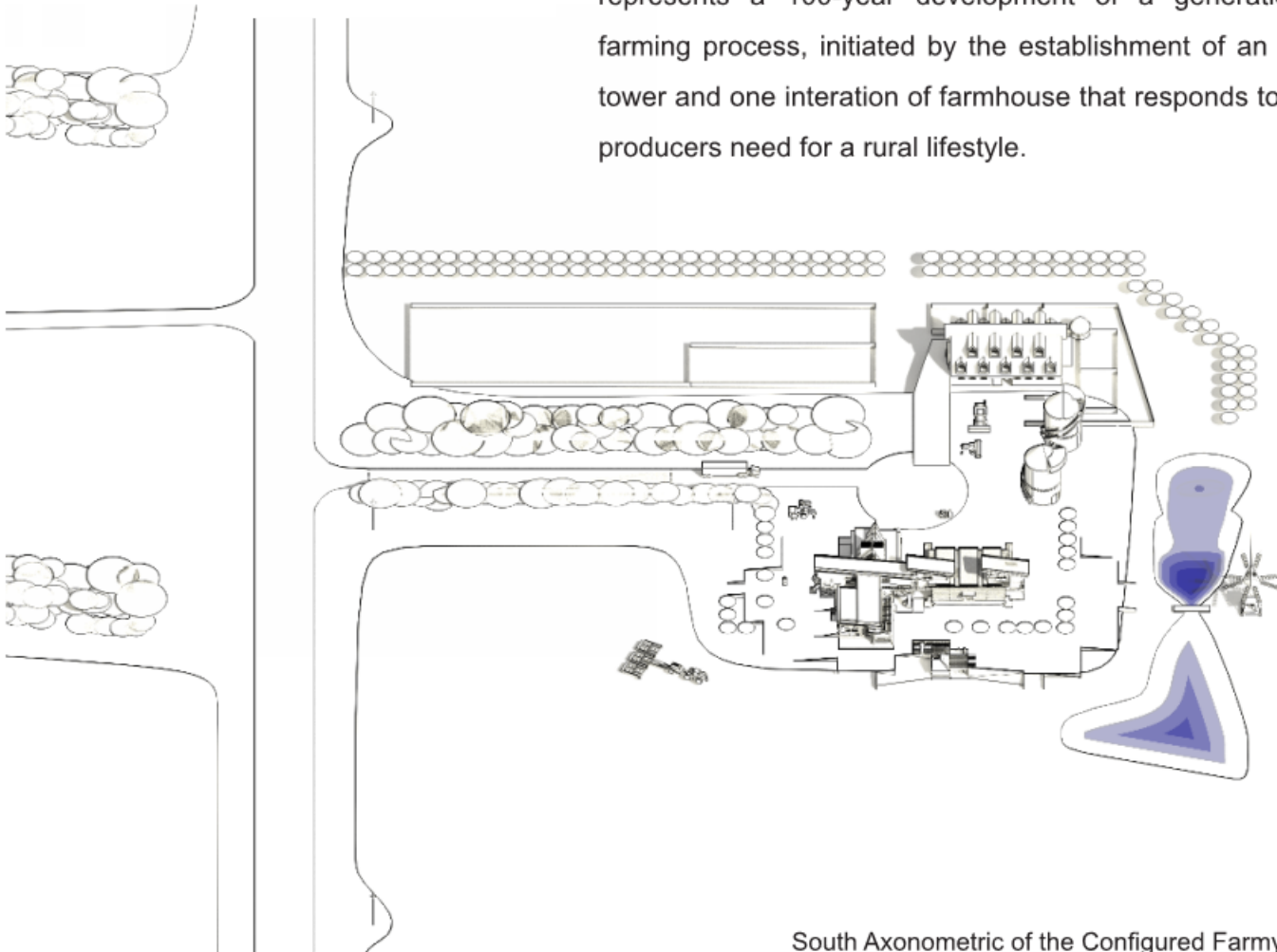

South Axonometric of the Configured Farmyard.

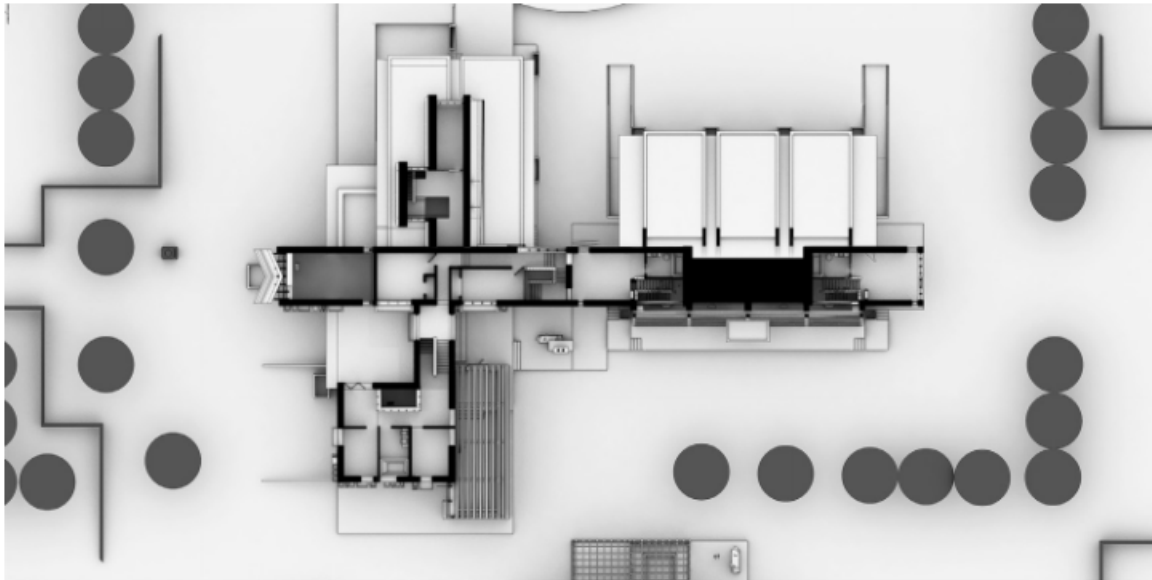

Second Floor Plan

Occupants: **10 - 18**



Main Floor Plan

Floor Area: **650 m²**



East by West Building Section



Garage/ Workshop

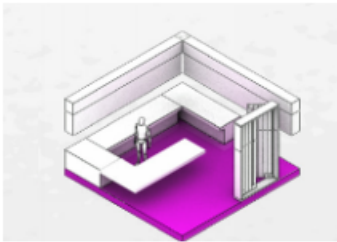

Home Office

As each generation of the family farm creates more family members, each with unique Live/Work/Play lifestyle requirements, the generational farmhouse is a conglomeration of architectural responses that meets those needs. Specifically, the Configured farmhouse allows rural producers to establish a process that allows additional generations to proliferate and refine the families agricultural process. Given the plasticity of the Hempcrete wall, additions and subtractions of architectural programming are easily made by the producer and growing family. Through the process of petrification, the Hempcrete wall attains permanence yet is fully recyclable.

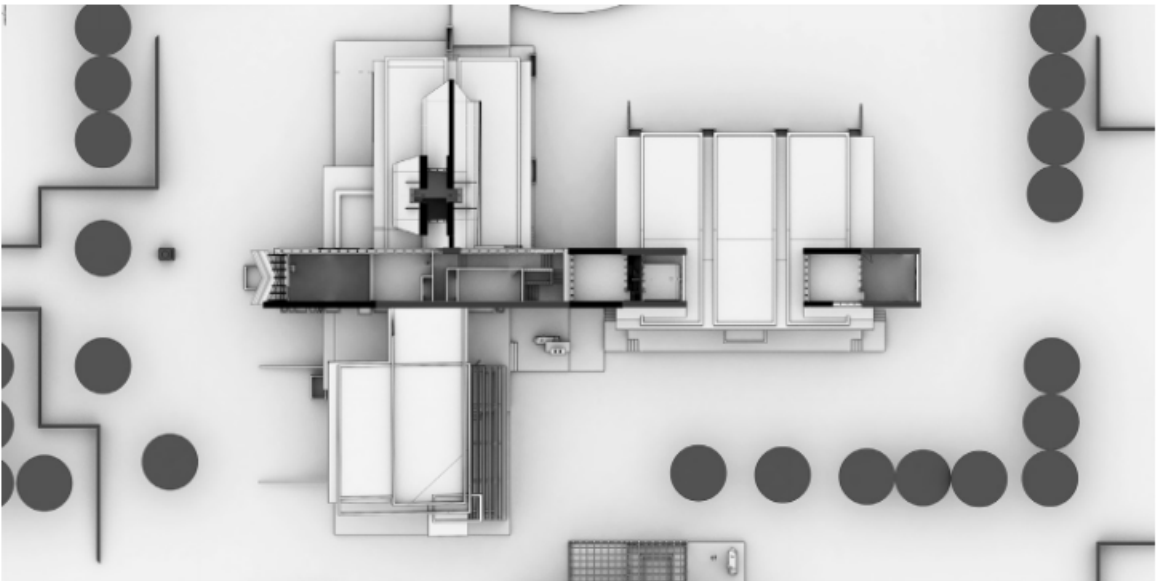

Third Floor Plan



South by North Building Section

Individual



Producer/ Consumer

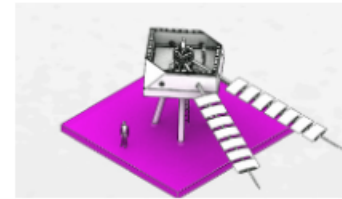

Renewable Energy



Hot Tub

Community



Bannock Oven

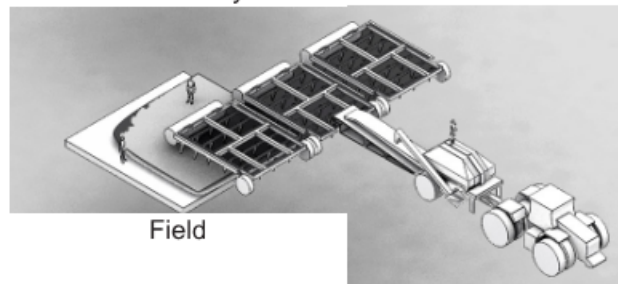

Field



SouthWest Perspective_Configured Farmhouse

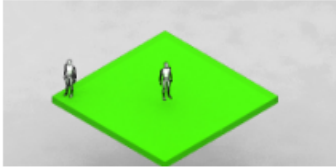

Natural Landscape

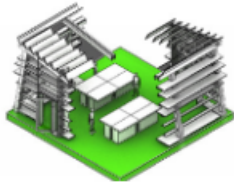

Commercial Greenhouse

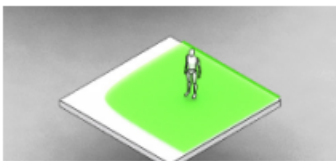

Farmstead Garden

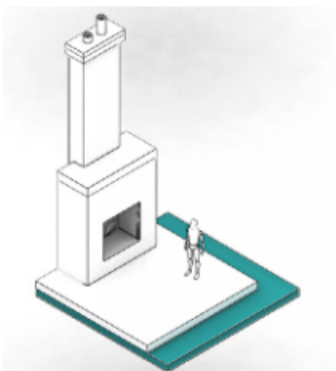

Living Deck

After the establishment of the farmyard and farmhouse, system support structures complete the agricultural production system, allowing the producer to focus on living systems for production. When viewed as a complete system, visiting consumers can fully interpret how the farm acts as actor within the rural network of production, responding to specific sites and ecologies. If the producer is available to explain the system in person, relating intricate details and experience to the passing consumer, human intimacy and empathy complete the shared experience of the rural process. The key consideration of the architecture is how to demonstrate simple construction systems in relation to a complex system of production. As each farm develops a unique value-add process and product in response to consumer need, industrial Hemp is revealed as a coagulant of vernacular process and sustainable agricultural production.

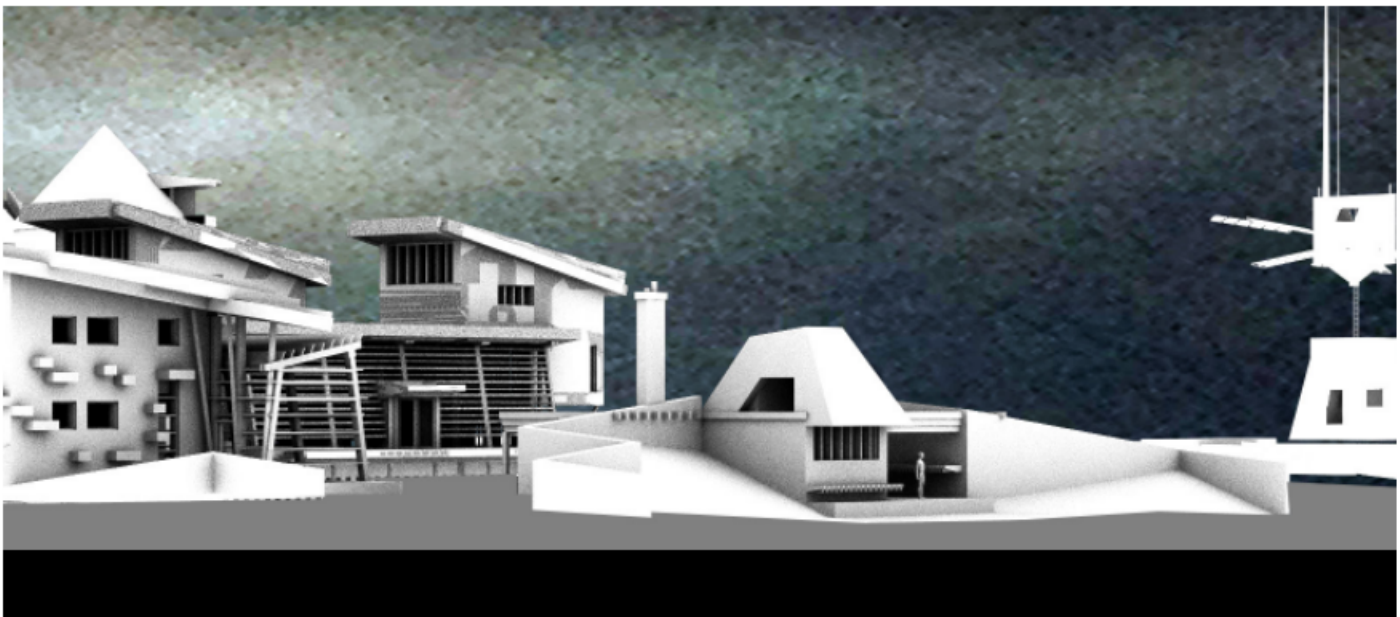



South East Perspective_Configured Farmhouse



North Perspective_Configured Farmhouse



West Perspective_Configured Farmhouse

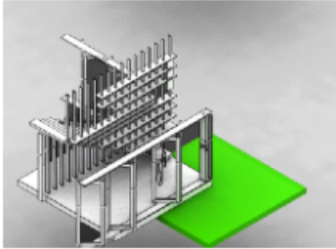

Internal Hall

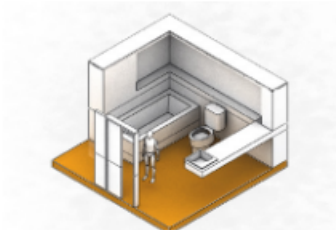

Bath Room

The revelation of the Configured farmhouse speaks to a reimagined material culture within Alberta's prairie landscape. When consumers are invited into the farmhouse, Hempcrete is revealed to fulfill many needs of the occupant, specifically, through the provision of a fully organic wall envelope that reduces energy consumption. It is in the interest of the rural producer to open their homes to consumers to relay their knowledge of sustainable agricultural production, and extend the opportunity to participate in that process. With regards to the contemporary divide of urban and rural systems that have allowed industrial agriculture to degrade our productive prairie landscape, individuals must treat the antonym of producer/consumer as an equal term. Equality must extend beyond the individual to the landscape and process that unites an organically balanced world. By concentrating rehabilitation to the residential portion of dwelling, producer and consumer alike may intersect a reimagined material culture.



Interior Perspective_Configured Farmhouse

WALKING BESIDE

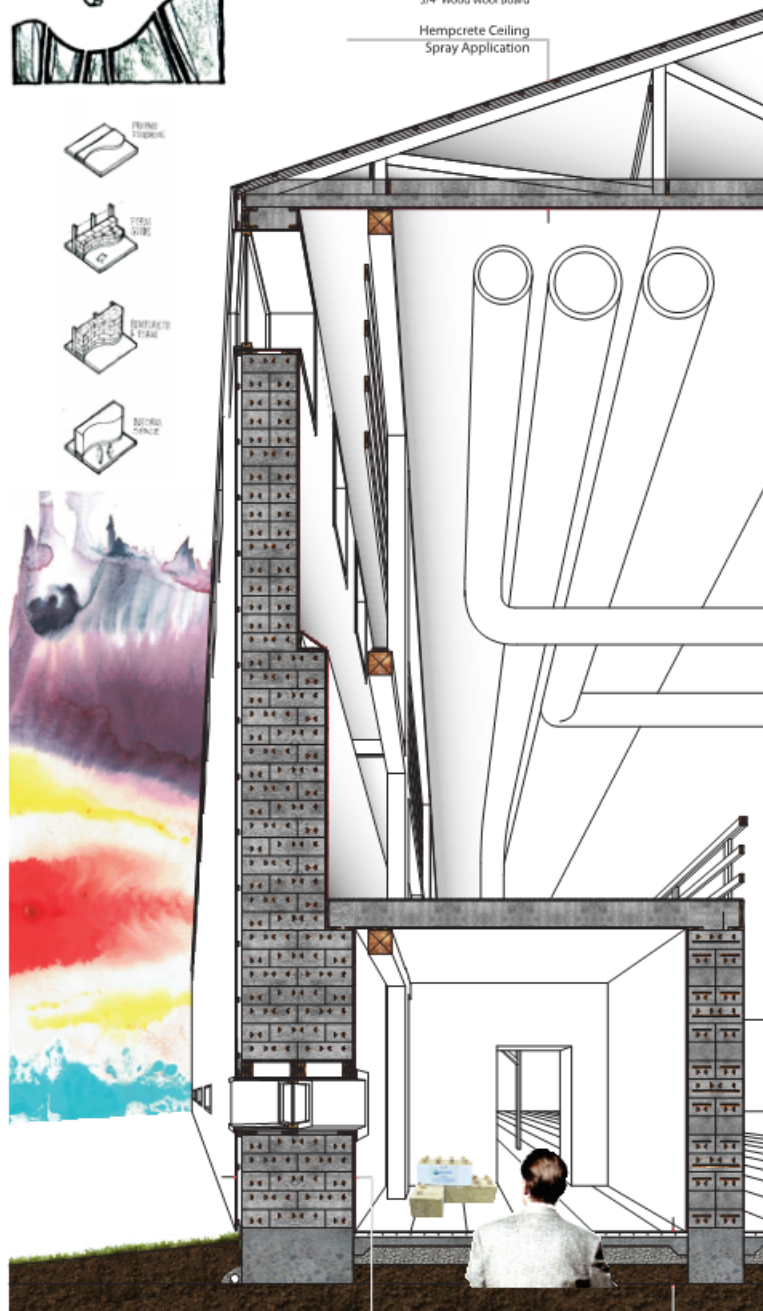

Prefinished Metal Sheathing
 2" x 2" Horizontal and Vertical Wood
 Battens, maintain 2" airspace
 T&G Wood Fibre Sarking Board
 2x6 Engineered Wood Frame Truss
 12" Hempcrete Ceiling Infill, **R25**
 3/4" Wood Wool Board

Hempcrete Ceiling
 Spray Application

Structural Hempcrete Block Wall

Prefinished Metal Sheathing
 2" x 2" Horizontal and Vertical Wood Battens
 Lime Cement Render Base Coat
 16" x 8" x 21" Super SSR Hempcrete Block
 3/4" Wood Wool Board

Floating Concrete Slab

Tile Floor
 1" Lime Cement Mortar Cover
 1/2" In-floor Heating Conduit
 6" Ribbed Concrete Floor Slab w/ Industrial Hardener
 6" Compacted Gravel
 6 mil PolyVapour Barrier
 Undisturbed Earth

JustBiofibre Structural Solutions

Super SSR Hempcrete Block
 40+ MPa (26 - 33 n/mm²) [compressive rating]
 .70 gm/m²/mmhg [air permeability]
 .23 gm/m²/mmhg [vapour permeability]

421 mj/m² [embodied energy]
 -17.6 kg/m²

Floating Concrete Foundation Wall

24" x 24" Reinforced Concrete Strip Foundation
 18" Reinforced Concrete Piles 8'-0" min. depth
 Weeping Tile w/ 6" min. Compacted Gravel cover

Hempcrete Typology #3_ Space Frame On Block

Work_Decortication Facility

To facilitate the establishment of a resilient rural process requires investment in the secondary and tertiary industries that support sustainable agricultural production. It is apparent that the progression of industrial agriculture was assisted by corporate agri-business; systematically removing the rural producer from the agricultural process by way of monetary capitalism. Resilient generational farms have persisted in spite of this, anchored by an ideal process of landscape sustainability, and through the partnering of like-minded individuals that coalesce on social, economic, and cultural planes. The vision of establishing the new rural process of industrial Hemp production in Alberta hinges on the ability of the facility to become a community actor within a rural network. As such, the decortication facility must grow with the availability of producer skill and resource, demanding incremental development of process, building, and community engagement to ensure its integration into rural systems.

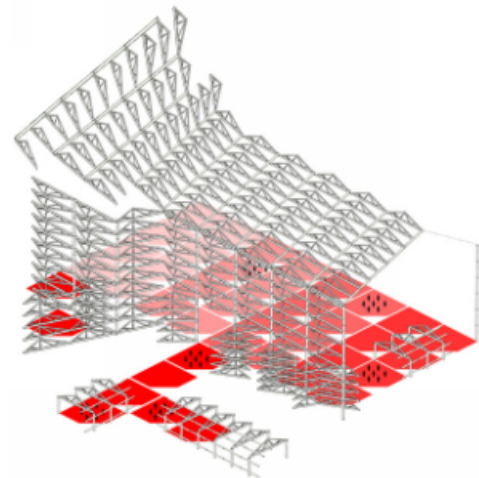
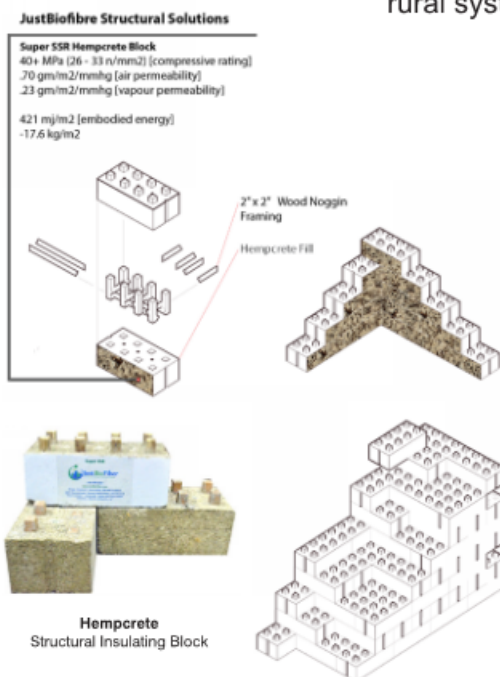

Agricultural and industrial buildings rely on simple structures to create large interior and re-programmable workspaces. The culture of industry is labour, and the division of exterior from interior environment.

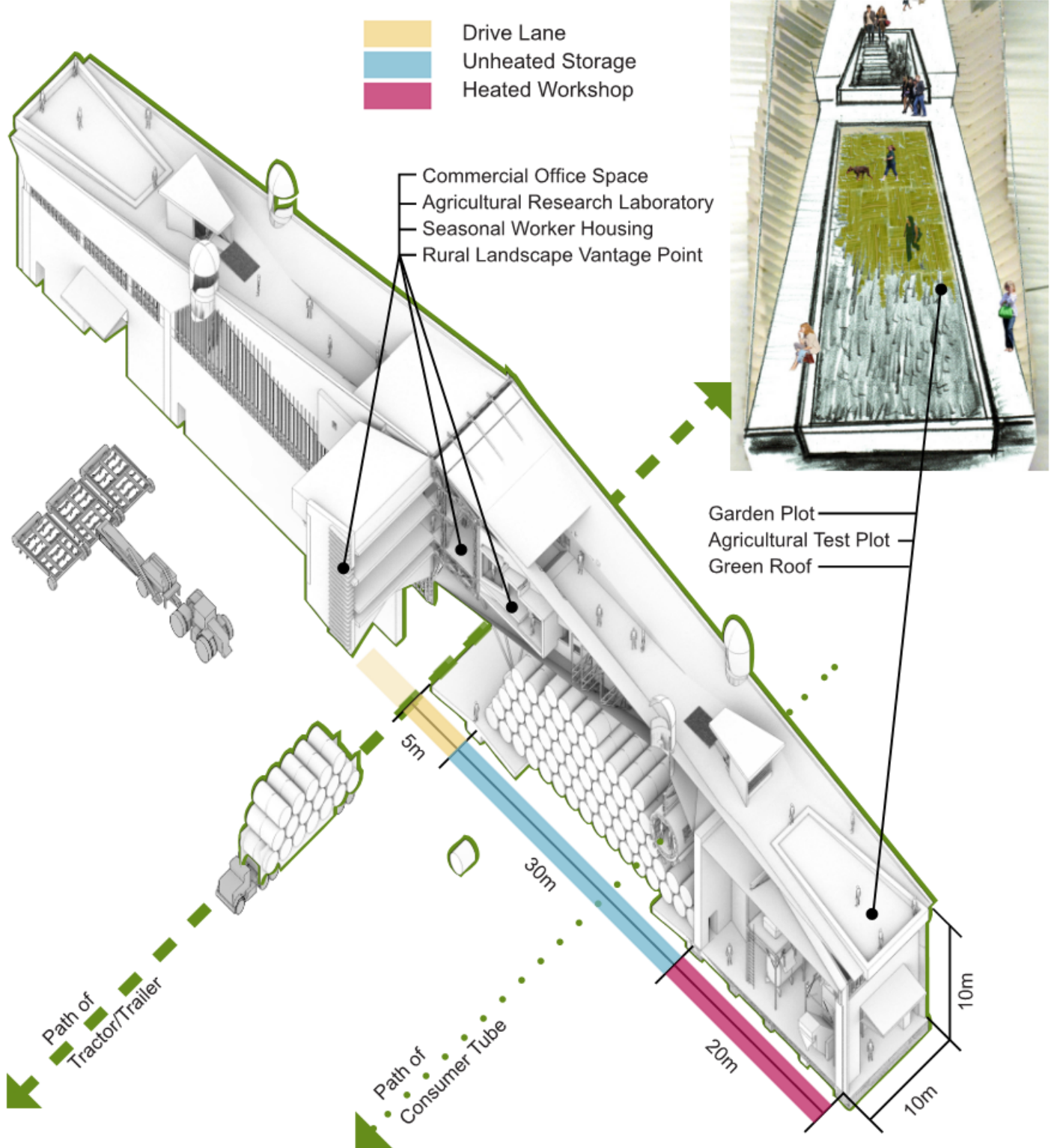

An industrially scaled Barn suitable for any agricultural, industrial or commercial process. Using economical and sustainable building materials in coordination with Low-Energy building principles and Renewable Energy co-generation, the Hempcrete barn allows young farmers to begin their value-added agricultural process the right way.

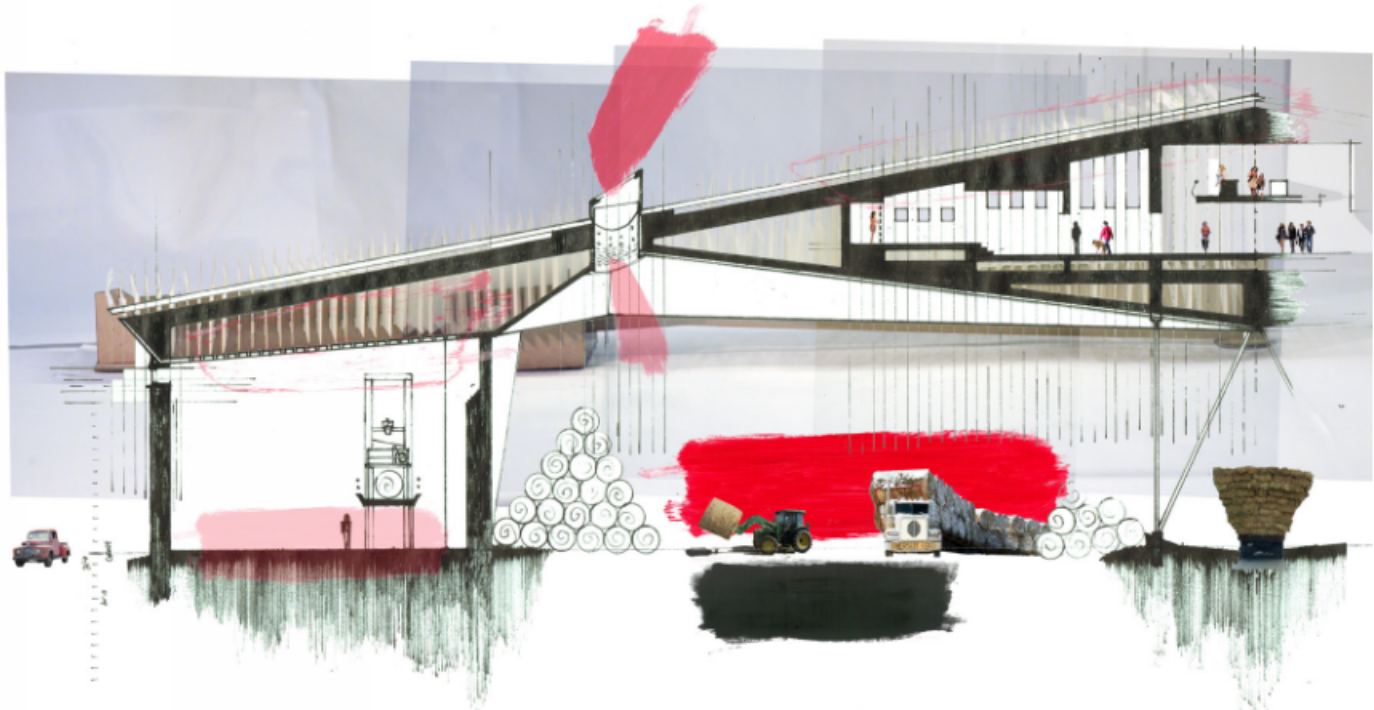

Bunkhouse

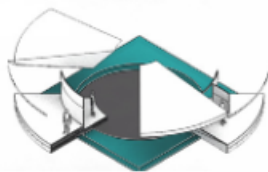

Lookout



Workshop

To reduce the massive capital investment into such an ambitious project, and to simplify the design process, the architect-planner-entrepreneur will focus on creating an inclusive barn design that meets the producers needs for raw material storage, interiorized production halls, and human scaled dwelling. The Hempcrete Barn Module was developed to create an industrially scaled agricultural building that demonstrates the potential for sustainable design at every scale. To assist the development of a vernacular construction language, structural elements of the barn module are intended to be assembled at human scale, and affixed at an industrial scale. Programmatically, the barn module is a simple assemblage of non-heated and heated interior space which allows rural producers to work in every season. Foremost, the barn module is intended to be replicated at production sites of rural producers to store raw material to preserve quality and assist local process. As demand requires, raw agricultural materials are transferred to larger processing facilities.

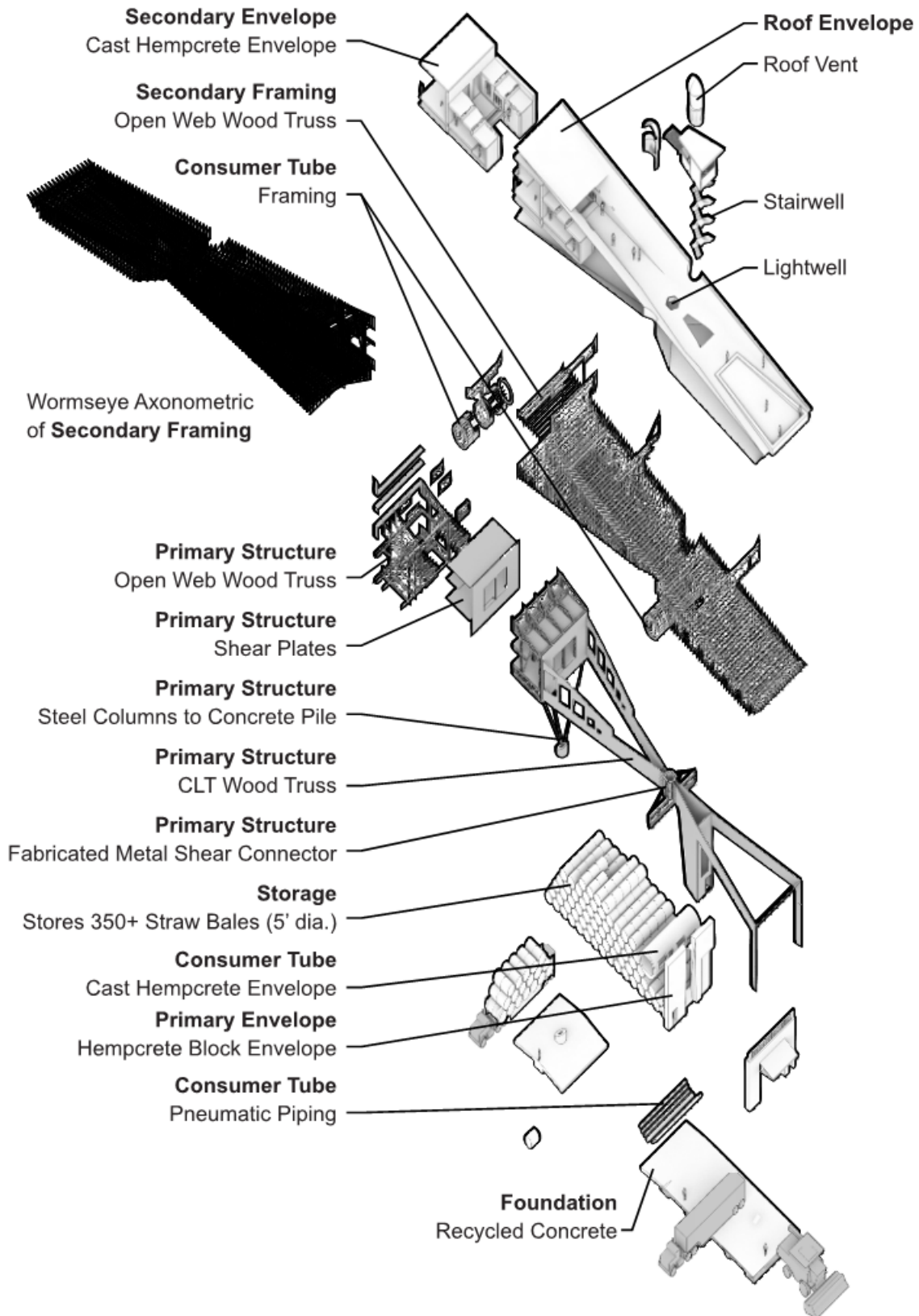

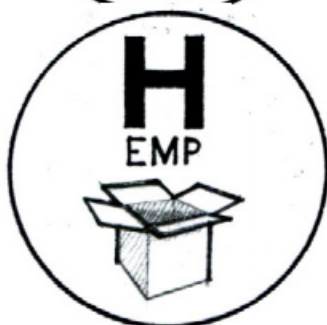
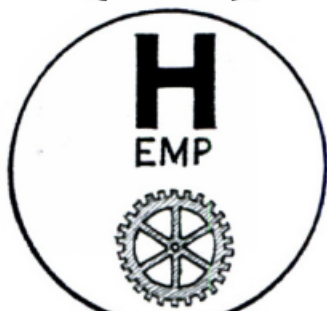

In an effort for material sustainability, structural materials are primarily wood and the wall envelope is Hempcrete. The Hempcrete wall is made from structural Hempcrete blocks, sourced from an Alberta company Just Bio Fibre Structural Solutions, a sustainable Hemp product that shares the mechanical properties of structural concrete.¹⁰⁴ CLT beams are assembled piece by piece at grade and lifted into position to create a cantilevered long span beam overtop the cold storage barn. A structural steel bottleneck splices the individual CLT beams into single structural piece to create an inhabitable roof deck, supported at one end by columns triangulated to a single foundation pile to increase accessibility at grade. The roof surface is created through the manipulation of successive open-web wood trusses that span across the intersecting CLT beams.

Occupants access the roof level by a stairwell located in the central column of the CLT beam, an approved fire rated construction. Above the heated workshop, a greenroof counterweights the cantilevered roof structure, providing a productive surface for agricultural research or garden plots, depending on the associated programming of the upstairs dwelling. Roof vents, nicknamed 'chickenheads', move with the wind direction to effectively ventilate the cold storage barn below and maintain a dry condition for the continuous Hempcrete envelope that covers the entire roof surface. Where possible, structure is made inhabitable to increase functionality and provide a more holistic agricultural and industrial building typology to rural producers. If needed, warm and cold programming can be alternated to create

104. Just Bio Fibre Structural Solutions. "Home." Last modified August 16, 2016. <http://justbiofiber.ca/>

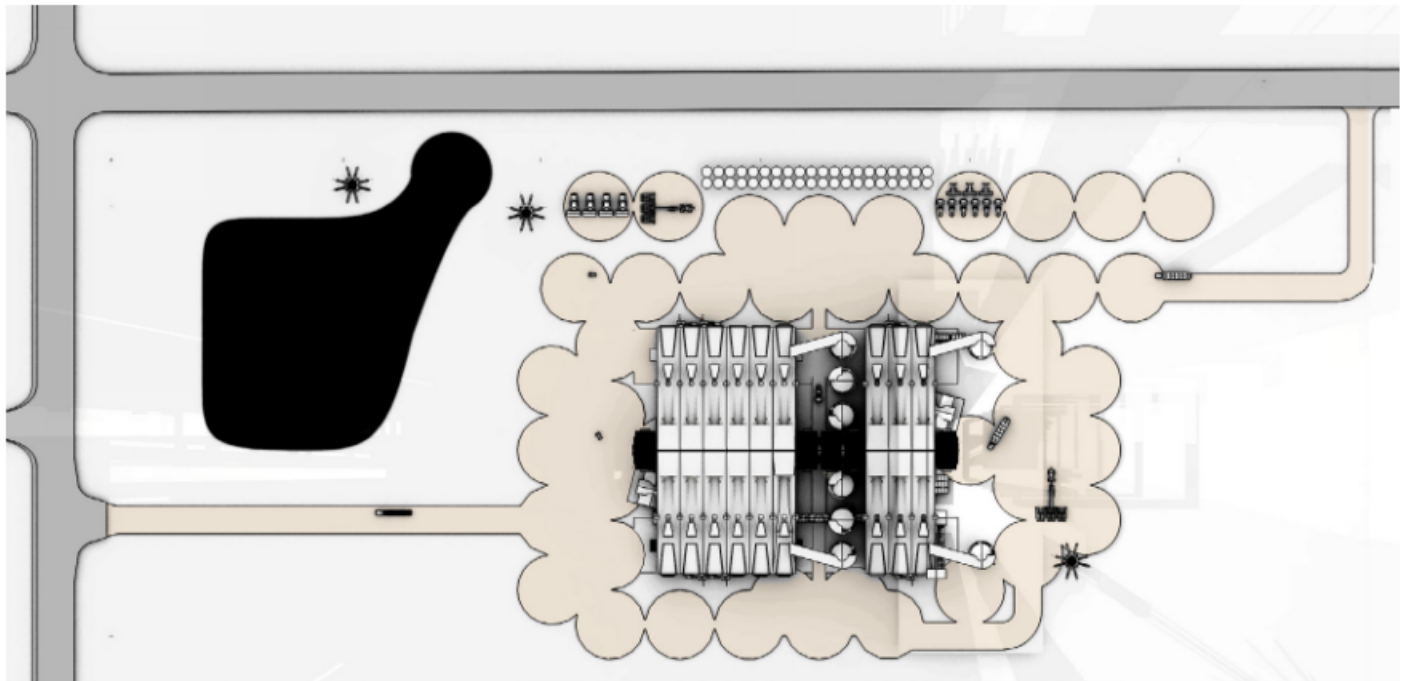

Site Plan_Study Site 1 and Decortication Facility

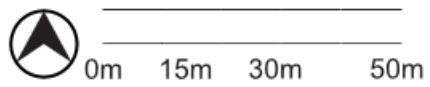
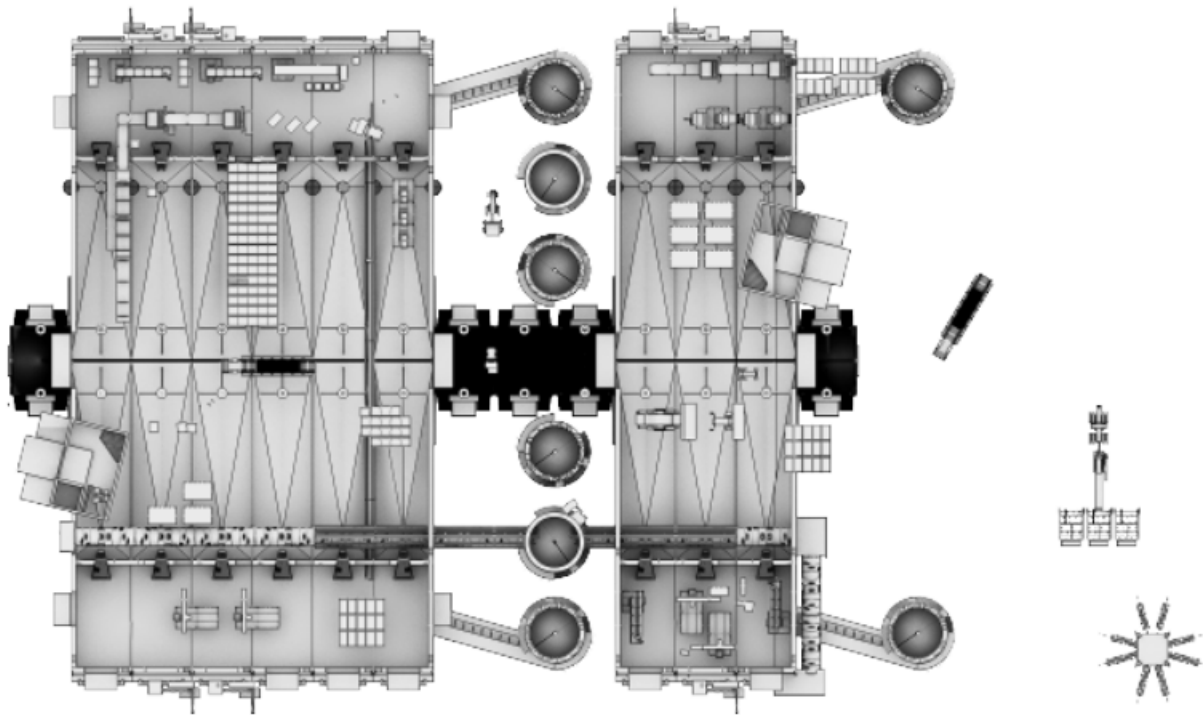

Wormseye Ground Floor Plan



Garage/ Workshop



Home Office

variations of the assembled Hempcrete barn.

When fully realized, the HempWorks Local Decortication Barn sits at the northern extent of Study Site 1, directly accessed from Highway 857 or Warwick Rd. Building assemblage consists of six Hempcrete barn modules, mirrored on a West by East axis, that creates the main processing and storage barn. An alleyway separates an additional three modules to allow for direct deposit of processed material into adjacent Granaries and breaks the massing of a large industrial building. The three module barn holds secondary processing and the sustainable material depot that rural producers can directly purchase construction materials, or pre-assembled Hempcrete construction systems. Offices correspond to human scale at the West and East extents of the facility.

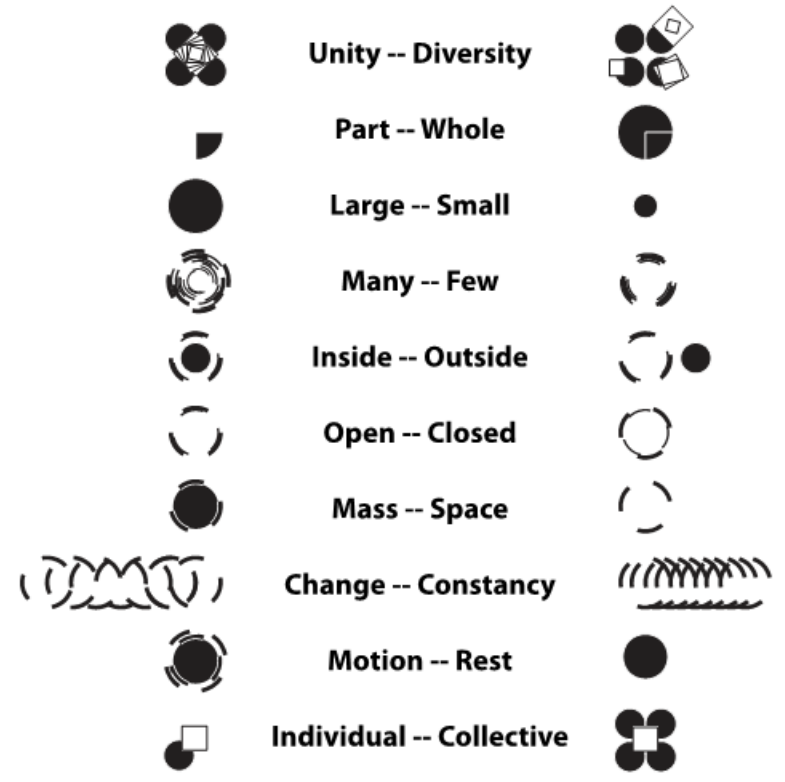
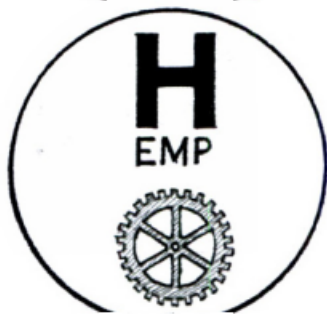

Reciprocal Antonyms for Design

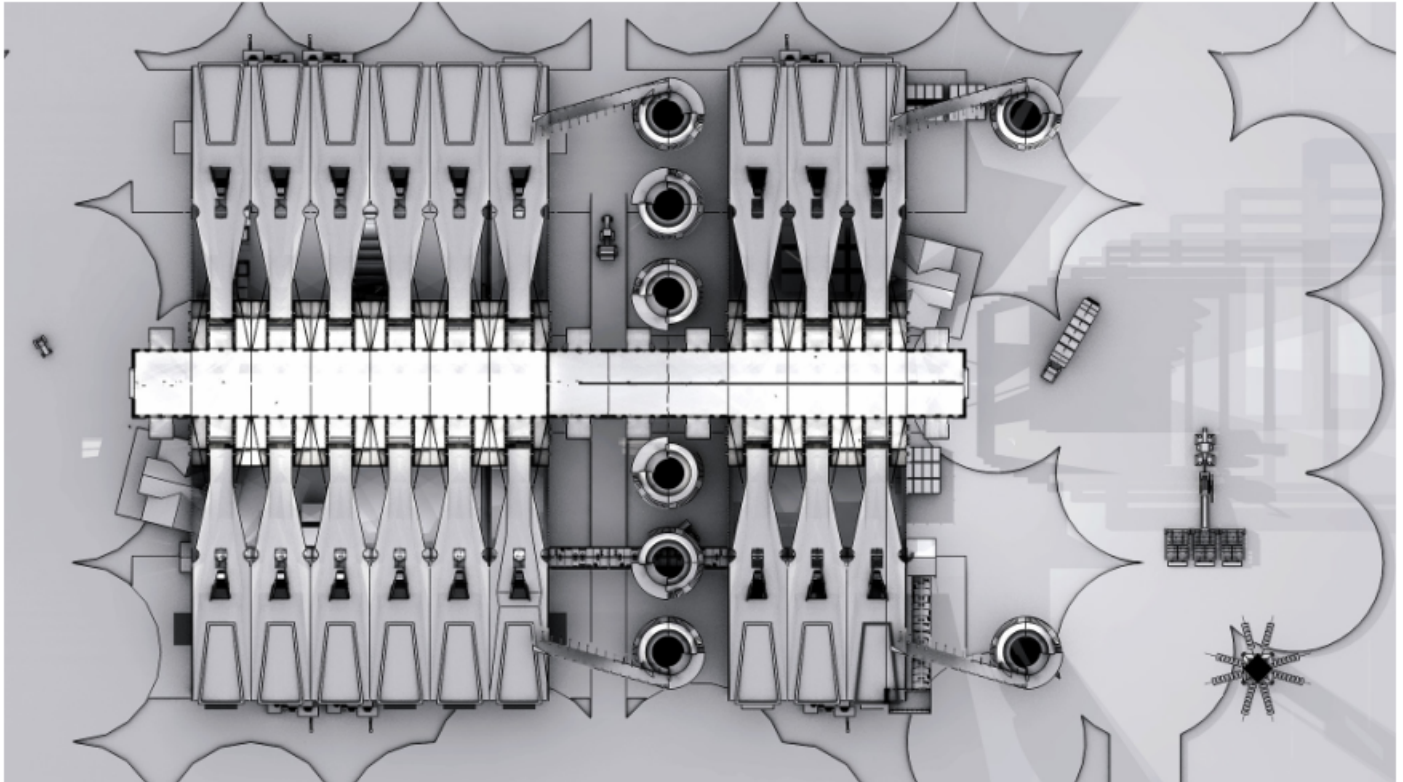

Barn Loft Floor Plan

The top floor of the Hempcrete Barn Module can be programmed as bunkouse apartments for seasonal labourers, permanent employees, an agricultural research and development laboratory, or a commercial office space - in consideration of adaptive reuse.

Expanding the dwelling surface of the Hempcrete Barn into a vacant roof cavity provides a unique vantage point over the rural landscape and directly coincides with the agricultural process below. Designed as a reiterative assemblage of simillare pieces, this inhabitable roofs mimics sod houses that were buried into the rural landscape for additional warmth. The fully developed Hempcrete Barn Module roof represents a lifted productive surface that utilizes heat stack to reduce energy consumption.

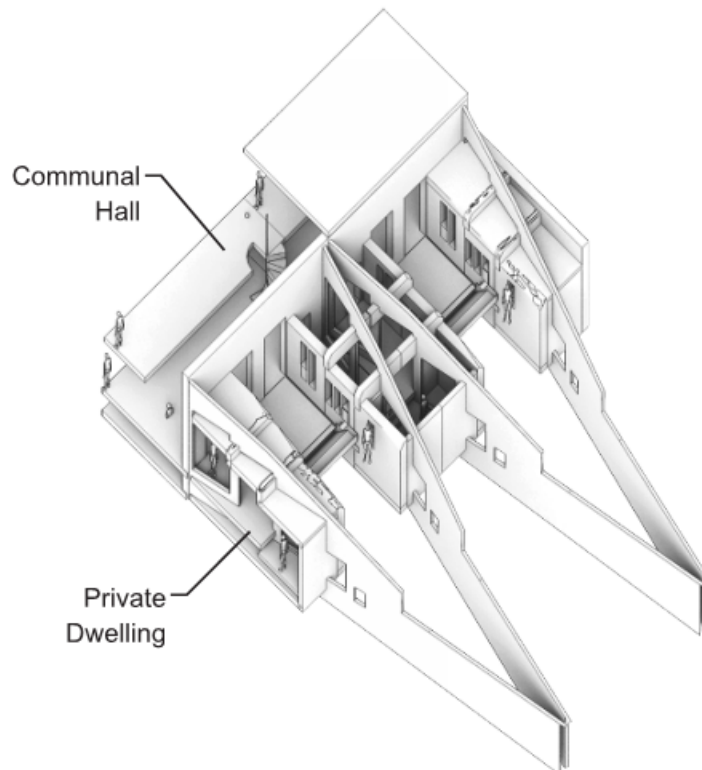

Barn Lofts Birdseye Axonometric

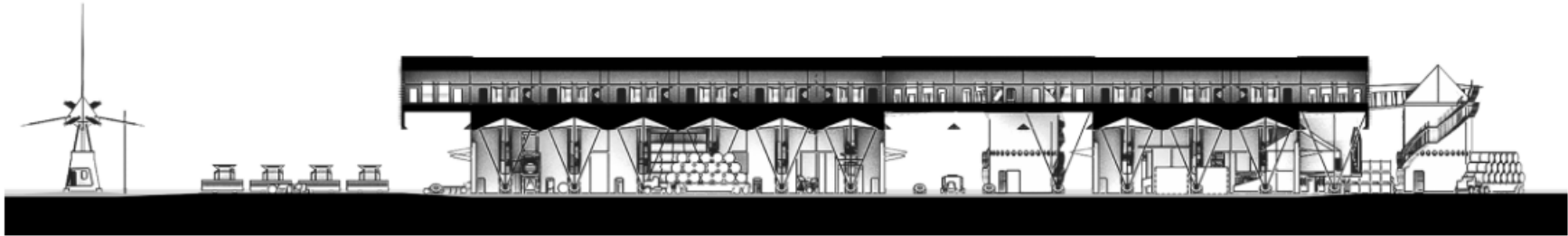

West by East Building Section_Hempworks Decortication Facility_Looking North to Cold Storage Barn



East by West Building Section_Hempworks Decortication Facility_Looking South to Consumer Tube through Cold Storage Barn



East by West Building Section_Hempworks Decortication Facility_Looking South to Decortication Equipment through the Heated Workshop.

- Drive Lane
- Unheated Storage
- Heated Workshop

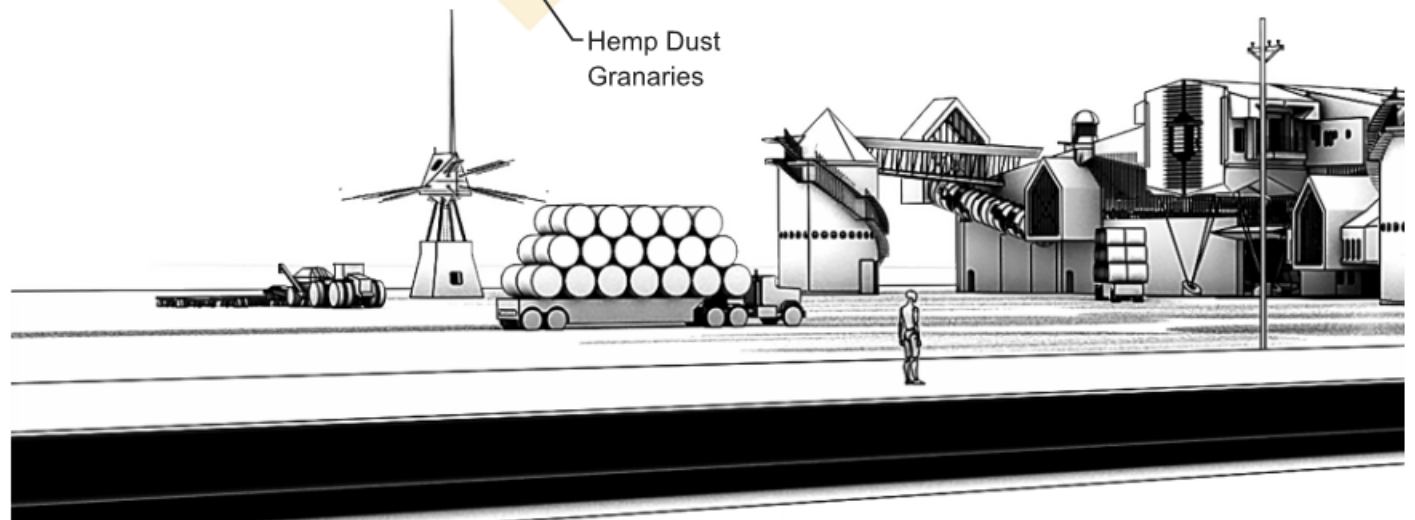
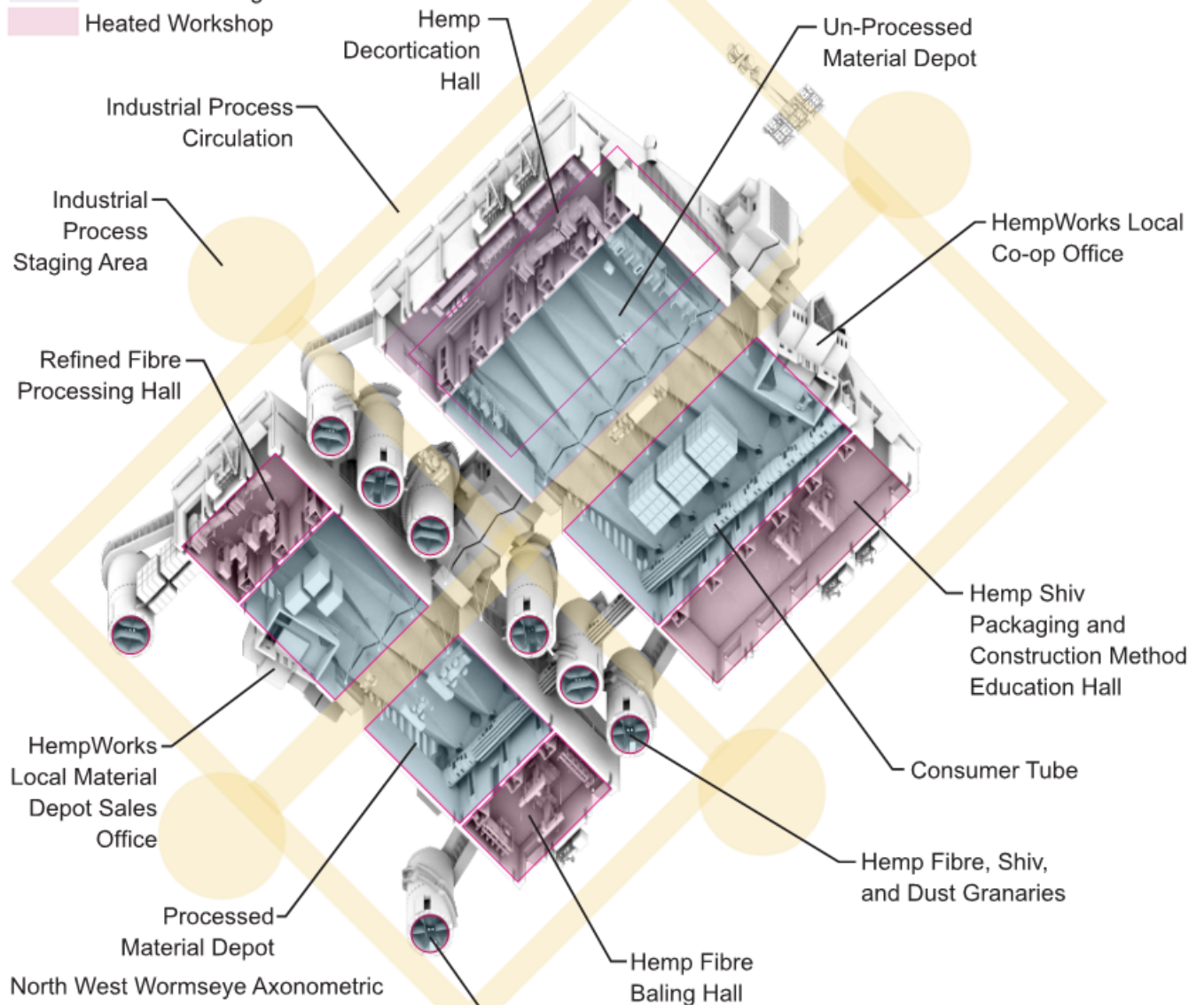

North West Wormseye Axonometric

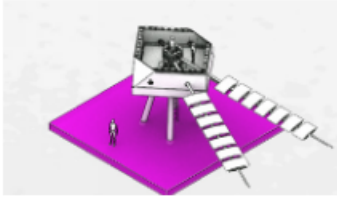

Renewable Energy



Landscape Features

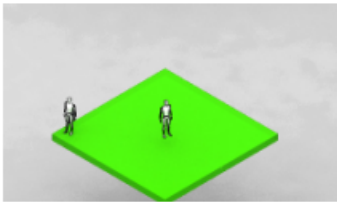

Natural Landscape
Community

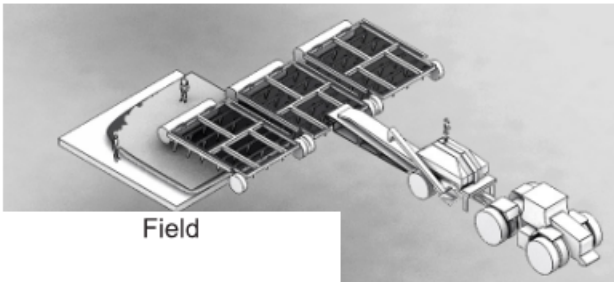

Field

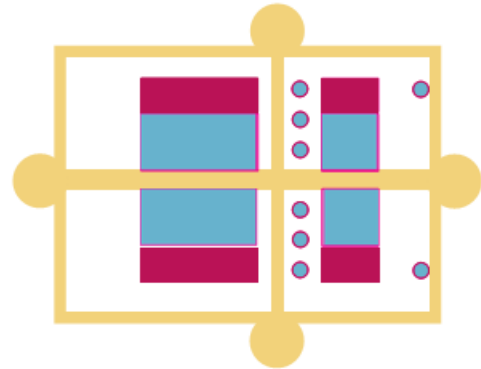

Industrial Program Parti

Programmatically, the HempWorks Local Decortication Facility is a simple resonance of the agricultural process that focuses on the development of resilient community processes. To facilitate a Hemp network will require the provision of Hemp education, tutorials, and custom farming services that assist and affirm a local Hemp agricultural process. As well, the facility will host construction seminars that teach local producers to build with Hempcrete and other sustainable building materials. Not only does HempWorks provide the local producer with new skills, but also provides new employment opportunities for local industry. Building beyond the HempWorks barn, additional Hempcrete Barn Modules become leasable work spaces for

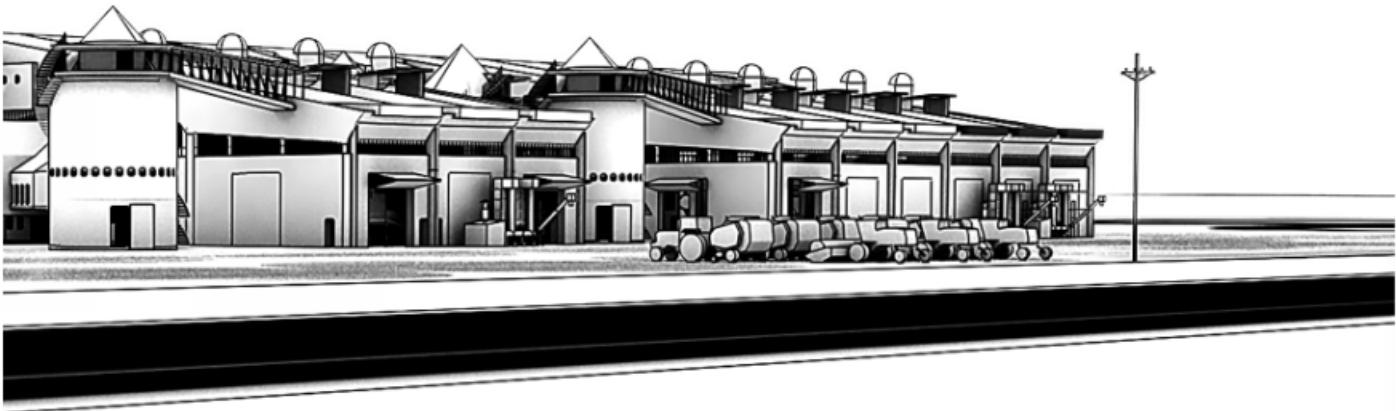

North East Perspective

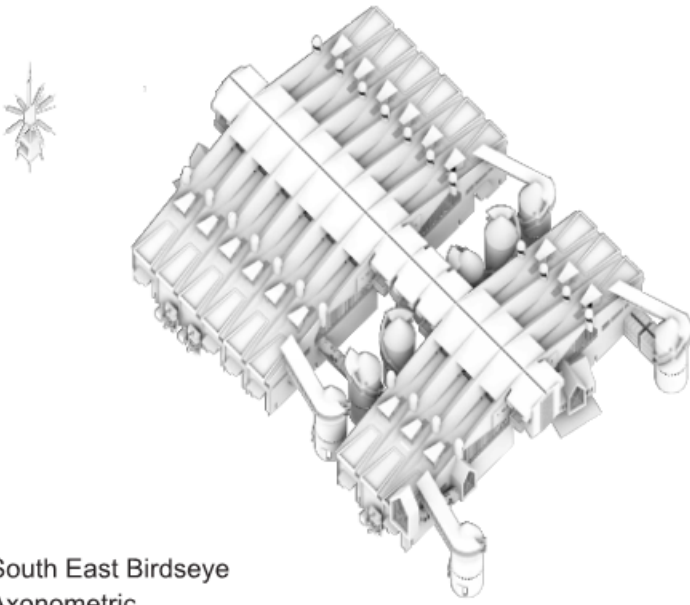

South East Birdseye
Axonometric

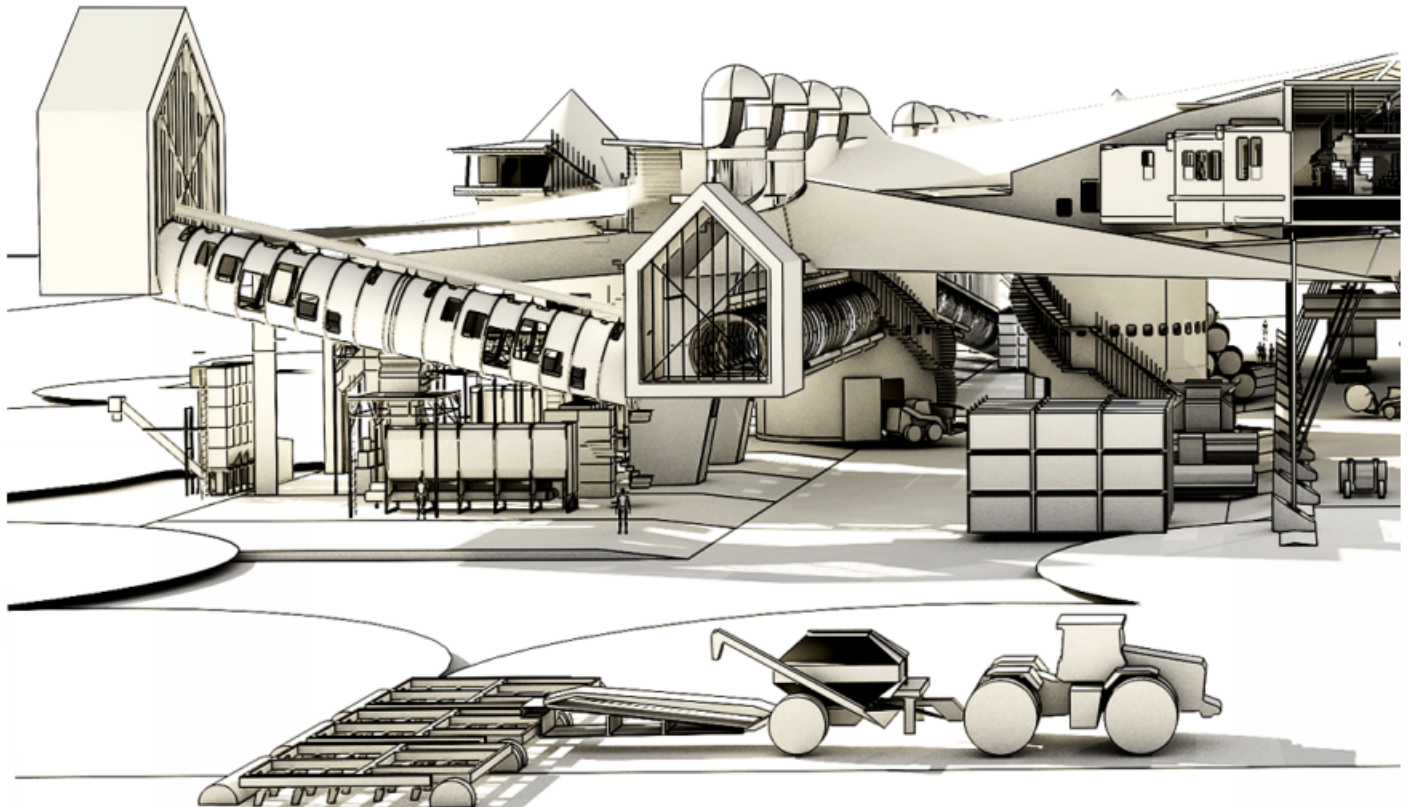

Multiplicity at Play.

Many systems operate in-sync to produce an effective agricultural process that reflects producer effort. Organized to accommodate any need of the producer, the barn module is an additive and associative building process. Additions like the consumer tube provide the immersive learning experience that catalyzes rural process in the consumers perspective.

Individual



Producer/ Consumer

local producers that wish to develop biofire products.

Given the scale of the building and the necessary separation of residential and industrial space, the HempWorks Local facility cannot be fully experienced from one vantage point or process. Instead, the integration of the Consumer Tube facilitates the procession of visitors and potential franchise developers to learn the Hemp decortication process and experience intimate moments of personal learning. Consumers are moved in a linear procession from grade to roof, turning at moments where dormer rooms necessitate views onto the rural landscape and resilient community process.

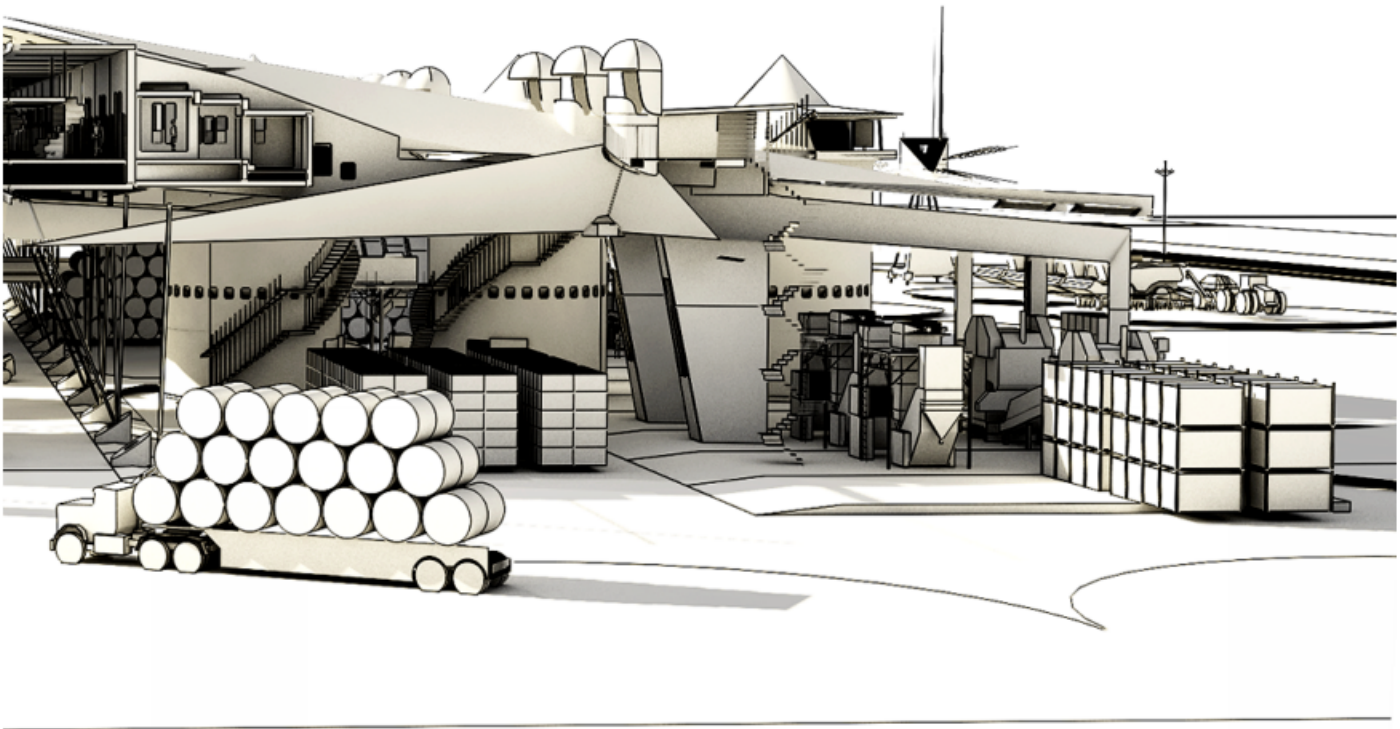

East Perspective of Decortication Facility with Hempcrete Walls removed.



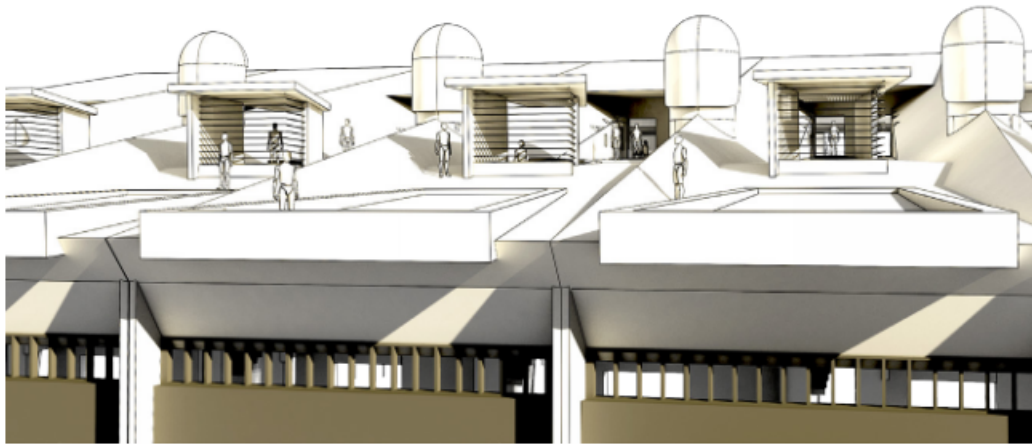

Exterior Perspective_Hempworks Decortication Facility_Greenroof, Garden, or Testplot?



Interior Perspective_Hempworks Decortication Facility_Cold Storage Barn



Exterior Perspective_Hempworks Decortication Facility_Shop Doors



Interior Perspective_Hempworks Decortication Facility_Shop Doors



Bunkhouse

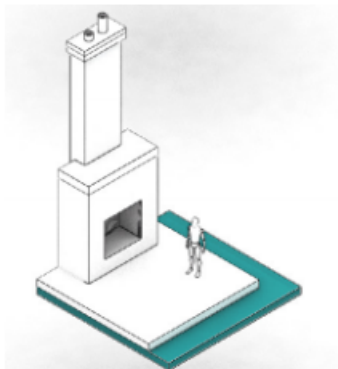

Living Deck

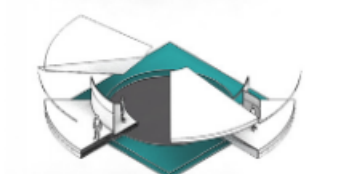

Lookout

To reduce building materials and create an aesthetically dramatic built form, the Hempcrete Barn Module features an undulating roof surface of flat planes. Where possible, Hempcrete creates the floor, wall, and roof surface to continue the peripheral experience of natural building material. In creating industrially scaled interior and exterior oriented workspaces at grade, the second storey reciprocates by providing the residential scale. A proponent of community is proximity to neighbours, allowing for the dissemination of ideas and knowledge, and culminates in the top storey, or street, of the Hempcrete Barn Module.

RESIDUAL FORM



Prefinished Metal Roof
 2" x 2" Horizontal and Vertical Wood Battens, maintain 2" airspace
 T&G Wood Fibre Sarking Board [vapour permeable]
 2x6 Wood Frame Truss
 12" Hempcrete Ceiling Fill, **R25**
 12" Engineered TGI Wood Rafter @ 24" o.c.
 3/4" Wood Wool Board, Permanent Shuttering

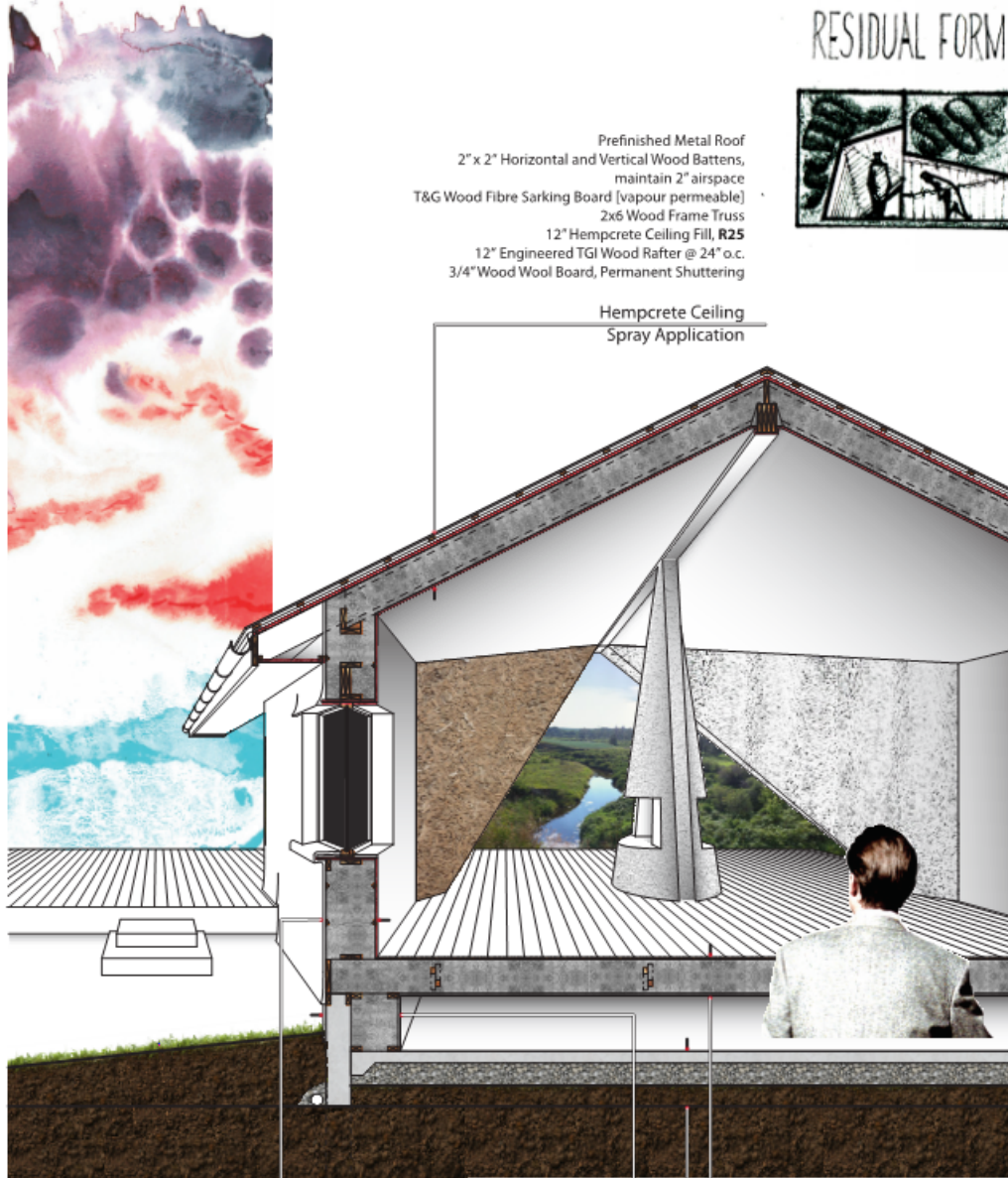

Hempcrete Ceiling
Spray Application

Hempcrete Wall
Spray Application

Plenum Hempcrete Floor
Spray Application

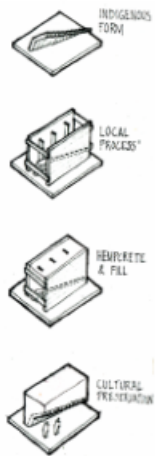

1" min. Lime Cement Exterior Render
 Lime Cement Render Base Coat
 16" Hempcrete Wall Fill, **R33, .458 MPa**
 2x6 SPF Wood Framing @ 16" o.c.
 2"x2" Triangular SPF Wood Noggins, both sides

3/4" Hardwood Plank Flooring
 2x12 SPF Wood Floor Joists @ 16" o.c. w/
 2" x 2" Diagonal SPF Wood Bridging
 12" Hempcrete Floor Infill, **R25**
 3/4" Wood Wool Board
 Heated Airspace

Foundation Wall

1" Cement Parging to ext. face of block wall
 8" Reinforced Concrete Foundation Wall
 8" Floating Concrete Piles, 8'-0" min. depth
 SBS Membrane, liquid applied
 8"x16" Concrete Strip Foundation
 16" Hempcrete Wall Fill, **R33, .458 MPa**
 2x6 Wood Framing @ 16" o.c.
 3/4" Wood Wool Board
 Weeping Tile w/ 6" min. Crushed Gravel Cover

Reinforced Floating Concrete Slab

4" Concrete Slab
 6 mil Poly Vapour Barrier
 2" Recycled Foam Glass Block
 6" Compacted Gravel
 Undisturbed Earth

Hempcrete Typology #4_ Residual Form on Space Frame

Play_The Community Hall

The Configured farmhouse demonstrate sustainability at a residential scale, and the Hempcrete Barn Module the industrial scale - the scales commonly associated to the industrial agricultural process and generational family farm. The architect-planner-entrepreneur must find resolution of the consumer experience at the commercial scale. Designing for reciprocity requires the resolution between previously disparate antonymns, scale, and process with the objective of creating a more holistic understanding our present lifestyles. As is obvious, the modern consumer is selfish in their propagation of material wealth and experience. What happens when those consumers are exposed to community values that require the consideration of complex material production systems.

Using architecture as social and cultural leverage, rural communities can recapture the attention of the urban consumer and refocus their interests to associative agricultural landscapes, products, and processes. By creating a community hall entrenched in an established, or budding, generational family farm will catalyze the resilient rural system as an opportunity for the urban consumer to Learn, Live, Work, and Play in the Alberta prairie landscape.



Hempcrete Interior Wall - Plaster



Hempcrete Wall -Spray Application

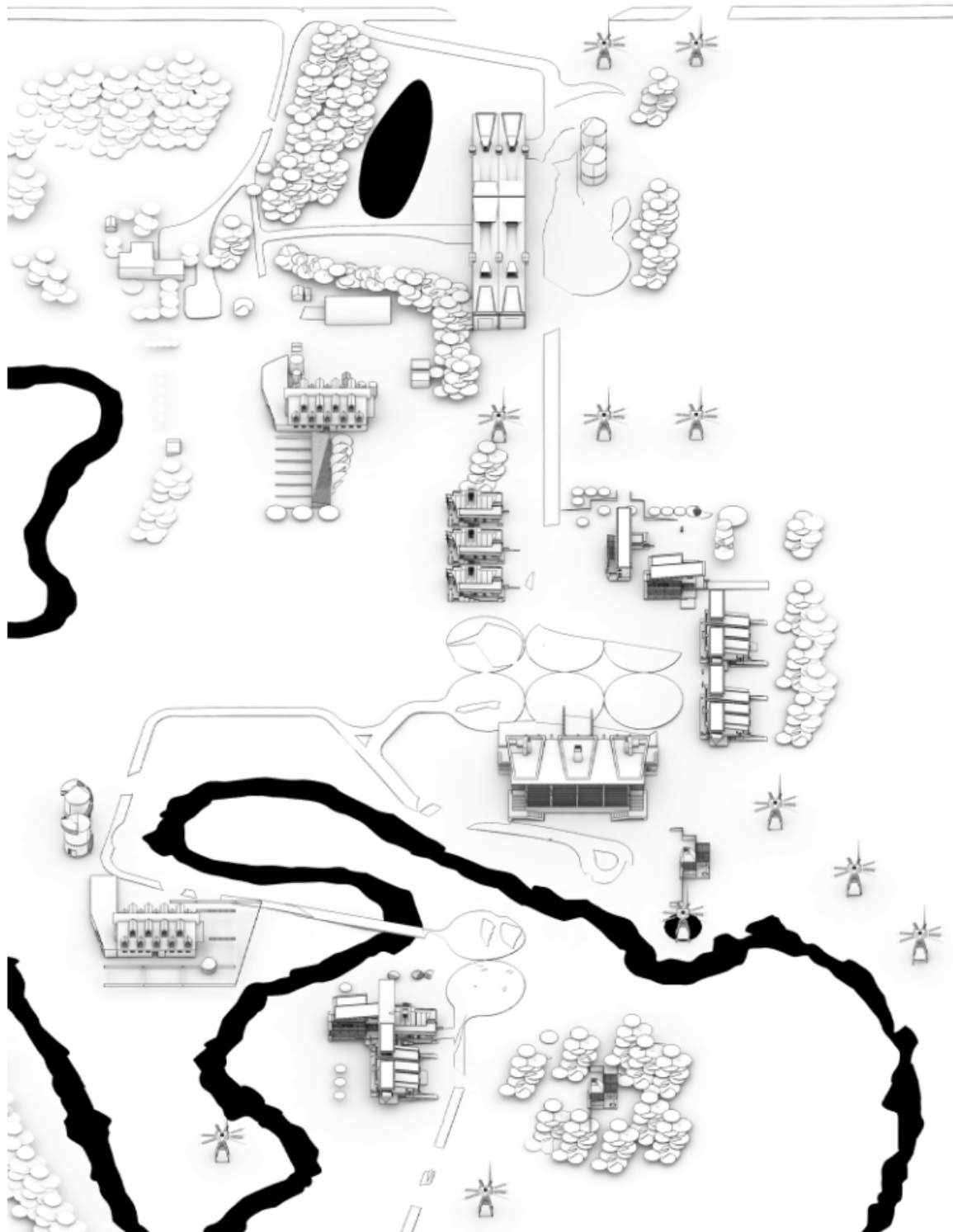

The Community Hall is a Value-Add generational farm process wherein a family farm manages a social and cultural venue. Programmatically, the hall functions as local Farmer's Market, dance and music hall, catered restaurant and Town Hall. As density is low, multiple programming that focuses attention onto the natural beauty of the Prairie landscape is vital to catalyzing the consumers experience.



Bunkhouse

Individual



Producer/ Consumer

Community

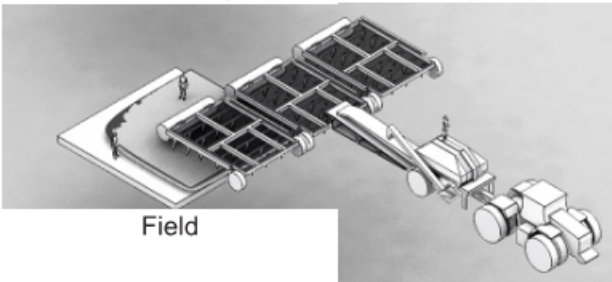

Field



Renewable Energy

The Community Hall is a Value-Add generational farm process wherein a family, or multiple families, manage a social and cultural venue for the rural and urban community - the commercial interface between the urban consumer and the rural producer. Programmatically, the hall interchangeably functions as local farmer's market, dance and music hall, catered restaurant, and town hall. As rural density is sparse, multiple consumer programs that focus attention onto the aesthetic beauty of the prairie landscape is critical to catalyzing the consumers experience. The built form of the Community Hall is non-intrusive upon the prairie

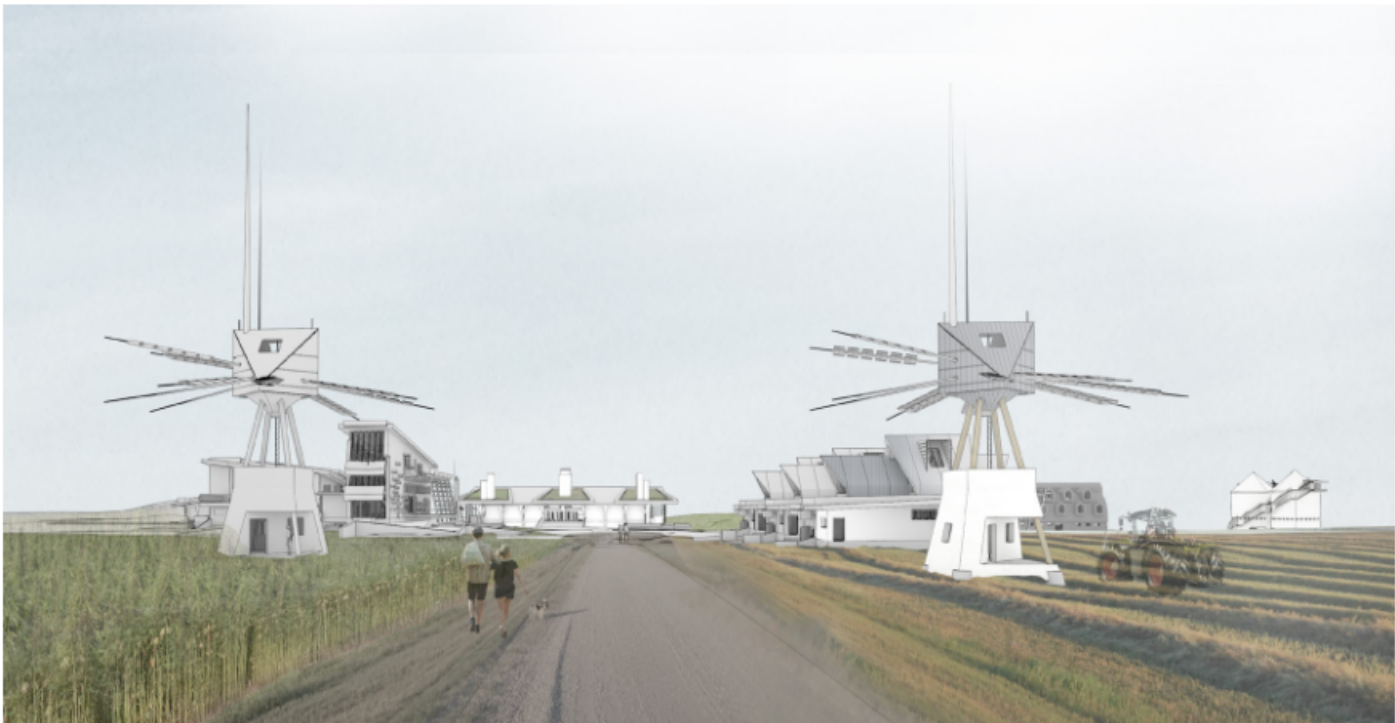

Exterior Perspective_Community Hall_Moment of Arrival

324

Occupants: **20-320**

Floor Area: **1500 m²**

Hempcrete
Building Envelope: **900 m³**

Estimated Cost of
Hempcrete: **\$ 105570**

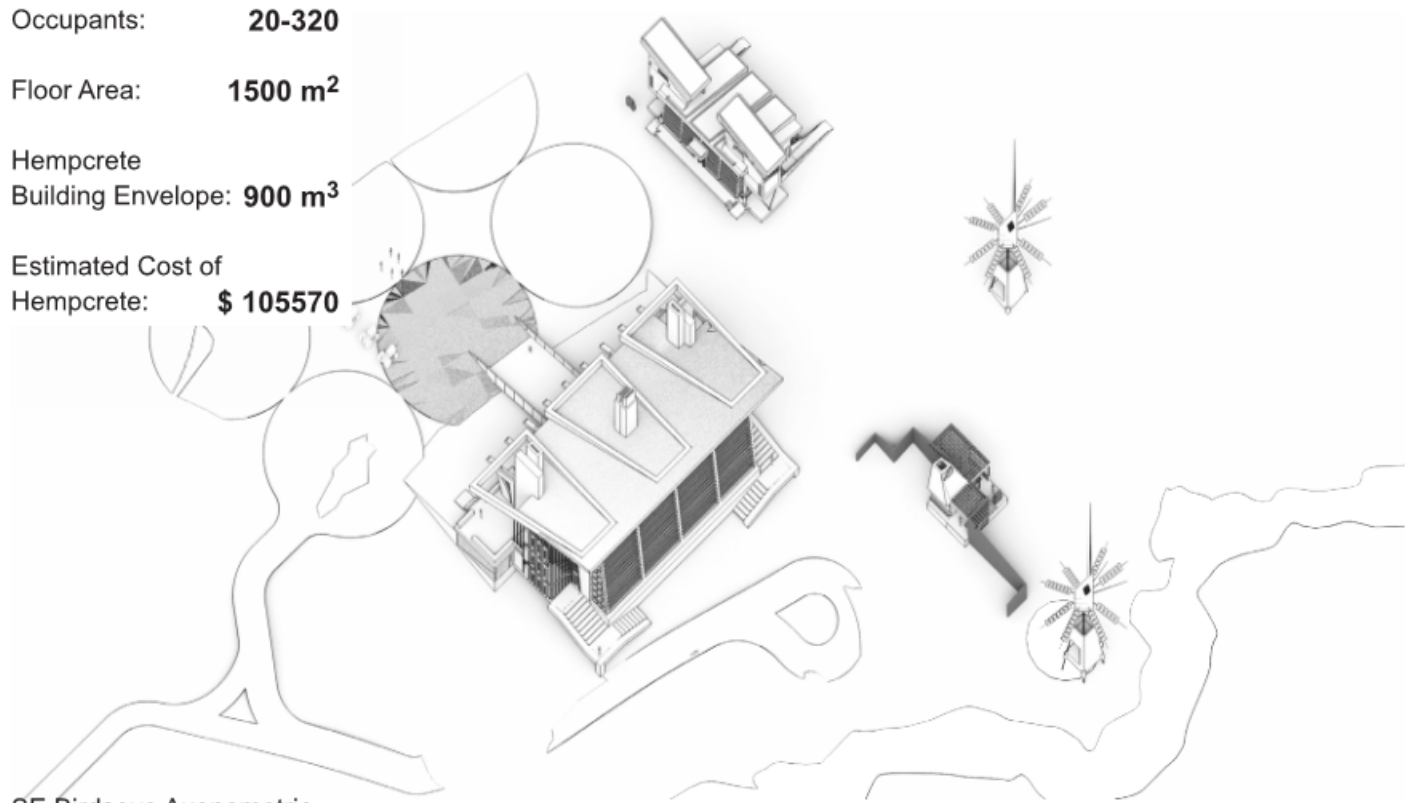

SE Birdseye Axonometric

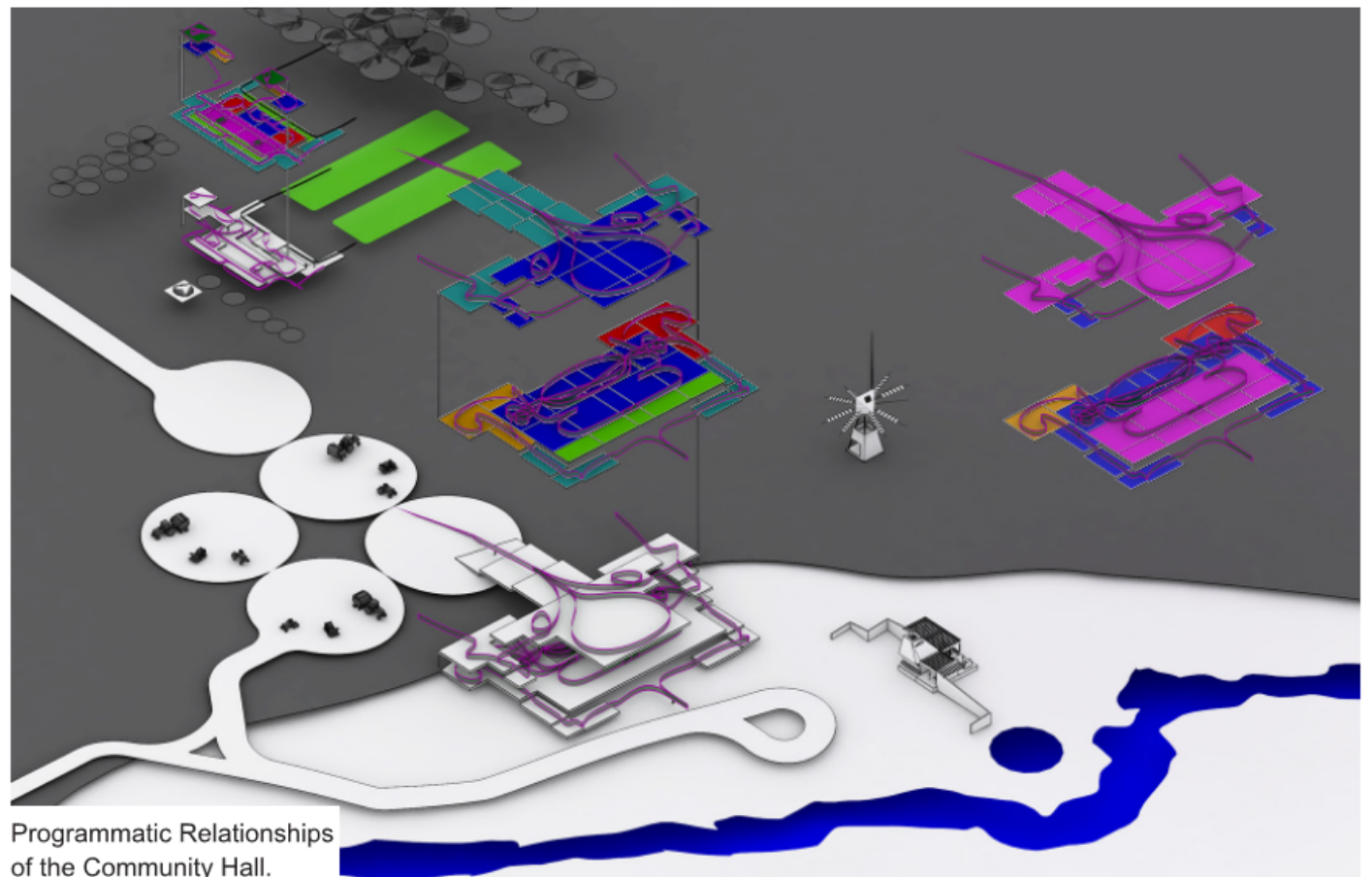

Programmatic Relationships
of the Community Hall.

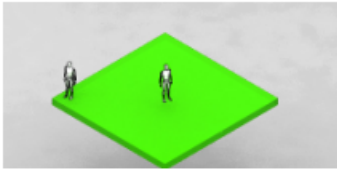

Natural Landscape

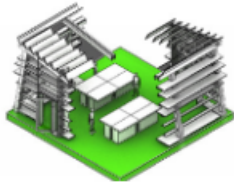

Commercial Greenhouse

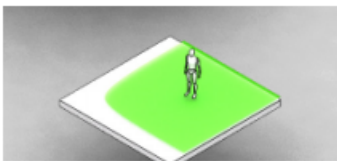

Farmstead Garden

landscape, dug into a steep embankment that overlooks an intermittent river to the East.

Visitors approach from the West, passing a Hempcrete Barn Module, RE-Towers and an assortment of Hempcrete farmhouses which express the aesthetic beauty of a sustainable rural community. These farmhouses, set directly into the existing productive surface, are intended for intermittent consumer inhabitation and rural lifestyle exposure. Monumental chimney's rising from the greenroof of the Community Hall are reminiscent of prairie grain elevators. Utilizing sustainable design principles reduces overall costs of maintaining such an operation, and lends to the resilient community process of disseminating rural experience. As urban and rural families inhabit the farmhouses and experience the Community Hall, they interiorize personal moments of dwelling in a rural community - strengthened by the sharing of experience with close family, friends,



Exterior Perspective_Community Hall_Rural Cottage Community

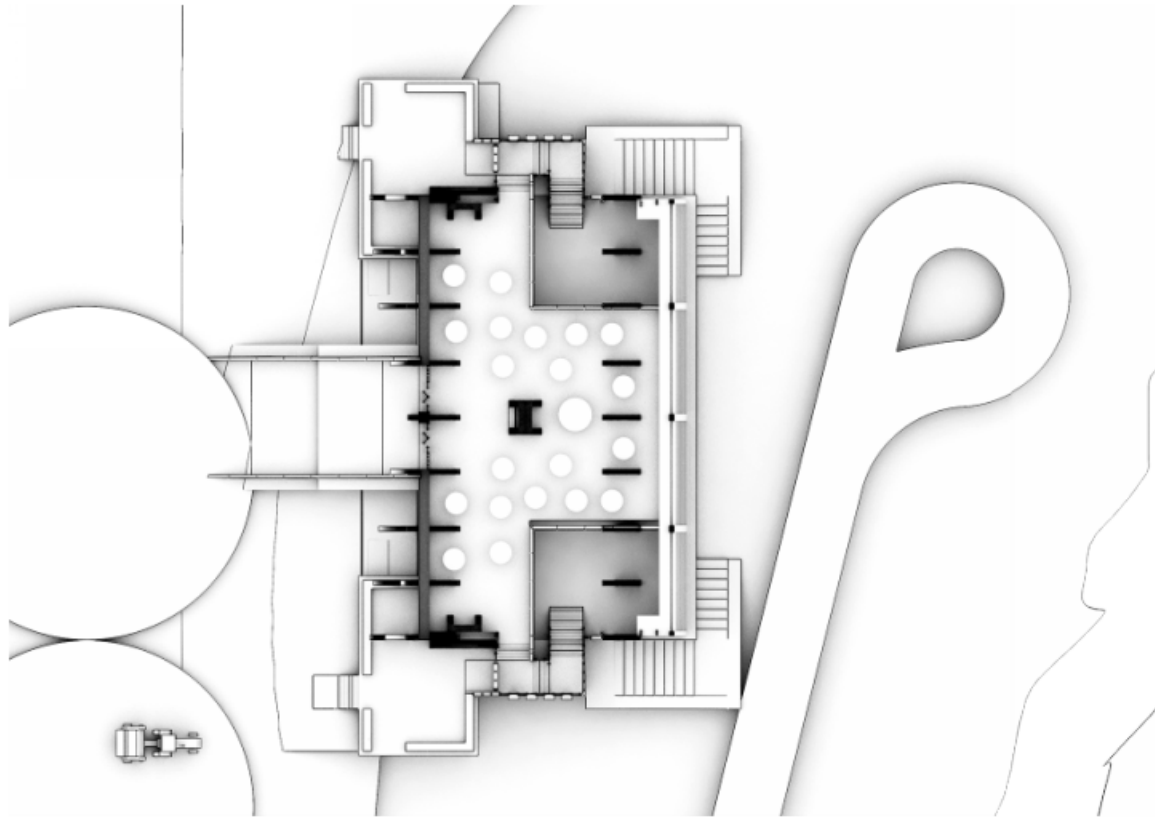

Second Floor Plan

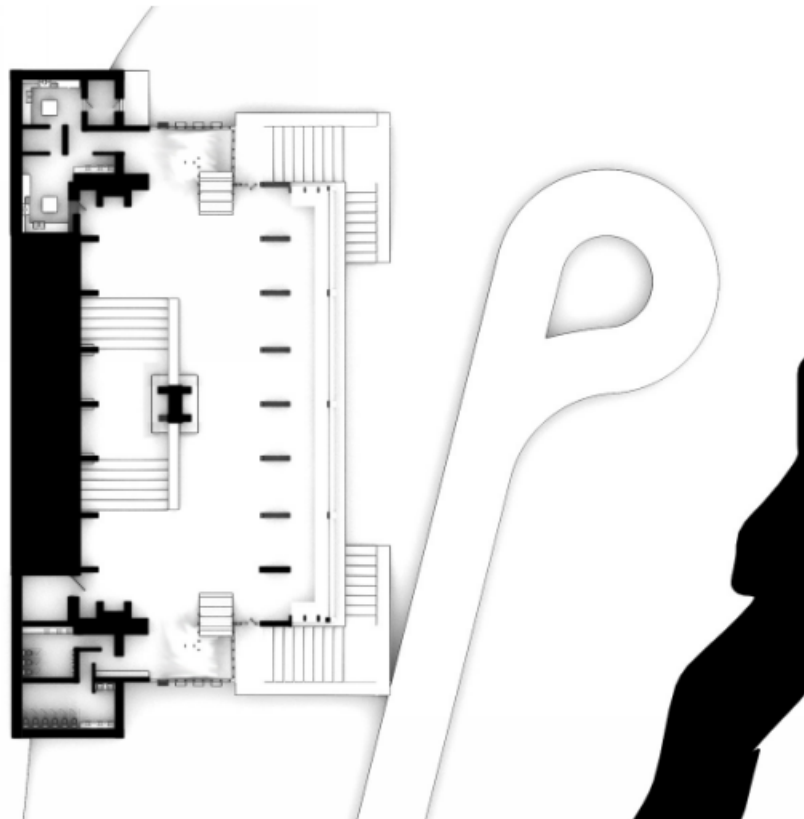

Ground Floor Plan

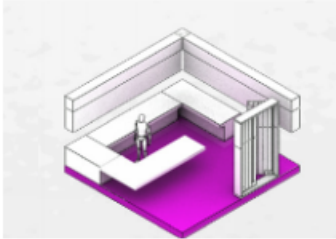

Events Office

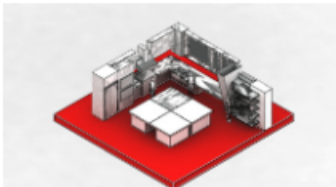

Commercial Kitchen

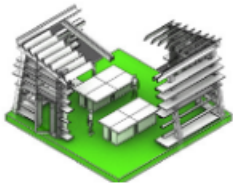

Commercial Greenhouse

neighbours, and so on. When those moments coalesce with greater life celebrations, like weddings, they become a permanent revelation in the perspective of the consumer.

Programmatically, and aesthetically, the Community Hall is modelled after the Greenhouse, exploiting scale of built form to replicate personal association. A long ramp connects a gravel parking lot, the staging area for events relating to the agricultural process. Visitors enter the second storey mezzanine that serves as dining hall, with access to the ground floor by widened stairwells, doubly serving as social platforms between floors. The Groundfloor serves as dance hall, separated by a low massing wall that shades a sunken seating area at the back of the West wall, half buried

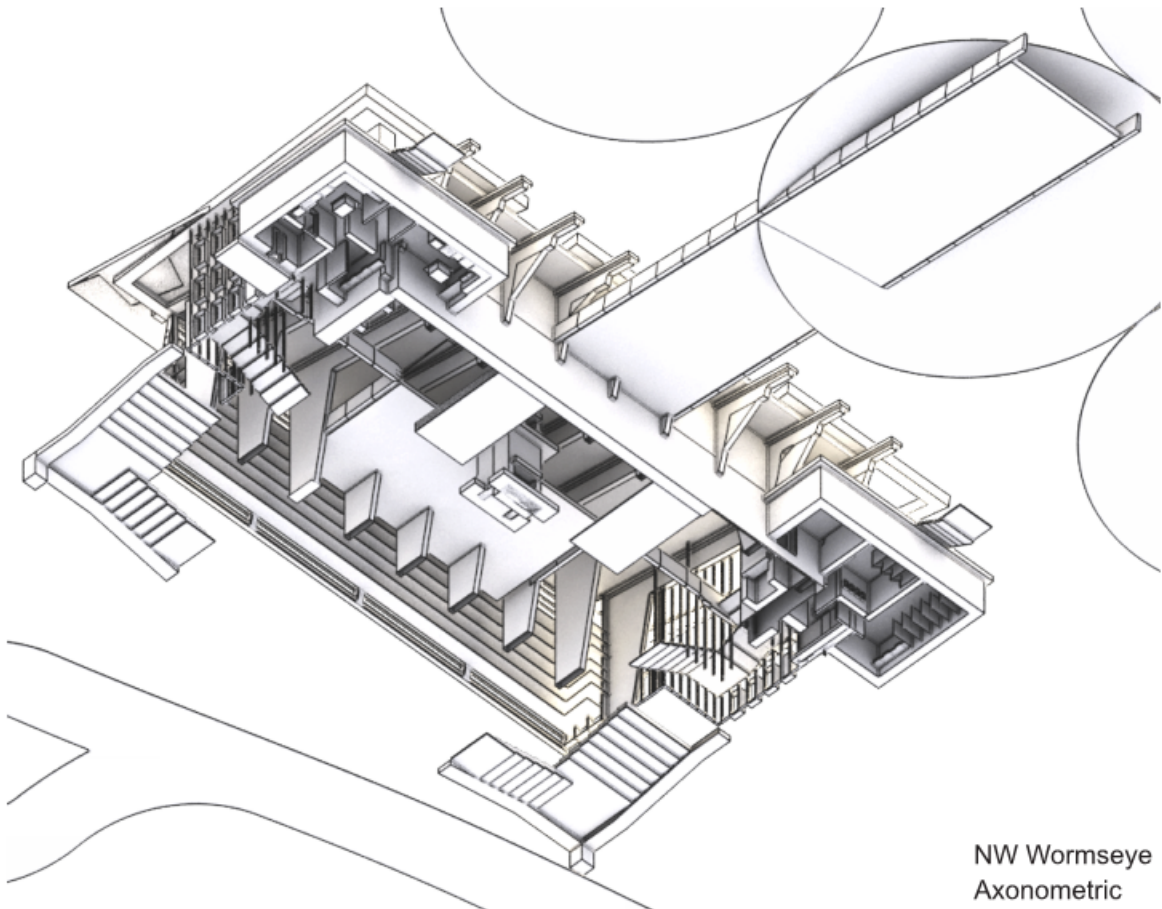
NW Wormseye
Axonometric

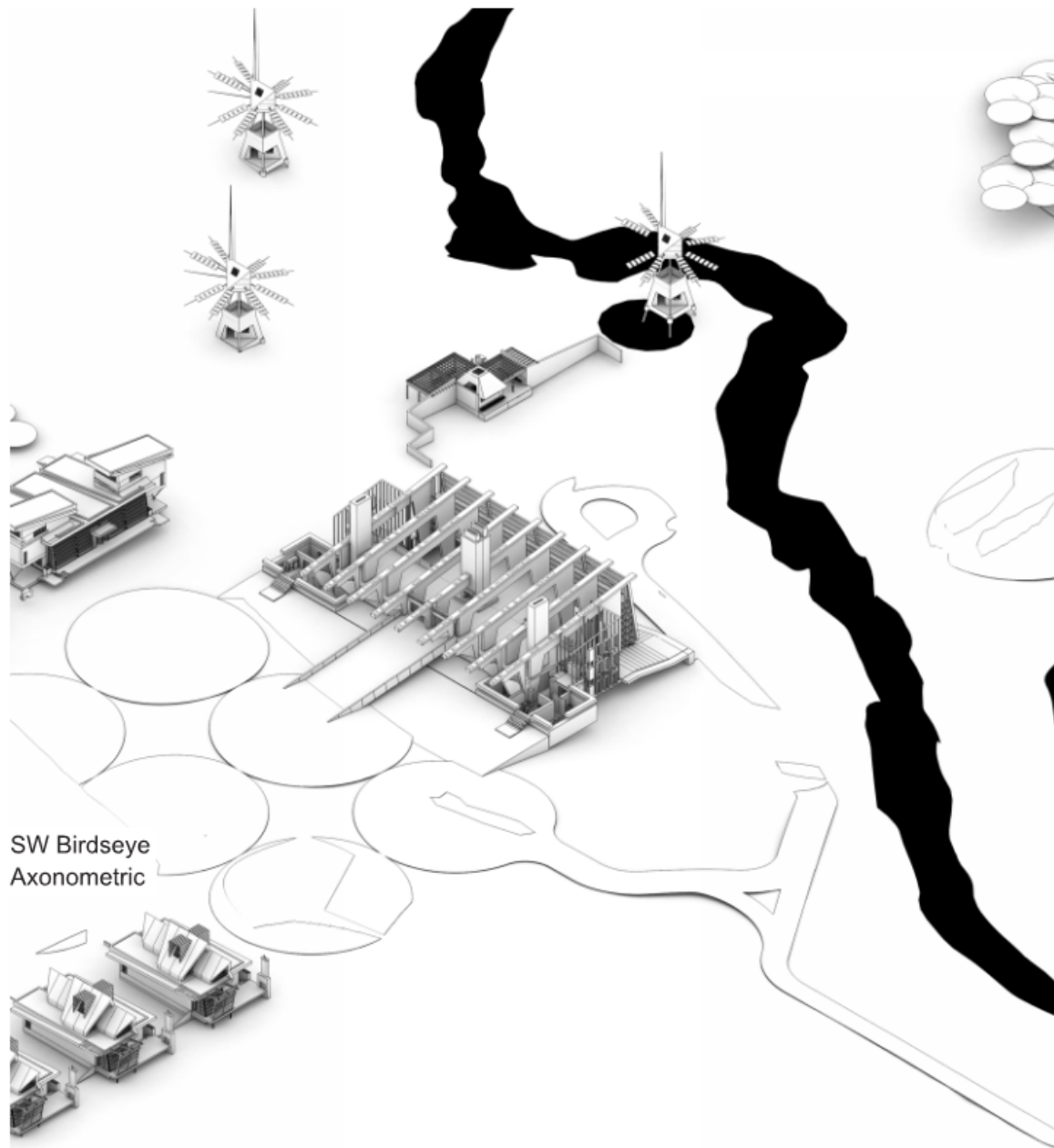

SW Birdseye
Axonometric

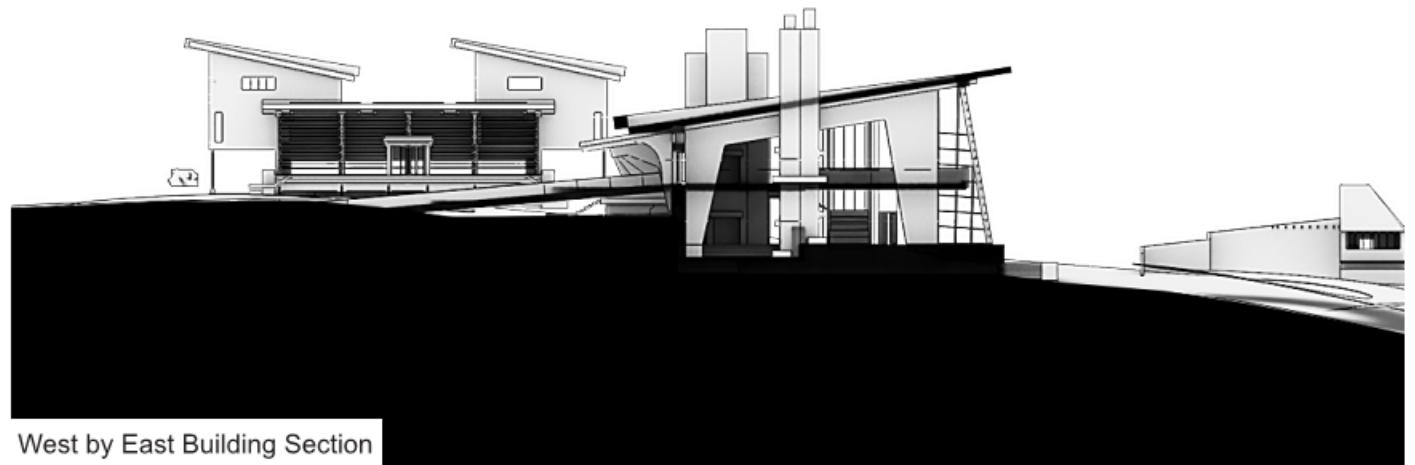

West by East Building Section



Landscape Features

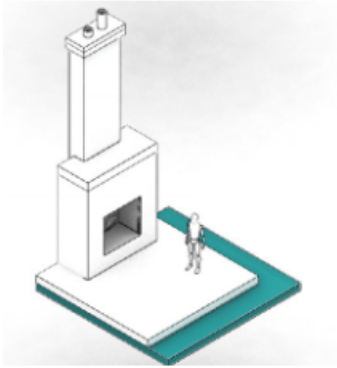

Living Deck



Hot Tub



Bannock Oven

in the hill bank. The East wall is full height glazing, shielded by continuous, horizontal shelving that serves as display wall, or living wall, for locally produced agricultural products. Views from the Community Hall are oriented to the North, East and South landscape onto the Vermillion river as it snakes through the landscape, revealing a rolling prairie landscape and the intersection of natural environmental process with the rural producer process. Building services consist of a commercial kitchen at the Northwest corner of the building, and bathrooms in the Southwest corner, opening the East face of the building to the riverbank.

Because rural producers primarily exist in the exterior, the Community Hall utilizes the riverbank as exterior room, loosely programmed between the access road and the Smokehouse. Across the river, a generational farmhouse hosts the caretakers family, accessed by private road from the South, or, by an access road that crosses a bridge and connects to the Community Hall after passing the producers livestock pens and Woodshop Barn. Greenhouses at the top of the hill provide the resilient food process to the Community Hall kitchens, and host residences for Hall employees.

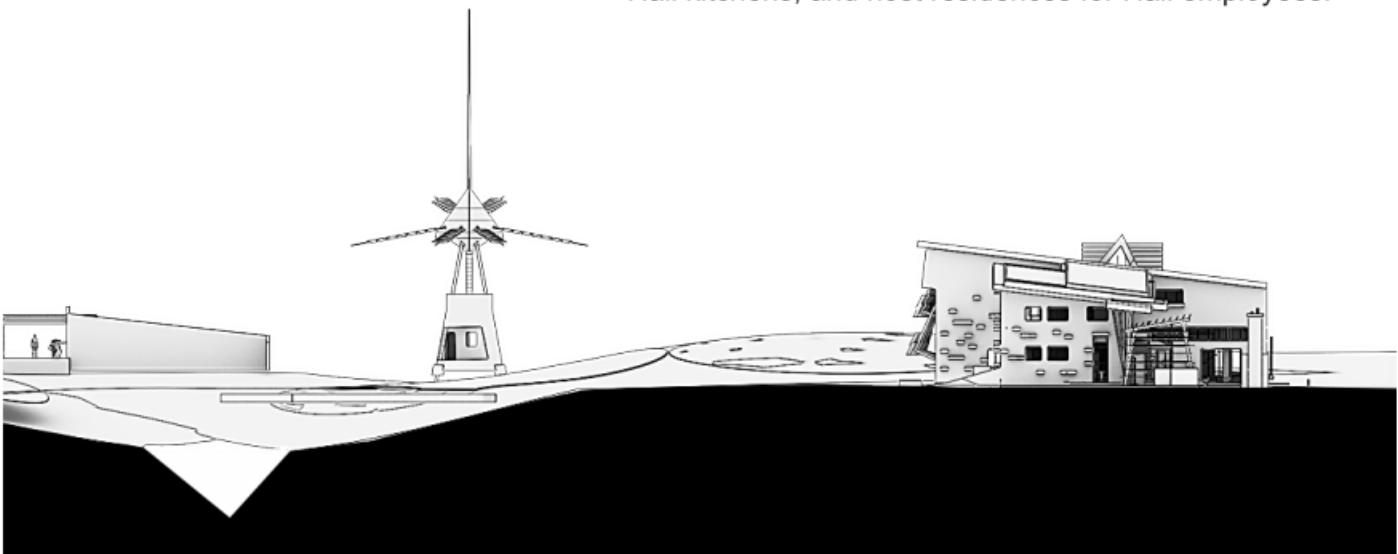

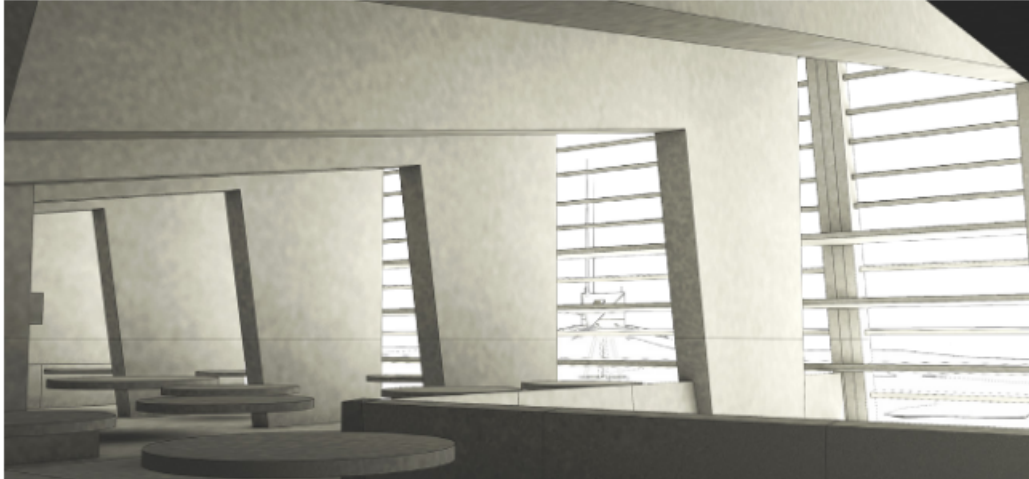

Interior Perspective_Community Hall_Mezzanine and the Living Wall

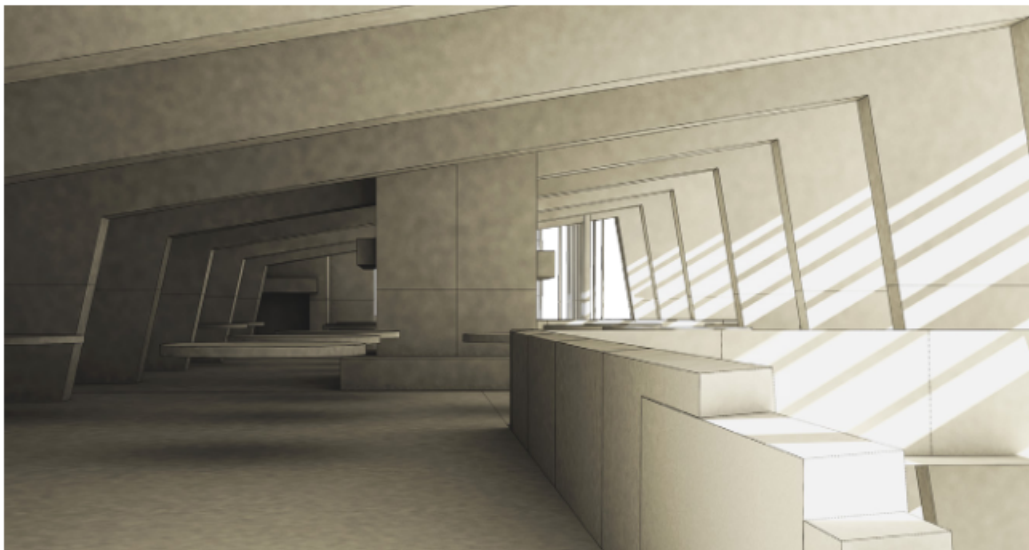

Interior Perspective_Community Hall_Mezzanine

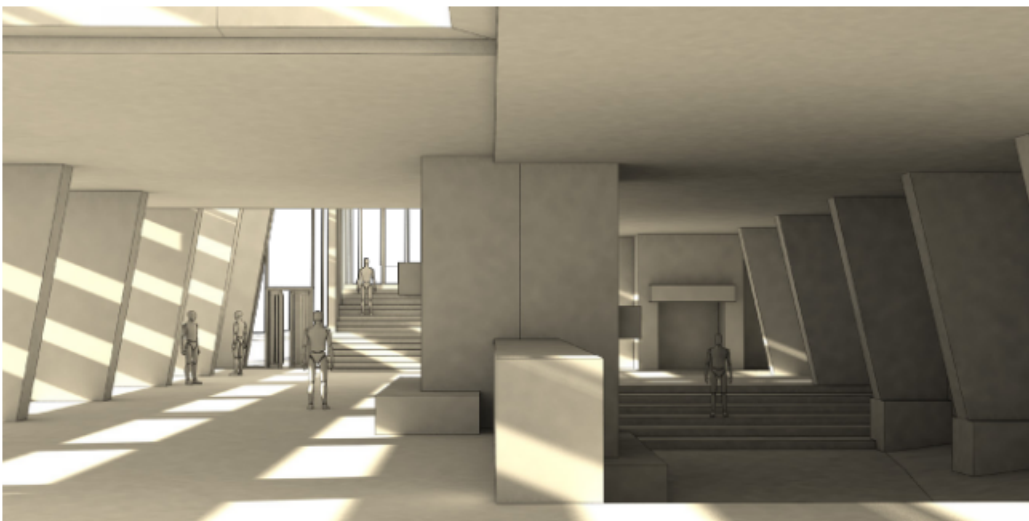

Interior Perspective_Community Hall_Main Floor Hall and the Dance Floor

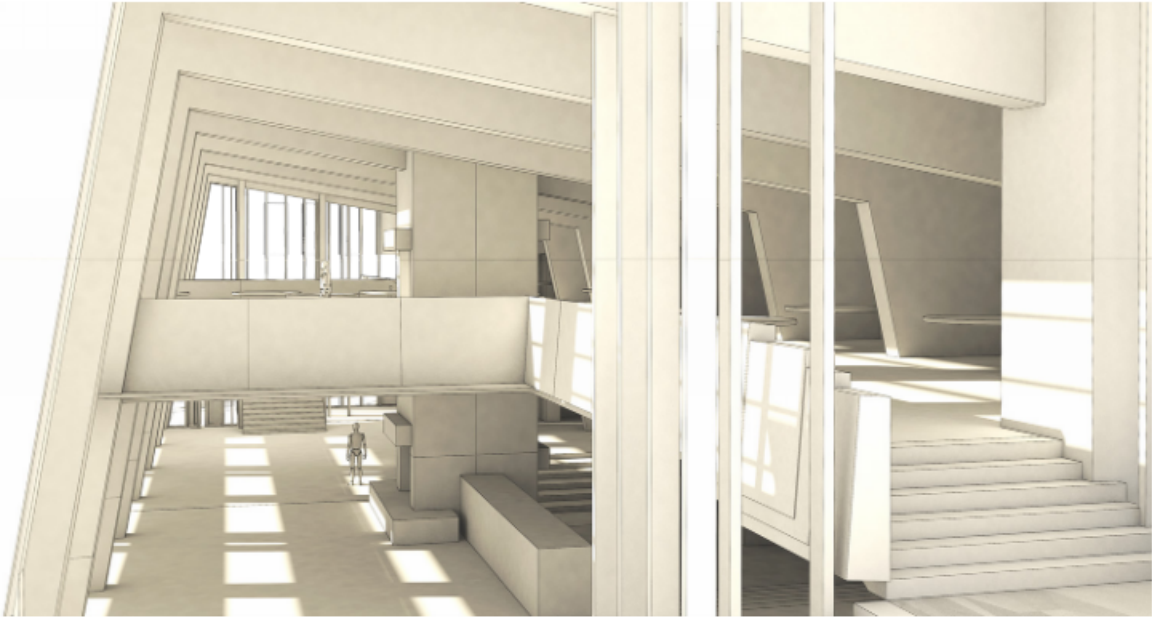

Interior Perspective of the Community Hall

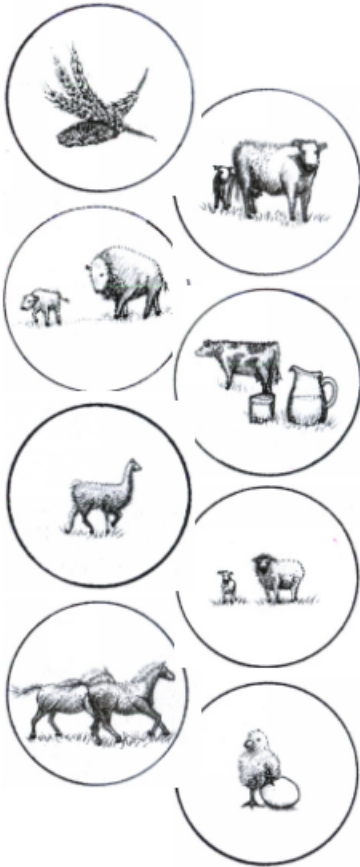

Rural products interface with urban consumers in the Community Hall.

Conclusion

A question was posed early in this thesis; how can the architect revitalize rural landscapes by reconnecting consumers to the agricultural process. The solution is not simple and does not exist as a single architectural iteration. Because industrial agriculture is non-sustainable, agriculture must regain some semblance of resiliency so that we may maintain our quality of life and afford our offspring the same opportunities. The architect must interpret the design language of existing communities to coherently develop strategies for revitalization. More so, the architecture must impress upon consumers and producers alike how to make a sustainable process resilient to time and socio-technical progression.

Ultimately, the architect must become a holistic designer, fulfilling roles of community planner and entrepreneur simultaneously to expose all opportunities for resilient rural landscapes. As the urban model demonstrates,



Exterior Perspective_Community Hall_Looking to Community Hall from Producer Barn

rural communities must embrace a cohesive Live/Work/Play lifestyle to entrench values of stewardship within the producer/consumer. If architectural programming can relay new associations between the productive rural landscape and the ideal lifestyle of the urban consumer, than space and time align to catalyze the individuals experience. This experience extends from the senses and manifests through the intersection of material, atmosphere, season, company, and activity - the engagement of sensory, cognitive, and subconscious faculties. Given the pursuit of environmental, economic, social, and cultural sustainability, agricultural communities and generational family farms represent a significant opportunity to educate urban consumers of the material wealth that exists at their doorsteps.

Generation after generation augments the rural landscape to accommodate the need and demand of urban centres. If architecture can demonstrate the ability of rural landscapes to produce basic commodities like food, energy, and building materials, then consumers will seek local producers for the experiential value of the rural landscape. When this experience is accentuated by the value-added product, then relationships between the sustainable agricultural process and the urban consumer are catalyzed. The challenge of the architect-planner-entrepreneur is thusly focusing on an agricultural product that can effectively influence a multiplicity of consumer products to ensure its uptake as a necessary socio-technical transition.

Given industrial Hemps close association to the progression of human civilization, it experienced a brief prohibition during a period of great technological

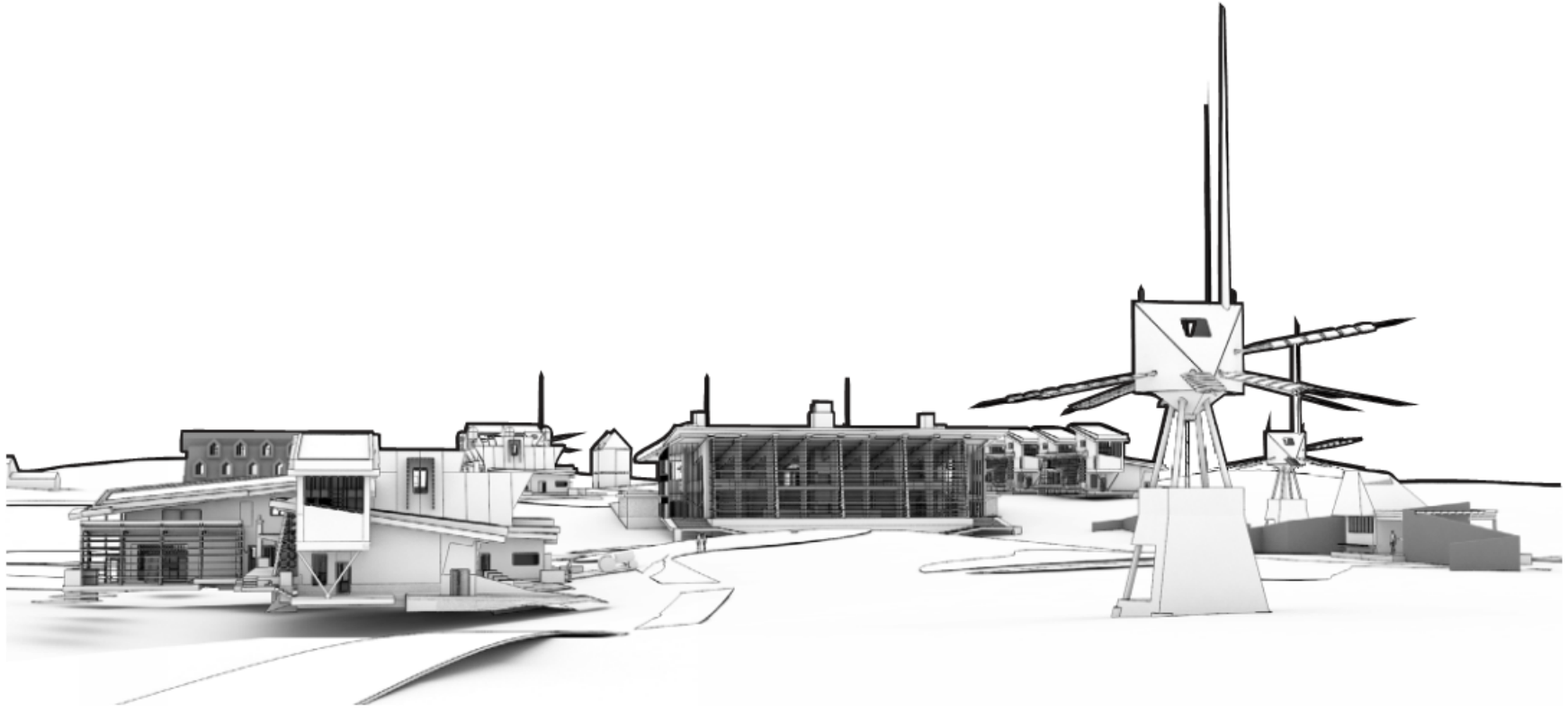

Exterior Perspective_Community Hall_Looking to Community Hall from Producer Farmhouse

advancement that has made its industrial production a rarity in North America. When utilized as a building material, the Hemp shiv and hydraulic lime cement create a formidable natural building material that fulfills the environmental, economic, social and cultural necessities of a sustainable building process. As well, decortication of the Hemp plant affords rural communities new production, commercial, and artisan craft opportunities through the plants distinct material decomposition of fibre, shiv, and dust. What communities require are industrial processing facilities that offer new economic potential to the rural landscape in return for adopting sustainable practices.

If the architecture can expressly convey the instinctual connection between the industrial Hemp plant and sustainable rural communities, then the question of a revitalized rural landscape is potentially answered via a consumable product - the building itself. The challenge is replicating the established industrial agricultural process in a sustainable manner, requiring not one, but many iterations of moments where food, energy, and product interface the producer/consumer. By adapting simple systems for qualitative agricultural production to return the greatest value for effort, secondary systems develop to fill market and production gaps given the demand for the product and accessibility to economical raw material.

Initially, the development of Hemp production will require costly decortication facilities that provide direct returns to the rural producer; whether through the purchasing of raw bio-fibre agricultural products, or through the immediate provision of natural and sustainable

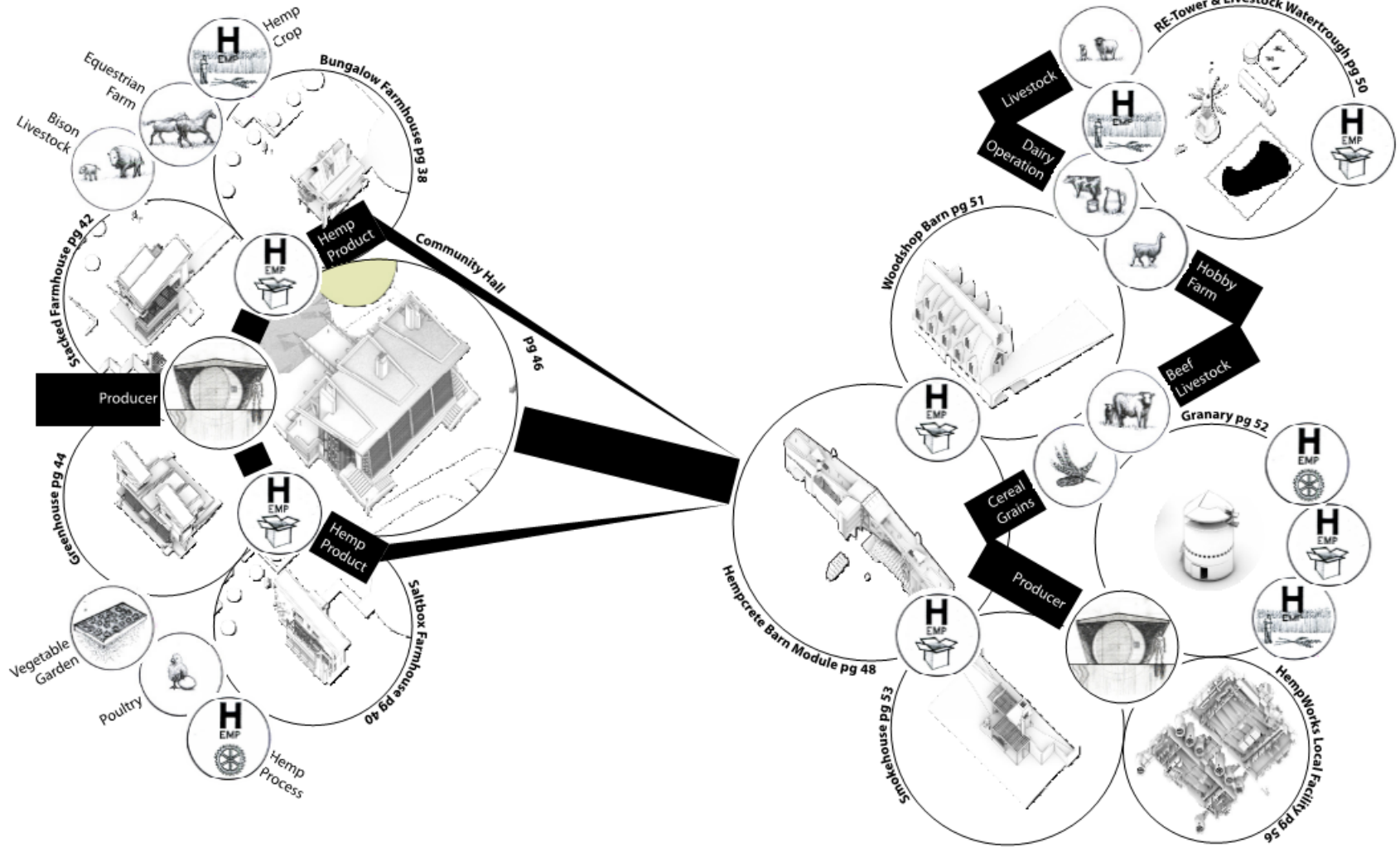

Catalyst.

Having experienced the sustainable rural community, consumers are now knowledgeable of processes, products, and producers that can assist their lifestyle. Built form becomes billboard of rural resiliency.

building materials or products. Consequently, agricultural buildings must be developed with generational producers to implicitly demonstrate to consumers how Hemp can provide an economical and aesthetically striking material culture at residential, commercial, and industrial scales simultaneously.

When fully realized, the Hemp Network will represent a community investment into sustainability, and may become a model for regional and national resiliency as HempWorks Local is imitated. Success of this model hinges on the ability of the rural producer to invest in the sustainable agricultural process and their ability to disseminate that process to their social and cultural associations. As generational farmers create new opportunities for their offspring, future consumers benefit as well - perpetuating the sustainable process and achieving resiliency. If Hempcrete buildings can easily transition from rural to urban, then our society can reacquisition a lost material culture that synthesizes natural processes into anthropogenic development.

Bibliography

- Alberta Agriculture and Forestry. "Industrial Hemp Production in Canada." Last modified June 20, 2016. [http://www1.agric.gov.ab.ca/\\$department/deptdocs.nsf/all/econ9631](http://www1.agric.gov.ab.ca/$department/deptdocs.nsf/all/econ9631)
- Alberta Agriculture and Forestry. "Industrial Hemp." Last modified June 20, 2016. <http://www.agr.gc.ca/eng/industry-markets-and-trade/statistics-and-market-information/by-product-sector/crops/pulses-and-special-crops-canadian-industry/industrial-Hemp>
- Archdaily. "Bruder Klaus Field Chapel / Peter Zumthor." Last modified January 26, 2011. <http://www.archdaily.com/106352/bruder-klaus-field-chapel-peter-zumthor>
- Archdaily. "Living on the Edge / Arjen Reas." Last modified October 20, 2010. <http://www.archdaily.com/82455/living-on-the-edge-arjen-reas>
- Austen, Ian. "Oilsands boom dries up in Alberta, taking thousands of jobs with it." *The New York Times*. October 13, 2015. <http://www.nytimes.com>
- Bane, Peter, and Holmgren, David, eds. *The Permaculture Handbook*. Gabriola, BC: New Society Publishers, 2012. Kindle edition.
- Boddy, Trevor. *Modern Architecture in Alberta*. Altona: D.W. Friesen & Sons Ltd., 1987.
- Bolles+Wilson. "R+S Yellow Distribution". Last modified June 20, 2016. <http://bolles-wilson.com/>
- Bouloc, Pierre., Allegret, Serge, Arnaud, Laurent, and C.A.B, eds. *International. Hemp Industrial Production and Uses*. Wallingford, Oxfordshire, UK ; Cambridge, MA: CABI, 2013. Kindle edition.
- Center for Applied Transect Studies. "SmartCode Version 9.2." Last modified March 24, 2015. <http://transect.org/codes.html>
- Coyle, Stephen. *Sustainable and Resilient Communities: A Comprehensive Action Plan for Towns, Cities, and Regions*. Hoboken, NJ: John Wiley & Sons, 2011.
- Cretes. "Fibre Processing." Last modified June 20, 2016. http://www.cretes.be/en/category_50.aspx
- Dequaire, X. "Passivhaus as a Low-Energy Building Standard: Contribution to a Typology". *Energy Efficiency*, 5 (2012): 377-391.
- Dixon, Tyler. "Exodus: The Disappearing Rural History of Alberta." MArch diss., Dalhousie University, 2006. Order No. MR20493.
- Eyck, Aldo Van, Ligtelijn, Vincent, and Strauven, Francis, eds. *Writings*. Amsterdam: SUN, 2008.

- Epp, Roger Ivan, Whitson, David, and Parkland Institute. *Writing off the Rural West : Globalization, Governments and the Transformation of Rural Communities*. Edmonton: University of Alberta Press, 2001.
- Farias, Ignacio, and Bender, Thomas, eds. *Urban Assemblages: How Actor-network Theory Changes Urban Studies*. Questioning Cities Series. London ; New York: Routledge, 2010.
- Fillion, Janelle. "Industrial Commemoration: A Grain Elevator Prototype for Economic Development in Rural Manitoba." MArch diss., Dalhousie University, 2015.
- Fluck, R., and Baird, C. Direlle. *Agricultural Energetics*. Westport, Conn.: AVI Pub. 1980.
- Globe and Mail. "Taking Customer Experience to the Next Level." *Globe and Mail: Report on Business*, December, 2015. Print edition.
- Hobsbawn-Smith, Dee. *Foodshed: an Edible Alberta Alphabet*. Victoria, B.C.: TouchWood Editions, 2011.
- James, Byron, (Plant Operations Manager), in discussion with the author, December 17, 2015.
- Jevremović Ljiljana, Turnšek Branko A.J., Vasić Milanka, & Jordanović Marina. "Passive design applications - industrial architecture perspective." *Facta Universitatis Series : Architecture and Civil Engineering*, 12 (2014):173-182.
- Just Bio Fibre Structural Solutions. "Home." Last modified August 16, 2016. <http://justbiofiber.ca/>
- Kroeker, Richard. "Building Systems." Dalhousie University, Lecture presented at Dalhousie University, Halifax, Nova Scotia, November 19, 2015.
- Lefavre, Liane., Roode, Ingeborg De, Fuchs, Rudi, and Amsterdam. *Aldo Van Eyck: The Playgrounds and the City*. Amsterdam: Rotterdam: Stedelijk Museum; NAI Publishers, 2002.
- LGA Architectural Partners. "973 Lansdowne Avenue." Last modified June 20, 2016. <http://lga-ap.com/project/residential/lansdowne>
- Matchbox Energy. "Matchbox Energy Calculator." Last modified June 20, 2016. <https://www.matchboxenergy.com/>
- Norberg-Schulz, Christian. *The Concept of Dwelling : On the Way to Figurative Architecture*. Architectural Documents. Milan : New York: Electa ; Rizzoli, 1985.

- Reguly, E. "Short of Breath." *Globe and Mail: Report on Business*, December, 2015. Print edition.
- Richard Kroeker Design. "Home." Last modified January 3, 2010. <http://www.richardkroekerdesign.com/projects.html#projects>
- Sears, Roebuck and Co. *Trade Catalogue: Modern Farm Buildings already cut and fitted: barn equipment*. Sears, Roebuck and Co., 1928. <https://archive.org/details/SearsRoebuckCoModernFarmBuildingsBarnEquip0001>
- Smaller, C., Wei, Q., & Yalan, L.. "The Quest for Commodities: Chinese Investment in Farmland." *International Institute for Sustainable Development*, June 26, 2013. <https://www.iisd.org/itn/2013/06/26/the-quest-for-commodities-chinese-investment-in-farmland/>
- Sondles, Scott. *Hemponomics: Unleashing the Power of Sustainable Growth*. E-book Corporation, 2013. Kindle edition.
- Stanwix, William, and Alex Sparrow. *The Hempcrete Book Designing and Building with Hemp-Lime*. Chicago: UIT Cambridge, 2014. Kindle edition.
- Tekle, Tam, (President & CEO, TTS Inc.), in discussion with the author, January 4, 2016.
- Wright, Julia. *Sustainable Agriculture and Food Security in an Era of Oil Scarcity : Lessons from Cuba*. London ; Sterling, VA: Earthscan, 2009.