

**EXTREME ADAPTIVE REUSE:
THE ANALYTICS OF DECONSTRUCTION AND
THE UPCYCLING OF BUILDING MATERIALS**

by

Emily A. Finkelstein

Submitted in partial fulfilment of the requirements
for the degree of Master of Architecture

at

Dalhousie University
Halifax, Nova Scotia
July 2014

© Copyright by Emily A. Finkelstein, 2014

DEDICATION

For my mom, Dr. Pauline Elaine Scales.

CONTENTS

| | |
|------------------------------------------------------------------------------|----|
| Abstract | v |
| Acknowledgements | vi |
| Chapter 1: Introduction | 1 |
| Thesis Question | 1 |
| Building Deconstruction | 2 |
| Precedents | 3 |
| Case Study #1: The Riverdale Project | 4 |
| Case Study #2: The Athletes' Village for the London 2012 Summer Olympics ... | 5 |
| Material Upcycling: One Man's Trash is Another Man's Treasure | 8 |
| Chapter 2: Site | 10 |
| History | 10 |
| The Barrington Street Heritage Conservation District | 11 |
| Building Site: The Vogue Optical Building | 14 |
| Common Responses | 20 |
| Facadism | 22 |
| Demolition | 23 |
| Chapter 3: The Deconstruction of the Vogue Optical Building | 25 |
| Building Description | 26 |
| The Deconstruction Method | 27 |
| The Sequence of Deconstruction | 32 |
| The Sequence of Tasks | 33 |
| Material Selection | 37 |
| Chapter 4: Design | 41 |
| Design Intentions | 41 |
| Design Concepts | 43 |
| The Unconventional Design Method | 46 |
| The Focal Point of the Design | 47 |
| Building Program | 50 |
| The New Building Design | 52 |
| Chapter 5: Conclusion | 62 |

| | |
|--------------------|----|
| Appendix | 64 |
| Bibliography | 70 |

ABSTRACT

This thesis focuses on the process of building deconstruction and the upcycling of building materials. It critiques the staggering amount of waste the construction industry (and by extension architectural profession) produces and the controversial practice of façadism. These areas are studied by focusing on the Vogue Optical Building located on Barrington Street in downtown Halifax, Nova Scotia, Canada. This thesis intends to become a case study reference for future deconstruction projects, present an alternative option to demolition and façadism and most importantly, to demonstrate how the life cycle of a material can be extended through creative upcycling and transformation.

ACKNOWLEDGEMENTS

I would like to thank Roger Mullin, Steve Parcell and Maria Elisa Navarro Morales for your guidance, advice and insight throughout the thesis process.

Thank you Dan, for always making me smile.

CHAPTER 1: INTRODUCTION

Thesis Question

What are the limits to building deconstruction? Can its application as a method of demolition be promoted through the creative implementation of material upcycling and recycling?

Buildings account for one sixth of the world's fresh water withdrawals, a quarter of its wood harvest and two fifths of its material and energy flows.¹ This causes deforestation, air and water pollution, stratospheric ozone depletion and raises the risk of global warming. People tend to focus on automobiles or factories when they speak about reducing pollution, but in actuality buildings and the construction industry do greater harm to the environment and are a much more manageable problem to tackle.

Construction and demolition (C&D) debris consists of waste that is generated during new construction, renovation, and demolition of buildings, roads and bridges. It often contains bulky items such as concrete and brick and significant amounts of this waste end up in landfills or incinerators every year. According to the 2009 report, *Construction and Demolition Waste Management in the Northeast in 2006*, published by the Northeast Waste Management Officials Association, the total C&D waste generated in the Northeast (the six New England States, New York and New Jersey) in 2006 was approximately 12,065,582 tons. That is around 0.19 to 0.42 tons per person per year.²

In Canada, the construction industry has produced large amounts of waste for decades, while the total volume produced continues to rise in many regions.³ While construction and demolition wastes are usually grouped together under the common title "C&D waste," the amount of waste they produce can vary greatly. Demolition projects often

1 David Malin Roodman and Nicholas Lenssen, *A Building Revolution: How Ecology and Health Concerns Are Transforming Construction*, ed. Jane A. Peterson. (Washington, DC: Worldwatch Institute 1995), 20.

2 United States Environmental Protection Agency, "Construction and Demolition (C&D) Debris," April 22, 2014, <<http://www.epa.gov/region1/solidwaste/cnd/>>.

3 Colin Jeffrey, "Construction and Demolition Waste Recycling," Dalhousie University's Office of Sustainability, *Resource and Recovery Fund Board of Nova Scotia*, (2011), 3, <<http://tinyurl.com/q7tf4an>>.

produce 20-30 times as much waste material per square meter as construction projects.⁴ In addition, demolition waste is often contaminated with paint, adhesives and dirt and the materials can be securely fastened together, making separation more difficult.

For these reasons, building deconstruction needs to be researched more, as there is an incredible amount of potential being wasted in landfills.

Building Deconstruction

The term deconstruction can also be called “construction in reverse,” and is a new way of describing an old process, that of the selective dismantlement of building components, specifically for re-use, recycle and waste management.

It is not a commonly practiced form of tearing down a building, yet at the rate that the world is using up resources and raw materials, it will soon have to be. World-watch Institute estimates that by the year 2030 the world will have run out of many raw building materials and we will be reliant on recycling and mining landfills.⁵ The demolition of buildings and infrastructure produces significantly more C&D waste than either renovation or construction. It has been estimated that renovation and demolition projects together produce approximately 90% of a nation’s C&D waste, or 9.8kg for each m² that is demolished.⁶ Traditionally, low tipping fees at landfills and affordable raw materials have suppressed interest in reusing or recycling building materials produced through demolition. Therefore until recently, demolition contractors have focused on demolishing a structure as quickly and efficiently as possible with little regard for optimizing waste recycling opportunities.

Deconstruction is starting to be employed more and more as resources are becoming increasingly scarce (therefore more expensive) and as municipalities enact laws regulating the disposal of construction materials. In Nova Scotia, the Halifax Regional Municipality has recently passed a by-law banning several construction materials from its

4 Jeffrey, “Construction and Demolition Waste Recycling,” 3.

5 Mark Gorgolewski, “Reusing Buildings and Components,” *Ontario Architects Association* (2009), 1, <www.oaa.on.ca>.

6 Jeffrey, “Construction and Demolition Waste Recycling,” 10.

landfills and requiring a 75% diversion rate for C&D waste.⁷

This thesis will explore the method of deconstruction and take it even further by attempting to reuse those materials from a deconstructed building in the design of a new building on the same site.

Precedents

“The intelligent handling of waste has become a pressing issue today, but in other ages and civilizations it was an integral part of society. In architecture, for example, it was common practice to reuse stones from great monumental constructions in Egypt, Greece, and Rome that had been knocked down by earthquakes or wars, or simply abandoned, as this involved much less effort than extracting new stone and transporting it from distant quarries. Very little trace remains of the tons of iron used by the Romans in their buildings, as it was almost entirely reused in both the construction industry and the manufacturing of machines and weapons. Most medieval cathedrals are set on the site of an old church, which provided foundations and many of its stones for the new structure. Up until the 19th century, recycling elements from old buildings was practically the norm all over the world. Today it still takes place in developing countries, not as an environmental initiative but as a measure for relieving extreme poverty.”⁸

In the Western world, we currently live in a society where the more money or resources a person or company has, the less likely they are to reuse materials and the more likely they are to waste resources. However, as the cost of building materials continues to rise, the demand for used building materials will increase and individuals will be ever more encouraged to maintain their properties. In the future it is not so far-fetched of an idea to envision that when discussing a building's worth, in addition to its market and property values, we will also take into consideration the resale and reuse value of its salvageable building materials. “There may be a time when the assessed value of an existing structure is less than the cumulative sale price of its dismantled materials and

7 Jeffrey, “Construction and Demolition Waste Recycling,” 5.

8 Alejandro Bahamón and Maria Camila Sanjinés. *Rematerial: From Waste to Architecture*, (New York: W.W. Norton, 2010), Introduction.

equipment. Older buildings become cash cows for deconstruction and resale.”⁹

Although building deconstruction is not a commonly practiced method, it continues to be researched and case studies conducted more and more.

Case Study #1: The Riverdale Project

The Riverdale Case Study was sponsored and prepared for the United States Environmental Protection Agency by the NAHB (National Association of Home Builders) Research Center Inc. Throughout every stage of deconstruction, the process was recorded and analyzed in detail and proved to be an invaluable resource for this thesis.¹⁰

Location

Baltimore, Maryland, USA

Description

The manual disassembly and salvage of a 2,000 square foot building made up of four residential units. The building is part of a 600-unit housing development, and if this pilot project proves to be successful, it will be used as a framework and guideline in the deconstruction of the additional 300,000 square feet of building in the development.

Project Objectives

- To conduct a comprehensive study that investigates and compares the issues involved with the deconstruction of a building as an alternative to conventional demolition.
- To identify major issues hindering deconstruction as an alternative to conventional demolition.
- To determine unit labour requirements for deconstruction activities, to evaluate jobsite practices such as sequencing and layout of operations.
- To determine market opportunities and values of salvaged building materials.

9 David E. Brown, Mindy Fox and Mary Rickel Pelletier, eds., *Sustainable Architecture White Papers*, (New York, NY: Earth Pledge Foundation, 2000), 26.

10 NAHB Research Center Inc., “Deconstruction - Building Disassembly and Material Salvage: The Riverdale Case Study,” (Upper Marlboro, Maryland: *US Environmental Protection Agency: The Urban and Economic Development Division*, 1997).

- To disseminate information on building disassembly and salvage.

Method

A detailed building inventory of the structure was taken, where every component, its condition, and the manner in which it was secured to the structure was recorded. Then the building was deconstructed in the reverse order of construction (i.e. those components installed last were removed first). The Research Center recorded each worker's labour in 15-minute intervals, which provided over 4,000 data points for the entire deconstruction project. Each observation was categorized into one of four tasks:

- Disassembly: physical detachment from building (prying, lifting, pulling, etc.)
- Processing: moving disassembled materials to storage location (cleaning, separating, denailing, stocking and bundling)
- Production Support: required steps for disassembly or processing (talking business, supervision, erecting scaffolding, etc.)
- Non-production: down-time associated with job site activities and research (idle, breaks, research monitoring, etc.)

Every aspect of the process was recorded, from labour costs and availability, disposal costs, market demand for used building materials, and total labour-hours for each building component and task. (See Table 1 in Appendix for detailed breakdown of the data).

Results

The project provided an incredibly detailed report and analysis of the process of deconstruction and although it cost more and took more time, this was the pilot project and the team learned throughout the process. This report will provide valuable information and be an incredibly useful resource for deconstruction projects in the future.

Case Study #2: The Athletes' Village for the London 2012 Summer Olympics

In order for deconstruction to be a more viable option to demolition, buildings must be designed with flexibility of use in mind. This includes material selection (and how various materials are fastened to one another), structural design and flexibility of

spaces. The needs of communities are constantly changing as they evolve. For example, a school could be required one year, and as the population ages, a senior's residence needed a couple decades later. An example of this can be seen every two years with the Olympics. Large housing complexes must be constructed for the mass of athletes who descend onto the city for a two-week period. The Olympics are a one-time event and provide an excellent opportunity for further research and exploration into the practice of deconstruction.¹¹



Aerial photo of the London 2012 Olympic Athletes' Village, 2013; photograph by EG Focus, from "Live in an Olympic Superstar's Apartment: London's East Village Opens," *Buildington Blog*.

Location

Olympic Park, Stratford, London, United Kingdom.

Project Description

Accommodation for 17,000 athletes was required for the 2012 Summer Olympics. As part of the regeneration program to win the bid for the Games, the design of the Olympic Village was based on reusing the buildings after the Games for a new residential district. Beginning in October 2012, the Athletes' Village accommodations were retrofitted into 2,818 new homes.

¹¹ "Designing for Deconstruction and Flexibility Case Study: Olympic and Paralympic Games Village, Stratford," (Banbury, England: WRAP, 2012), <www.wrap.org.uk/construction>.

Project Design

The residences were initially designed with deconstruction and flexibility of uses in mind. A range of approaches were implemented to achieve this including:

- Cladding panels that are interchangeable
- Built elements such as partitions can be moved to reconfigure space if needed
- All temporary gypsum partitions are fully recyclable

Materials were selected based on the following criteria:

- Material life
- Maintenance costs and life expectancy
- Sustainability credentials

In addition to creating buildings with flexibility and deconstruction in mind, when designing them the architects strived to keep design variations to a minimum. Also, every material and component was selected for its quality and potential for reuse. This resulted in every accommodation being guaranteed to be structurally sound for 60 years.

Results

The project was committed to using sustainable and recycled materials throughout the project, which resulted in:

- A diversion rate of 95.6% of construction waste from landfills
- All carpets had minimum 50% recycled content
- 85% of bulk items for concrete were delivered by rail, saving 40,000 tonnes of embodied carbon compared to delivering by truck
- Rainwater harvesting systems were installed
- End of life potential: When (and if) the building is eventually demolished the concrete frame can be crushed again for reuse.
- The main building that was used for organizing and managing teams during the Games has been turned into an elementary school, high school and community centre for the new community.

Material Upcycling: One Man's Trash is Another Man's Treasure

To upcycle is to reuse (discarded objects or material) in such a way as to create a product of higher quality or value than the original.

MATERIAL UPCYCLING

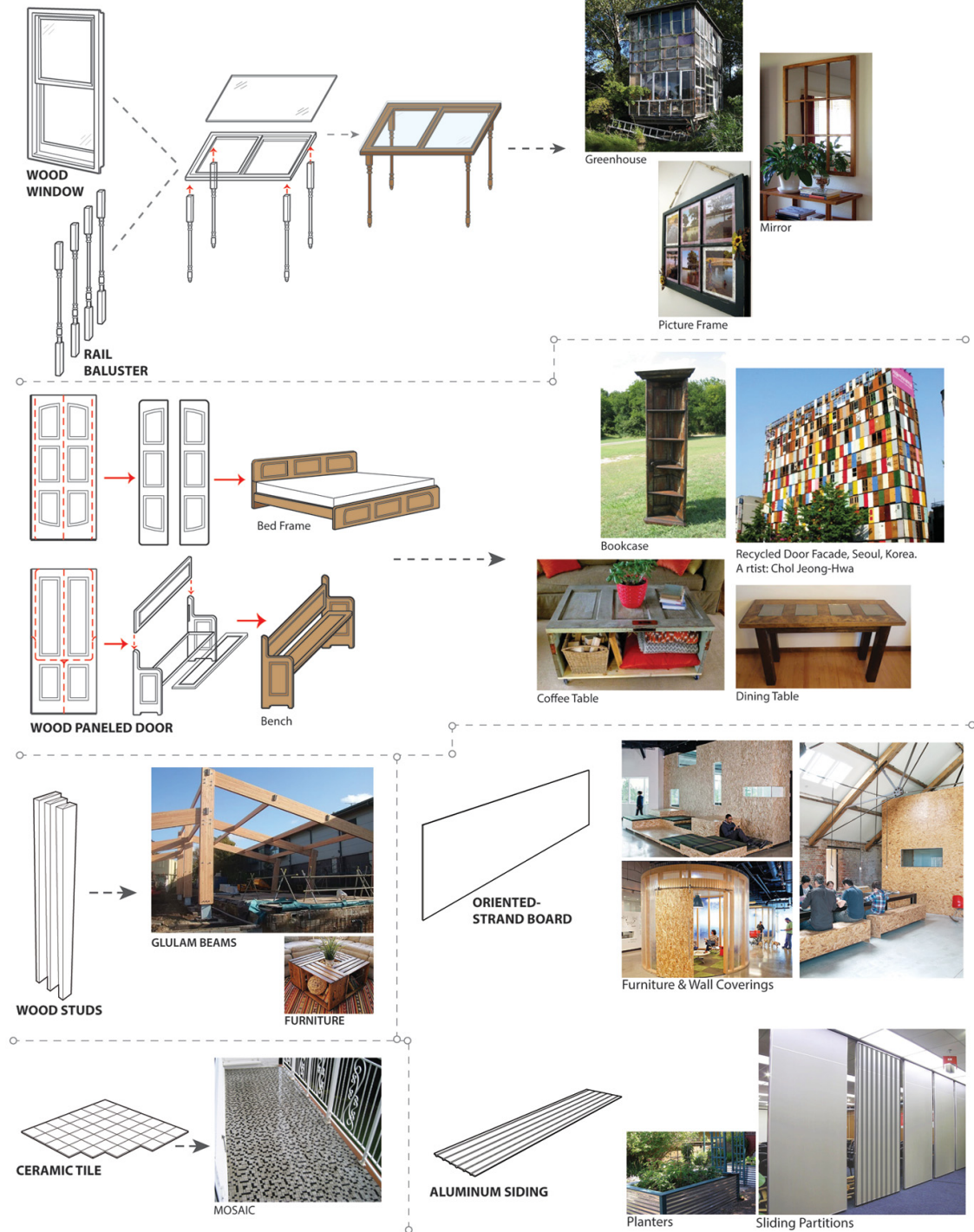

Upcycling examples of a selection of materials from the Vogue Optical Building

The goal of upcycling is to prevent wasting potentially useful materials by making use of existing ones. Similar to recycling, this reduces the consumption of raw materials and the embodied energy of creating new products. Although the upcycling of construction materials is not common practice (yet), the upcycling of building finishes and fixtures is becoming more popular. For instance, prior to the demolition of many buildings the “valuable” materials are removed and sold to the public. This list can include everything from antique doors and windows to wood flooring and metal radiators. These materials can then be reused as is, or transformed into something new. For example, an old door can be combined with rail balusters to create an unique table. The possibilities are endless with material upcycling and its success is only limited by a person’s creativity. This thesis will involve the more common form of upcycling of re-purposing fixtures and finishes as well as the upcycling of construction materials.

CHAPTER 2: SITE

“Don’t fix it if it isn’t broken,” is a common mantra that many people subscribe to and one of the reasons why I looked to Barrington Street for the selection of my thesis building site. It is hard for one to argue that there is not ‘something broken’ with Barrington Street in downtown Halifax. Throughout the past decade (and for many decades prior), business after business have shut their doors with nothing opening to replace them. Within the four city blocks of Barrington Street that run through the downtown core (between Blowers Street and Duke Street), there are currently 10 vacant storefronts at street level, in addition to the numerous vacancies among the building’s upper floors.

In addition to the vacancies, many of the buildings have been neglected over the years and are in dire need of repair. There are various reasons as to why there are so many vacancies and crumbling buildings in the area, and we have reached the point that they have been neglected for so long that simply patching the building and giving it a fresh coat of paint is not good enough. Major change must come to Barrington Street in order to improve the public’s perception of it, and breathe new life into the downtown core. Two of the more commonly applied solutions to improve the downtown landscape are complete building demolition, and new construction with façadism, both of which come with controversy. With this thesis I propose an alternative: deconstruction, material upcycling and adaptive reuse.

History

Barrington Street was one of the first streets to be laid out when the town of Halifax was founded in 1749 and has been the city’s centre of commerce for the past 250 years.¹² The street blossomed in the late 19th century and flourished throughout the first half of the 20th century until it entered a state of decline during the late 20th century through to present day. The street has a dynamic profile with a unique heritage character comprised of Victorian, Edwardian and Early Modern commercial buildings that distinguish it from adjacent streets. Yet, it is also characterized by crumbling building facades and neglected storefronts.

¹² “Barrington Street Heritage Conservation District Revitalization Plan,” (Halifax: Halifax Regional Municipality, 2009), 1. <<http://tinyurl.com/ltzt8jm>>.

This negligence and decay can be attributed to a number of reasons, including: the financial costs of maintaining century-old buildings, the sometimes limiting guidelines and amount of permits required by the City to carry out construction on a heritage property and changes in building ownership. However, all of these vacancies and dilapidated buildings also create an incredible potential for the street, and, over the past few years, a number of developments have been undertaken to revitalize this valuable real estate.

The Barrington Street Heritage Conservation District

The downtown portion of Barrington Street is encompassed by the Barrington Street Heritage Conservation District, which runs from Duke Street south to Bishop Street and encompasses 47 properties. It is characterized by various historic architectural styles including: Georgian, Italianate, Art Deco and Chicago Style¹³ and has been the subject of much debate among the city's councillors, planners, developers and residents for many years. The Conservation District helps protect an important part of the city's history and should not be seen as a hindrance or an obstacle for new development. It is a needed piece of legislation that helps protect the vibrant profile of the street.

The overall objectives of the Barrington Street Heritage District Revitalization Plan are:

- To revitalize Barrington Street as a focus of retail, commercial, and cultural activity.
- To encourage restoration of heritage buildings and storefronts.
- To attract upmarket specialty retail, cultural, and entertainment uses at street level.
- To fill vacant space on upper floors and encourage conversion to residential use.
- To improve pedestrian environment in the public realm.
- To improve HRM's image and marketing potential.
- To restore investor confidence and trigger private investment.¹⁴

¹³ "Barrington Street Heritage Conservation Plan," 9.

¹⁴ "Barrington Street Heritage Conservation Plan," 1.

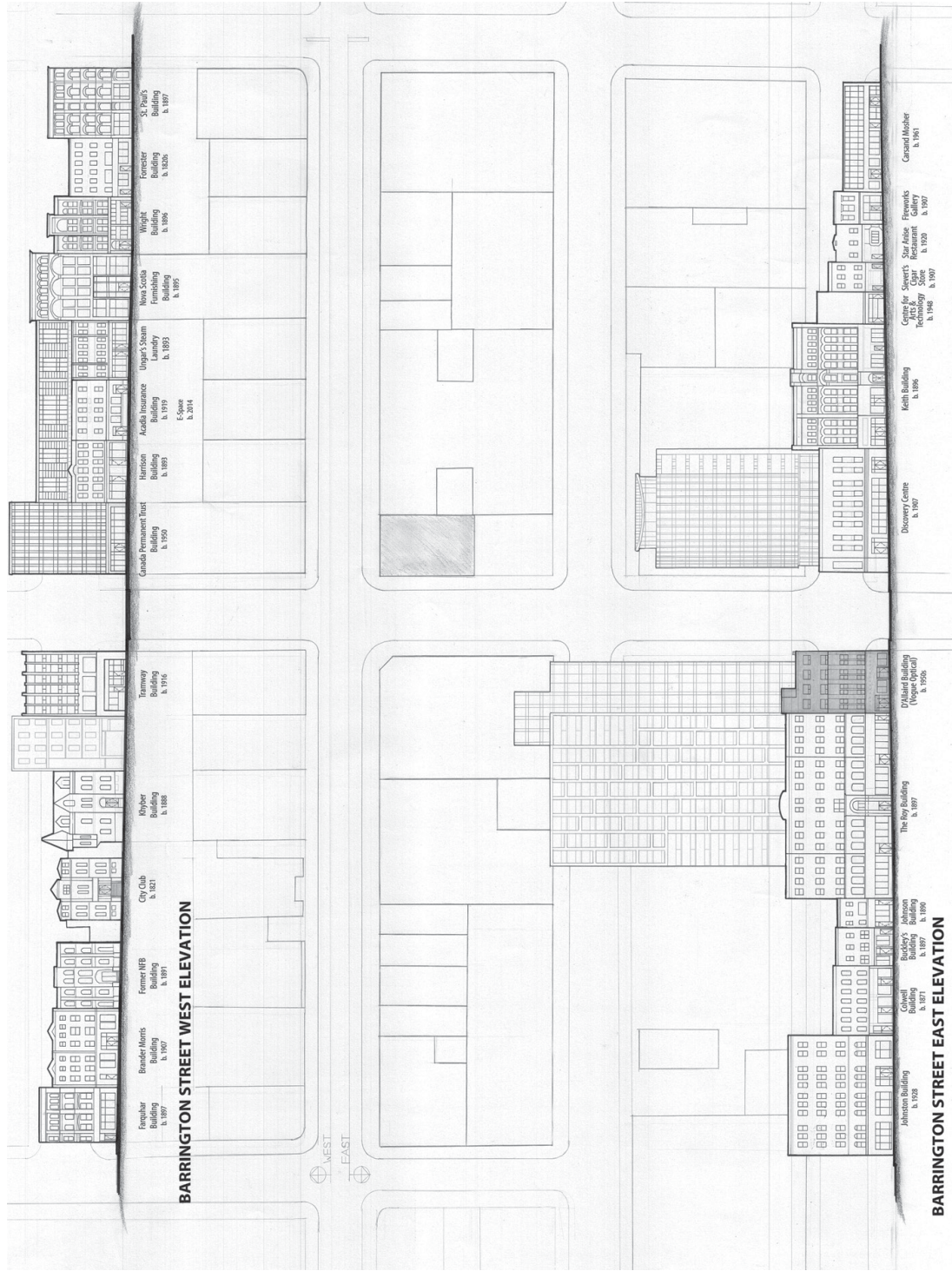

Barrington Street Elevations: Existing buildings drawn in ink, proposed developments in pencil and the Vogue Optical Building shaded in grey



Map of the Barrington Street Heritage Conservation District with the Vogue Optical Building highlighted in red, 2009; from "Barrington Street Heritage Conservation District Revitalization Plan," *Halifax Regional Municipality*

Building Site: The Vogue Optical Building



The Vogue Optical Building

The Vogue Optical Building is a commercial building located at 1645-49 Barrington Street at the northeast corner of the Sackville Street intersection. It is a five storey building (plus walk-in basement) that consists of a three-storey lower section of sandstone and two storey upper section of concrete block. The lower section was built in the 1950s and was a women's department store named D'Allaird's for many decades. The two upper floors were added in later years. Three of the building's five floors are currently vacant (including the basement) and the building's façade has been neglected for a number of years. This has resulted in rust stains on the stone façade, cracked panels and remnants of old store signage still visible on the building's elevation. Although the building is located within the Barrington St. Heritage Conservation District, it does not possess a heritage classified façade like many of its neighbours.

The Vogue Optical Building was selected for the site of my thesis for the following reasons:

1. Central downtown location: Barrington Street has been the centre of commerce in Halifax for the past 250 years.

2. Transit Corridor: That section of Barrington Street is one of the busiest transit corridors in the Halifax Regional Municipality (HRM), with 21 bus routes running in front of the Vogue Optical building and 500m away from the Halifax Ferry Terminal.



Bus and ferry transit routes in downtown Halifax, with the Vogue Optical Building highlighted in red; data from HRM GIS Database, 2012

3. Education: The building is located within walking distance of Dalhousie University Stud-ley Campus (main campus), Sexton Campus (Architecture and Engineering), the Nova Scotia College of Art and Design (NSCAD), St. Mary's University and a ferry ride away from the main campus of the Nova Scotia Community College (NSCC).



Post-secondary educational institutions in close proximity to site, with the Vogue Optical Building highlighted in red; data from HRM GIS Database, 2012

4. Protected View Planes: The city of Halifax has nine different protected view planes emanating from the Citadel which limit the height of buildings in order to protect harbour views. The Vogue Optical Building does not fall within any of these view planes and therefore its building height is not restricted.



The protected view planes from Citadel Hill, with the Vogue Optical Building highlighted in red; data from HRM Archives, 1971

5. Barrington Street Heritage Conservation District: The Vogue Optical Building is located within the boundaries of the Heritage District. This was a criterion when selecting a site in order to further demonstrate the alternatives to façadism and complete demolition of structures when dealing with heritage properties.

6. Current and Planned Developments: There are currently a large number of construction projects underway and planned within downtown Halifax. Of particular interest, the property directly across from the Vogue Optical Building is currently finishing construction, demolition has recently begun on the property adjacent (the Roy Building), and the property opposite on Sackville Street (the Discovery Centre), will begin construction within the next year or two. All three of these developments are implementing façadism in order to fulfil the requirements of the Heritage District Guidelines. As one of the critiques of this thesis is façadism, the building could not be better sited in order to show a direct comparison.

7. Building Materials: The Vogue Optical Building has a regular, rectangular footprint, reminiscent of the Maison Domino by Le Corbusier and is composed of a common set of construction materials. From the basement to the fourth level these include: concrete foundations, primary steel structure, corrugated steel decking floors and cast-in-place concrete. The two upper floors are constructed with structural wood members and sheathing, brick and concrete block. The exterior is clad with sandstone, marble, aluminum siding, brick, concrete block and wood and aluminum windows. This list of materials is fairly standard and can be found in a majority of commercial buildings in Halifax. In order for the method of deconstruction to be employed with more frequency, the case studies researching/employing it should contain building materials that exist in the widest range of buildings. In order for this thesis to prove to be a successful case study of the extreme adaptive reuse of materials the building must contain the most standard layout and construction as possible.



Current and planned developments in downtown Halifax, with the Vogue Optical Building in red; data from HRM GIS Database, 2012.

In summary the Vogue Optical Building was selected because it is situated in the heart of the city, located in a highly visible and trafficked area and in the middle of numerous construction projects and planned developments. None of which are employing the deconstruction method. The average person does not think about where their garbage or recycling goes once they put it out on the curb because the processing facilities and depots are located in remote locations outside the city (out of sight, out of mind). In comparison, many people do not know what happens to used building materials once a building has been demolished. By deconstructing a building and constructing a new design on the same site using recycled materials from its predecessor, people will be witness to an unconventional process. The buzz words “sustainable” and “green-design” are thrown around all too often without people actually knowing what they entail. These are broad terms that are too often used for publicity to help sell projects and ideas to people. When people are shown first-hand how the construction materials of a building can be recycled within their own communities they will hopefully be able to better grasp these ideas and come up with some of their own.

Common Responses

The city of Halifax is currently undergoing a dramatic change; the skyline is populated by numerous cranes and by the end of the decade the downtown profile will be completely transformed. There are a significant number of properties that have heritage classification within the city as well as the Barrington Street Heritage Conservation District, which encompasses a large section of the downtown. In order to meet the requirements of heritage conservation status one of the more commonly employed solutions has been façadism. All other construction projects downtown have undergone (or are currently undergoing) demolition, with the existing structure being completely demolished and a building consisting of all new materials constructed in its place.



Site plan showing the cases of Facadism and Demolition + New Construction in downtown Halifax, (Vogue Optical Building in red); data from HRM GIS Database, 2012

Facadism



Example of Facadism in downtown Halifax. Building located at the corner of Upper Water and Duke Streets.

The practice of Facadism is when an old building is completely demolished except for one or more of its facades, which is propped up using steel. Often a new, more modern looking building is constructed in its place, behind the historic facade. This helps maintain the character of the street, yet is surrounded by much controversy. For example, it has been claimed that facadism prevents new architectural styles from evolving and reduces buildings to ‘mere elevations or self-parodies.’¹⁵ It has been condemned for causing the divorce between the interior and exterior of buildings and creating townscapes which are little more than stage sets. It is also condemned by architectural purists as being immoral or distasteful.

The practice of façadism conflicts with the ICOMOS (International Council on Monuments and Sites) international charters. In the Venice Charter it states: “A monument is inseparable from the history to which it bears witness and from the setting in

¹⁵ Jonathan Richards, *Facadism*, (London: Routledge, 1994), Introduction.

which it occurs. The moving of all or part of a monument cannot be allowed except where the safeguarding of that monument demands it or where it is justified by national or international interest of paramount importance.”¹⁶

In Canada, FHBRO (Federal Heritage Buildings Review Office) recognizes that façadism has become a popular compromise between demolition and new development, but recognizes that it is an approach which undermines the integrity of the original building, its heritage character and the integrity of the contemporary design. Although they do not directly condemn it, FHBRO views the practice of façadism as a less than acceptable form of conservation. The FHBRO Code of Practice states: “Where the heritage character of a building lies both in its façade and its structure, interior finishes and spatial organization, façadism (or retention of only the façade of a building) is not an acceptable form of conservation. Where the heritage character rests strongly in the façade, and interiors have little value or have been much altered, retention of a façade in whole or in part may be acceptable but only as a solution of last resort.”¹⁷

This approach to heritage conservation has become very popular in the city of Halifax over the past few years, as it is arguably a loophole that developers have found which allows their developments to remain within the heritage district/building guidelines. Instead of employing creative ideas in order to ameliorate and work with an existing heritage building, too many have gone this route.

Demolition

Demolition is the action or process of demolishing (to pull or knock down a building).¹⁸ The two main techniques that are employed in demolition are manual demolition and building implosion. Manual demolition is the most commonly employed technique and it is when a structure is torn down from top to bottom using various types of heavy machinery, (hydraulic excavators, loaders, bulldozers, wrecking balls, etc.). Similar to build-

16 “International Charter for the Conservation and Restoration of Monuments and Sites (The Venice Charter 1964),” (*International Council of Monuments and Sites*, 1965), Article 7, <http://www.international.icomos.org/charters/venice_e.pdf>.

17 Parks Canada: Federal Heritage Buildings Review Office, *FHBRO Code of Practice*, ed. Herb Stovel, (Ottawa: Parks Canada, Federal Heritage Building Review Office, 1996), 33.

18 “Demolition,” Def. 1, *Oxford Dictionaries*, (Oxford: Oxford University Press, 2014), <www.oxforddictionaries.com>.

ing deconstruction, a general inventory of a building's materials is made and anything of value is noted and removed prior to commencing demolition. Very little training is required for demolition and most construction workers are familiar with the manual technique.¹⁹



The manual demolition of the Chronicle Herald building in downtown Halifax, 2010; from "The Chronicle-Herald Building Is Being Destroyed," *The Coast*.

Building implosion is the strategic placing of explosive material and timing of its detonation so that a structure collapses in on itself. It is typically used on high-rise buildings in urban areas and can reduce the demolition period by up to 80%, with the majority of time being spent in both the preparation period and clean-up following implosion. Although it is the fastest form of destruction, there are many risks associated with implosion, these include: adjacent property damage, shock vibration effect to neighbouring buildings and structural stability, and the danger of an explosive malfunctioning. There are also very high negative environmental impacts as almost none of the building's materials are salvageable and the potential to create significant amounts of airborne dust and particles.²⁰

19 New Zealand Demolition and Asbestos Association (NZDAA), "Demolition - Best Practice Guidelines for Demolition in New Zealand," *WorkSafe New Zealand*, (Wellington: WorkSafe New Zealand Board, 2011), Section 6, <<http://tinyurl.com/l66peq8>>.

20 New Zealand Demolition and Asbestos Association, Section 6.6.

CHAPTER 3: THE DECONSTRUCTION OF THE VOGUE OPTICAL BUILDING

The Vogue Optical Building



Barrington St. Elevation

Sackville St. Elevation

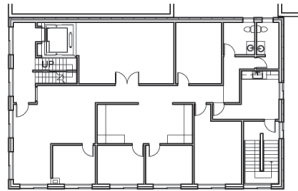

Level 5

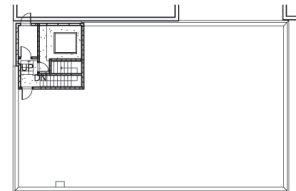

Roof

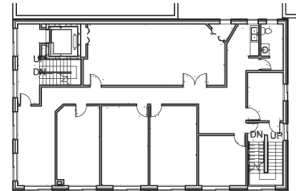

Level 4

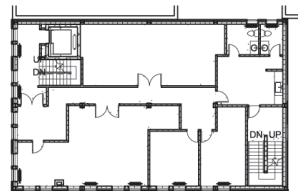

Level 3

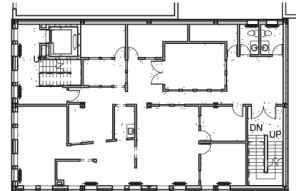

Level 2

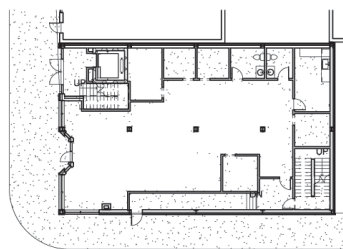

Main Floor

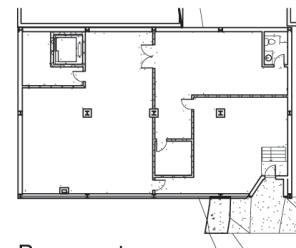

Basement

The Vogue Optical Building plans and elevations

Building Description

Size/Shape: 15,000 square foot, five-storey building (plus exposed basement along Sackville St. Elevation). Rectangular footprint (65'-0" x 40'-0"), flat roof.

Structural Components:

Concrete foundation walls up to Main Level, steel structural columns along the perimeter and one row of columns through the middle of the building that reach to the Fourth Level (15 columns total). Wood frame construction on the two upper floors.

Floors: Metal decking with poured concrete up to Fourth Level. Wood framed joists for upper floors (2x8s @ 16" o.c. with sheathing boards)

Interior Walls: Wood frame (2x4s)

Exterior Walls: 1'-0" wide, composed of brick masonry (4" brick), sandstone and marble facing on first three floors and concrete above. Aluminum siding on the east façade of the building

Finishes:

Floors: Ceramic tile, vinyl tile, vinyl sheets, carpet, wood strip flooring

Walls: painted drywall

Roofing: Typical commercial flat roof construction (sheathing, felt paper, gravel). Accessible by stairwell

Windows: Wood single hung (Second and Third Levels), aluminum framed (Fourth and Fifth Levels), all single glazed. Storefront glazing on Main level and basement.

Heating System: Electric baseboard heaters and hot water cast iron radiators. Copper domestic water piping.

Miscellaneous: As three of the building's five floors are vacant, there are not many furnishings that need to be removed except for a couple of toilets and sinks on each floor.

The Deconstruction Method

The method in which the Vogue Optical Building would be deconstructed closely follows the method employed in the Riverdale Case Study Project. Prior to commencing deconstruction, a detailed inventory of the building's materials was taken. The most important part of assessing the feasibility of deconstruction is to take a detailed inventory of how and of what the building is made. Every component, its condition, and the manner in which it is secured to the structure can have an impact on the cost-effectiveness and time involved in salvage.

I visited the building on numerous occasions to take measurements in order to draw the building plans and to record and quantify all of its components from roof to foundation. If the building were to be actually deconstructed as stated, after an inventory of the materials is taken, if there was found to be any asbestos or lead in the building, abatement procedures would be carried out. Following this, permitting would be obtained. These procedures are the same that are required for building demolition and would follow the same methods of operation.

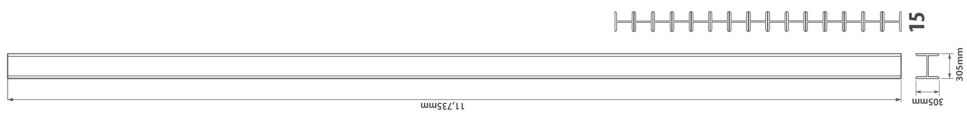

Steel Column

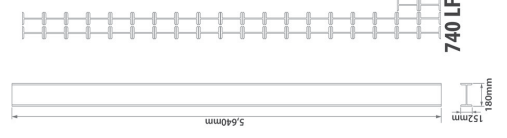

Steel Beam N-S

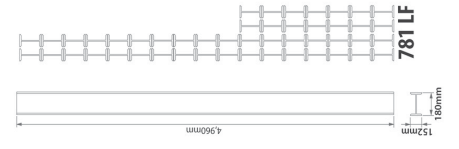

Steel Beam E-W

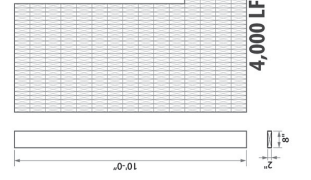

2 x 8 Wood Joists

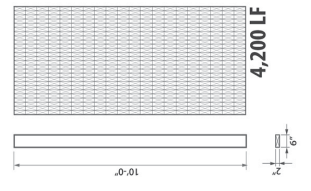

2 x 6 Wood Studs

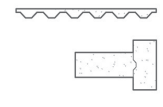

Concrete

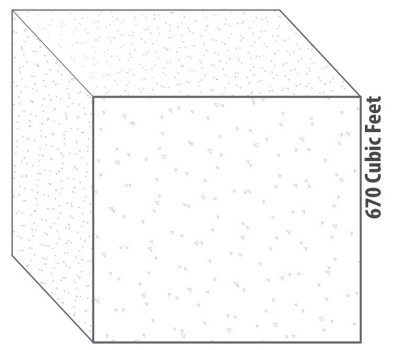

Rebar (No. 3)
@ 12" o.c.



Material inventory of the primary structure of the Vogue Optical Building

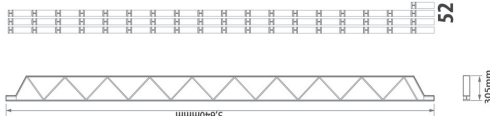

Open Web Steel Joist

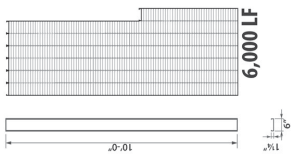

Lightweight Steel Stud

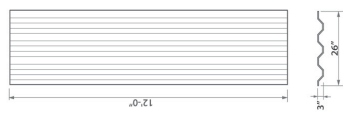

Corrugated Metal Decking

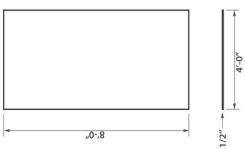

Drywall

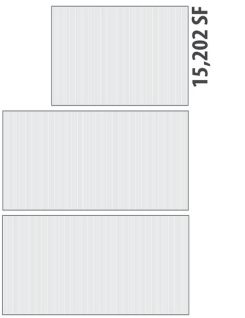

Plywood/Oriented-Strand Board (subfloor)

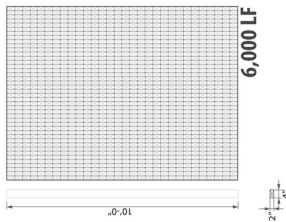

2x4 Wood Stud

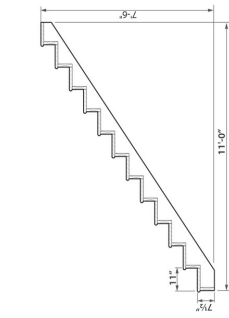

Stair Sets

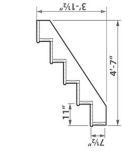

2 SETS

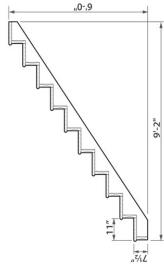

14 SETS



Material inventory of the secondary structure of the Vogue Optical Building

Interior



Ceramic Tile

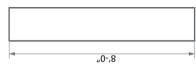

Vinyl

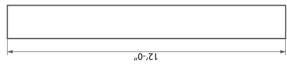

Carpet



Hardwood

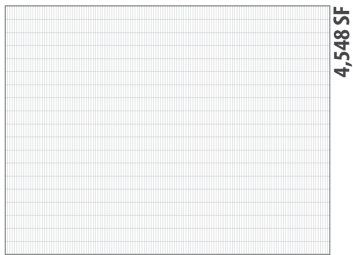

Suspended Ceiling Tile

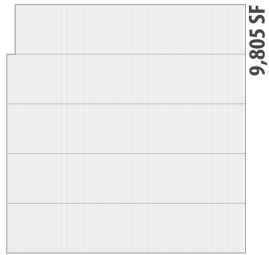

Suspended Ceiling Tile

Exterior

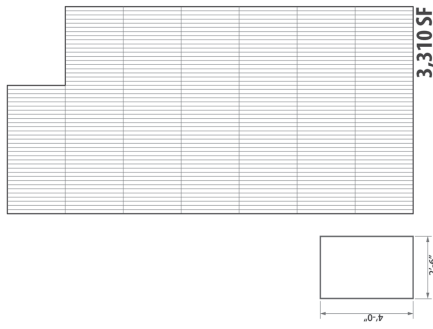

Sandstone Panel

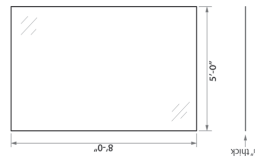

Glazing



Brick



Aluminum Siding

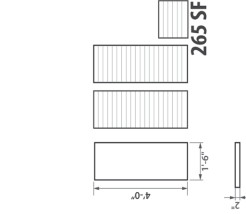

Black Marble

Exterior

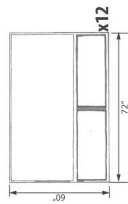

Aluminum

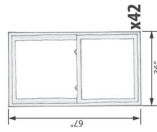

Double-Hung Wood

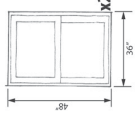

Single-Hung Wood

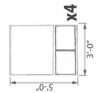

Aluminum Frame

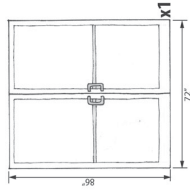

Glass Double w/ Aluminum Frame

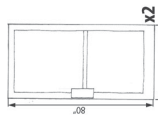

Glass w/ Aluminum Frame

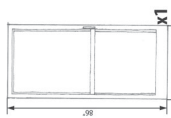

Glass w/ Aluminum Frame

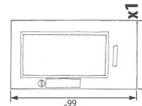

Solid Wood w/ Glass

Interior

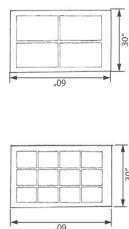

Wood Casement

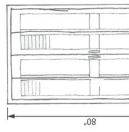

Wood Casement

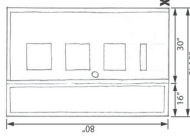

Solid Wood w/ Sidelight

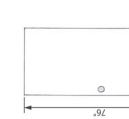

Solid Wood

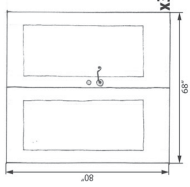

Double Wood w/ Full Glass

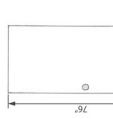

Hollow Aluminum

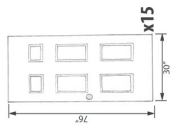

Wood Panel

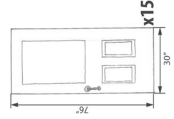

Wood Panel w/ Half-Glass

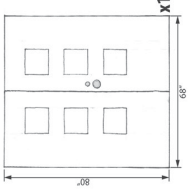

Double Solid Wood w/ Vision Glass

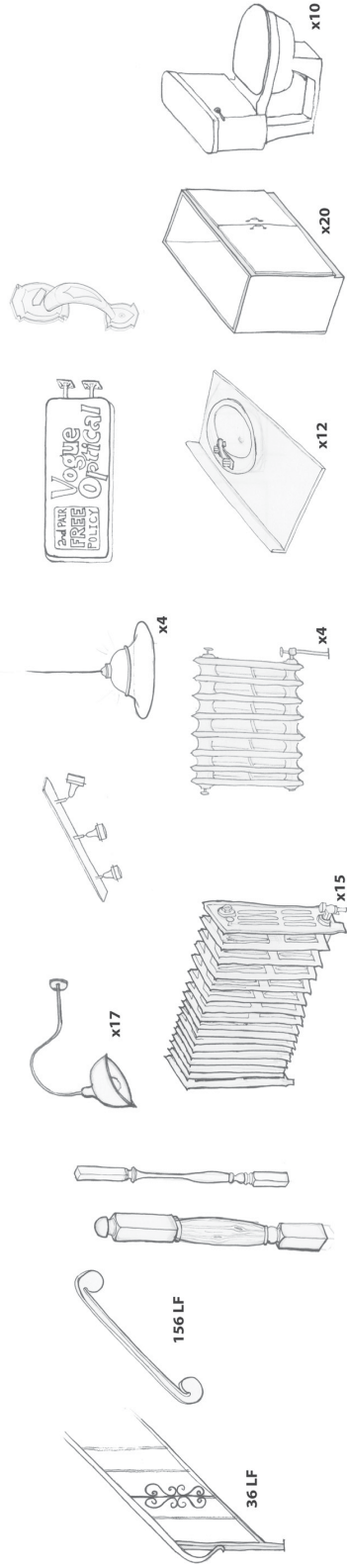

Material inventory of the doors, windows, fixtures and fit-ups of the Vogue Optical Building

Participants

The project participants would consist of a job foreman, eight to ten labourers, and someone with deconstruction experience to provide guidance. The dismantling of building components requires a lot of man-hours but not much job experience. In this way, the Vogue Optical Building deconstruction could be used as a job training project. Since deconstruction is such a rarely employed method, few construction workers have experience in it, which offers an excellent opportunity to make this project a learning experience for those interested in getting into the industry.

The Sequence of Deconstruction

The Vogue Optical Building would essentially be deconstructed in the reverse order of construction (i.e. those components installed last are removed first). In order for this process to run as smoothly and efficiently as possible the materials must be stacked into organized piles as they are taken apart. Also, a truck with a boom attachment would be positioned along Sackville Street and would be employed to lift and lower building materials down to ground level and onto another truck which would transport them to the staging area.

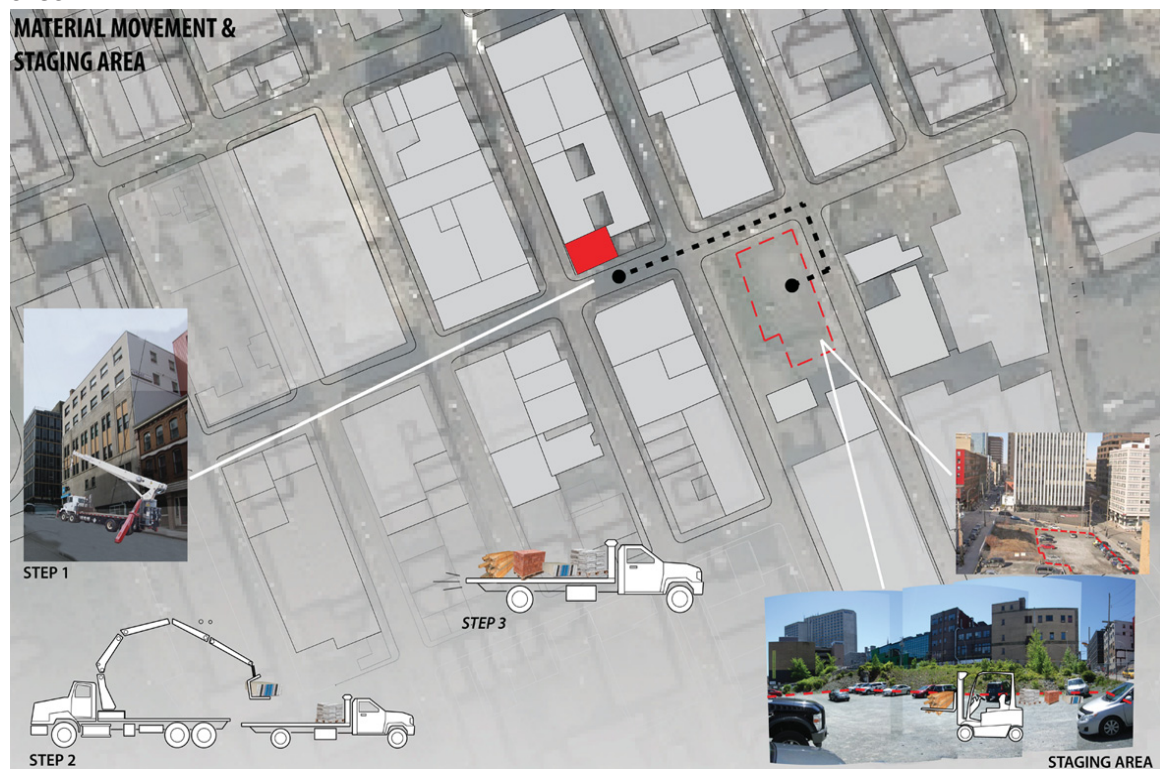

Logistics of deconstruction, location of boom truck and staging area

The Sequence of Tasks

Interior

1. Interior doors, windows, frames and trim and baseboards.
2. Appliances, suspended ceiling tiles, cast iron radiators, cabinets, plumbing fixtures and railings.
3. Floor finishes (hardwood, carpet, vinyl and ceramic tile)
4. Drywall, piping and wiring
5. Non-loadbearing partition walls

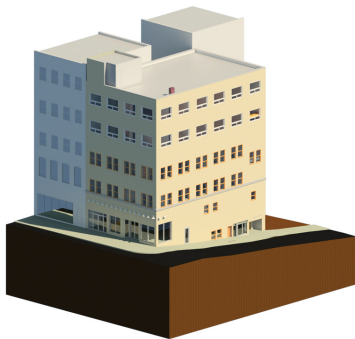

The Existing Vogue Optical Building.



Step 1.

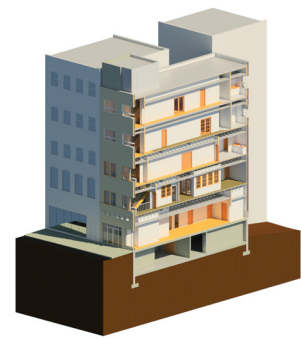

Step 2.



Step 3.



Step 4.

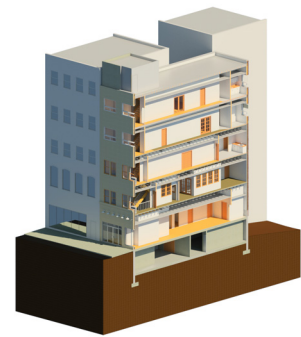

Step 5.

Exterior

6. Exterior windows, window trim, signage, exterior gooseneck lights and glazing
7. Roofing material on the sixth floor above the elevator shaft
8. Sixth floor roofing joists (structure) and aluminum siding on the sixth floor
9. Sixth floor wall masonry and wall structure
10. Elevator car and tracks
11. Roofing material
12. Roof sheathing boards
13. Roof framing joists and structure are removed. Set of stairs to roof (the stairs are removed as one unit. The risers and treads remain attached to the stringers).
14. Interior load bearing walls on the Fifth Level
15. Exterior masonry façade, concrete elevator shaft and bricks of the chimney.

(These materials would be taken apart from the top – down and depending on the size of the crew could be removed concurrently with the interior load bearing walls).

16. Fifth Level exterior walls studs
17. Fifth Level sheathing boards
18. Fifth Level floor joists and sets of stairs.
19. Fourth Level interior load-bearing walls.
20. Fourth Level exterior masonry walls, elevator shaft and chimney.
21. Fourth Level exterior wall studs.
22. Fourth Level floor decking (concrete and metal decking).
23. Fourth Level open web steel joists and stair sets
24. Third Level exterior masonry, elevator shaft and chimney (top-down)
25. Third Level perimeter steel studs
26. Third Level floor decking (concrete and metal decking)
27. Third Level open web steel joists and stair sets
28. Second Level exterior masonry walls, elevator shaft and chimney (top-down)
29. Second Level perimeter steel studs
30. Remaining facade
31. Second Level floor decking (concrete and metal decking)
32. Second Level open-web steel joists and stair sets
33. Main Level steel studs
34. Main Level concrete floor, elevator shaft and chimney
35. Remaining interior concrete



Step 6.

Step 7.

Step 8.



Step 9.



Step 10.



Step 11.



Step 12.



Step 13.



Step 14.

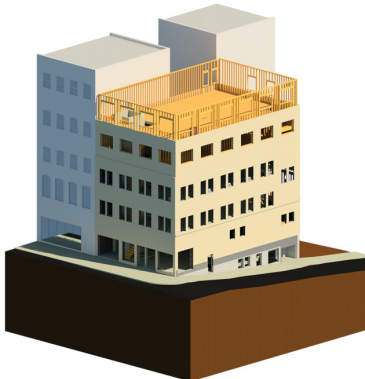

Step 15.



Step 16.



Step 17.

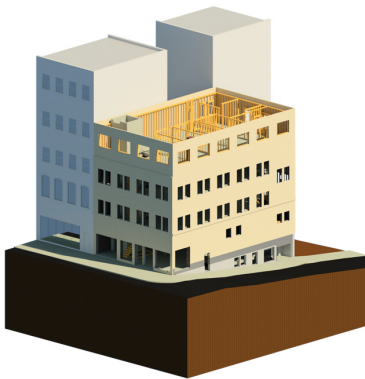

Step 18.



Step 19.

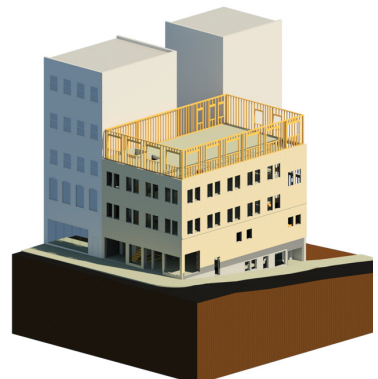

Step 20.

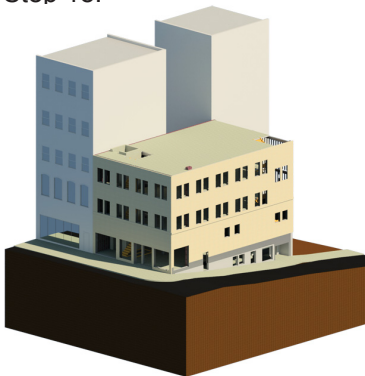

Step 21.

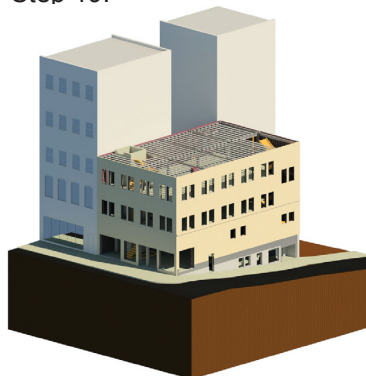

Step 22.

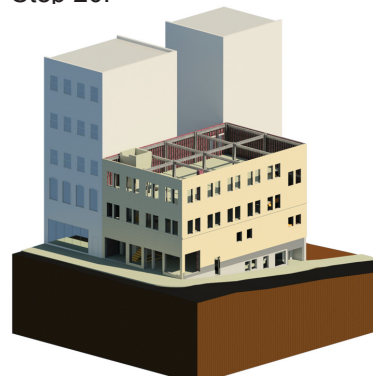

Step 23.

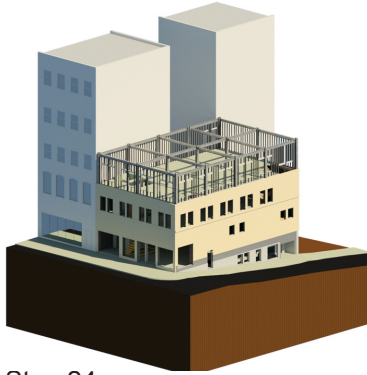

Step 24.

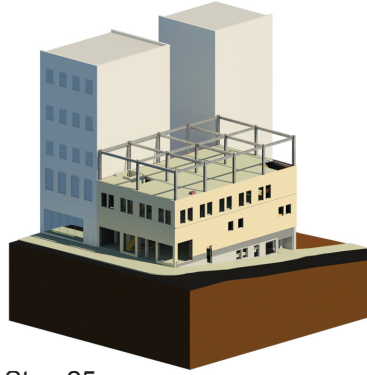

Step 25.

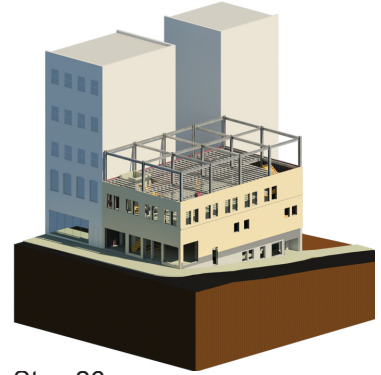

Step 26.

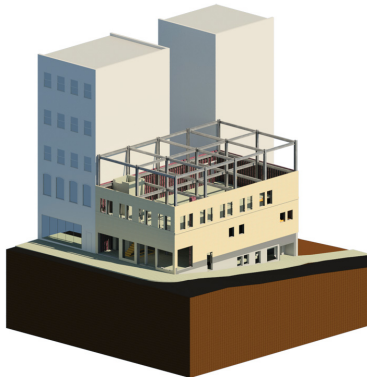

Step 27.

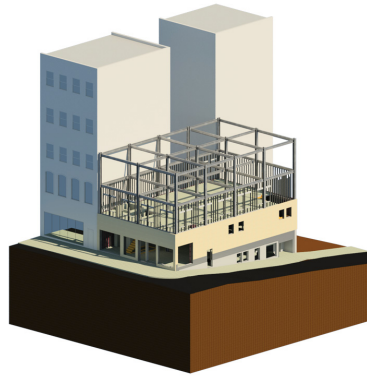

Step 28.

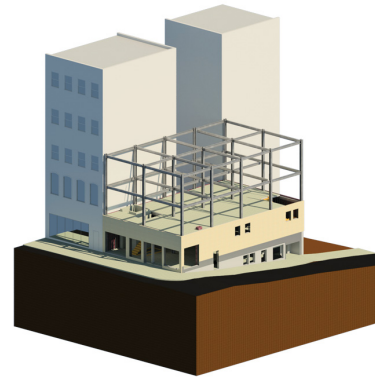

Step 29.

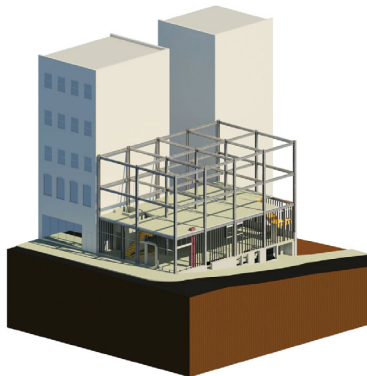

Step 30.

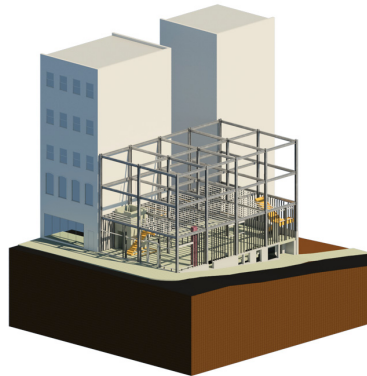

Step 31.

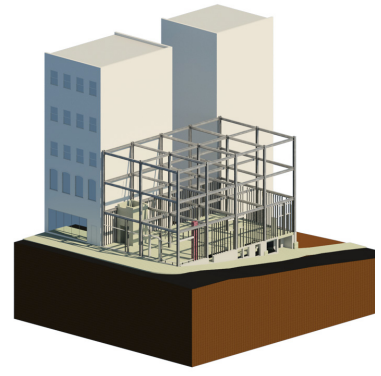

Step 32.

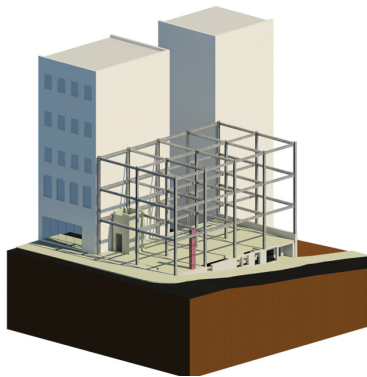

Step 33.

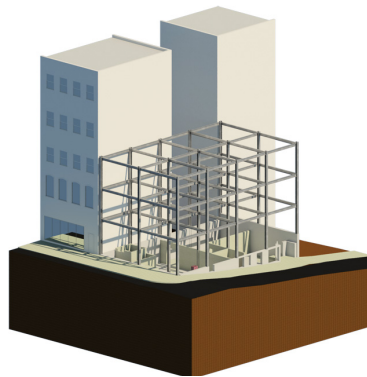

Step 34.

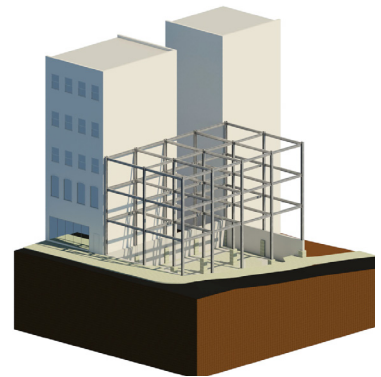

Step 35.

In conclusion with a crew of eight to ten labourers working 45 hours a week, it would take 54.5 weeks to deconstruct the Vogue Optical Building. (A detailed breakdown of the labour summary of tasks and time required per building component can be found in Tables 2 and 3 of the Appendix). The time required per task category would be as follows:

| Time Required per Task Category | | |
|----------------------------------------|---------------------------|-----------------------------------------|
| Task Category | Total Labour Hours | Percentage of Total Labour Hours |
| Disassembly | 1,270 | 26% |
| Processing | 3,231.75 | 66% |
| Production Support | 385.75 | 8% |

In summary, the majority of time was spent processing materials (66%), this includes denailing wood, cleaning mortar off brick, crushing masonry, etc. Also, the structural components required almost half of the total time to deconstruct (48.25%). In order to reduce the time spent processing, planning ahead is critical. For example, dumpsters, wheelbarrows, pallets, etc. must be easily accessible to the workers so that time is not wasted moving materials twice, (i.e. have pallets on hand to stack the drywall instead of leaving it on the ground and then having to return and stack it afterwards). Also, containers, wood denailing and brick cleaning stations should all be located in easily accessible places in order to minimize walking time.

There are more logistics involved with deconstruction, as the materials have to be sorted and processed instead of all being thrown into a dumpster (as is the case with demolition). Therefore the key to job efficiency is flexibility. The site supervisor should always be ready to move a denailing station, reassign workers or change the size of the crew to accommodate the flow of materials.

Material Selection

In order to prove this thesis' success I must attempt to reuse as many of the materials as possible. The majority of construction materials found in buildings can be recycled, however, this is not common practice mainly due to time, cost and logistical constraints. The constraints I set for this project were primarily based on two factors: the distance of the recycling facility from the site and the recyclability of the material.

Proximity

How far does a material need to be shipped in order for it to be reused again? For example, all of the masonry can be crushed in the staging area by a portable crusher which turns it into aggregate to be used for new masonry (concrete or brick).

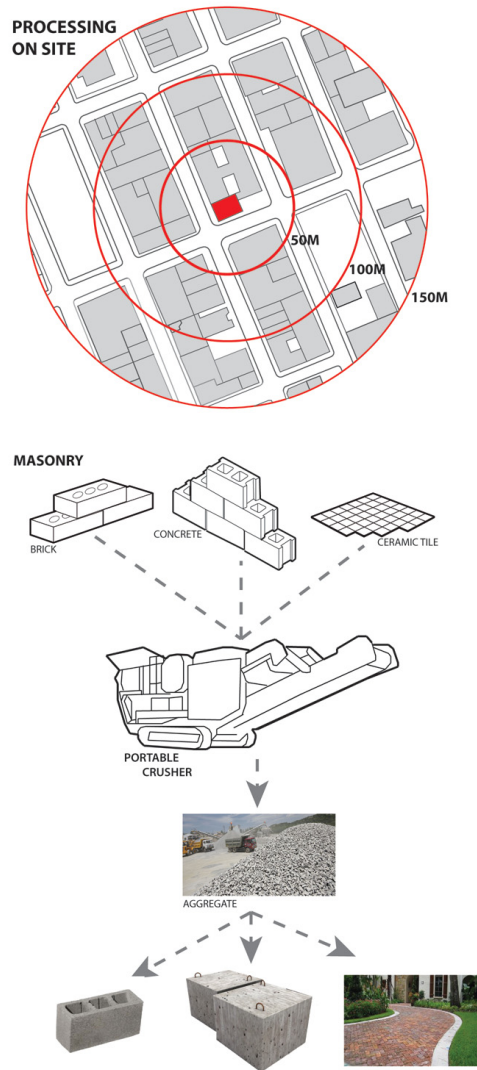

Materials to be recycled and processed at the staging area.

The remaining materials that are to be recycled will be processed within 10km of the site at either the C&D Centre or at John Ross & Sons. At these two locations the materials will either be processed and returned to site to be reused, or shipped further to various locations in the Maritimes to undergo final processing.

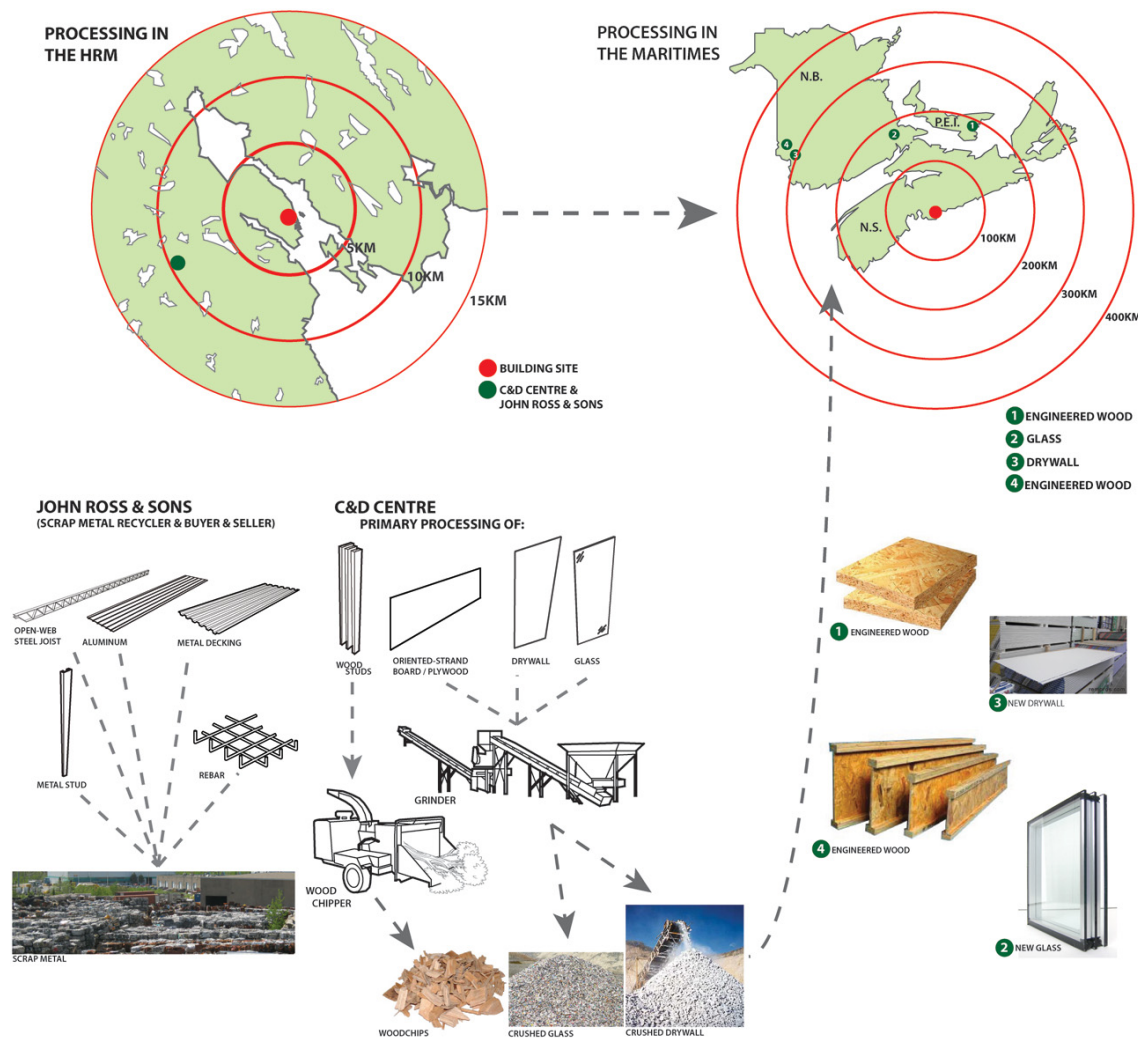

Materials to be recycled and processed in the HRM and/or the Maritimes.

Some of the materials not shown can be recycled yet currently no such facility exists in the Maritimes. For example, ceiling tiles can be crushed down and re-made into new ceiling tiles.²¹ However, the closest recycling facility to Halifax to do this, is located in southern Ontario. This was deemed too far, as the increased shipping distance would have too great of a negative impact on the embodied energy of the material. Instead, ceiling tiles will not be reused in the new design, and the existing tiles from the Vogue Optical Building will be specified to be shipped to Ontario where they can be recycled for use in projects in that area.

21 Armstrong, "Save the Ceilings," Recycling Program, (2013), <<http://www.armstrong.com/common/c2002/content/files/15976.pdf>>.

Material Recyclability

What processes are involved in order to recycle the material? How much can the embodied energy of a material be improved upon by recycling? Embodied energy is the total energy inputs consumed throughout a product's life cycle.²² This includes: the energy used for the extraction of raw materials, transportation to factory, processing and manufacturing, transportation to site, construction, maintenance, replacement and finally recycling. For example, almost all metal found in buildings is recycled. This is due to the incredible amount of energy that is required in order to mine and produce it. This is one of the main reasons why I chose to retain the steel structure of the Vogue Optical Building. Steel is 100% recyclable and can be infinitely recycled without loss of quality. For example, building and bridges made with steel last 40 to 100 years, or longer with proper maintenance.²³ One ton of recycled steel saves 642 Kwh of energy, 1.8 barrels of oil, 10.9 million Btu's of energy, and 4 cubic yards of landfill space.²⁴

22 Marion Lawson, *Material Life: Embodied Energy of Building Materials*, (Cannon Design, 2013), 1, <<http://media.cannondesign.com/uploads/files/MaterialLife-9-6.pdf>>.

23 World Steel Association, *Fact Sheet: Energy*, (Oct. 2008), 2, <<http://tinyurl.com/mv7as44>>.

24 "Buildings & Grounds Maintenance: Land Buildings & Real Estate," Frequently Asked Questions: Benefits of Recycling, (Stanford University, Feb. 25, 2011), <http://bgm.stanford.edu/pssi_faq_benefits>.

CHAPTER 4: DESIGN

Design Intentions

If you have something and you want to keep it for the future, preserve it. If you have grapes and want to keep them you might make wine, or you might dry them and make raisins. Eventually, however, raisins will dry up and blow away. Fine wine will last centuries, if properly handled.²⁵

This quote applies to the field of architecture; a building that is designed and built well can last generations. Well-designed buildings have the ability to create spaces that allow for an optimal amount of uses. The design of a building can have an incredible effect, both positive and negative, on its users. In addition to incorporating passive technologies, natural day lighting and ventilation, a building should also be designed with flexibility of uses in mind.

“Designing buildings and infrastructure so that individual materials can be easily separated can help to facilitate the recycling or reuse processes. Minimizing the time and costs needed to recover materials can often increase the chances that they will be recycled or reused instead of being sent to landfills.”²⁶ One solution to this is to simplify the construction process. Mass production or the use of prefabricated materials is a more efficient and economical method of achieving this, yet tends to create a “cookie-cutter” type of building or structure.

Therefore the newly proposed design should be flexible, adaptive and resilient to allow for the widest range of program in the future. In order for the method of deconstruction to be employed more often, its process needs to be considered at the design stage of the project. Materials must be thought of in unconventional ways in order to achieve new forms and create new spaces. Once a material has been reduced to its singular, most basic form, how can it then be manipulated and combined with other materials in order to create multipliable series of forms and patterns?

25 Richard L. Austin, comp., *Adaptive Reuse: Issues and Case Studies in Building Preservation*, Edited by David G. Woodcock, W. Cecil Steward and R. Alan Forrester, (New York: Van Nostrand Reinhold, 1988), 17.

26 Robert Crawford, *Life Cycle Assessment in the Built Environment*, (London: Spon, 2011), 29.

How do we make buildings more sustainable and adaptable to allow for changes in program in the future? A lot of modern architecture that is being designed and built today is about making a statement, but how viable will that statement be in 10, 20 or 30 years from now? The tide has already begun to turn against these statement buildings. For instance, architect Ken Shuttleworth, who was on the team at Foster and Partners that designed the Gherkin skyscraper in London, U.K. has begun speaking about how irresponsible it was to build a building completely covered with glass.

“Everything I’ve done for the last 40 years I’m rethinking now,” he says. “If you were designing [the Gherkin] today... it wouldn’t be the same product all the way around the building. We need to be much more responsible in terms of the way we shade our buildings and the way we thermally think about our buildings.”²⁷

The design of a building must take into account future change in program as well as material recyclability. A comparison can be made between a building and the human body, just as the bones, organs, heartbeat and brain function define a human being so do the structure, building systems and users define a building. Just as a human body grows and changes over time so must a building. We must outline what the ‘bones’ and heartbeat of a building are so that it has the ability to adapt with relative ease over time as different users occupy its spaces and as more sustainable technologies are invented.

27 Tom Dyckhoff, “Could the Era of Glass Skyscrapers be Over?,” *Rooms with a View*, Radio, Prod. Hannah Sander, BBC Radio 4, (London, 27 May 2014).

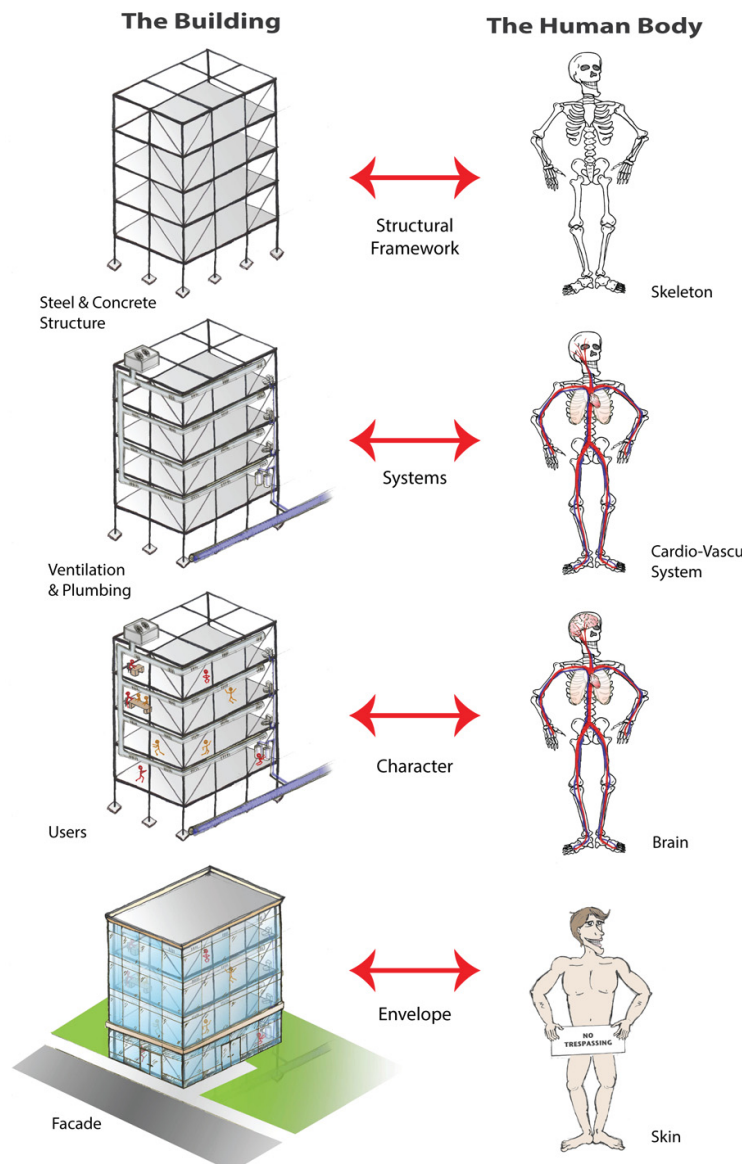

Building and body comparison.

Design Concepts

The Study of Form and Pattern

One reason why buildings are demolished is because their layout and program do not meet the needs or requirements of its users. And although we cannot foresee the future; as architects, we can design buildings that have the ability to change. Modular/pre-fab design is one solution as they allow parts to be added and/or subtracted from a building with relative ease.

The simple fact is that things evolve; and we also evolve.
 The world we know today will be a different world tomorrow.
 And I think that with this insight we can approach our work [architecture] in a relaxed way.²⁸

A famous physiologist of the late 18th century, George Cuvier made the observation about organisms: Around the living being there is a continual circulation from the outside to the inside and from the inside to the outside, constantly maintained and yet fixed within certain limits.²⁹ It is up to architects to determine what these limits are yet ensure that they do not become 'limiting.' Just as the program and functions of a building can be compared to the human body, the design of the building can be compared to a loom and textiles. "The warp and weft are the armature for the individual continuities of the threads whose interweaving opens up the dialectical foundation of the loom into a multiplicity of relationships."³⁰

The spaces that are created within the structural grid of a building can be compared to the textile dressing on a loom. Just as the structure of a building provides the basis for its design; the loom provides the basis for the textile pattern. However, once the textile is removed from the loom it can be folded, bent, stretched or cut into an endless variety of new shapes yet it always maintains the initial pattern. Buildings should be designed to develop in the same way. A building's structure provides the framework for the forms and masses that emerge through the design. The primary structure is the constant while the interior spaces of a building should be designed in a way that they are adaptable and flexible, so as a building's users change over time the program of the space can change as well.













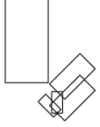
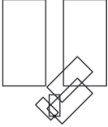





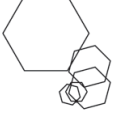
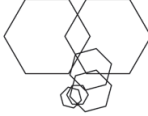

In order to further study this idea of designing a "loom" or primary framework of a building I began a series of experiments using formal and informal geometries to attempt to determine a building's primary geometric shape. Is there an universal building block shape (or geometry) that exists, and is there a way of determining it? To begin I drew a series of geometric shapes then through a series of manipulations (scale, rotate, reflect, etc.) I studied what patterns began to emerge. Ultimately, I concluded that I had taken this exer-

28 Deborah Gans and Zehra Kuz, eds., *The Organic Approach to Architecture*, (Chichester, England: Wiley-Academy, 2003), 4.

29 Ibid., 50.

30 Ibid., xiv.

cise to its limits and that working with geometric forms and patterns in a two-dimensional realm was not pertinent to my design as architecture exists in three-dimensional volumes.

| | 1. Rotate 45° | 2. Mirror along Vertical axis and Scale x2 | 3. Shift up 4 | 4. Rotate 45° and Scale x2 | 5. Mirror along Vertical axis |
|-----------|-------------------------------------------------------------------------------------|-------------------------------------------------------------------------------------|-------------------------------------------------------------------------------------|---------------------------------------------------------------------------------------|---------------------------------------------------------------------------------------|
| RECTANGLE |  |  |  |  |  |
| TRIANGLE |  |  |  |  |  |
| HEXAGON |  |  |  |  |  |
| LEAF |  |  |  |  |  |
| ORGANIC |  |  |  |  |  |

Experimenting with geometric shapes

I then proceeded to experiment with form and pattern using blocks of wood. I arranged them in multiple ways, drawing the configurations in plan and elevation. The idea for this was to determine what kind of spaces and forms would emerge when the same dimensional block was configured in different ways. The results of this study did not yield fruitful results as the dimensions of the blocks of wood did not relate to any particular building material. I concluded that I would only begin to find real results when I began experimenting with the real building materials that are found in the Vogue Optical Building.

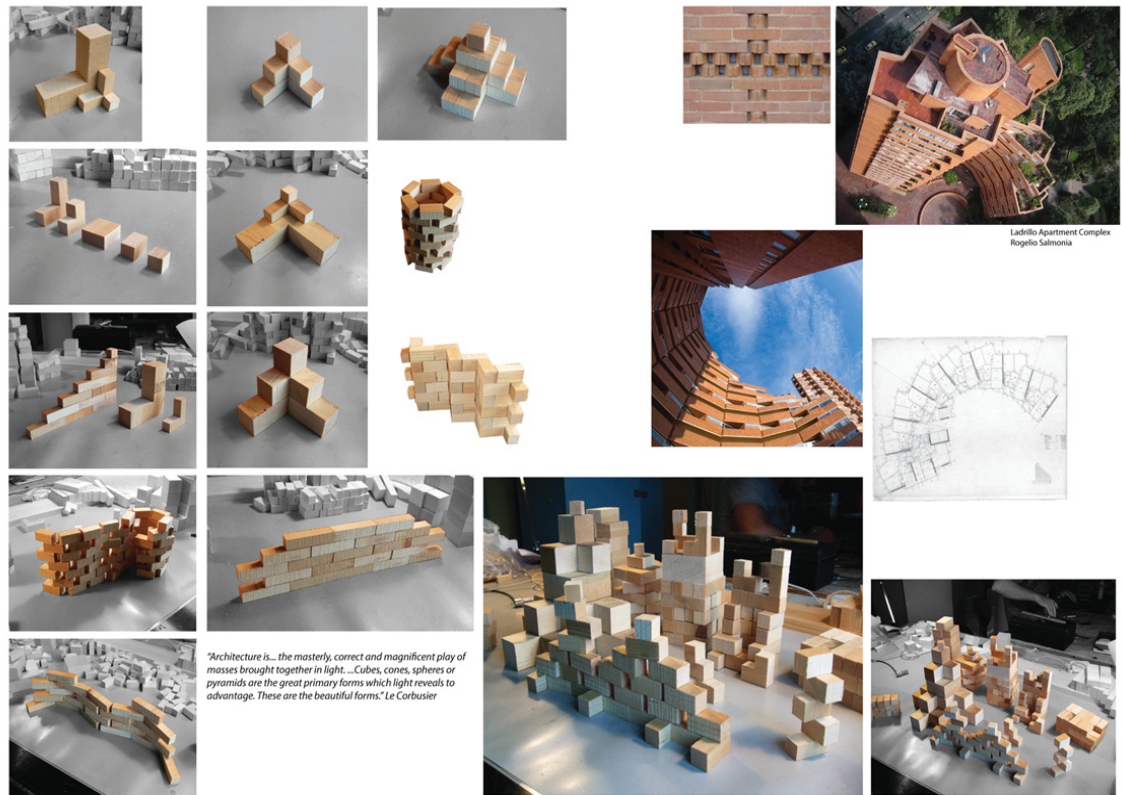

Exploring geometry using standard-sized blocks of wood

The Unconventional Design Method

According to the traditional method, the architect normally first develops a composition embracing volumes, elements and systems; the components and materials needed to meet these stipulations are then sought from a well-established market. Yet, in the case of architecture created from recycled materials, this market does not exist, and so the process is inverted: the design team must first identify the sources of materials suitable for reutilization and then start to define the details.³¹ Unlike the traditional method of design where an architect is given a site and a program, this design project began from the unconventional starting point of having a site and an inventory of materials to frame the new building.

With a detailed inventory of the materials found in the Vogue Optical Building I first began to draw all of the individual materials to scale in both plan and elevation. With

³¹ Bahamon, *Rematerial*, Introduction.

this visual I was then able to better visualize how these components could be used in new and unconventional ways. As a starting point I began sketching out various material combinations by altering the orientation of the material. For example, an open-web steel joist, which was once a member that held up the floor structure was rotated 90 degrees, arranged with other open-web steel joists and became a structural column to support the floor above.

Then, I took a set of stairs and turned them sideways and combined them with wood 2x8s to create a counter.

This exercise continued until I had an exhaustive list of unorthodox material combinations. The next phase of the project moved to a larger scale; to the design of the new building and the combination of these upcycled materials with recycled ones.

The Focal Point of the Design

After having determined the palette of recycled materials and creating a comprehensive list of upcycled materials to be used, I then moved on to designing the new building. Since I had previously decided to retain the steel structure, this became the starting point for my design sketches. I began to experiment with various ways in which I could interrupt this regular, rectangular grid while also creating a focal point for the new design. After some brainstorming I decided to interrupt the grid with a vertical atrium running from the roof down to the basement level. The atrium has multiple uses, it functions as a circulation space, brings daylight deep into the building and functions as a passive ventilation system. The atrium creates a special space within the building and in addition to its functional qualities, it combines upcycled and recycled materials in creative ways.

The atrium takes up one bay of the structural grid and is located within four steel columns. Running along the entire length of the North wall of the atrium there are a set of undulating panels which reflect light back into the building. The angles of these panels were determined by measuring the reflective angles of the Sun over the course of the year.



Model of the aluminum panels running along the north wall of the atrium.

The panels are made from upcycled aluminum siding from the Vogue Optical Building and the structural angles supporting them are made from recycled metal.

The East wall of the atrium is constructed from upcycled brick from the Vogue Optical Building. Upcycled wood framed windows break up the wall and allow users to look into the atrium from the different floors.

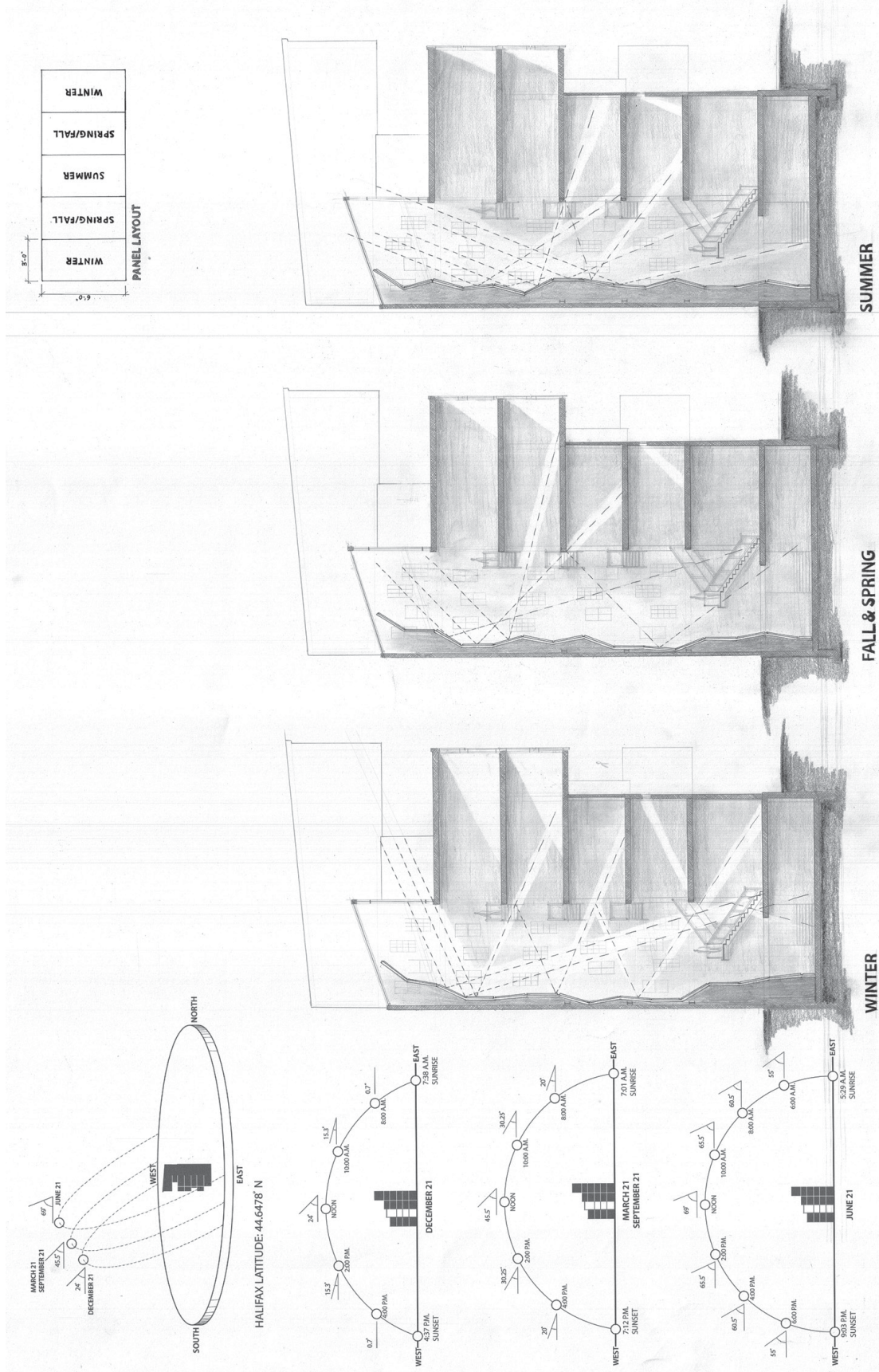

Cross section of the main atrium space, displaying how sunlight is reflected back into the building over the course of the year, data from National Research Council Canada, 2014

Building Program

“One of the most fundamental aspects of sustainable design is a focus on getting more out of the resources we use. Be it energy, water, materials, components, whole buildings or urban infrastructures, we need to get more useful service from the resources we put in. At present we have a mentality of consumerism which leads to massive use of non-renewable, primary resources, which are often extracted with great environmental damage, and create a huge amount of waste.”³²

The program of the new building will attempt to bring the focus of the thesis full circle by creating spaces where people can learn about, create, buy and sell and display their own upcycled and recycled creations. The retail and educational components will focus on materials found in residential settings instead of commercial, as it is more relatable to the public. The program of the newly designed building will be as follows:

Basement: Wood-working shop and Loading Area

The wood-working shop will contain various wood-working machines (planer, table saw, drill press, sander, jointer, hand tools, etc.). Typically the average person does not have access to these types of machines, especially for residents living downtown where space is at a premium. People can come in and be taught how to use the various machines and use them for personal projects.

Loading bay: With an exposed basement along the Sackville Street Elevation, trucks and personal vehicles will be able to pull into the building to load/ unload materials and supplies.

Main and Second Level: Retail Store

A renovator’s resource store will be located on the main and second levels where people can buy and sell various household building materials and equipment. (For example, metal radiators, windows, doors, flooring materials, etc.). Materials can be bought and worked upon directly on site.

³² Gorgolewski, *Reusing Buildings and Components*, 1.

Third and Fourth Level: Studio space, classrooms, workshops and offices

The third and fourth levels will contain large work areas where people can work on their projects. There will also be space for small classes, a small library filled with educational resources focusing on recycling, adaptive reuse and sustainability and offices for appraising services.

Fifth, Sixth and Seventh Levels: Gallery/ reception space

Exhibition and gallery space will be created in order to display people's projects as well as be rented out for exhibitions.



Perspective building section looking north, showing the interior program.

The New Building Design

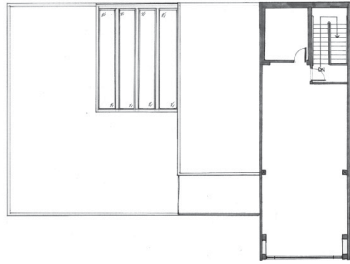

SEVENTH FLOOR

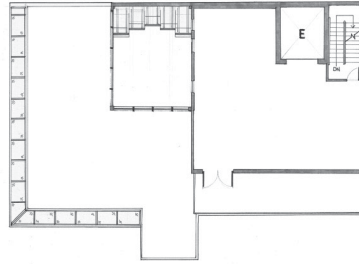

SIXTH FLOOR

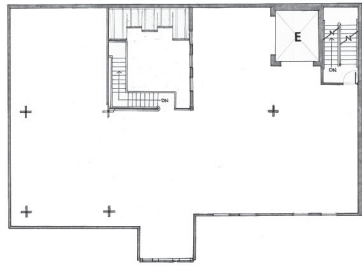

FIFTH FLOOR

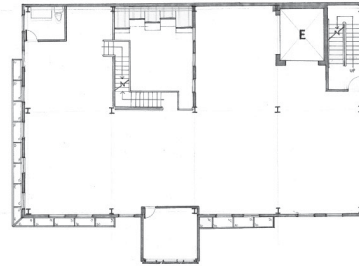

FOURTH FLOOR

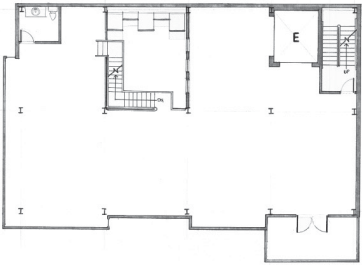

THIRD FLOOR

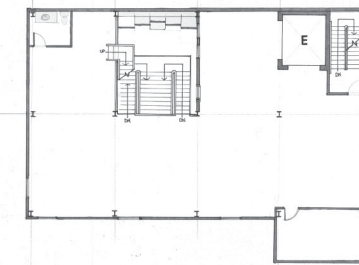

SECOND FLOOR

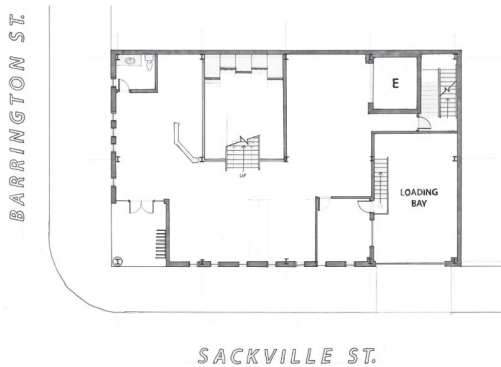

MAIN FLOOR

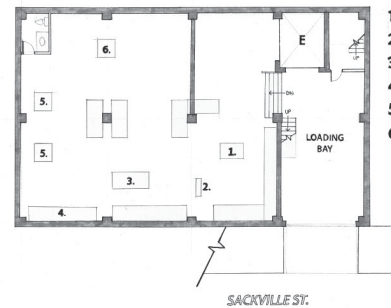

BASEMENT

- 1. PLANER
- 2. JOINTER
- 3. TABLE SAW
- 4. RADIAL ARM SAW
- 5. BAND SAW
- 6. DRILL PRESS



Floor plans of the new building design

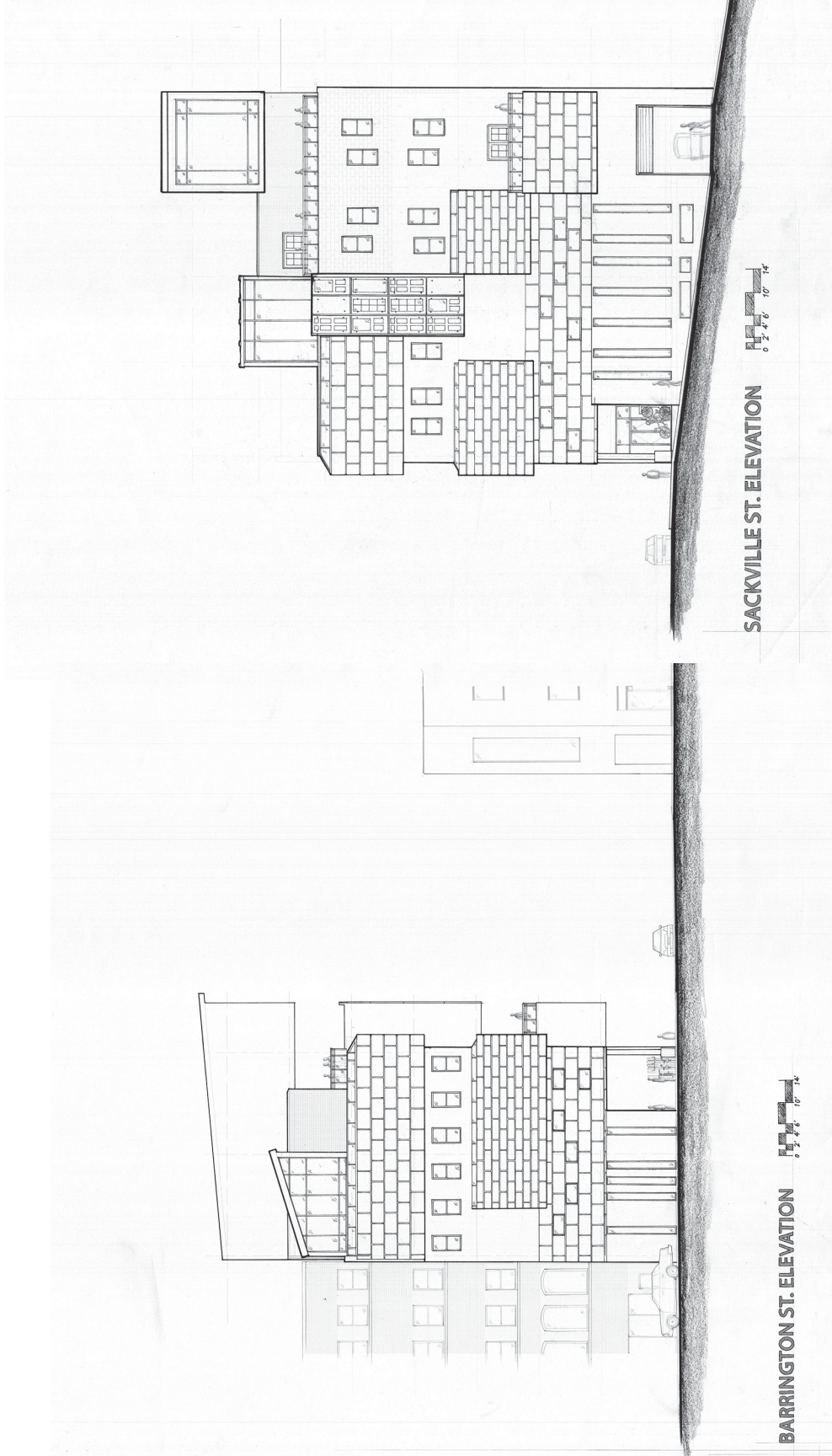

Building elevations of the new design

The remainder of the design process involved coming up with creative ways in which I could prominently display the upcycled and recycled materials that had been repurposed from the Vogue Optical Building.

On the building's exterior I did this by giving the facade a unique, eye-catching design so that it would be noticed immediately from the street. The facade juts in and out on the different levels and is composed of a wide variety of materials including upcycled sandstone panels, marble, brick and doors from the Vogue Optical Building.



View of the new design from street level.

On the top level I took advantage of the views to the harbour and cantilevered the gallery space using upcycled glulam beams made from dimensioned lumber from the Vogue Optical Building.



View of the new design looking east down Sackville Street, towards the harbour

The purpose of this thesis was to reuse, either through upcycling or recycling, as many of the materials as possible from the Vogue Optical Building. Therefore, the interior of the building will remain relatively simple. Most of the floors will be polished concrete (except where hardwood from the previous building is used), the ceilings are exposed, showing all of the mechanical systems above and any partition walls would be lightweight and moveable on tracks to allow for flexibility of space. Every effort was made to showcase the materials as is, with as little ornamentation as possible. If this building were to be deconstructed again, these efforts would be beneficial to the process as it would be easier to take apart and separate the materials and prolong their life cycle even more. As the great architect Louis Kahn said; “A great building must begin with the unmeasurable, must go through measurable means when it is designed and in the end must be unmeasurable.”³³

The following six pages contain examples of material upcycling and recycling in the new design.

33 Wilder Green, “Louis I. Kahn, Architect: Alfred Newton Richards Medical Research Building, University of Pennsylvania, Philadelphia, 1958-1960,” *The Bulletin of the Museum of Modern Art* 28, no. 1 (1961), 3.



FRONT ENTRANCE

RECYCLED MATERIALS

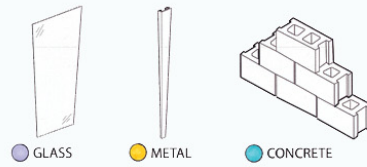
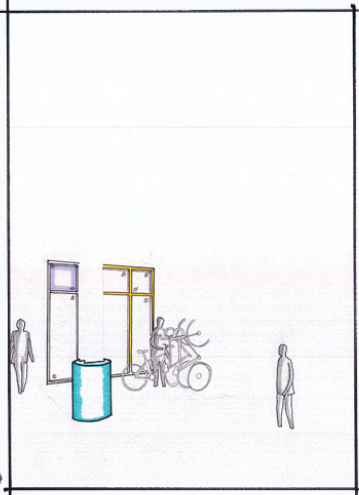

MATERIAL LOCATION IN THE VOGUE OPTICAL BUILDING

UPCYCLED MATERIALS

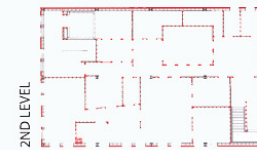
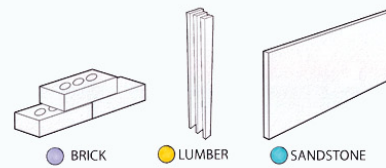
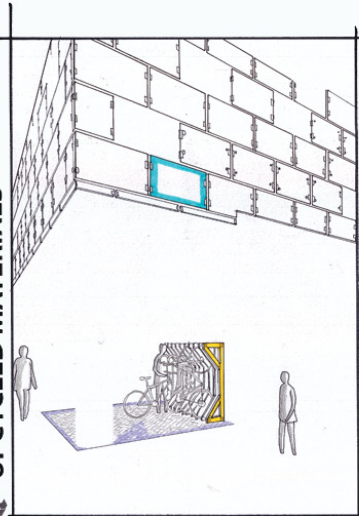

MATERIAL LOCATION IN THE VOGUE OPTICAL BUILDING

The recycled and upcycled materials found at the main entrance

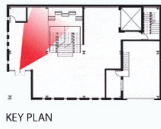

RECEPTION DESK

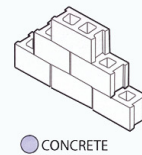
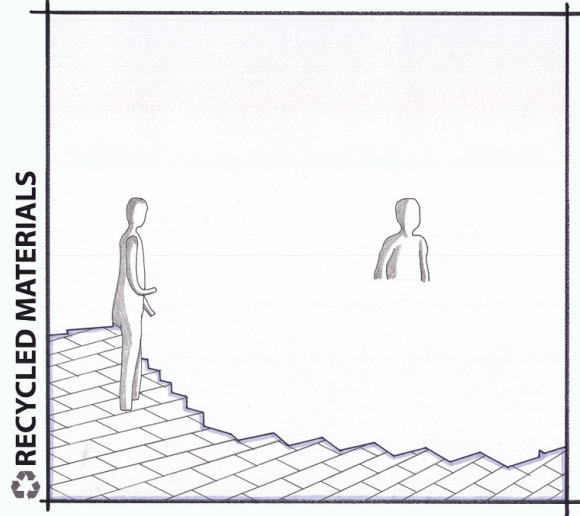

CONCRETE



MAIN FLOOR

MATERIAL LOCATION IN THE VOGUE OPTICAL BUILDING

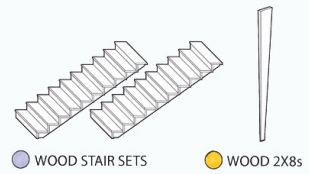
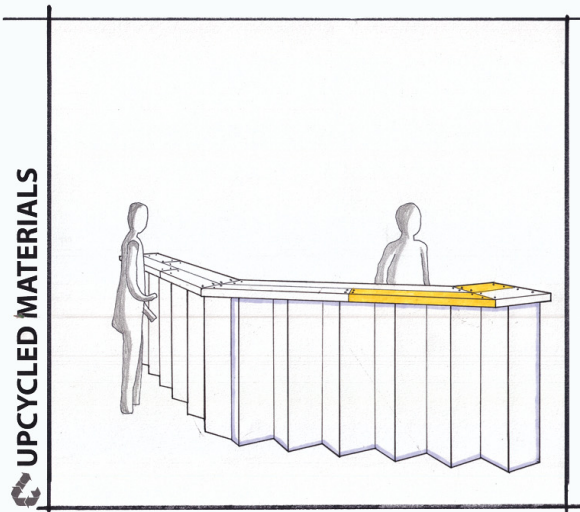

WOOD STAIR SETS

WOOD 2X8s

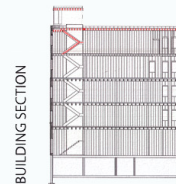

BUILDING SECTION

MATERIAL LOCATION IN THE VOGUE OPTICAL BUILDING

The recycled and upcycled materials found at the main reception area

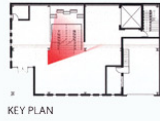

MAIN STAIRCASE

RECYCLED MATERIALS

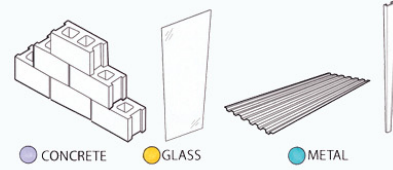
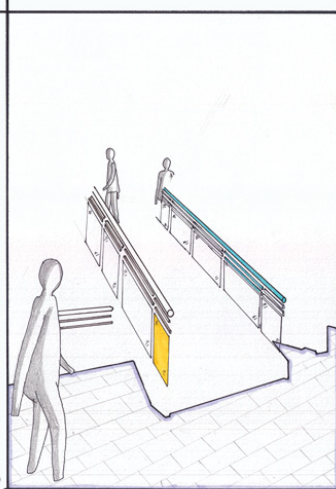

MATERIAL LOCATION IN THE VOGUE OPTICAL BUILDING

UPCYCLED MATERIALS

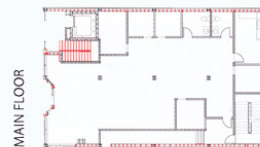
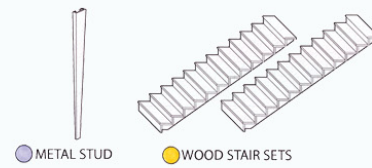

MATERIAL LOCATION IN THE VOGUE OPTICAL BUILDING

The recycled and upcycled materials found at the main staircase

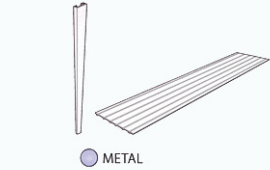
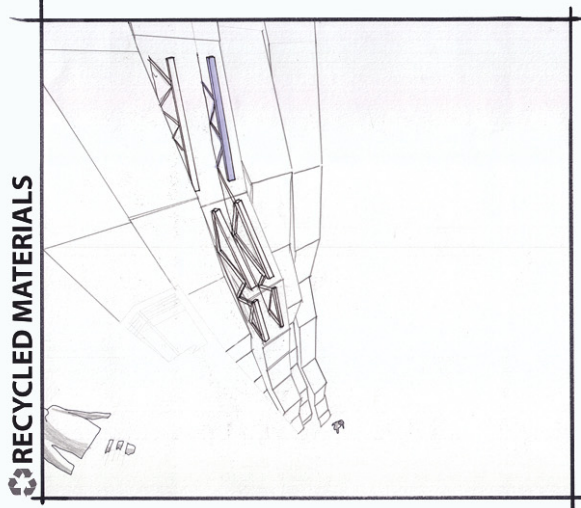
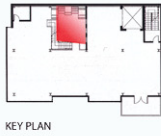

MATERIAL LOCATION IN THE VOGUE OPTICAL BUILDING

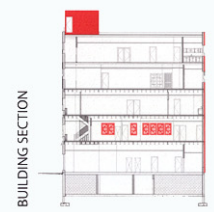
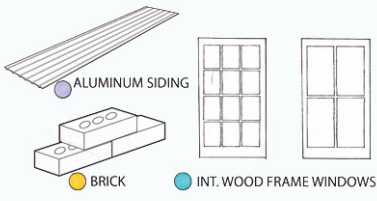
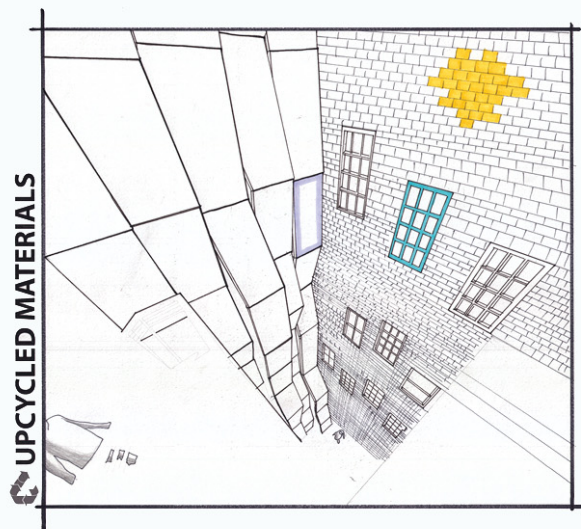

MATERIAL LOCATION IN THE VOGUE OPTICAL BUILDING

The recycled and upcycled materials found in the building's atrium

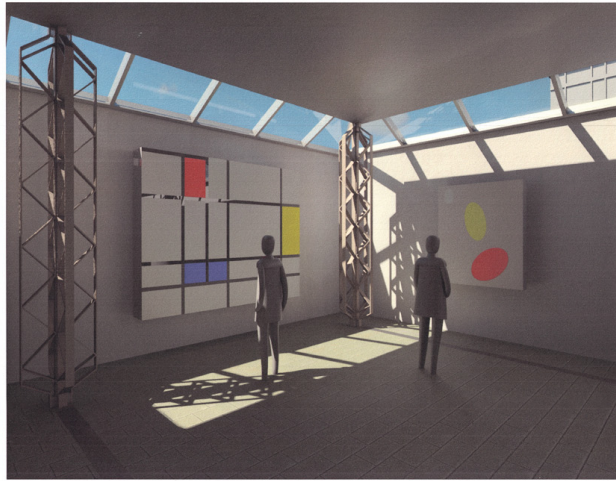

5TH LEVEL GALLERY SPACE

RECYCLED MATERIALS

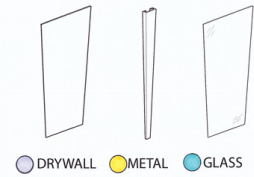
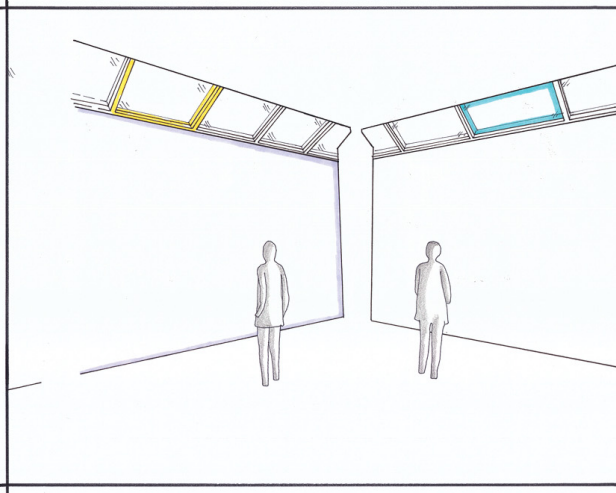

MATERIAL LOCATION IN THE VOGUE OPTICAL BUILDING

UPCYCLED MATERIALS

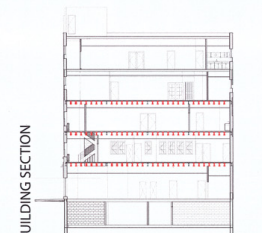
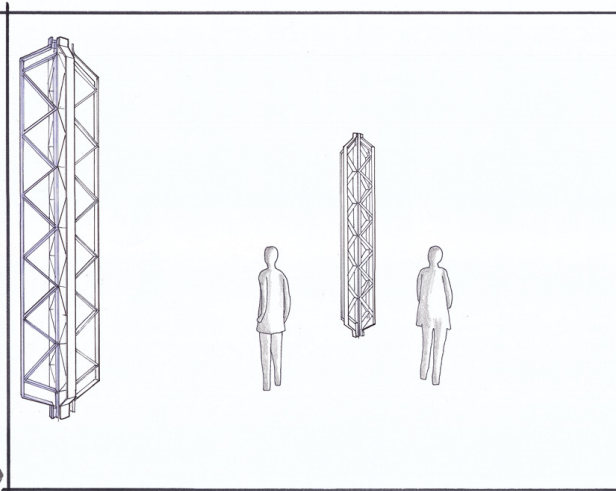

MATERIAL LOCATION IN THE VOGUE OPTICAL BUILDING

The recycled and upcycled materials found in the Fifth level gallery space

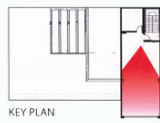

7TH LEVEL GALLERY SPACE

RECYCLED MATERIALS

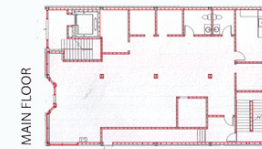
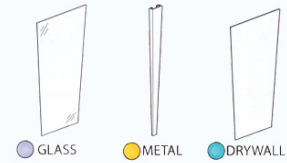
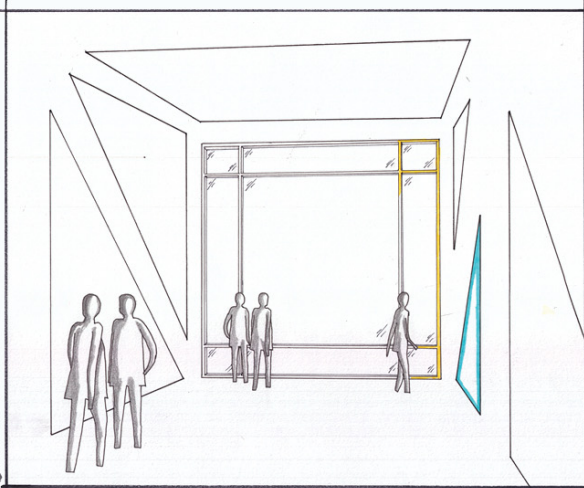

MAIN FLOOR MATERIAL LOCATION IN THE VOGUE OPTICAL BUILDING

UPCYCLED MATERIALS

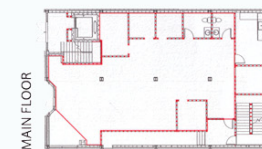
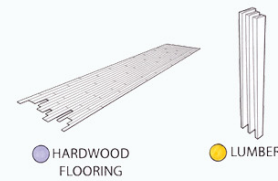
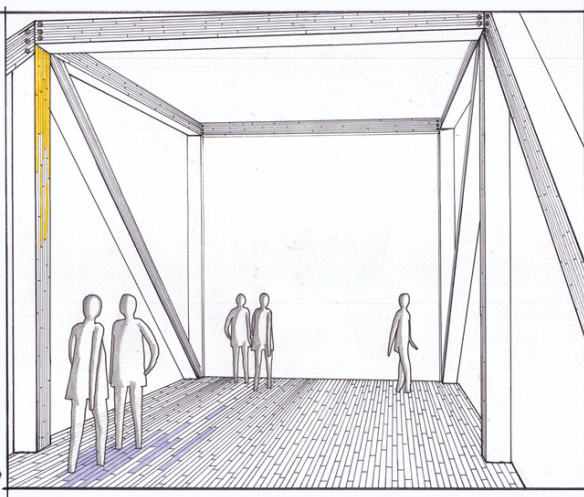

MAIN FLOOR MATERIAL LOCATION IN THE VOGUE OPTICAL BUILDING

The recycled and upcycled materials found in the Seventh level gallery space

CHAPTER 5: CONCLUSION

Some of the greatest environmental impacts of the built environment are those associated with the waste generated from the production and eventual disposal of construction materials. The production of waste from every stage of the built environment life cycle must be reduced and any waste that is produced must be carefully and appropriately managed so as not to have any long term impacts on the environment.³⁴ “We have wound up with a culture that has fashioned itself in the image of disposal instead of retention. Almost everything that we own has a useful life that ends when something breaks because the cost to repair it is a vast percentage of the cost of simply buying a newer, cutting-edge replacement.”³⁵ This applies to household products and furnishings as well as buildings and building materials. The world is slowly changing though and we can help change this disposable economy by:

- Expanding the C&D industry: making it more cost effective to repair and mend rather than dispose and replace.
- Build to Last: designing buildings with higher quality components and systems that allow them to extend their anticipated lifespan.
- Build to Dismantle: most products and buildings are built to go together but not necessarily to come apart. As designers, we could specify building components that could affordably come apart. For example, specifying that fasteners are more accessible (as well as specifying fasteners in contrast to welding or glue for components).
- Encourage the production company to dispose of their materials: Arguably the people who know a product the best are the people who designed and built it. For example Armstrong, a flooring and ceiling tile company has a program in place where they collect used flooring and ceiling tiles, recycle them and turn them into new ceiling tiles again. This lowers their costs of sourcing primary materials as well as diverting their products from landfills.³⁶

³⁴ Crawford, *Life Cycle Assessment in the Built Environment*, 28.

³⁵ Tyler Caine, “Transitioning to an Economy of Reuse,” *INTERCON*, (Dec. 7, 2010), <<http://intercongreen.com/2010/12/07/transitioning-to-an-economy-of-reuse>>.

³⁶ Armstrong, “Save the Ceilings.”

- Charge for Waste: the more it costs to throw something away, the bigger incentive for a company to turn a waste stream of their product back into a resource stream.

What better way is there to restore value into our economy? The deconstruction industry adds value to a waste stream that was formerly worth nothing, and by doing so, adds value to existing structures that people already own.

APPENDIX

Table 1. Riverdale case study³⁷

| Labour Summary of Tasks Performed | | | | | | |
|------------------------------------------|---------------|------------|---------------|-----------|-----------------------|-------------------------|
| Component | Tasks (hours) | | | | Component Total (hrs) | Labour hours/unit |
| | Disassembly | Processing | Prod. Support | Non-prod. | | |
| INTERIOR | | | | | | |
| Interior doors, frames, trim | 5.75 | 5.25 | -- | -- | 11 | 0.55/each |
| Baseboards | 4.75 | 5 | -- | -- | 9.75 | 0.19/LF |
| Kitchen cabinets | 2.75 | 0.5 | -- | -- | 3.25 | 0.27/each |
| Plumbing fixtures | 7.75 | 1.75 | -- | -- | 9.5 | 0.59/each |
| Radiators | 1.5 | 0.5 | -- | -- | 2 | 0.13/each |
| Appliances | 0.25 | 2.75 | -- | -- | 3 | 0.6/each |
| Bathroom floor tile | 2.5 | 0.5 | -- | -- | 3 | 0.038/SF |
| Oak strip flooring | 19.25 | 27 | 0.25 | -- | 46.5 | 0.038/SF |
| Plaster - upper level | 34.25 | 10 | 5.5 | -- | 49.75 | 0.012/SF (plaster area) |
| Plaster - lower level | 23.75 | 10.75 | 2 | -- | 36.5 | 0.009/SF (plaster area) |
| Piping and wiring | 6.75 | 3.25 | 0.5 | -- | 10.5 | 0.0072/lbs |
| Interior partition walls | 6.25 | 24.75 | 3 | -- | 34 | 0.18/LF |
| Windows and window trim | 10 | 2.5 | 0.5 | -- | 13 | 0.54 each |
| Ceiling joists | 1 | 4.75 | 0.5 | -- | 6.25 | 0.0075/LF |
| Interior load-bearing walls | 2.75 | 15.5 | 1.75 | -- | 20 | 0.027/LF |
| Second level sub-floor | 16 | 6 | 1.25 | -- | 23.25 | 0.023/SF |

³⁷ NAHB Research Center Inc., "Deconstruction - The Riverdale Case Study," 15.

| | | | | | | |
|-------------------------------|--------|-------|------|----|--------|-----------------------|
| Second level joists | 7.25 | 16.25 | 1.5 | -- | 25 | 0.027/LF |
| First level sub-floor | 7.75 | 8 | -- | -- | 15.75 | 0.016/SF |
| First level joists | 7 | 10 | -- | -- | 17 | 0.02/LF |
| Stairs | 2.5 | 0.75 | 0.75 | -- | 4 | 0.3/riser |
| EXTERIOR | | | | | | |
| Gutters, fascias, rakes | 2.25 | 1 | -- | -- | 3.25 | 0.014/LF |
| Chimney | 33.25 | 40.5 | 4.75 | -- | 78.5 | 0.16/cu.ft. |
| Gable ends | 8 | 3 | 0.75 | -- | 11.75 | 0.053/SF |
| Masonry walls - upper section | 14.75 | 104.5 | 20.5 | -- | 139.75 | 0.25/SF (brick area) |
| Masonry walls - lower section | 15.75 | 84 | 5.25 | -- | 105 | 0.078/SF (brick area) |
| ROOF | | | | | | |
| Roofing material | 17.75 | 18.25 | 1.75 | -- | 37.75 | 2.68/100SF |
| Roof sheathing boards | 21.25 | 14.5 | 1.5 | -- | 37.25 | 0.028/SF |
| Roof framing | 7.25 | 9.75 | 7 | -- | 24 | 0.021/LF |
| Shed roof framing at entry | 1.25 | 2.25 | -- | -- | 3.5 | 0.036/LF |
| BUILDING SUBTOTAL | 291.25 | 433.5 | 59 | -- | 783.75 | |

| | | | | | | |
|------------------------------------------------------------------|--------|-------|-------|--------|---------|-----|
| Talk shop | -- | -- | 29 | 29.5 | 58.5 | N/A |
| Supervision | -- | -- | 9.5 | -- | 9.5 | |
| Meetings, paper work, daily, roll-out and roll-in of tools, etc. | -- | -- | 38 | 43.5 | 81.5 | |
| Research monitoring | -- | -- | -- | 89.5 | 89.5 | |
| Lunch, breaks, idle | -- | -- | -- | 118.75 | 118.75 | |
| BUSINESS SUBTOTAL | -- | -- | 76.5 | 280.25 | 357.75 | |
| GRAND TOTAL | 291.25 | 433.5 | 135.5 | 280.25 | 1,141.5 | |

Table 2: Labour Summary of Tasks and Time of Deconstruction of the Vogue Optical Building

| Labour Summary of Tasks Performed | | | | | | | |
|---------------------------------------------------|---------------|------------|---------------|-----------|-----------------|--------|-------------------|
| Component | Tasks (hours) | | | | Component Total | | Labour hours/unit |
| | Disassembly | Processing | Prod. Support | Non-prod. | Hours | Amount | |
| Interior doors, frames, trim. Interior windows | 21 | 20.75 | -- | | 41.75 | 76 | 0.55 each |
| Kitchen cabinets | 5 | 1.75 | -- | | 6.75 | 25 | 0.27 each |
| Plumbing fixtures | 12 | 2.75 | -- | | 14.75 | 25 | 0.59 each |
| Radiators | 1.5 | 0.5 | -- | | 2 | 15 | 0.13 each |
| Appliances | 0.25 | 2.25 | -- | | 2.5 | 4 | 0.6 each |
| Railings | 28.75 | 9.75 | -- | | 38.5 | 192 | 0.2 LF |
| Suspended ceiling tile | 18.75 | 30.25 | -- | | 49 | 9,805 | 0.005 SF |
| Ceramic floor tile | 9 | 3 | -- | | 12 | 317 | 0.038 SF |
| Oak strip flooring | 70.75 | 100.25 | 1.75 | | 172.75 | 4,548 | 0.038 SF |

| | | | | | | | |
|--------------------------------------------|-------|--------|-------|--|--------|--------|----------------------|
| Carpet | 8 | 13 | -- | | 21 | 4,222 | 0.005 SF |
| Vinyl | 2.25 | 3.75 | -- | | 6 | 1,192 | 0.005 SF |
| Drywall | 112 | 35.5 | 4.5 | | 152 | 15,202 | SF (dry-wall area) |
| Piping and wiring | 49 | 23.5 | 6.25 | | 78.75 | 10,935 | 0.0072 lbs |
| Interior partition walls (2x4s) | 168.5 | 683.25 | 84.25 | | 936 | 5,200 | 0.18 LF |
| Glazing (storefront) | 3 | 1.5 | 3 | | 7.5 | 14 | 0.54 each |
| Windows, window trim, doors, and door trim | 26.75 | 6.5 | 1.25 | | 34.5 | 64 | 0.54 each |
| Aluminum siding | 14.75 | 4.5 | 0.75 | | 20 | 2,000 | 0.01 SF |
| Roofing material | 32.75 | 33.5 | 3.5 | | 69.75 | 2,600 | 2.68 /100SF |
| Roof sheathing boards | 41.5 | 28.25 | 3 | | 72.5 | 2,600 | 0.028 SF |
| Subfloor (OSB/ Plywood) | 77 | 24.75 | 2.5 | | 104.25 | 5,210 | 0.02 SF |
| Floor joists (wood 2x8s) | 15 | 27.25 | 1.75 | | 44 | 2,000 | 0.022 LF |
| Interior load bearing walls | 3 | 16 | 2.5 | | 21.5 | 800 | 0.027 LF |
| Lightweight steel studs | 96 | 444 | 60 | | 600 | 6,000 | 0.1 LF |
| Stairs | 36.5 | 12.25 | 12.25 | | 61 | 203 | 0.3 / riser |
| 2x6 Wood wall studs | 14.75 | 78.5 | 11.5 | | 104.75 | 3,880 | 0.027 LF |
| Open-web steel joists | 65 | 120 | 11.5 | | 196.5 | 936 | 0.21 LF |
| Chimney | 82.25 | 102 | 11.75 | | 196 | 1,225 | 0.16 SF (brick area) |

| | | | | | | | |
|-----------------------------------------------------------------|--------------|-----------------|---------------|--------------|----------------|---------|-----------------------|
| Masonry walls (brick) | 173 | 951 | 111 | | 1,235 | 7,530 | 0.164 SF (brick area) |
| Masonry facade (sandstone, marble) | 82 | 451.5 | 52.75 | | 586.25 | 3,574.5 | 0.164 SF |
| BUILDING SUBTOTAL | 1,270 | 3,231.75 | 385.75 | | 4,887.5 | | |
| Talk shop | -- | -- | 219 | 219.75 | 438.75 | N/A | N/A |
| Supervision | -- | -- | 71.25 | -- | 71.25 | N/A | N/A |
| Meetings, paper work, daily roll-out and roll-in of tools, etc. | -- | -- | 285.5 | 325.75 | 611.25 | N/A | N/A |
| Research monitoring | -- | -- | -- | 671.25 | 671.25 | N/A | N/A |
| Lunch, breaks, idle | -- | -- | -- | 890.5 | 890.5 | N/A | N/A |
| BUSINESS SUBTOTAL | -- | -- | 575.75 | 2,107 | 2,683 | | |

| | Tasks (hours) | | | | Component Total |
|--------------------|---------------|-----------------|---------------|--------------|-----------------|
| | Disassembly | Processing | Prod. Support | Non-prod. | Hours |
| GRAND TOTAL | 1,270 | 3,231.75 | 961.5 | 2.107 | 7,570.5 |

Table 3. Time Required per Building Component (as percentage of total)

| | Building Component | Total Hours | Percent of Total Labour Hours |
|-------------------|--------------------------------------------------|--------------------|--------------------------------------|
| Structural | Wood framing, sheathing | 1,283.25 | 26.25% |
| | Metal framing | 796.5 | 16% |
| | Masonry (chimney) | 196 | 4% |
| | Stairs | 61 | 1% |
| | Roofing material | 69.75 | 1% |
| | TOTAL | 2,406.5 | 48.25% |
| Finishes | Flooring (carpet, vinyl, ceramic tile, hardwood) | 212 | 4% |
| | Ceiling tile | 49 | 1% |
| | Doors, door frames, windows, window frames | 84 | 2% |
| | Drywall | 152 | 3% |
| | TOTAL | 497 | 10% |
| Exterior | Masonry (sandstone, marble, brick) | 1,821 | 37.25% |
| | Aluminum siding | 20 | .50% |
| | TOTAL | 1,841 | 37.75% |
| Other | Radiators, appliances, cabinets | 11 | 0.22% |
| | Piping, wiring, plumbing | 93.5 | 0.20% |
| | Railings | 38.5 | 0.75% |
| | TOTAL | 143 | 1.17% |

BIBLIOGRAPHY

- Armstrong. "Save the Ceilings." Recycling Program. 2013. <<http://www.armstrong.com/common/c2002/content/files/15976.pdf>>.
- Austin, Richard L., comp. *Adaptive Reuse: Issues and Case Studies in Building Preservation*. Edited by David G. Woodcock, W. Cecil Steward and R. Alan Forrester. New York: Van Nostrand Reinhold, 1988.
- Bahamón, Alejandro, and Maria Camila Sanjinés. *Rematerial: From Waste to Architecture*. New York: W.W. Norton, 2010.
- "Barrington Street Heritage Conservation District Revitalization Plan." Halifax: Halifax Regional Municipality, 2009. <<http://tinyurl.com/ltzt8jm>>.
- Bousquet, Tim. "The Chronicle-Herald Building Is Being Destroyed." Reality Bites. *The Coast*. March 2, 2010. <<http://www.thecoast.ca/RealityBites/archives/2010/03/02/the-chronicle-herald-building-is-being-destroyed>>.
- Brown, David E., Mindy Fox, and Mary Rickel Pelletier, eds. *Sustainable Architecture White Papers*. New York, NY: Earth Pledge Foundation, 2000.
- "Buildings & Grounds Maintenance: Land Buildings & Real Estate." Frequently Asked Questions: Benefits of Recycling. *Stanford University*. Feb. 25, 2011. <http://bgm.stanford.edu/pssi_faq_benefits>.
- Caine, Tyler. "Transitioning to an Economy of Reuse." *INTERCON*. Dec. 7, 2010. <<http://intercongreen.com/2010/12/07/transitioning-to-an-economy-of-reuse>>.
- Canada. National Resource Council Canada. *Sunrise/sunset calculator*. 10 Jan., 2014. <<http://www.nrc-cnrc.gc.ca/eng/services/sunrise/advanced.html>>
- Corson, Jennifer. *The Resourceful Renovator: A Gallery of Ideas for Reusing Building Materials*. White River Junction, VT: Chelsea Green Pub., 2000.
- Crawford, Robert H. *Life Cycle Assessment in the Built Environment*. London: Spon, 2011.
- "Designing for Deconstruction and Flexibility Case Study: Olympic and Paralympic Games Village, Stratford". Banbury, England: WRAP, 2012. <www.wrap.org.uk/construction>.
- Dyckhoff, Tom. "Could the Era of Glass Skyscrapers be Over?" *Rooms with a View*. Radio. Prod. Hannah Sander. BBC Radio 4. London, 27 May 2014.
- Gans, Deborah, and Zehra Kuz, eds. *The Organic Approach to Architecture*. Chichester, England: Wiley-Academy, 2003.
- Gorgolewski, Mark. "Reusing Buildings and Components." *Ontario Architects Association* (2009). <www.oaa.on.ca>.

- Green, Wilder. "Louis I. Kahn, Architect: Alfred Newton Richards Medical Research Building, University of Pennsylvania, Philadelphia, 1958-1960." *The Bulletin of the Museum of Modern Art* 28, no. 1 (1961): 3-23.
- HRM GIS Database. [ESRI File Geodatabase]. Halifax, NS: Halifax Regional Municipality, 2012.
- "International Charter for the Conservation and Restoration of Monuments and Sites (The Venice Charter 1964)." *International Council of Monuments and Sites*. (1965). <http://www.international.icomos.org/charters/venice_e.pdf>.
- Jeffrey, Colin. "Construction and Demolition Waste Recycling." Dalhousie University's Office of Sustainability. *Resource and Recovery Fund Board of Nova Scotia*. (2011): 1-35. <<http://tinyurl.com/q7tf4an>>.
- Lawson, Marion. *Material Life: Embodied Energy of Building Materials*. Cannon Design. 2013. <<http://media.cannondesign.com/uploads/files/MaterialLife-9-6.pdf>>.
- "Live in an Olympic Superstar's Apartment: London's East Village Opens." *Buildington Blog*. Dec. 6, 2013. <<http://www.buildington.co.uk/>>.
- NAHB Research Center Inc. "Deconstruction - Building Disassembly and Material Salvage: The Riverdale Case Study." Upper Marlboro, Maryland: *US Environmental Protection Agency: The Urban and Economic Development Division*, 1997.
- New Zealand Demolition and Asbestos Association (NZDAA). "Demolition - Best Practice Guidelines for Demolition in New Zealand." *WorkSafe New Zealand*. Wellington: WorkSafe New Zealand Board, 2011. <<http://tinyurl.com/l66peq8>>.
- Oxford Dictionaries*. Oxford: Oxford University Press, 2014. <www.oxforddictionaries.com>.
- Parks Canada. Federal Heritage Buildings Review Office. *FHBRO Code of Practice*. Herb Stovel. Ottawa: Parks Canada, Federal Heritage Building Review Office, 1996.
- Public Archives of Nova Scotia. *Halifax View Planes*. Microfilm. 1973. Reel V6/ 240-1973. 1-10.
- Richards, Jonathan. *Facadism*. London: Routledge, 1994.
- Roodman, David Malin, and Nicholas Lenssen. *A Building Revolution: How Ecology and Health Concerns Are Transforming Construction*. ed. Jane A. Peterson. Washington, DC: Worldwatch Institute, 1995.
- U.S. Environmental Protection Agency. "Buildings and Their Impact on the Environment: A Statistical Summary." *Green Building*. April 22, 2009. <<http://www.epa.gov/greenbuilding/pubs/gbstats.pdf>>.

U.S. Environmental Protection Agency. "Construction and Demolition (C&D) Debris." April 22, 2014. <<http://www.epa.gov/region1/solidwaste/cnd/>>.

World Steel Association. *Fact Sheet: Energy*. Oct. 2008. <<http://tinyurl.com/mv7as44>>.